



**EUROTHERM
DRIVES**

582/583/5831

Product Manual

© Copyright Eurotherm Drives Limited 2000

All rights strictly reserved. No part of this document may be stored in a retrieval system, or transmitted in any form or by any means to persons not employed by a Eurotherm group company without written permission from Eurotherm Drives Ltd.

Although every effort has been taken to ensure the accuracy of this document it may be necessary, without notice, to make amendments or correct omissions. Eurotherm Drives cannot accept responsibility for damage, injury, or expenses resulting therefrom.

Chapter 1 General Description

The Eurotherm Drives Inverters described in this manual are suitable for the speed control of standard 3-phase induction motors.

The Inverters use advanced microprocessor based technology to generate a variable frequency variable voltage output, the control algorithm combining unique space Vector Pulse Width Modulation control strategy with quiet pattern operation. The Inverters' control terminals are galvanically isolated from power circuits to allow easy system interconnection. The controller is protected against both phase to phase and phase to earth short circuits, overloads, and excessive voltages via an intelligent monitoring strategy, thus avoiding nuisance tripping and giving trouble free operation.

The Inverters require either a single phase 2 wire supply of 220/240 Volts, 50/60Hz or a 3-phase 3 wire supply, at 220/240V, 50/60Hz.

The 582 is available in two versions:

- i) 0.37/0.55kW single phase supply only
- ii) 0.55/0.75kW single or 3-phase supply possible

The 583 is available in two versions:

- i) 1.1/1.5kW single or 3-phase supply
- ii) 1.5/2.2kW single or 3-phase supply

The 5831 is available in two versions:

- i) 0.37/0.55/0.75kW single or 3-phase supply
- ii) 1.1/1.5kW single or 3-phase supply

All versions feature power derating by simple switch selection. Note that all controllers are shipped with the switches set to the lower rating.

The Inverters' output frequency ranges from 0 - 100/120Hz with varying voltage/frequency characteristics suitable for either constant torque applications or efficient operation of fans and centrifugal pumps.

The 582/583 Inverters are available in either IP00 or IP20 enclosures. The IP20 version can be supplied with the basic operator controls of speed demand, direction and start/stop, requiring only the power connections to be made to give a working system.

The 5831 is the IP54 version of the Inverter family. It can be supplied as a simple enclosed version or with basic operator controls.

An option card is also available which can be fitted in the inverter to allow use of a current reference instead of the standard voltage reference.

The inverters are fully compliant with the requirements of the EMC directive. As standard they meet the industrial immunity requirements of the draft generic standard prEN50082-2 (1992), and with the addition of filters, and correct installation meet the 'residential, commercial and light industrial' emission requirements of the generic standard EN50081-1 (1992).

WARNING

Dangerous voltages remain present in the drive for a few minutes after power is removed, as indicated by the link charge LED. Allow 5 minutes after the power is removed for the link capacitors to discharge before working on the drive or ancillary equipment.

***** DO NOT CONNECT TO 415V SUPPLY. USE ONLY 220/240V *****

WARRANTY

Eurotherm Drives warrants the goods against defects in design, materials and workmanship for the period of 12 months from the date of delivery on the terms detailed in Eurotherm Drives Standard Conditions of Sale IA058393C.

Eurotherm Drives reserves the right to change the content and product specification without notice.

© COPYRIGHT in this document is reserved to Eurotherm Drives Ltd.

INTENDED USERS

This manual is to be made available to all persons who are required to configure, install or service the equipment described herein or any other associated operation.



WARNING

This equipment contains hazardous voltages and hazardous rotating mechanical components. Loss of life, severe personal injury or property damage can result if instructions contained in this manual are not followed.

Only qualified personnel should work on this equipment, and only after becoming familiar with all safety instructions regarding installation, operation and maintenance procedures contained in this manual. The successful and safe operation of this equipment is dependent on proper handling, installation, operation and maintenance of the equipment.

Contents

Chapter 1 General Description	1-1
Chapter 2 Technical Details	2-1
ELECTRICAL SPECIFICATIONS.....	2-1
ENVIRONMENTAL	2-2
MECHANICAL	2-2
Chapter 3 Outline Drawings	3-1
Chapter 4 Product Code	4-1
Chapter 5 Terminal Descriptions	5-1
TERMINAL DESCRIPTIONS 582/583.....	5-1
TERMINAL DESCRIPTIONS 5831	5-2
POWER TERMINALS	5-3
CUSTOMER ADJUSTMENTS	5-4
OPTION SWITCHES.....	5-5
Chapter 6 Diagnostics	6-1
582/583 BLOCK DIAGRAM HH057838	
5831 BLOCK DIAGRAM HH385004	
582 BASIC CONNECTION WITH BRAKE UNIT HJ057820	
583 BASIC CONNECTION WITH BRAKE UNIT HJ058055	
5831 BASIC CONNECTION HJ385002	
MOMENTARY START/STOP HJ385167	
Chapter 7 Installation Information	7-1
MOTOR.....	7-1
WIRING.....	7-1
SPECIAL CONSIDERATIONS FOR UL COMPLIANCE	7-2
Chapter 8 Basic Setting Up Procedure	8-1
CAUTION.....	8-1
PREPARATION	8-1
POWER ON.....	8-2
APPLICATIONS NOTES AND HINTS	8-3
Chapter 9 Trouble Shooting	9-1
Chapter 10 User Instructions	10-1
CURRENT LOOP AND ZERO SPEED OPTION CARD	10-1
Chapter 11 EMC and the 'CE' Mark	11-1

ISS.	MODIFICATION	ECN No.	DATE	DRAWN	CHK'D
1	Initial Issue of HA385113	6309	22.8.91	---	GDR
2	Corrections: Page 9 Block 3 5831 now "1" No Op-station "2" Including Op-station. Page 2 Max. Current Supply changed 9.5 to 8 and 5.5 to 5. Page 3 Gland Plate force fit into "base". Page 30 Revised Circuit Diagram.	7148	1.12.91	---	GDR
3	Replaced SSD name and address with Eurotherm Drives. Add UL special considerations page 23.	8087 8092	26.7.93	---	GDR
4	Added to page 7.2 number 5. Rewritten from Manuscript to Microsoft Word 6.0	10399	2.10.95	FEP	CC
5	Added section 11 EMC and the 'CE' Mark.	10137	28.11.95	FEP	MP
6	Page 5-6 corrected 0.75 to 1.5kW on 5831 1.5kW build drive.	10699	17.01.96	FEP	RBr
7	Page 11-1 added sentence "as confirmed ... chapter. Page 11-2 added new chart. Page 11-9 added "Generic Standard" columns and "** Achieved ... cable" Page 11-11 added Manufacturers EMC Declaration.	10856	29.04.96	FEP	
FIRST USED ON		MODIFICATION RECORD			
		582/583/5831 Product Manual			
 EUROTHERM DRIVES		DRAWING NUMBER			SHT. 1
		ZZ385113			OF 1

Chapter 2 Technical Details

ELECTRICAL SPECIFICATIONS

PARAMETER	5831						N/A	UNITS
	582			583				
	0.37kW	0.55kW	0.75kW	1.1kW	1.5kW	2.2kW		
INPUT RATINGS								
Supply Voltage 1 or 3-phase	220/240 ± 10%	220/240 ± 10%	220/240 ± 10%	220/240 ± 10%	220/240 ± 10%	220/240 ± 10%	Volts AC	
Max Supply Current 1 ph 3 ph	4 3.5	6 3.5	8 5	10 6	15 9	20 12	Amps AC (RMS)	
Fuse Assembly 1ph	LA058085 U014	LA058085 U014	LA058085 U014	LA058085 U024	LA058085 U024	LA058085 U024		
Fuse Assembly 3ph			LA058085 U014	LA058085 U014	LA058085 U014	LA058085 U024	1 per phase	
Fuse Replacement 1ph	CH430014 10A	CH430014 10A	CH430014 10A	CH430024 20A	CH430024 20A	CH430024 20A		
Fuse Replacement 3ph			CH430014 10A	CH430014 10A	CH430014 10A	CH430024 20A	1 per phase	
Supply Frequency	50/60	50/60	50/60	50/60	50/60	50/60	Hz	
Power Factor (lag)	0.9	0.9	0.9	0.9	0.9	0.9		
OUTPUT RATINGS								
Output Ratings	220/240	220/240	220/240	220/240	220/240	220/240	Volts AC	
Max Output Current	2.2	3.0	4.0	5.5	7.0	10.0	Amps AC	
Output Frequency	0-100/120	0-100/120	0-100/120	0-100/120	0-100/120	0-100/120	Hz	
Heat Dissipation	25	40	50	65	100	130	Watts	
Output Power	0.37	0.55	0.75	1.1	1.5	2.2	kW	
Overload	150 30s	150 30s	150 30s	150 30s	150 30s	150 30s	%	

ENVIRONMENTAL

HUMIDITY	:	85% R.H. at 40°C (non condensing).
ALTITUDE	:	Above 1000m Derate 1%/100m.
ATMOSPHERE	:	Non- flammable, non-corrosive and dust free.
OPERATING TEMPERATURE	:	0 to 40°C (Derate 1.5%/Degree above 40°C up to 55°C).
582/583 ENCLOSURE	:	Chassis Mounted either IP00 or IP20.
5831 ENCLOSURE	:	Panel Mounted IP54.

MECHANICAL

		Width(mm)	Height(mm)	Depth(mm)	Weight(kg)
582 IP00	:	163	237	84	1.0(1.2)
582 IP20	:	170	247	97	1.9(2.1)
582 IP20 with Gland Plate	:	170	280	97	2.1(2.3)
582 IP20 with Op Station	:	170	247	117	1.9(2.1)
582 IP20 with GP and OS	:	170	280	117	2.1(2.3)
583 IP00	:	272	250	156	4.6
583 IP20	:	272	250	165	5.2
583 IP20 with Op Station	:	272	250	185	5.3
5831 IP54	:	188	255	150	5.5

Weights in brackets refer to 0.75kW version

MOUNTING ORIENTATION	:	Vertical
AIR FLOW CLEARANCE	:	70mm
POWER TERMINATIONS	:	Screw Connectors for 2.5mm wire 582 ² or 4mm ² 583/5831.
582 COVER REMOVAL:	:	Press small blunt instrument (e.g. screwdriver) into slot in side of cover and pull gently - see HG057848 for slot location.
583 COVER REMOVAL	:	Apply sensible pressure to left-hand side of cover until it comes free from lip of side plate. See drawing HG058065F.
5831 COVER REMOVAL	:	Four screws are provided at the corners of the cover when removed the cover can be lifted to allow access to the earth connection.
TERMINAL PLATE REMOVAL 582/583	:	Rotate either the single screw in the centre of the 583 plate, or the two side screws on the 582 to remove and gain access to the terminals and user adjustments.
GLAND PLATE ACCESS HOLES 582 ONLY	:	On the 582 a gland plate (LA057730) can be fixed to the mounting plate to accept 3 x 0.5" NPT conduit connectors, or, using adaptor ring BH058121 in each position, 3 x M20 conduit connectors. If a gland plate is used the old terminal plate should be discarded and the new one provided in the kit used.
GLAND PLATE ACCESS 5831	:	On the 5831 a gland plate is provided as a force fit into base.

Chapter 3 Outline Drawings

HG057813E 582 IP00 Outline Drawing

HG057848F 582 Manual Outline Drawing

HG058064F 583 IP00 Outline Drawing

HG058065F 583 IP20 Outline Drawing

HG385059F 5831 Outline Drawing

Chapter 4 Product Code

	582	583	5831
<u>Block 1</u>	3 Digits identifying basic product (582)	3 Digits identifying basic product (583)	4 Digits identifying basic product (5831)
<u>Block 2</u>	4 Digits identifying the output power. 0375 - 0.375kW 0550 - 0.55kW 0750 - 0.75kW	4 Digits identifying the output power. 1100 - 1.1kW 1500 - 1.5kW 2200 - 2.2kW	4 Digits identifying the output power. 0375 - 0.375kW 0550 - 0.55kW 0750 - 0.75kW 1100 - 1.1kW 1500 - 1.5kW
<u>Block 3</u>	Single digit specifying single or 3-phase input. 1 - single phase 3 - three phase	Single digit specifying single or 3-phase input. 1 - single phase 3 - three phase	Single digit identifying Op-station. 1- No Op-station 2 - Including Op-station
<u>Block 4</u>	Single digit specifying type of enclosure. 0 - IP00 1 - IP20 2 - IP20 with Op-station	Single digit specifying type of enclosure. 0 - IP00 1 - IP20 2 - IP20 with Op-station	2 Digits to indicate option card requirements. 00 - No option card fitted 01 - Current Loop Option (4 - 20mA)
<u>Block 5</u>	2 Digits to indicate option card requirements. 00 - No option card fitted 01 - Current Loop Option (4 - 20mA)	2 Digits to indicate option card requirements. 00 - No option card fitted 01 - Current Loop Option (4 - 20mA)	2 Digits identifying special options. 00 - No special options 01 - 99 Documented special options
<u>Block 6</u>	2 Digits identifying special options 00 - No special options 01 - 99 Documented special options	2 Digits identifying special options. 00 - No special options 01 - 99 Documented special options	

Chapter 5 Terminal Descriptions

TERMINAL DESCRIPTIONS 582/583

1. Drive Healthy (582 only) : Open collector transistor output which is pulled low to indicate drive healthy. 250mA maximum at 24V. Connect external 0V to drive 0V (terminal 11).
This terminal is not used on the 583. See drive healthy relay terminals overleaf.
2. Run : Digital input to enable drive: Switch to +24V to enable. Connection via momentary contact may be employed; see diagram number HJ385167D.
3. Stop : Digital input to stop drive: Momentary open circuit to stop. Leave open circuit if single Run switch (on/off) is employed.
4. Direction : Digital input to control phase rotation: Connect to +24V to reverse direction of motor shaft.

NOTE Digital inputs sink approximately 5mA at 24V.

5. +10V Ref : Precision 10V reference for external potentiometer supply. Maximum loading: 10mA. Short circuit protected.
6. Speed Setpoint : Analogue input to control frequency of 3-phase output.
0 - 10V represents 0 - 100% motor speed.
Nominally 10K potentiometer input.
7. 0V Ref : Zero Volts for analogue references.
8. Ramp Output : Analogue output representing the output frequency of the drive. 0 - 10V represents 0 - 100/120Hz, depending on position of SW1. Maximum loading: 10mA.
9. Trim : Analogue input which may be used as a local trim of the speed to allow drives to be cascaded from a master reference.
0 - 10V represents 0 - 100% speed **increase**.
10. +24V Supply : Unregulated 24V supply for RUN, STOP, DIRECTION switches. Only 20mA available, thus this output is not intended to be used to drive healthy relay.
11. Gnd : Zero volt reference for digital inputs, (RUN, STOP, DIRECTION) and healthy output.

12. } User Option Connections : These pins are specified by the option cards and may be used for a 4 - 20mA input. serial comms or other specialised functions.
13. }
14. }
15. }
16. }

17. } (583 only) : Used to control a 5801 brake unit.
18. }

- Hesto Conn. } (582 only) : Used to control a 5801 brake unit.
-

All terminals are suitable for 2.5mm² wire (12 AWG) recommended tightening torque 0.5Nm (4.5 lb-in).

TERMINAL DESCRIPTIONS 5831

1. Run : Digital input to enable drive: Switch to +24V to enable. See diagram number HJ385002D.
2. Stop : Digital input to stop drive: Momentary open circuit to stop. Leave open circuit if single Run switch (on/off) is employed.
3. Direction : Digital input to control phase rotation: Connect to +24V to reverse direction of motor shaft.

NOTE Digital inputs sink approximately 5mA at 24V.

4. +10V Ref : Precision 10V reference for external potentiometer supply. Maximum loading: 10mA. Short circuit protected.
5. Speed Setpoint : Analogue input to control frequency of 3-phase output. 0 - 10V represents 0 - 100% motor speed. Nominally 10K potentiometer input.
6. 0V Ref : Zero Volts for analogue references.
7. Ramp Output : Analogue output representing the output frequency of the drive. 0 - 10V represents 0 - 100/120Hz, depending on position of SW1. Maximum loading: 10mA.
8. Trim : Analogue input which may be used as a local trim of the speed to allow drives to be cascaded from a master reference. 0 - 10V represents 0 - 100% speed **increase**.
9. +24V Supply : Unregulated 24V supply for RUN, STOP, DIRECTION switches. Only 20mA available, thus this output is not intended to be used to drive healthy relay.
10. Gnd : Zero volt reference for digital inputs, (RUN, STOP, DIRECTION) and healthy output.

11. }
 12. }
 13. } User Option : These pins are specified by the option cards and may be used for a 4 -
 14. } Connections : 20mA input. serial comms or other specialised functions.
 15. }

16. } : Used to control a 5801 brake unit.
17. } : See connection diagram HJ385002.

All terminals are suitable for 2.5mm² wire (12 AWG) recommended tightening torque 0.5Nm (4.5 lb-in).

POWER TERMINALS**582**

Input Terminals	:	L1 (L) L2 (N) L3	{	220/240V AC \pm 10% Single phase L and N 3-phase L1, L2, L3
Brake Connections	:	DC + DC -	{	DC Link Positive DC Link Negative
Motor Connections	:	M1 (U) M2 (V) M3 (W)	{	3-Phase 0 to 220/240V AC 0 to 100/120HZ

NOTE: The 582 has no chassis ground except when a gland plate is fitted. Power terminal blocks are suitable for 2.5mm² wire (12 AWG) recommended tightening torque 0.5Nm (4.5 lb-in).

583¹

Input Terminals	:	L1 (L) L2 (N) L3	{	220/240V AC \pm 10% Single phase L and N 3-phase L1, L2, L3
Brake Connections	:	DC + DC -	{	DC Link Positive DC Link Negative
Health Relay Health Relay	}	HEALTH ²		Contact rating 3A 250V AC/30V DC
Motor Connections	:	M1 (U) M2 (V) M3 (W)	{	3-phase 0 to 220/240V AC 0 to 100/120Hz

NOTE: The 583 can be grounded at the heatsink. Power Terminal Blocks are suitable for 4mm² wire (10 AWG) recommended tightening torque 0.5Nm (4.5 lb-in).



5831¹

Input Terminals	:	L1 (L) L2 (N) L3	{	220/240V AC \pm 10% Single phase L and N 3-phase L1, L2, L3
Motor Connections	:	M1 (U) M2 (V) M3 (W)	{	3-phase 0 to 220/240V AC 0 to 100/120Hz
Health Relay Health Relay	}	HEALTH ²		Contact rating 3A 250V AC/30V DC
Brake Connections (Faston Connectors)	:	DC + DC -	{	DC Link Positive DC Link Negative

NOTE: The 5831 can be grounded at the base plate. Power terminal blocks are suitable for 4mm² wire (10 AWG) recommended tightening torque 0.5Nm (4.5 lb-in).

- NOTES:
1. The ground terminal is indicated by the IEC grounding symbol thus:- 
 2. Contacts closed when drive is healthy.

CUSTOMER ADJUSTMENTS

- P1** Low Speed/Frequency Voltage Boost : Rotate clockwise to increase the voltage/frequency ratio at low speed; this gives the motor more low speed torque. Excessive adjustment may cause the current limit to be reached and the motor may not turn.
- V_B
- P2** Current Limit : Rotate clockwise to increase the maximum current available from the drive. If current demand exceeds current limit, the speed/frequency will be reduced to keep the current within this maximum. Adjustment 50% to 150% of rated current. **Note:** Motor may not turn if turned fully anti-clockwise.
- $I \Delta$
- P3** Maximum Speed : Rotate clockwise to increase maximum speed/frequency at which drive will run with 100% speed demand. Adjustment is from 0 - 100/120Hz. In the event of conflict between Minimum and Maximum settings, Maximum will always override.
- $N \Delta$
- P4** Minimum Speed : Rotate clockwise to increase minimum speed/frequency at which drive will run with zero speed demand. Adjustment is from 0 - 100/120Hz.
- $N \nabla$
- P5** Ramp Up Time : Rotate clockwise to increase the time taken to ramp up to speed/frequency. Output adjustment range is either 0.1 - 4 seconds or 2.5 - 100 seconds depending upon position of switch 4.
- 
- P6** Ramp Down Time : Rotate clockwise to increase the time taken to ramp down to speed/frequency. Output adjustment range is either 0.1 - 4 seconds or 2.5 - 100 seconds depending upon position of switch 5.
- 

WARNING

THE SIX TRANSISTOR HEATSINKS OF THE 582 ARE LIVE. CARE SHOULD BE TAKEN WHEN MAKING ADJUSTMENTS TO AVOID CONTACT WITH THESE PARTS.

OPTION SWITCHES

Switch positions are only read at power-on, so if any adjustment of switches is required, the power must be removed before doing so.

SW1 (OFF) **Base Frequency** : 50Hz
 (ON) : 60Hz

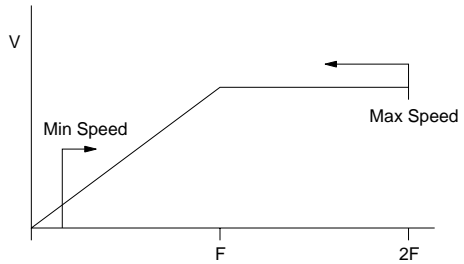
SW2 (OFF) **SW3** (OFF) **Normal** : 

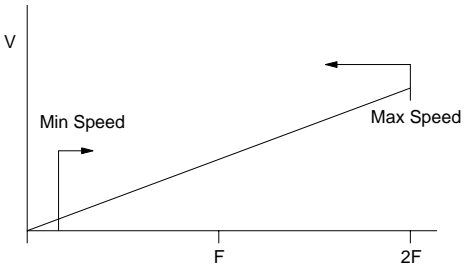
SW2 (OFF) **SW3** (ON) **Linear** : 

SW2 (ON) **SW3** (OFF) **Fan Law** : 

SW2 (ON) **SW3** (ON) **Reserved**

SW4 (OFF) **Ramp Up Range** : 0.1 - 4 sec
 (ON) : 2.5 - 100 sec *to base freq.*

SW5 (OFF) **Ramp Down Range** : 0.1 - 4 sec
 (ON) : 2.5 - 100 sec *to base freq.*

SW6 (OFF) **Reserved** : **THIS SW MUST REMAIN OFF.**

SW7	SW8	} - Stopping Mode	:	Coast to Stop.
(OFF)	(OFF)		:	Ramp down to Stop.
(OFF)	(ON)		:	Ramp to zero followed by 2 sec DC holding pulse.
(ON)	(OFF)		:	DC Injection Braking. (See Note 2).
(ON)	(ON)		:	

SW9 **Ramp Hold** : This switch should normally be off. (See Note 3).

SW10	SW11	SW12	Power Output	Drive
(OFF)			: 0.37kW	} 582 0.37/0.55kW ¹
(ON)			: 0.55kW	
(OFF)			: 0.55kW	} 582 0.55/0.75kW ¹
(ON)			: 0.75kW	
(OFF)	(OFF)	(ON)	: 0.75kW	} 583 1.1/1.5kW ¹
(ON)	(OFF)	(ON)	: 1.1kW	
(ON)	(ON)	(ON)	: 1.5kW	
(OFF)	(ON)	(OFF)	: 1.5kW	} 583 1.5/2.2kW ¹
(ON)	(ON)	(OFF)	: 2.2kW	
(OFF)	(OFF)	(ON)	: 0.37kW	} 5831 0.75kW ¹
(ON)	(OFF)	(ON)	: 0.55kW	
(ON)	(ON)	(ON)	: 0.75kW	
(OFF)	(OFF)	(ON)	: 0.75kW	} 5831 1.5kW ¹
(ON)	(OFF)	(ON)	: 1.1kW	
(ON)	(ON)	(ON)	: 1.5kW	

NOTES:

1. Controllers are shipped with switches set to the lower rating. Set switches to the required rating before use. Setting of the switches on the 583 1.1/1.5kW version to 2.2kW will cause damage and invalidate the warranty.

2. DC injection braking may be selected by setting switches 7 and 8 to the ‘on’ position. When a stop command is received, the drive will apply a low frequency braking current to the motor, until the shaft is almost at a standstill. The amount of braking is controlled by the current limit setting.

 DC current is then applied for a short time, to bring the shaft finally to a standstill. This is controlled by the boost adjustment.

3. To achieve very fast ramp up rates, e.g., 0.1 seconds, it may be necessary to set this switch to ‘on’.

Chapter 6 Diagnostics

LED1	Power On	:	Illuminated when power is present on drive.
LED2	Status	:	Illuminated when drive is healthy and running; off when drive is healthy and disabled. Alarm conditions are indicated via an optical code flash sequence: Instantaneous overcurrent : 2 flashes followed by pause. DC link overvoltage : 3 flashes followed by pause. Ixt overload : 4 flashes followed by pause. Motor stalled : 5 flashes followed by pause. Ixt integrator : Status LED flashing but drive still running indicates that Ixt integrator is operating. The drive will remain running only for a limited period of time depending on the level of overload.
LED3	Healthy	:	Illuminated when drive is healthy. Off in any alarm conditions.

NOTE: The LED on the left of the drive indicates that there is still charge on the DC link capacitor. While this LED is illuminated danger of electric shock exists. No work must be carried out on the drive in this condition.

Chapter 7 Installation Information

Before connecting AC supply to this equipment.

1. Ensure good airflow over heatsink. Maintain clearance above and below controller to 70mm.
2. Operating temperature range 0 to + 40°C.
3. Protect from airborne pollutants.
4. Avoid vibration.

MOTOR

1. Ensure motor is mechanically secure and mounted according to manufacturers specifications and practice.
2. Ensure that motor is connected for 220/240V 3-phase operation.
3. Check obstructions in motor vents to maintain cooling air path.
4. Auxiliary cooling must be provided for motor if constant torque is required and low speed operation is possible, see motor manufacturers derating specification.
5. Ensure motor is free to rotate and that pulleys and couplings are correctly aligned.
6. Ensure transit damage has not occurred to motor windings or connections. Disconnect the controller before carrying out electrical measurements e.g., insulation resistance.

WIRING

1. For EMC installation refer to the section “EMC and the CE Mark”.
2. For information on the wiring of the controllers refer to:-
 - a) 582 - HJ057820
 - b) 583 - HJ058055
 - c) 5831 - HJ385002

A general purpose diagram of momentary start/stop is given in diagram HJ385167.

3. Control cabling 0.75 sq.mm. minimum.
4. Power cable to be minimum 300V AC rated at 1.1 x controller current.
5. HRC fuses or circuit breakers of the correct rating are recommended for incoming supply protection.
6. Isolated control wiring should not be run close to the power cabling. If screened cables are used (recommended on setpoints and meters) connect screens to earth only at controller end.
7. Eurotherm Drives supply fuse assemblies which can be bulkhead mounted and also act as convenient supply isolators. For fuse part numbers refer to Electrical Specification on page 2-1. If preferred circuit breakers of appropriate rating may also be used as an alternative to fuses.
8. A cable assembly Eurotherm Drives reference LA056140 is required when connecting the 582 to the 5801 Brake Unit. The cable assembly consists of an insulation displacement connector and a twisted pair of red and black cable. The insulation displacement connector fits into the socket SK1 on the 582 and the red and black cable end connect to the 5801. The red cable connects to D+, the black cable to D-.

SPECIAL CONSIDERATIONS FOR UL COMPLIANCE

1. Power Cabling to be rated at 1.25 x controller current.
2. An external running motor overload protective device must be provided by the installer. This device may be:-
 - i) A motor thermistor monitoring motor temperature.
 - ii) A thermal overload monitoring motor current.
 - iii) Any device which is considered adequate by the installer or local inspector to comply with the National Electric Code and/or local code requirements.
3. Where a protective ground terminal is provided as indicated by the IEC grounding symbol, the controller should be grounded via a cable of suitable rating as defined by the National Electric Code.
4. Class T Branch Circuit fuses rated at 20A for 1.1 and 1.5kW controllers and 30A for 2.2kW controllers must be provided by the installer.
5. 583 Products are suitable for use on a circuit capable of delivering not more than 5000 RMS symmetrical amperes, 240 volts maximum.

Chapter 8 Basic Setting Up Procedure

BEFORE ATTEMPTING TO CONNECT POWER, CAREFULLY CHECK

1. Main power supply voltage is correct.
 2. Motor is of correct voltage rating and is connected in either star or delta as appropriate.
 3. All external wiring circuits:-
 - Power connections
 - Control connections
 - Motor connections
- NOTE:- Completely disconnect the controller before point to point checking with a buzzer or when checking insulation with a meggar.
4. Check for damage to equipment.
 5. Check for loose ends, clippings, drilling swarf, etc., lodged in the drive or ancillary equipment.
 6. If possible check that the motor can be turned freely and that cooling fan is intact and free of obstructions.

CAUTION

1. That rotation of the motor in either direction will not cause damage.
2. That nobody else is working on another part of the equipment and will be affected by powering up.
3. That other equipment will not be adversely affected by powering up.

PREPARATION

1. Prevent application of the main power supply by removal of the supply fuses or isolate via supply circuit breaker.
2. Disconnect the load from the motor shaft, if possible.
3. Check switch selection:-

SW1	Supply Frequency 50/60Hz.
SW2	} V/F Characteristics.
SW3	
SW4	Up Ramp.
SW5	Down Ramp Range.
SW6	OFF
SW7	} Stopping Mode
SW8	
SW9	OFF

SW10

SW11

SW12

Power Rating

Controllers are shipped from Eurotherm Drives with switches set to the lower power rating for each power rating.

4. Pots are set:-

P1	Boost	Anticlockwise	(no boost)
P2	Current Limit	Clockwise	(full current)
P3	Maximum Speed	Mid	(approximately base speed)
P4	Minimum Speed	Anticlockwise	(zero minimum speed)
P5	Ramp Up	Clockwise	(slow ramp)
P6	Ramp Down	Clockwise	(slow ramp)

5. Check external run contacts are open.

6. Check external setpoints are all zero.

POWER ON

Once all the proceeding steps are completed and understood, the supply fuses/circuit breaker may be replaced and power applied to the drive. Although fairly general, the following assumes a single drive and motor configuration.

1. At switch on the “Power ON” (LED 1) should illuminate as should DC Link charged LED.

2. Close RUN contact, either give drive small speed demand via speed potentiometer or rotate slightly clockwise minimum speed potentiometer. Motor should rotate slowly.

If motor rotates in wrong direction either:- Swap two of the output phases (U, V, W).
Close direction switch.
Power down and hard wire terminal 4 to terminal 10.

3. With speed potentiometer set to zero set minimum speed to desired minimum running speed of motor.

4. On applications where high starting torque is required increase of low voltage BOOST may be necessary. Excessive adjustment may cause drive to trip on over current and will cause motor to overheat if left running in this condition.

5. Set speed potentiometer to 100% and either increase or decrease maximum speed potentiometer to set maximum running speed of the motor.

6. By varying the speed demand potentiometer the ramp times may be set by adjustment of Ramp Up/Down potentiometers.

7. If Ramp down times cannot be achieved without the drive tripping on over voltage alarm, then a 5801 brake unit must be fitted.

8. Stopping modes may be selected via SW7 and SW8. Power must be removed before this adjustment is made.

9. If the motor used is rated below the rating of the inverter a reduction in current limit (anti-clockwise adjustment of P2) will give electronic protection of the motor, and a crude form of torque limit. If more than one motor is used, each must be protected via an appropriate overload.

APPLICATION NOTES AND HINTS

1. Always use gold flash relays, or others designed for low current operation (5mA) on all control wiring.
2. Use screened cable on all control wiring.
3. Place control and power wiring in different ducts.
4. Isolation between inverter and motor may be employed although it is recommended that this is operated when motor is stationary or in emergencies only. Note that dangerous voltages are present within the drive for a few minutes after the power is removed.
5. Occasionally a motor line-choke (582 - CO055930) (583 - CO055931) is recommended to prevent nuisance over-current tripping when motor cables exceed 20m in length. 20m is a nominal length; some installations may be better, others worse.
6. All power factor correction equipment must be removed from the motor before an inverter can be used.
7. Motors with low efficiency and small $\cos \theta$ (power factor) should be avoided since they require a larger KVA rated inverter to produce the correct shaft kW.
8. On applications where synchronous, slip ring, pole change or brake motors are used, please consult with Eurotherm Drives Limited prior to installation.

Chapter 9 Troubleshooting

PROBLEM	POSSIBLE CAUSE	REMEDY
Controller will not Power up. No "Power ON" LED illuminated.	Supply fuses/breaker. No supply. Incorrect supply voltage.	Wrong rating. Check supply availability. Check supply voltage.
MOTOR WILL NOT RUN WHEN POWER APPLIED		
All LEADS ON.	No motor connection. Maximum speed set at zero. Motor jammed.	Check motor connections. Increase to approximately 10%. Free obstruction.
LED1 ON LED2 OFF LED3 ON	Run switch not closed. Connection with momentary push buttons incorrect.	Check connection between terminal 2 and 10. Check wiring.
LED1 ON LED2 Flashing LED3 OFF 2 FLASHES: Over current	Boost set too high. Acceleration rate too high. Motor winding short circuit.	Reduce boost setting. Reduce ramp up setting. Disconnect drive and meggar motor.
3 FLASHES: Over voltage	Supply voltage too high. Deceleration rate too high.	Check supply voltage. Reduce ramp down setting. Fit brake unit. Check brake unit and its resistors.
4 FLASHES: lxt	Overspeeding fan/pump. Over sized motor fitted. Load too large.	Reduce maximum speed setting. Check motor rating and position of switch 10. Reduce motor shaft loading.
5 FLASHES: Motor Stalled	Current limit too low.	Increase current limit setting.
LED2 "Winking"	Drive in overload condition. Load too large. Boost setting too high.	Reduce motor shaft loading, increase ramp up time. Reduce boost setting.

PROBLEM	POSSIBLE CAUSE	REMEDY
DC INJECTION BRAKING DIFFICULTIES		
Motor starts to brake, then cuts out before the braking is completed, leaving the motor to coast to a stop	Internal time out has acted. During the braking sequence, the ramp acts as a time-out, by ramping down from the setpoint to zero. The drive then waits a further 5 seconds, and stops the drive if the braking is not completed.	Increase ramp down time. Time-out will operate in ramp time from setpoint, plus 5 seconds.
Motor brakes almost to a standstill, but does not quite stop before the drive cuts out.	Not enough boost. When the shaft has almost reached standstill, the degree of braking is determined by the boost pot.	Increase boost.
Braking does not operate at all. Motor coasts to rest	Motor rating smaller than drive rating. Not enough boost. Current limit too high for motor.	Select correct rating on DIL switches. Turn down current limit. Increase boost. Turn down current limit.
Motor brakes but crawls at a low speed before the drive cuts out.	Boost potentiometer setting and current limit settings incompatible.	Reduce boost setting or increase current limit setting, or both.
Motor runs off load but stalls On-Load with no indication.	Motor connections incorrect. Check motor data.	Standard motor requires Delta Connection for 220V, Star Connection for 415V
Despite low inertia, it is not possible to achieve the fastest ramp up rates.	The ramp up rate is being slowed by the current limit.	Set switch 9 to 'on'.

Chapter 10 User Instructions

CURRENT LOOP AND ZERO SPEED OPTION CARD

INTRODUCTION

The current loop and zero speed option card is intended to provide a speed reference and a zero speed indication for the Eurotherm Drives 582/3 series of inverters.

Current loop format is configurable via the switches provided.

OPTION SWITCHES

Four current loop formats are available with this option card and are selected in the following way:-

	SW1	SW2	SW3	SW4
0.20mA	OFF	OFF	ON	OFF
4-20mA	ON	ON	ON	OFF
20-0mA	OFF	OFF	OFF	ON
20-4mA	ON	ON	OFF	ON

The 0/4-20mA formats will give an increase in speed for an increase in mA.

The 20-4/0mA formats will give an increase in speed for a decrease in mA.

ELECTRICAL SPECIFICATION

Accuracy	± 2% of FS
Input Impedance	100 Ω
Common Mode Voltage	30V
Bandwidth	20Hz
Zero Speed	N/O Contact
	24V 2A contact
	De-energized at Zero Speed

FITTING INSTRUCTIONS

Configure option switches and insert the connector onto the option pins provided on the inverter. When fitted the components should be on the bottom side of the board and secured by a push fit of nylon supports. If fitted incorrectly possible damage may occur.

Wiring Diagram over page:-

TERMINALS
CONTROL
INVERTER

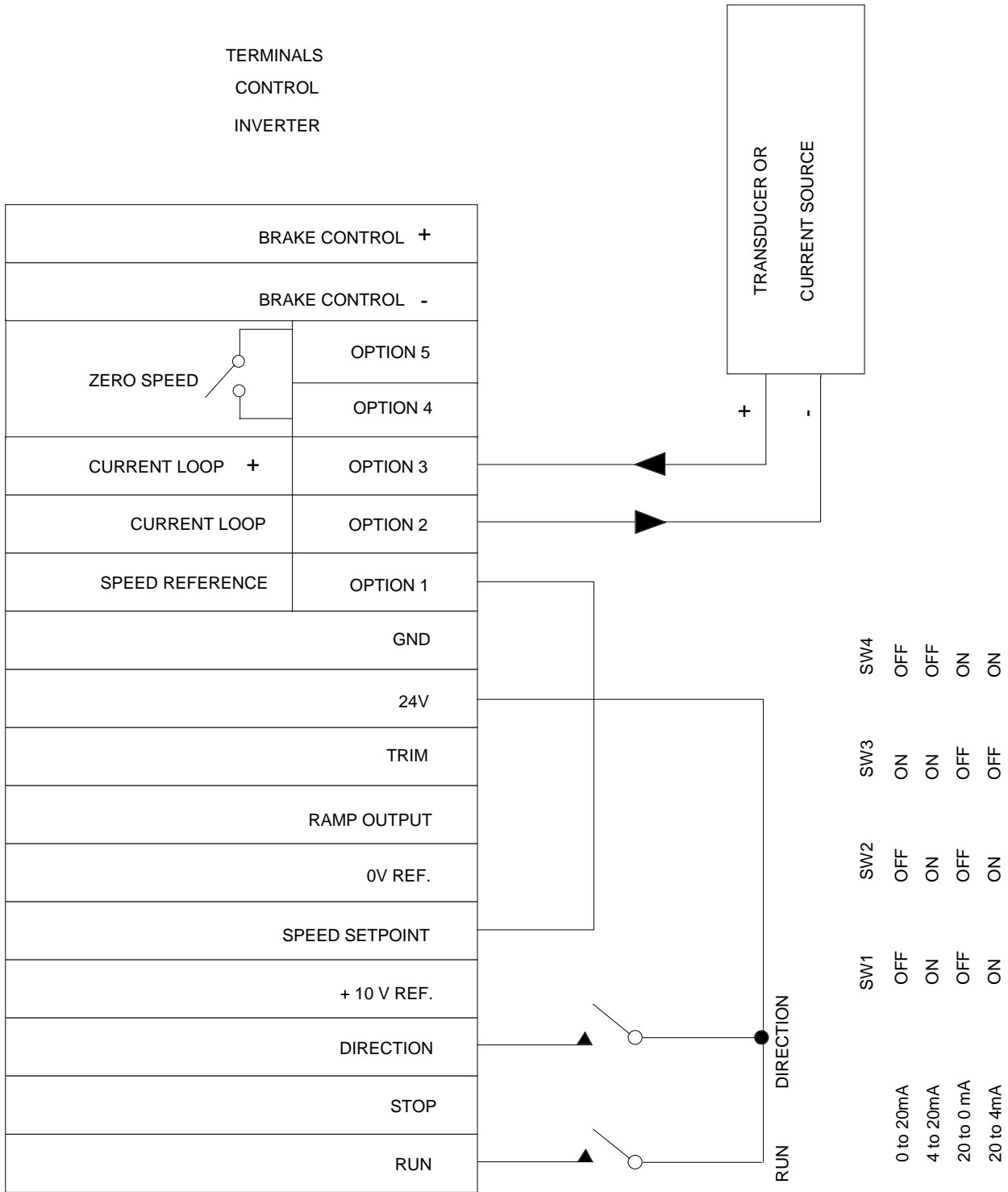

Chapter 11 EMC and the CE Mark

'CE' EMC RESPONSIBILITY

The subject of CE marking and EMC is explored in more detail in a separate Eurotherm Application manual entitled 'EMC Installation Guidelines for modules and systems', part number HA388879, available from your local Eurotherm Drives office. The following sections are the minimum necessary for installation and basic understanding.

Eurotherm Drives are adhering to the CEMEP recommendations on 'CE' marking for EMC.

According to SI No. 2372, implementing the EMC directive into UK law, the requirement to CE mark for EMC, applies only to **relevant apparatus** that has '**intrinsic function**' to the **end user** and which is placed on the market (**supplied**). The majority of drive modules/systems sold by Eurotherm Drives will be incorporated into a higher system/apparatus or machine which includes (at least) the motor, cable and a driven load before providing intrinsic function to the end user. As such the majority of Eurotherm Drives products are categorised as **components** (CEMEP validity field 2) and it would be incorrect for Eurotherm Drives to apply the CE mark or produce an EC Declaration of Conformity in respect of EMC. It is the manufacturer/supplier/installer of the relevant apparatus (with the intrinsic function to the end user) who must demonstrate conformance to the EMC directive

However, in a minority of cases, single drives may have intrinsic function to the end user. An example is that of '**add on**' intrinsic function, where an existing fixed speed motor application (such as a fan or a pump) is converted to variable speed with an **add on** drive module (CEMEP validity field 1). In this application Eurotherm Drives CE mark its drive module and issue an EC declaration of conformity. Because the validity of the 'CE' mark for EMC is not known when the product is manufactured, the 'CE' mark will be applied via the product manual, and will not be on the product label. From 1997, when the 'CE' mark for the Low Voltage Directive becomes mandatory, the CE mark will appear on the product label, but its validity for EMC can only be identified from the product manual.

The validity of the 'CE' mark can be identified from the flowchart in figure A, refer to SI No. 2372 for clarification of relevant apparatus.

To assist manufacturers/suppliers/installers of relevant apparatus, Eurotherms 582, 583 and 5831 drive modules are EMC compliant to EN50081-1 (1992), EN50082-1 (1992), EN50081-2 (1994) and prEN50082-2 (1992), when fitted with the specified filter and installed according to these instructions, as confirmed by the manufacturers EMC Declaration to be found at the end of this chapter.

Manufacturers/suppliers/installers of relevant apparatus (CEMEP validity fields 3 & 4) may use this compliance as a basis for their own justification of overall compliance with the EMC Directive.

It must be clearly understood by the customer before installation commences who is legally responsible for conformance with the EMC Directive. Misappropriation of the CE mark is a criminal offence.

Figure A Eurotherm EMC 'CE' Mark Validity Chart

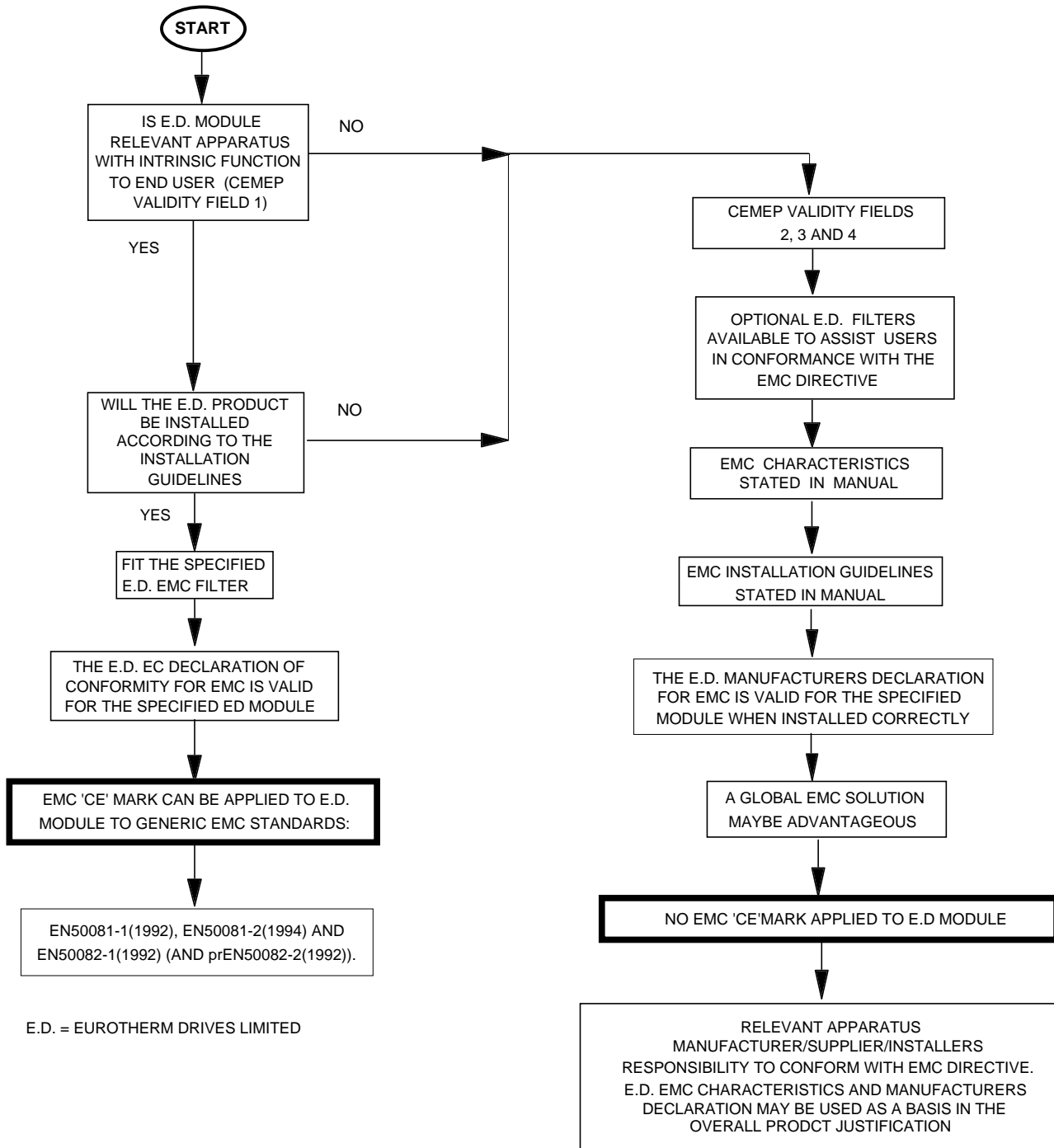

FILTER SELECTION

The following AC supply filters are available to comply with the mains terminal limits of EN55011 (1991) Class B. For the Eurotherm Drives EMC 'CE' mark to be valid the fitment of the specified AC supply filter is **mandatory**.

Eurotherm Product	Rating	Eurotherm Filter Part Number
582	single phase 0.55kW & 0.75kW	CO389108
5831	single phase 0.75kW & 1.5kW	CO389108
583	single phase 1.5kW	CO389108
583	single phase 2.2kW	CO389110

FILTER INSTALLATION

Filter mechanical mounting details are shown in figures B and C.

Figure B Mounting Details for Filter Part Number CO389108

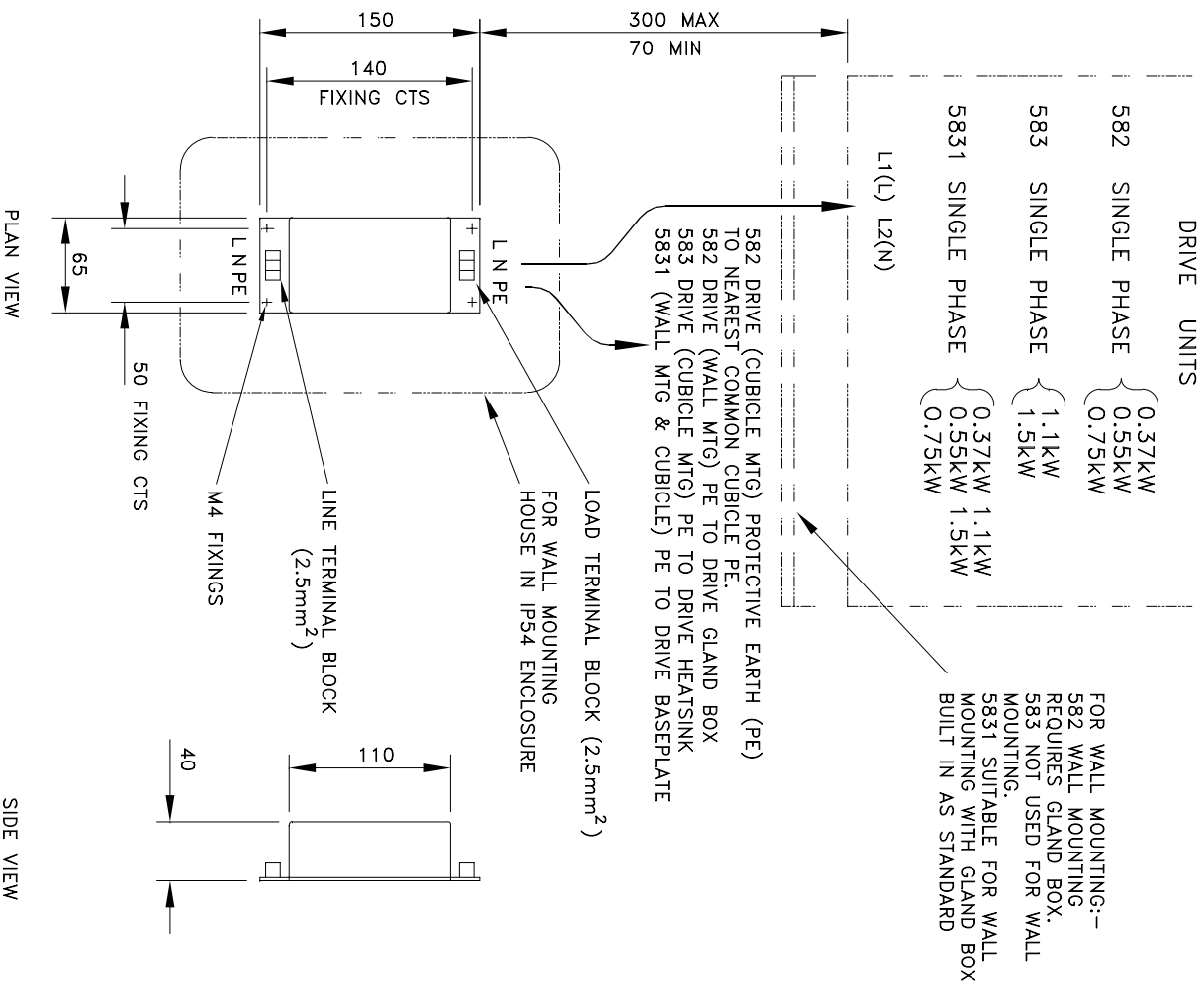

FILTER MOUNTING DETAILS
 Part No CO389108
 FOR DRIVE UNITS 582,583 & 5831

Figure C Mounting Details for Filter Part Number CO389110

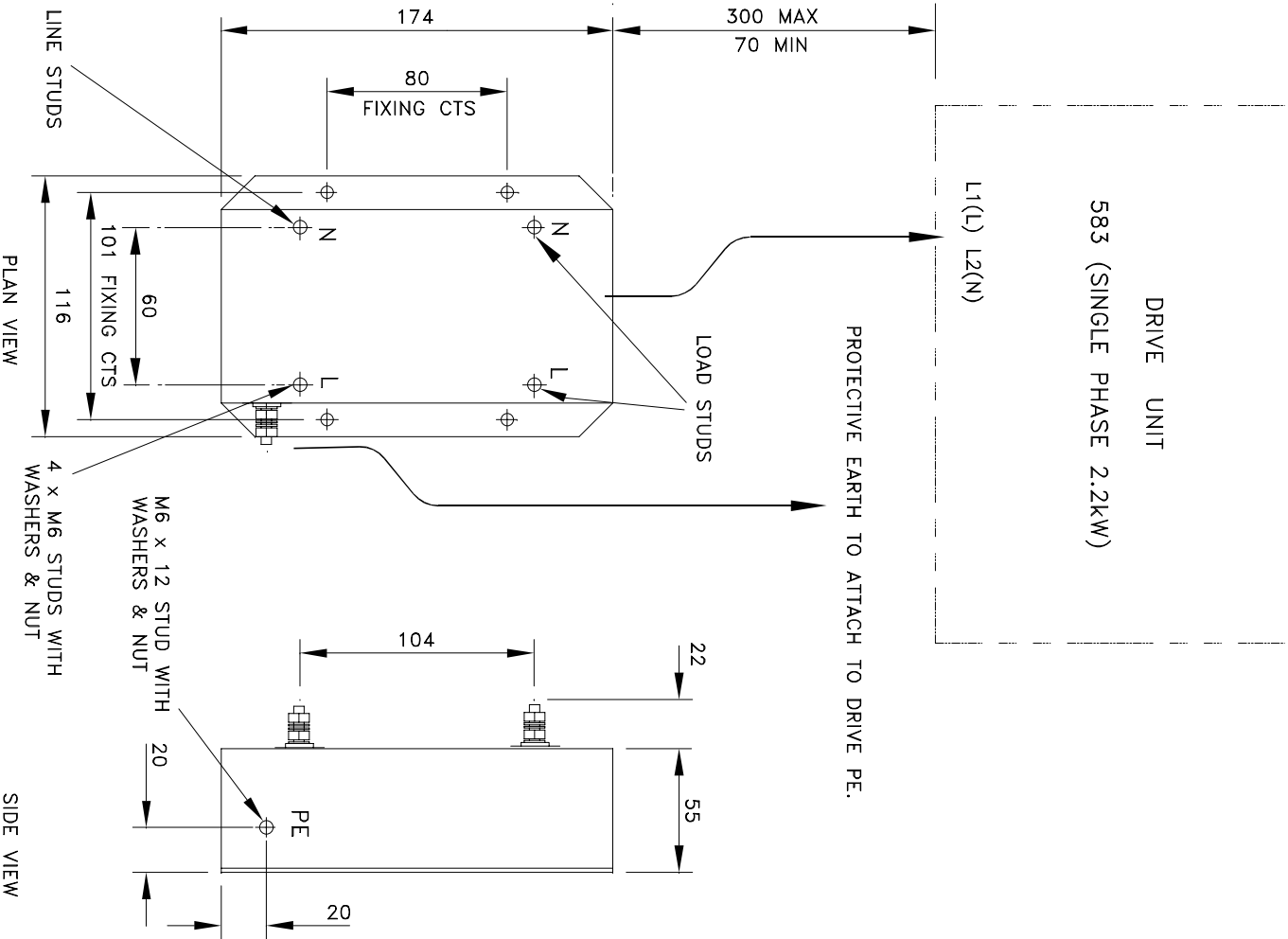

FILTER MOUNTING DETAILS

Part No CO389110

FOR DRIVE UNIT 583 (SINGLE PHASE 2.2kW)

For both AC and DC drives the conducted emissions increase with motor cable length. EMC conformance to the stringent limits applied by Eurotherm Drives is only guaranteed up to a maximum cable length of 5m, but can be increased dependent on reduced limits being applied. This length can be still further increased by the use of output filters and chokes. Refer to the separate Eurotherm Application manual entitled 'EMC Installation Guidelines for modules and systems', part number HA388879 for more information



WARNING 1: The AC supply filters produce earth leakage currents in excess of 3.5mA.



WARNING 2: The AC supply filters contain capacitors phase to phase and phase to earth. Discharge resistors are fitted, but the filters or cabling should **not be touched** for a period of 1 minute after the removal of the AC supply.



WARNING 3: The AC supply filter must only be used with a **permanent earth** connection. Permanent earthing can be achieved by either a) using a copper protective earth conductor of at least 10mm² or b) installing a second conductor in parallel connection with the protective conductor to a separate protective earth terminal. The conductor shall on its own meet the requirements for a protective earth conductor.



WARNING 4: Eurotherm Drives **do not recommend** the use of RCDs. Special RCDs (Type B according to the second amendment of IEC755) are required due to the AC and DC components flowing in the earth leakage current. All loads requiring protection with the RCD would be at risk.



WARNING 5: Eurotherm Drives only guarantee the thermal performance of the EMC AC supply filter up to a maximum equivalent cable length of 150m.

Wall Mount (582/5831)

For wall mount applications filters CO389108, CO389110 will require mounting in a separate suitable enclosure, and all connections made with conduit. In addition the optional 582 gland box must be used. Ensure the filter to drive cable is passed through conduit mounted between the filter and the drive gland box. This cable must be as short as possible (0.3m maximum) and segregated from all other cables.

Cubicle Mount (582/583)

Ideally the filter will be mounted onto a metallic back panel in the cubicle to which the drive is mounted too. The RF connection between the drive and filter will be usefully enhanced by scraping away any paint/insulation between the filter and drive mounting points on the panel. Liberally apply petroleum jelly over the mounting points and securing threads to prevent corrosion.

SCREENING

All Eurotherm Drives modules comply with the radiated emission limits of EN55011 (1991) Class A when installed in free air (Wall Mounted) according to these instructions, using an AC supply filter and screened motor cable, but using unscreened control and signal cabling. Products which meet the limits of Class A can be made to meet the more stringent limits of Class B by simply mounting inside an enclosure with 10dB attenuation between 30 and 100MHz (which

would typically be the attenuation provided by a standard metal cubicle) and screening any control and signal cabling outside of the cubicle (including any optional tacho, encoders or communications connections etc.).

On AC drives, in addition to screening the motor cable, any connections to the DC link must also be screened/armoured, with the screen connected at both ends (e.g. to the protective earth of the dynamic brake resistor).

Safety earthing always takes precedence over EMC earthing.

Screen to earth connections via 360° bonding is 75% more effective than earthing via pigtails. The integrity of the screen should be maintained over the entire length of the cable. If the cable is broken to insert contactors, chokes, fuses etc., then the screen must be connected over the shortest possible distance. Note some hazardous area installations may preclude direct earthing at both ends of the screen, in this case earth the other end via a 1µF, 50VAC capacitor.

If a shielded cable is not available, lay unshielded motor cables in a metal conduit which will act as a shield. The conduit must be continuous with a direct electrical contact at both ends. If links are necessary use braid with a minimum cross sectional area of 10mm².

Wall Mount (582/5831)

The cable between the wall mount drive module and the motor must be screened or armoured. The screen/armour must be earthed at both ends by connecting it to both the motor frame and the drive in 360° termination's. Ideally these will be via the glanded cable entry to the motor and drive.

Screening of all the control and signal cables is required to comply with the most stringent radiated emission limits of EN55011 Class B (including any optional tacho, encoders or communications connections etc.). The screen integrity should be continuous right back to the drive. Always minimise the length of screen stripped back to make this connection. **The screen should only be connected at the drive end.** If high frequency noise is still a problem, earth at the non drive end via a 0.1µF capacitor.

Cubicle Mount (582/583)

The cable between the cubicle and the motor must be screened or armoured. The screen/armour must be earthed at both ends by connecting it to both the motor frame and the entrance to the cubicle, ideally in 360° termination's via cable glands. Often the screens are terminated on a power screen rail at the entrance to the cubicle using 'U' clips to achieve a near 360° screen bond.

EARTHING

Wall Mount (582/5831)

A single point earthing policy is to be followed as shown in figure D. The motor protective earth (PE) connection must run inside the screened cable between the drive and motor. This must be connected at one end to the motor protective earth terminal and at the other to the drive protective earth terminal in the cable gland box (Note, only one protective earth conductor is permitted at each earth terminal contacting point). The filter should be **permanently earthed**. Local regulations may dictate the motor protective earth connection is connected locally. This should be in addition to the protective earth connection made back to the drive module. The RF impedance of the local motor earth connection will be significantly greater than that via the screen/armour and will not introduce RF problems.

Safety earthing always takes precedence over EMC earthing.

Figure D EMC and Safety Earthing Policy

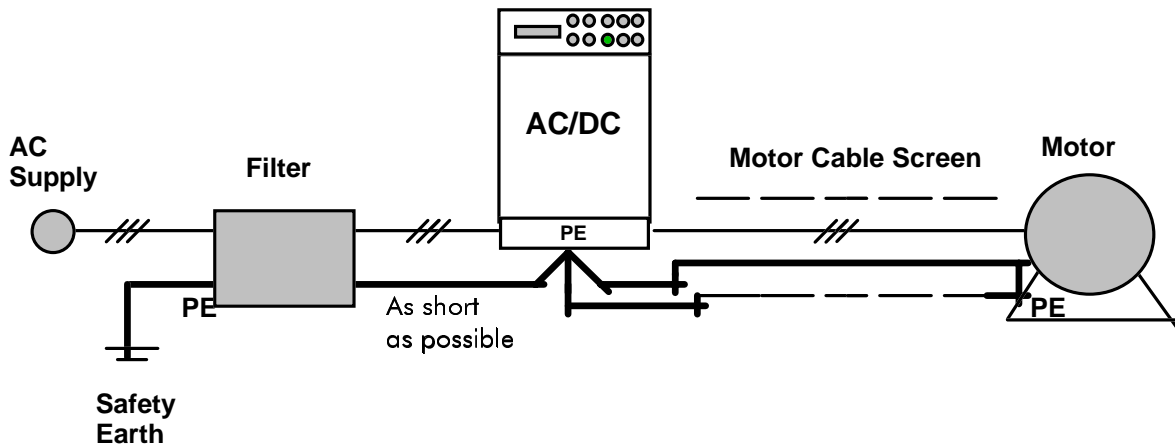

Cubicle Mount (582/583)

Reference should be made to EN60204 regarding earthing for cubicles. In addition, when more than one electrical product is fitted inside a cubicle care must be taken to ensure that noise flowing in the earth connection does not couple into other equipment. A star point earthing policy is strongly recommended separating noisy from quiet earths. Six earths can be identified as shown in figure E. The screens are terminated on the separate screen rails at the entrance to the cubicle using ‘U’ clips to achieve a near 360° screen bond.

Safety earthing always takes precedence over EMC earthing.

Refer to the separate Eurotherm Application manual entitled ‘EMC Installation Guidelines for modules and systems’, part number HA388879 for more information

Figure E: Cubicle Earthing Policy

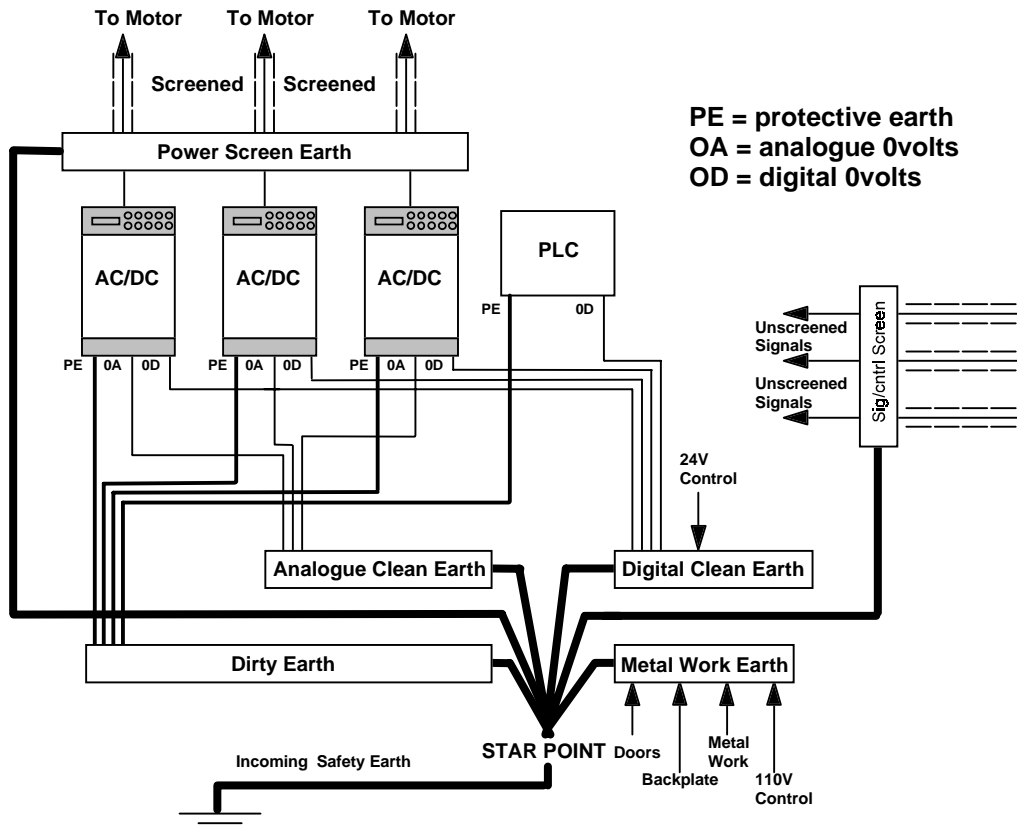

EMC TECHNICAL SPECIFICATION

Table H Minimum EMC Immunity Performance when installed as recommended

Port	Phenomenon	Test Standard	Level	Criterion	Generic Standard
Enclosure Port	ESD RF Field(Q1/96)	IEC 801-2*	8kV AD	Self Recovery	EN50082-1 (1992), Draft prEN50082-2 (1992)
		IEC 801-3	10V/m, 1kHz AM	No Change	
Power Ports	Fast Transient Burst	IEC 801-4	2kV	Self Recovery	
Signal & Control	Fast Transient Burst	IEC 801-4	2kV	Self Recovery	
Power Interfaces	Fast Transient Burst	IEC 801-4	2kV	Self Recovery	

* Only for wall mount product

Table I Maximum Emission Performance for 'CE' marked product with specified filters installed as recommended

Port	Phenomenon	Test Standard	Level	Generic Standard
Enclosure Port	Radiated	EN55011	Class B	EN50081-1 (1992)
Power Port	Conducted	EN55011	Class B*	EN50081-2 (1994)

* Achieved with up to 5m of motor cable.

The AC supply filters may be flash tested in circuit upto 2000V DC for 1 minute. Ensure all AC/DC drives and other equipment that may be damaged by such flash testing has been suitably isolated/removed/short circuited as applicable. Due to the internal capacitors between phase and earth, the DC voltage should be wound up slowly, to prevent excessive earth current. For similar reasons AC flash testing cannot be performed due to the excessive earth leakage current. Repeated flash testing on such units is not recommended as it may degrade the insulation.

EC Declaration of Conformity for EMC**EC DECLARATION OF CONFORMITY**

In accordance with the EEC Directive 89/336/EEC,
Article 10 and Annex 1, (EMC DIRECTIVE)

We Eurotherm Drives Ltd, address as below, declare under our sole responsibility that the
following electronic products

582, 583 & 5831

when installed, used and CE marked in accordance with the instructions in the product manual
(provided with each piece of equipment) using the specified EMC filters to which this
declaration refers is in conformity with the following standards:-

BSEN50081-1 (1992), BS EN50081-2 (1994)

BSEN50082-1 (1992) & draft prEN50082-2* (1992)

Following provisions of EEC-Directive
89/336/EEC with amendments 92/31/EEC and 93/68/EEC

8th December 1995

.....
Dr Martin Payn,
Conformance Officer
Eurotherm Drives Ltd

.....
Dr Dan Slattery,
Technical Director
Eurotherm Drives Ltd

.....
Date

* For information only

EUROTHERM DRIVES LIMITED

NEW COURTWICK LANE, LITTLEHAMPTON, WEST SUSSEX BN17 7PD

TELEPHONE: 01903 721311 FAX: 01903 723938

Registered number: 1159876 England. Registered Office: Leonardslee, Lower Beeding, Horsham, West Sussex RH13 6PP

Manufacturers EMC Declaration



MANUFACTURERS EMC DECLARATION

In accordance with the EEC Directive 89/336/EEC,
Article 10 and Annex 1, (EMC DIRECTIVE)
We Eurotherm Drives Ltd, address as below, declare under our sole responsibility that the
following electronic products

582, 583 & 5831

when installed and used in accordance with the instructions in the
product manual (provided with each piece of equipment) and using the
specified EMC filters to which this declaration refers is in conformity
with the following standards:-

BSEN50081-1 (1992), BSEN50081-2 (1994)
BSEN50082-1# (1992) & draft prEN50082-2# (1992)

29th April 1996

.....
Dr Martin Payn,
Conformance Officer
Eurotherm Drives Ltd

.....
Dr Dan Slattery,
Technical Director
Eurotherm Drives Ltd

.....
Date

Compliant with these immunity standards without specified EMC filters

EUROTHERM DRIVES LIMITED

NEW COURTWICK LANE, LITTLEHAMPTON, WEST SUSSEX BN17 7PD

TELEPHONE: 01903 721311 FAX: 01903 723938

Registered number: 1159876 England. Registered Office: Leonardslee, Lower Beeding, Horsham, West Sussex RH13 6PP