

MiniCon

*Microprocessor Controlled
IGBT Drive
Inverter Motor Speed Regulator
Operating Manual*

MiniCon Series	220V	0.2 ~ 0.75 KW (0.53 ~ 1.6 KVA)
---------------------------	-------------	---

Operating Manual

Table of Contents

Foreword	1
Chapter 1 Safety Precautions	
1. Precautions of operation	3
2. Precautions of operation environment.....	6
Chapter 2 Hardware Instruction and Installation	
1. Operation Environment.....	7
2. Model No. Instructions.....	8
3. Specifications	9
4. Wiring	14
5. Dimensions & Location of terminal block	17
Chapter 3 Software Index	
1. Control Panel Instructions	21
2. List of Parameters	22
3. Parameter Function Description.....	23
4. Malfunction Indication and Countermeasure	33
5. General Malfunction Examination Method	36
Chapter 4 Maintenance and Peripherals	

1. Foreword

To fully employ all functions of the inverter, and to ensure the safety of users, please read through this operating manual in detail. Should you have any further query, please feel free to contact your local distributor or sales person of Teco Electric. Our technical staff will be glad to help you.

※ Precaution

Inverter is a power electronic device, for safety reason, please take special care for paragraphs with “WARNING” or “CAUTION” symbol. They are important safety precautions to be aware of while transporting, installation, operating or examining the inverter. Please following these precaution to ensure your safety.

 WARNING
--

Personnel injury may be resulted by improper operation.

 CAUTION
--

The inverter or mechanical system may be damaged by improper operation.

 WARNING
--

- Do not touch the PCB or components on the PCB right after turning off the power before the charging indicator went off.
- Do not attempt to wire circuitry while power is on. Do not attempt to examine the components and signals on the PCB while the inverter operating.
- Do not attempt to disassemble or modify internal circuitry, wiring, or components of the inverter.
- The grounding terminal of the inverter must be grounded properly with 200V class type III standard.

 CAUTION
--

- Do not attempt to proceed dielectric strength test to internal components of the inverter. There are sensitive semiconductor-devices vulnerable to high voltage in the inverter.
- Do not connect the output terminals: T1(U), T2(V), and T3(W) to AC power outlet.
- The CMOS IC on the primary PCB of the inverter is vulnerable to static electrical charges. Do not contact the primary PCB of the inverter.

2. Examination before installation

Every Teco inverter has been fully tested and examined before shipment. Please carry out following examination procedures after unpacking your inverter.

- Check to see the model number of the inverter. It should be the one that you ordered.
- Check to see if there is any damage during the transportation. Do not connect the inverter to the power supply if there is any sign of damage.

Report to regional sale representative if you find any abnormal condition as mentioned above.

Chapter 1 : Safety Precaution

1. Precautions of operation

Before turning ON power

CAUTION

Choose appropriate power source with correct voltage setting as the input voltage specification of the inverter.

WARNING

Special care must be taken while wiring the primary circuitry panel. The L1 and L2 terminal must be connected to input power source and must not be mistakenly connected to T1, T2 or T3 terminal. This may damage the inverter when the power is turned on.

CAUTION

- Do not attempt to transport the inverter by the front cover. Securely hold the inverter by the heat-sink mounting chassis to prevent the inverter from falling that may cause personnel injury or damage the inverter.
- Install the inverter onto firm metal base or other inflammable material. Do not install the inverter onto or nearby any flammable material to avoid fire.
- Additional cooling fan should be installed if several inverter are installed into one control panel to lower the temperature inside below 40°C to avoid overheating or fire alarm.
- Turn off power supply before proceeding removal or installation of operating panel. Carry out installation procedure according to instructions given to avoid poor-contact situation resulting operating panel malfunction or no displaying information.
- Suitable for use on a circuit capable of delivering not more than 5000RMS symmetrical amperes.240V maximum
- Not proved with over speed Protection or equivalent
- Only intended for use in a pollution degree 2 macro environment or equivalent

When power turned ON

WARNING

Do not attempt to install or remove connector of inverter when the power supply is turned on. Otherwise, the inverter may be damaged due to the surge peak caused by the insertion or removal.

Under Operation

WARNING

Do not switch ON or OFF motor at the middle of operation. Otherwise, the inverter over-current break-down may be resulted.

WARNING

- Do not remove the front cover of the inverter when the power is ON to avoid personnel injury caused by electrical shock.
- When the automatic restart function is enabled, the motor machinery will be restarted automatically after fully stop from operation. Do not get close to the machinery to avoid personnel injury.

CAUTION

- Do not touch the heat-sink base.
- The inverter can be easily operated from low-speed to high-speed range. Please reconfirm the operating range of motor and machinery.
- Do not examining the signals on the PCB of the inverter when it is under operation.
- All inverter had been properly adjusted before delivery. Do not attempt to adjust it.

CAUTION

Do not proceed with disassemble or examination procedure before ensuring that the power is off and the Power LED extinguished.

When examination and maintenance

⚠ CAUTION

Inverter environment should be within temp: $-10^{\circ}\text{C} \sim +40^{\circ}\text{C}$, humidity under 95% RH without condensing.

⚠ CAUTION

After the removal of shield sticker, the environment temperature should be within $-10^{\circ}\text{C} \sim +50^{\circ}\text{C}$ and humidity under 95% RH without condensing. Besides, the inverter should be free from water dripping or metal dust.

2. Precautions of operation environment

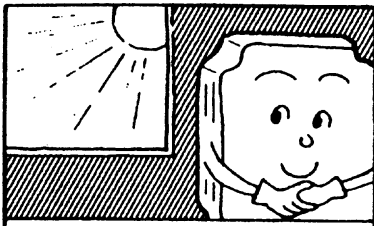

Avoid direct sunlight

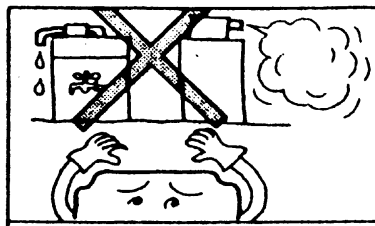

Away from corrosive gas or liquid

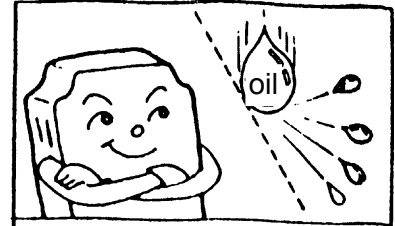

Away from oil grease and gas

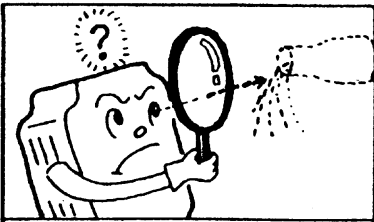

Away from salty environment

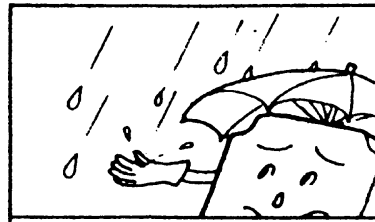

Avoid where rain or dripping water may get into the inverter

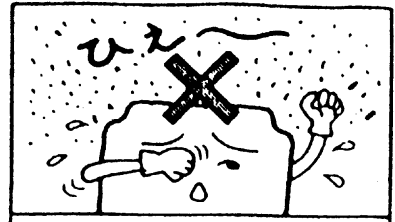

Avoid metal dust and dusty environment

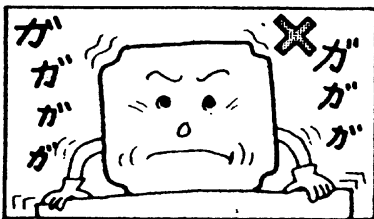

Avoid massive vibration

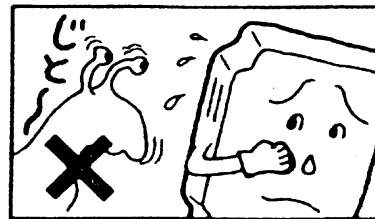

Avoid heat

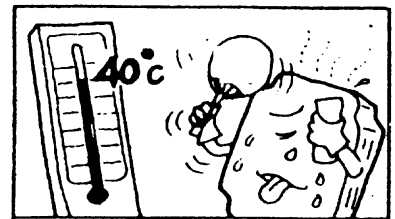

Avoid where environment temperature is too high

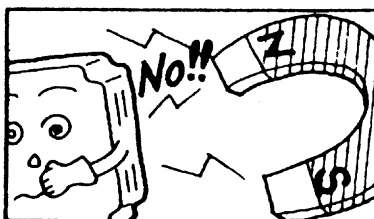

Away from high electrical-magnetic wave or ultra-high wave.
(such as electro-soldering machine or other similar machinery.)

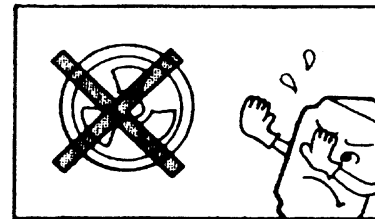

Away from radio-active matter

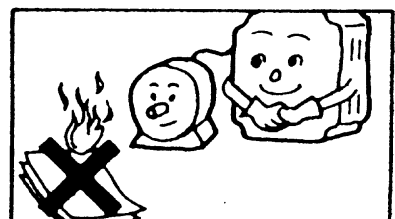

Away from flammable material

Chapter 2 : Hardware Instruction and Installation

1. Operation Environment

The installation site of the inverter pose direct impact to the fully functionality and the life-span of your inverter. Please carefully choose the installation site to meet following requirements:

- Mount the unit vertically
- Environment temperature: $-10^{\circ}\text{C} \sim +40^{\circ}\text{C}$
without shield sticker : $-10^{\circ}\text{C} \sim +50^{\circ}\text{C}$
- Avoid placing close to any heating equipment
- Avoid water dripping or humid environment
- Avoid direct sunlight
- Avoid oil or salty corrosive gas
- Avoid contacting corrosive liquid or gas
- Prevent foreign dusts, flocks, or metal scraps from entering interior
- Away from radioactive matter or flammable material
- Avoid electric-magnetic interference (soldering or power machinery)
- Avoid vibration, if vibration can not be avoided, anti-rattler should be installed to reduce vibration
- If inverter is installed in control panel, please tear off shield sticker of MiniCon .Additional cooling fan should be installed to lower the environment below 50°C

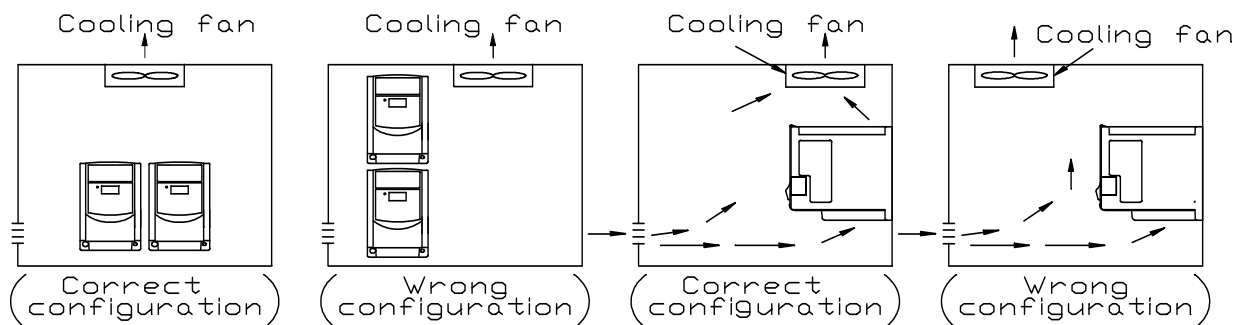

- Installation of the inverter must place the front side of inverter facing front and the top of inverter towards up direction for better heat dissipation.
- Installation rooming must be compliant to following requirement.

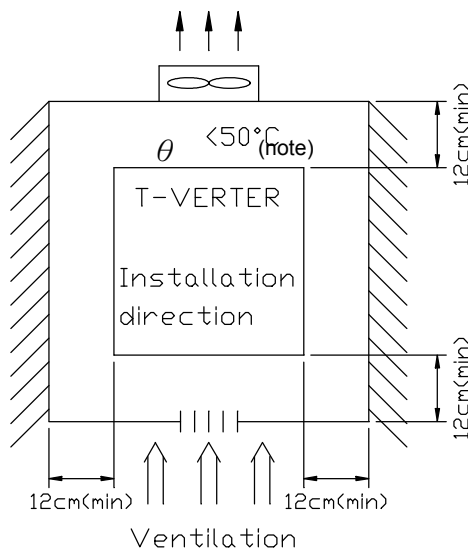

(a) Front view

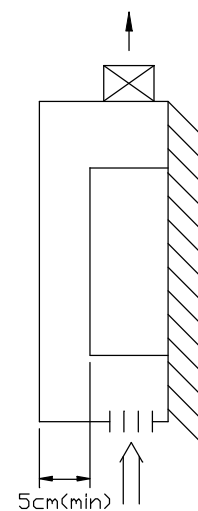

(b) Side view

note : please tear off shield sticker of MiniCon

θ : maximum temperature in the enclosure in $^{\circ}\text{C}$

2. Model No. Instructions

Inverter Model \Downarrow MODEL: E2-201-M1F

Input Power Rating \Downarrow I/P: AC 1PH 200 ~ 240V 50/60 Hz

Output Rating \Downarrow O/P: AC 3PH 0 ~ 240V 1.6KVA 4.2A

MiniCon	-	2	01	-	M	1	F
Series		Power Voltage	Horse Power Rated		Chassis Configuration	Power Supply	Filter Option
		2:200V	P2:1/4 Hp P5:1/2 Hp 01: 1 Hp		M: Standard Model	1: Single Phase	F: With filter Blank : without filter

MiniCon product specification

Model No: MiniCon		2P2-M1 F	2P5-M1F	201-M1F	2P2-M1	2P5-M1	201-M1
Suitable Motor Power Rating (KW)		0.2	0.4	0.75	0.2	0.4	0.75
Rated	Motor HP	1/4	1/2	1	1/4	1/2	1
	Current A	1.4	2.3	4.2	1.4	2.3	4.2
	Capacity KVA	0.53	0.88	1.6	0.53	0.88	1.6
	Weight (Kg)	0.76	0.77	0.8	0.68	0.69	0.72
Input Voltage Max.		Single phase 200-240V (+10%-15%) , 50/60Hz (+/-5%)					
Output Voltage Max.		Three phase 200-240V +10%-15% (Input Voltage Max)					
Input Signal Type		PNP type (SOURCE) input					
Control Method		Sinusoidal wave PWM control					
Freq. Control	Freq. Range	0~120 Hz					
	Resolution Setting	Digital : 0.1 Hz(0~99.9Hz); 1Hz(100~120Hz) Analog:0.06Hz/60Hz					
	Keyboard Setting	Directly setup by ▲▼ buttons.					
	External Signal Setting	0~10V, 4~20mA , 0~20mA					
	Other function	Frequency upper and lower limit					
General Control	Accelerate/Decelerate time	0.1~ 999 Sec					
	V/F Pattern	6 Patterns					
	Torque control	Torque boost level adjustable (manual torque boost)					
	Multi-Function input	2 point, to be used as multi-speed 1(Sp1) / Jog / External emergency stop / External bb / Reset					
	Multi-Function output	1a Relay terminal, to be setup as Fault / Running / Frequency. agreed function					
	Braking Torque	About 20%, additional breaking resistance not allowed					
	Other function	Decelerate or free run stop, Auto reset, DC braking frequency / Voltage / Time can be setup by constants.					
Indication function		7 segments*3 indicate frequency / inverter parameter / fault record / program version.					
Operating temperature		-10 ~ 40°C					
Humidity		0~95% RH non-condensing.					
Vibration		Under 1 G (9.8 m/s ²)					
EMC specification		Class A (Filter build in)					
Protection level		IP20					
UL		UL508C					
Protection	Overload protection	150% for 1min.					
	Over-voltage	DC voltage > 410V					
	Under voltage	DC voltage < 200V					

function	Momentary power-loss	0 ~ 2 sec : MiniCon can be restart by speed search
	Stall Prevention	Accelerate / Decelerate / Constant speed
Protection function	Output terminal short-circuit	Electronic circuitry protection
	Grounding fault	Electronic Circuitry protection
	Other function	Heat sink protection , Current limit
Dimension		W*H*D = 72mm*132mm*118mm
Installation		Install by mounting screw or DIN rail (Option).

■ Suitable optional and Wiring Specification

Molded-Case Circuit Breaker / Magnetic Contact

- **Teco maintenance and service do not apply to damage caused by following situation:**

- (1) Damage to the inverter caused by the lack of appropriate molded-case circuit breaker or a circuit breaker with too-large capacity is installed in between the power supply and the inverter.
- (2) Damage to the inverter caused by the serial magnetic contact, phase advancing capacitor, or surge-protector in between the inverter and the motor.

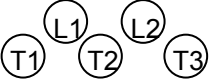
Model No: MiniCon	2P2 -M1F	2P5-M1F	201-M1F
Molded-case circuit breaker line Made by Taian Electric	TO-50E 15A	TO-50E 15A	TO-50E 20A
Magnetic Contact (MC)	Made by Taian Electric CN-11	Made by Taian Electric CN-11	Made by Taian Electric CN-11
Primary Circuit Terminal (TM1) 	Wire dimension 2.0mm ² Terminal screw M3	Wire dimension 2.0mm ² Terminal screw M3	Wire dimension 2.0mm ² Terminal screw M3
Signal Terminal (TM2) 1~11	Wire dimension 0.75mm ² (#18 AWG), Terminal screw M3		

- **Please utilize three-phase squirrel-cage induction motor with appropriate capacity.**
- **If a inverter is used to drive more than one motor, the total capacity must be smaller than the capacity of the inverter. Additional thermal relay must be installed in front of every motor. Use the Fn_18 at 1.0 times of the rated value specified on the motor nameplate at 50Hz, 1.1 times of the rated value specified on the motor nameplate at 60Hz.**
- **Do not install phase advancing capacitor, LC, or RC component between the inverter**

and the motor.

Application and precautions of Peripherals

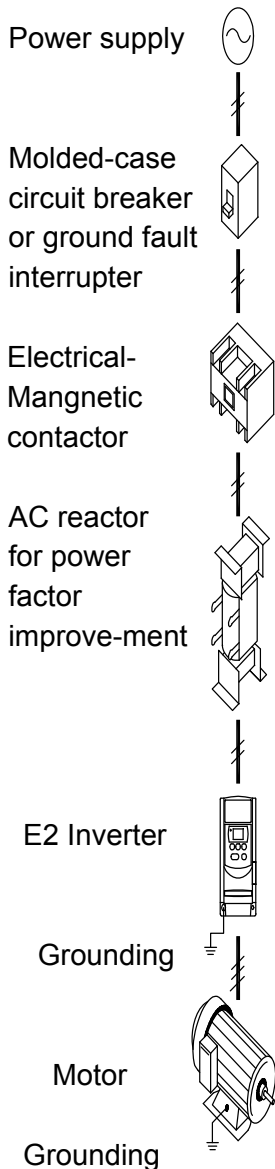

Power Source :

- Ensure to apply power source at correct rated voltage to prevent from damaging the inverter.
- Circuit breaker must be installed in between the AC power supply and the inverter.

Molded-case circuit breaker :

- Utilize appropriate circuit breaker suitable for the rated voltage and current ratings of the inverter to switch ON/OFF the power supply to the inverter and as a protection for the inverter.
- Do not operate the circuit breaker to switch ON or OFF the inverter.

Leakage circuit breaker :

- Leakage circuit breaker should be added to prevent false operation cause by leakage current and to ensure personnel safety.

Magnetic Contact :

- The Magnetic Contact can be omitted at ordinary operation. To utilize external control, automatic restart, or breaking controller the magnetic contact must be added at the primary side.
- Do not operate the magnetic contact to switch ON or OFF the inverter.

Power improvement AC Reactor :

- If large capacity power source is applied (over 600KVA), additional AC reactor may be added to improve power factor.

Inverter :

- Power supply input terminals L1 and L2 is not differentiated on phase sequence, they can be arbitrarily connected. Their connection may be exchanged.
- Output terminal T1, T2, and T3 should be connected to the U, V, and W terminals of the motor respectively. If motor turns in opposite direction of the inverter, simply exchanging two of three wire connection may correct this problem.
- Output terminal T1, T2, and T3 must not be connected to power source to prevent from damaging inverter.
- Grounding terminal Properly ground the grounding terminal in compliance to 200V class type three grounding

External wiring should be carried out in accordance with following requirement. Check and reassure the wiring is correct after the wiring is complete. (Do not utilize the control circuitry buzzer to check the wiring.)

EMI connecting:

It is very important that the connections between the frequency inverter with the screened motor cable and the EMI filter during the EMI tests are as following.

- Use a metal grounding plate and place the frequency inverter and the EMI filter on the plate.
- Use a screened motor cable with 4 connectors (U,V,W,& Earth), don't use the shielding as safety earth (shield is high frequency earth)
- Remove painting around the two metal coupling nut holes. So that the metal coupling nuts (and the shielding) make contact with the frequency inverter and the motor.
- Don't solder a conductor to the shielding (pig tail)
- Use a metal clamp to connect the shielding from the motor cable with the metal grounding plate. Now there is a perfect high frequency earth connection between frequency inverter . grounding plate and EMI filter.
- Keep the distance between frequency inverter and EMI filter as short as possible (< 30cm) otherwise use screened cable with a metal coupling nut and a metal clamp addle to connect the shielded cable to the frequency inverter and metal grounding plate.
- The only earth connection between the LISN and the test plate should be via the EMI filter.
- Use a motor which belongs to the power rate of the frequency inverter . otherwise use a motor of less power.
- Install a noise filter for inverter onto the output side of the primary circuitry can suppress conducting noise. To reduce radio active noise, a metal pipe should be apply for wiring, and the wiring should be away from other controlling machine for more than 30 cm.

Class B

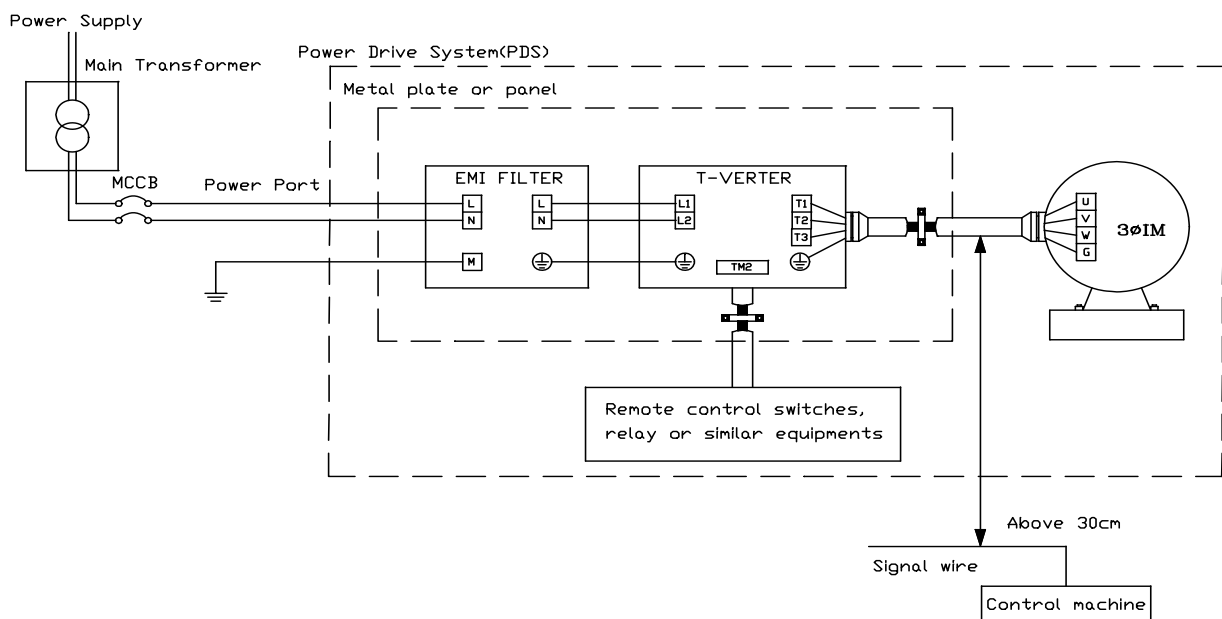

Class A

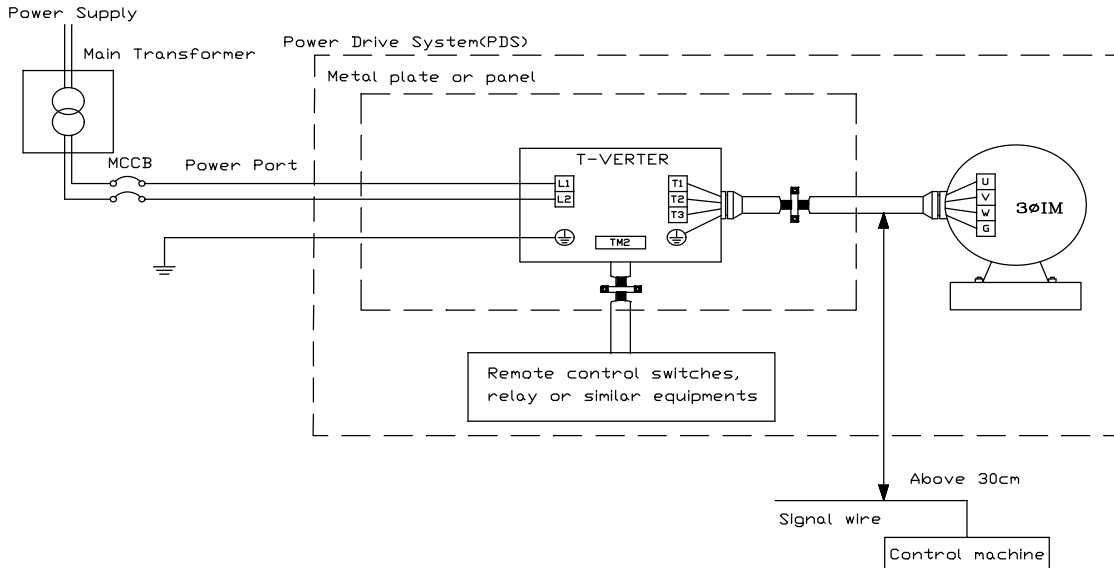

- When the distance between the inverter and motor is longer than 100m, connection wire should be carefully chosen to reduce the wiring resistance below 3% and the voltage drop $(V) = \sqrt{3} \times \text{Wire resistance } (\Omega/\text{km}) \times \text{wire length (m)} \times \text{current} \times 10^{-3}$

(B) Control circuitry wiring must be separated and away from the primary circuitry control line and other high-voltage or large-current power lines to avoid noise interference.

- To reduce the noise interference and avoid mistake operation, shielded twisted pair cable must be used to wire the control circuitry. Please refer to following diagram. Connect the shielding wire onto the grounding terminal.

Wiring distance must be under 50m.

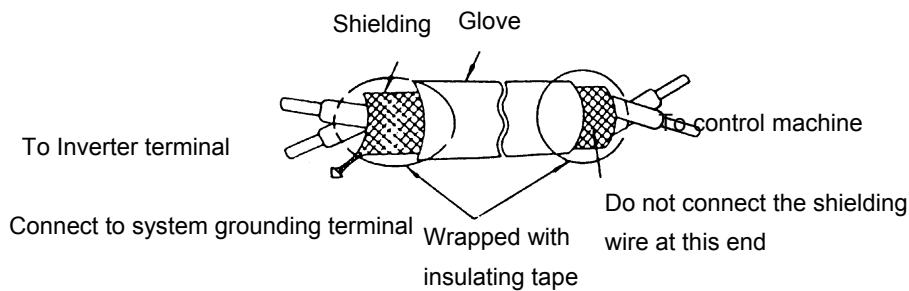

(C) The grounding terminal of the inverter must be correctly grounded in compliance with 200V class type three grounding.

- Grounding wire should be wired in accordance to electrical equipment (AWG) with the length of the grounding wire as short as possible.

- Other connections(external 24V supply)

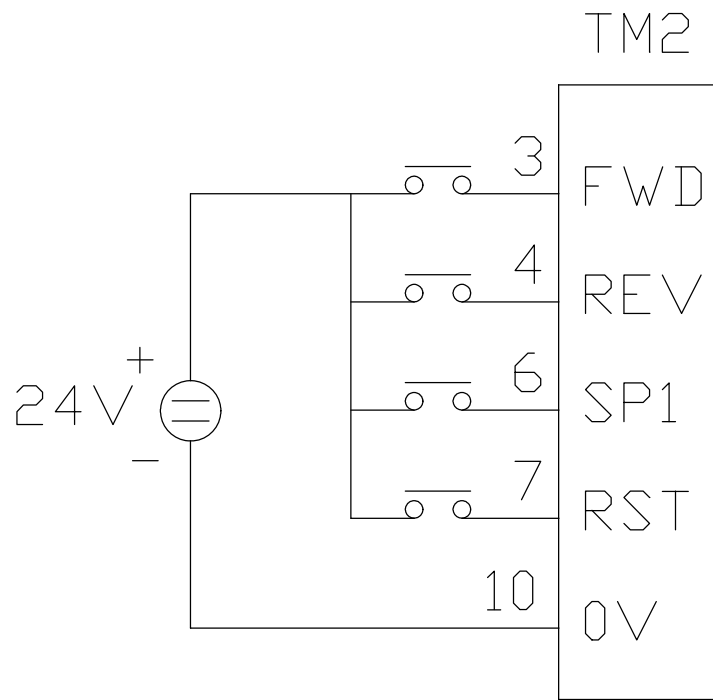

MiniCon series inverter terminal descriptions

Primary circuitry terminal block (TM1) descriptions

Terminal symbol	Function description
L1 (R)	Primary power source input
L2 (S)	
T1 (U)	Inverter output
T2 (V)	
T3 (W)	

* Tightening torque for TM1 is 1 LBS-FT or 12 LBS-IN.

* Use copper conductors only size field wiring based on 75 degrees C wire only.

* Wire voltage rating must be a minimum of 300V

* Electric ratings of the termination (TM1) as 300V 15A

MiniCon control circuitry terminal block (TM2) description

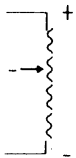
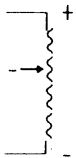
Terminal symbol		Terminal function description	
1	TRIP	Fault relay output terminal	
2	RELAY	Connection point rated capacity 250VAC/1A (30VDC / 1A)	
3	FWD	Operation control terminals (refer to Fn_03)	
4	REV		
5	+ 12V	Common point of terminal 3 / 4 / 6 / 7	
6	SP1	Multifunction input terminals (refer to Fn_19)	
7	RESET		
8		+10V	Power terminal of potentiometer (Pin 3)
9		Analog input point	Analog frequency signal input terminal (Pin 2 of potentiometer or positive terminal of 0~10V / 4~20mA / 0~20mA)
10	0V (FM -)	Analog common point	Analog signal common point (Pin 1 of potentiometer or negative terminal of 0~10V / 4~20mA / 0~20mA)
11	FM+	Analog output positive connection point	Analog frequency signal output terminal Output terminal signal is 0 ~ 10VDC/Fn6

* Tightening torque for TM2 is 0.42 LBS-FT or 5.03 LBS-IN.

* Use copper conductors only size field wiring based on 75 degrees C wire only.

* Wire voltage rating must be a minimum of 300V

* Control wiring should not run in the same conduit or race way with power or motor wiring

* Single Input and Output Terminals (TM2) Ratings are ALL Class 2

SW1 function description

SWITCH 1	External signal type
	<p>0~20mA analog signal (When Fn11 set to 1)</p> <p>4~20mA analog signal (When Fn11 set to 2)</p>
	<p>0~10 VDC analog signal (When Fn11 set to 1)</p>

Dimensions & Location of terminal block

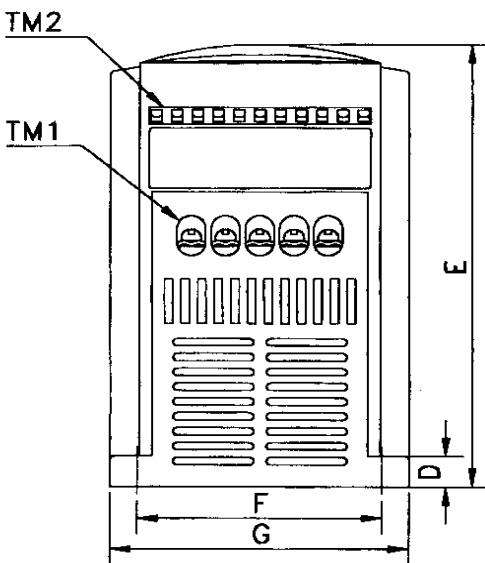
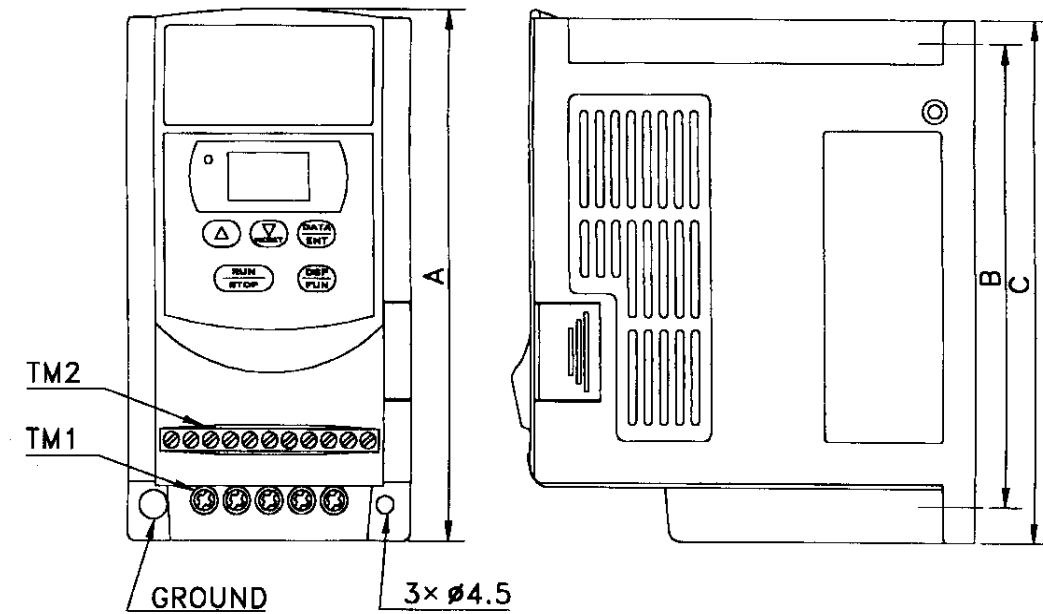

Unit : mm

LENGTH MODEL	A	B	C	D	E	F	G
E2-2P2/2P5/201	132	116	130	8.2	118	61	72

Dimensions & Installation of class B Filter(E2F-2102)

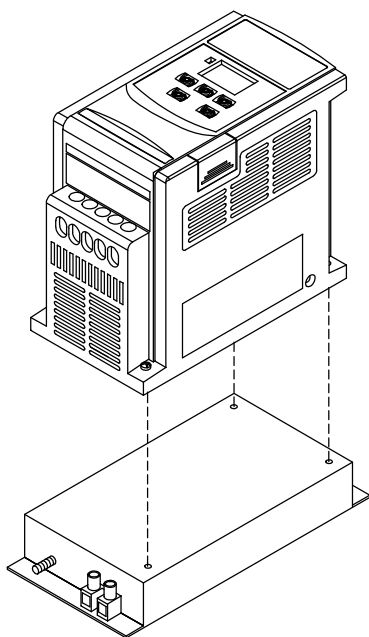
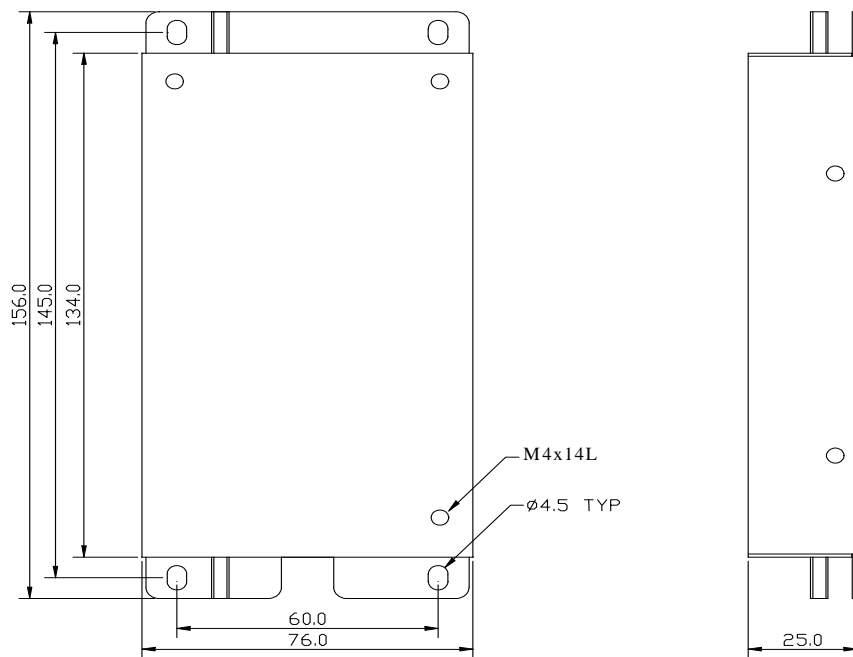

Inverter with class B filter (E2F-2102) mounted.

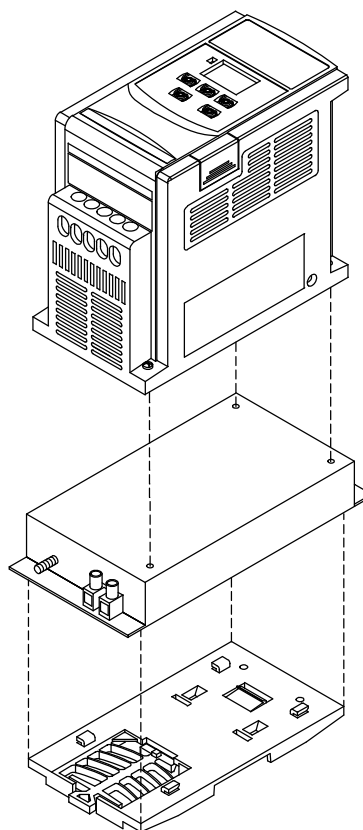

Inverter with class B filter (E2F-2102) & Din rail (DINE2-201) mounted.

Mounting screw operation diagram

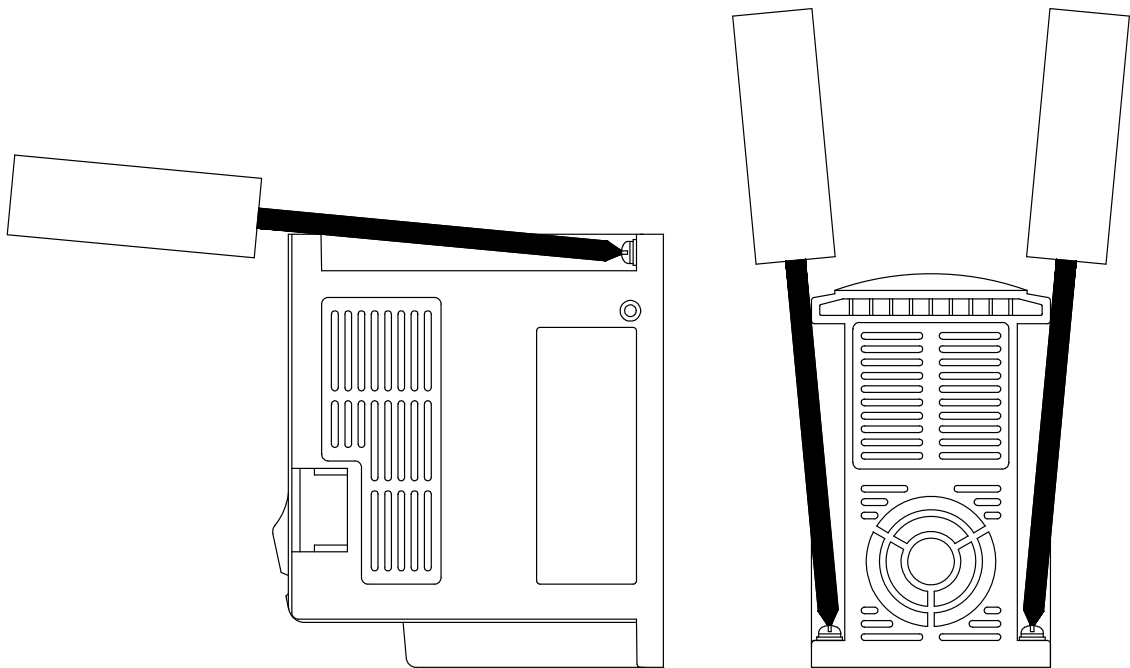

Din rail (DIN E2-201) operation diagram

Step1-
Aim and insert the 4 retention ribs of DIN E2-201 at the 4 holes in rear panel of MiniCon inverter

Step2-
Push the DIN E2-201 forward until the middle rib grips firmly with rear panel

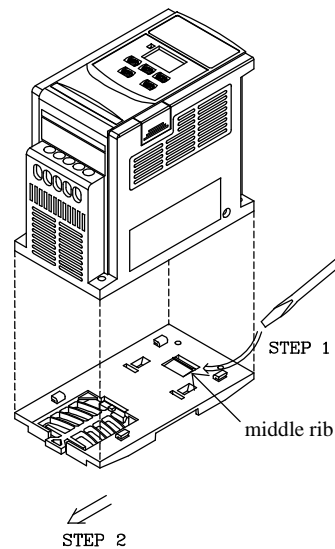
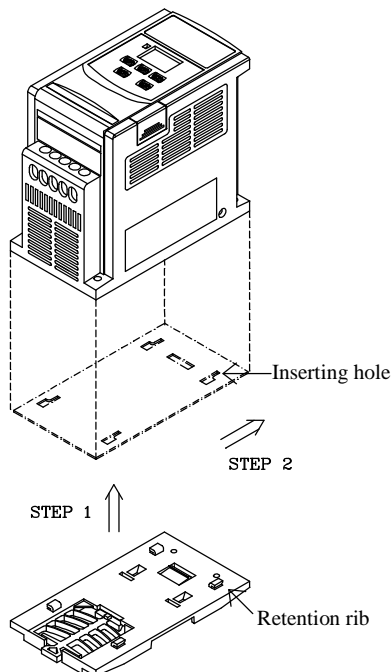

Step1-
Use small screw driver inserting the middle rib of DIN E2-201 and press the screw driver in order to strip DIN E2-201 from MiniCon inverter

DIN Rail Installation(rail)

Mounting clamp and 35mm width rail must be used to install MiniCon on the rail.

Install MiniCon

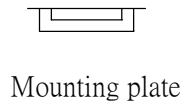
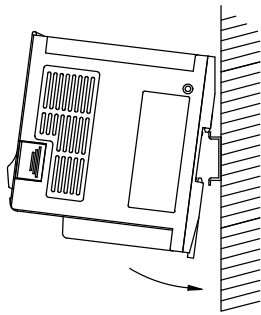

Dismounting MiniCon

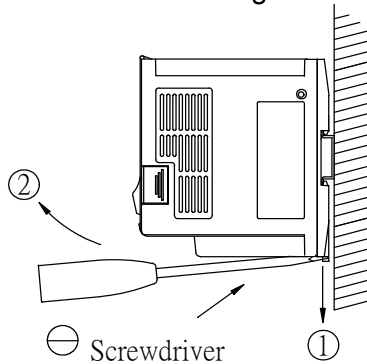

First place the groove on the back of module on the upper edge of din rail , and then push the module down to lock up position. Finally press the mounting plate upward into module.

- 1 Pull the mounting plate downward.
- 2 Rotate the MiniCon module to dismount it.

Mount

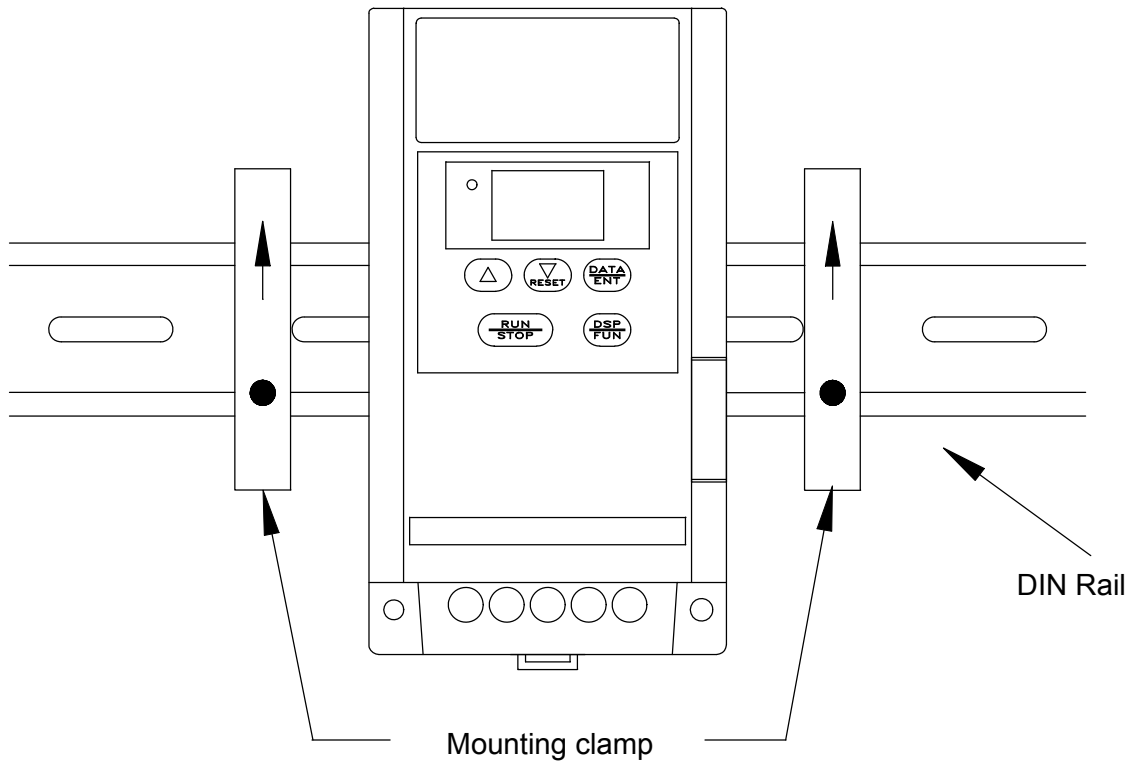

Mounting clamp must be used to fasten MiniCon

Chapter 3 : Software Index

Keypad indication and operating instructions

Keypad appearance and indication description

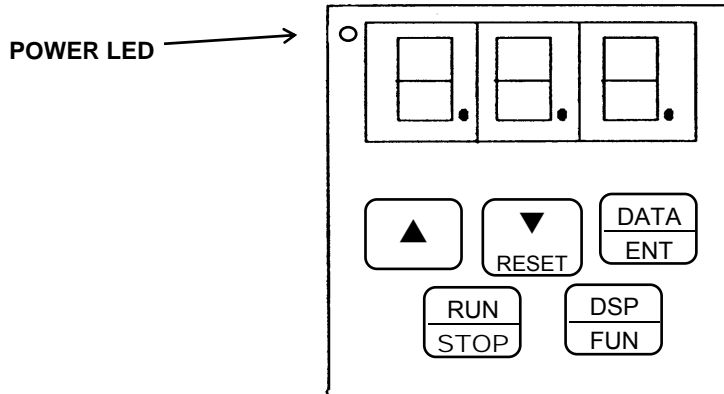

⚠ CAUTION

Do not operate keypad by screwdriver or other sharp-ended tool to avoid damaging keypad.

Brief keypad operation flowchart

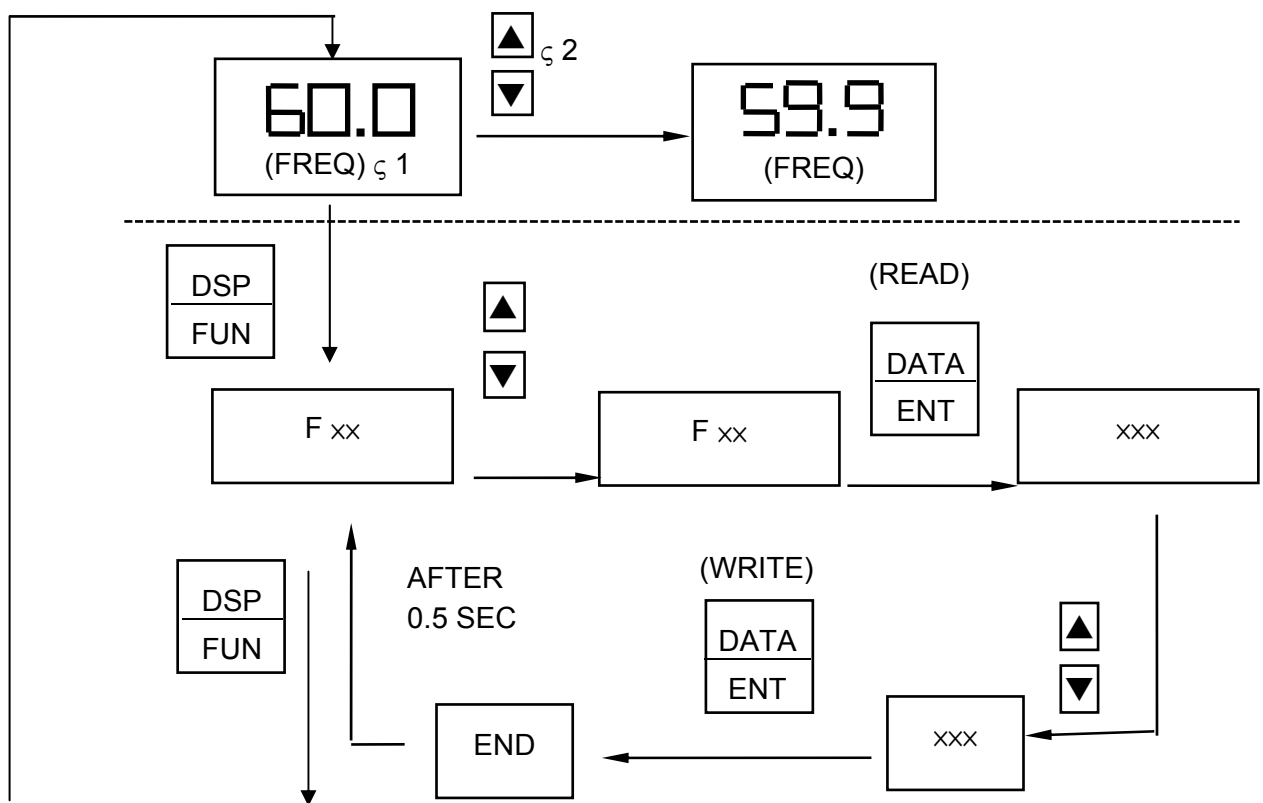

- ※1 : Displayed setting frequency when stopped. Display output frequency when running.
- ※2 : The setting frequency can be modified either when stopped or when running.

List of Parameter

Function	FN_	Function Description	Unit	Range	Factory setting	Note
	0	Factory Adjustment			0	
Accelerate / Decelerate Time	1	Accelerate time	0.1SEC	0.1 ~ 999 S	5.0	*1*3
	2	Decelerate time	0.1SEC	0.1 ~ 999 S	5.0	*1*3
Operation mode	3	0: Forward / Stop, Reverse / Stop 1:Run/Stop, Forward / Reverse	1	0 ~ 1	0	
Motor rotation direction	4	0: Forward 1: Reverse	1	0 ~ 1	0	*1
V/F Pattern	5	V/F pattern setting	1	1 ~ 6	1/4	*2
Frequency upper/lower limit	6	Frequency upper limit	0.1Hz	1.0 ~ 120Hz	50/60Hz	*2*3
	7	Frequency lower limit	0.1Hz	0.0 ~ 120Hz	0.0Hz	*3
SPI frequency	8	SP1 frequency	0.1Hz	1.0 ~ 120Hz	10Hz	*3
JOG frequency	9	JOG frequency	0.1Hz	1.0~ 10.0Hz	6Hz	
Operation control	10	0:keypad 1: external terminal	1	0 ~ 1	0	
Frequency Control	11	0:keypad 1:external terminal(0~10v/0~20mA) 2: external terminal (4~20mA)	1	0 ~ 2	0	
Carrier frequency control	12	Carrier Frequency setting	1	1 ~ 5	5	
Torque compensation	13	Torque compensation gain	0.1%	0.0 ~ 10.0%	0.0%	*1
Stop method	14	0:decelerate stop 1:free run stop	1	0 ~ 1	0	
DC braking setting	15	DC braking time	0.1S	0.0 ~ 25.5S	0.5S	
	16	DC braking injection frequency	0.1Hz	1 ~ 10Hz	1.5Hz	
	17	DC braking level	0.1%	0.0 ~ 20.0%	8.0%	
Electronic thermal	18	Protection base on motor rated current	1%	50 ~ 100%	100%	
Multifunction input connection point	19	Multifunction input terminal 1 function	1: Jog 2: Sp1 3: Emergency stop 4: External Base Block 5. Reset		2	
	20	Multifunction input terminal 2 function			5	
Multi-function output	21	Multifunction output terminal	1: Operating 2: Frequency reached 3: Fault		3	
Reverse instruction	22	0: REV run enabled 1: REV run disabled	1	0 ~ 1	0	
Momentary power loss	23	0: enabled 1: disabled	1	0 ~ 1	0	
Auto restart	24	Number of Auto-restart times	1	0 ~ 5	0	
Function	FN_	Function Description				Note

Factory setting	25	010: Constants initialization to 50Hz system 020: Constants initialization to 60Hz system	*2
	26	Reserve	
	27	Reserve	
	28	Reserve	
Software version	29	CPU program version	
Fault trace	30	Last 3 malfunction memory	

NOTE:

*1: Indicate this parameter can be adjusted during running mode

*2: Please refer to Fn_25

*3: If the setting range is above 100 , the setting unit becomes 1.

Parameter function description

Fn_00 Factory adjustment parameter. Do not change.

Fn_01 : Accelerate time = 0.1 ~ 999 sec

Fn_02 : Decelerate time = 0.1 ~ 999 sec

1. Accelerate/decelerate time calculation formula:

$$\text{Accelerate time} = \text{Fn_01} \times \frac{\text{Setting Frequency}}{60 \text{ Hz}}$$

$$\text{Decelerate time} = \text{Fn_02} \times \frac{\text{Setting Frequency}}{60\text{Hz}}$$

Fn_03 : Operation mode selection =
 0 : Forward / Stop , Reverse / Stop
 1 : Run / Stop , Forward / Reverse

NOTE 1: Fn_03 take effect only when Fn_10 = 1 (external operation control)

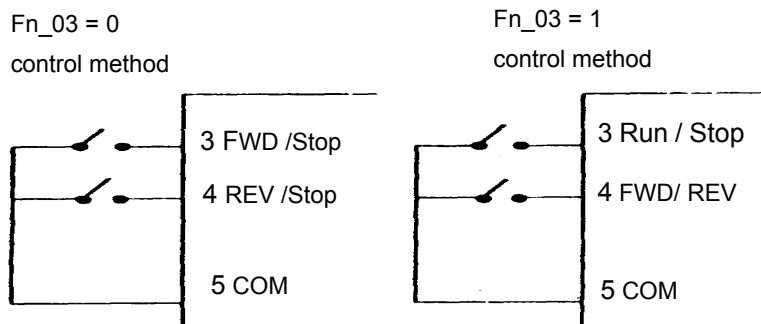

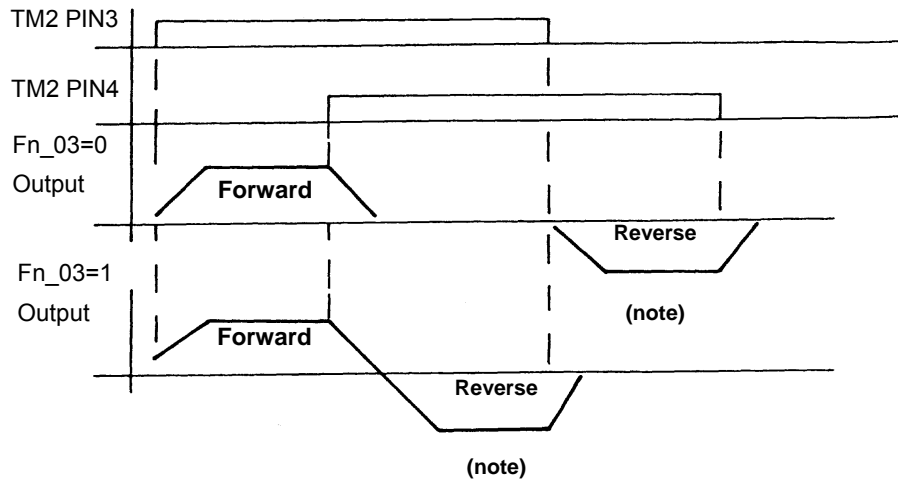

Note : Reverse command is ignored when Fn_22 = 1

Fn_04 : Motor rotation direction setting = 0 : forward
1 : reverse

Although there is no Forward/Reverse push button on the digital control panel, it is possible to adjust forward/reverse function by changing Fn_04 setting.

NOTE:

When Fn_22 =1: Reverse disabled, the Fn_04 can not be set to 1. Then keypad indication would display "LOC".

Fn_05 : V/F pattern setting = 1 ~ 6

Adjust Fn_05 = 1-6 to select one of six fixed V/F pattern. (refer to following tables)

Specification	50 Hz System		
Application	General Application	High starting torque	Decreasing torque
Fn_5	1	2	3
V/F pattern			
Specification	60Hz System		
Application	General Application	High starting torque	Decreasing torque
Fn_5	4	5	6
V/F pattern			

Fn_5	B	C
1/4	10%	8%
2/5	15%	10.5%
3/6	25%	7.7%

Fn_06 : frequency upper limit = 1 ~ 120 Hz

Fn_07 : frequency lower limit = 0 ~ 120 Hz

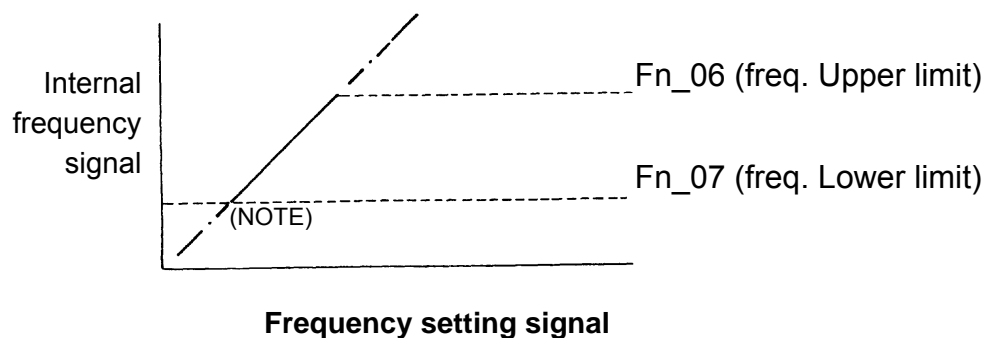

NOTE:

If $Fn_{07} = 0$ Hz, and the frequency instruction is equal to 0Hz, the inverter will stop at 0 speed.

If $Fn_{07} > 0$ Hz, and the frequency instruction $\leq Fn_{07}$, the inverter will output according to Fn_{07} setting.

Fn_08 : sp1 frequency = 1 ~ 120 Hz

Fn_09 : jog frequency = 1 ~ 10 Hz

1. When Fn_{19} or $Fn_{20} = 2$ and multifunction input terminal is ON, the inverter operate at sp1 frequency (Fn_{08})
2. When Fn_{19} or $Fn_{20} = 1$ and multifunction input terminal is ON, the inverter operate at jog frequency (Fn_{09})
3. The priority of reading frequency setting is : Jog \rightarrow Sp1 \rightarrow Keypad setting or external frequency signal

Fn_10 : Operation Control

= 0 : Operation instruction is setup by Keypad

= 1 : Operation instruction is setup by external terminal

NOTE:

When $Fn_{10}=1$ (external operation control), emergency stop on the keypad is enabled.

Fn_11 : Frequency control

= 0 : Frequency instruction is setup by Keypad

= 1 : Frequency instruction is setup by VR or analog signal on TM2 (0 ~ 10V / 0-20mA)

= 2 : Frequency instruction is setup by VR or analog signal on TM2 (4-20mA)

NOTE 1:

When Jog frequency or Sp1 frequency is switched on, the frequency is setup by Sp1 speed, the ▲ ▼ buttons on the keypad is disabled. Original setting will be restored after Sp1 connection is OFF.

NOTE2 :

During the acceleration after operating instruction and the acceleration/deceleration after Sp1 change the buttons on keypad is disabled.

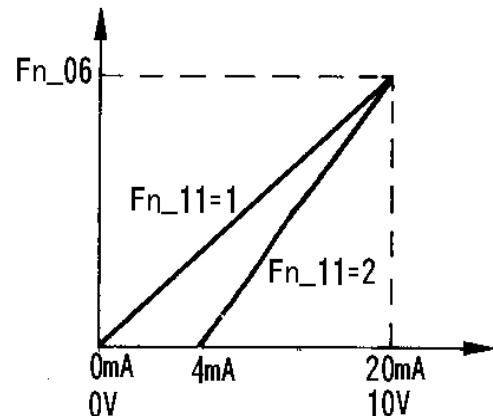

Fn_12 : carrier frequency = 1 ~ 5

Fn_12	carrier frequency	Fn_12	carrier frequency
1	4 kHz	4	7.2 kHz
2	5 kHz	5	8 kHz
3	6 kHz		

Although IGBT TYPE inverter can provide low noise environment under operation, it is possible that the slicing of high carrier frequency may interfere with external electronic components (or other controller) or even cause vibration driving motor. Adjusting carrier frequency can correct this situation.

Fn_13: Torque compensation gain = 0 ~ 10 %

Inverter output according to the B, C point voltage on the V/F pattern (refer to Fn_05 description) plus the Fn_13 settings to enhance the output torque

NOTE : When Fn_13 = 0, the torque boost function is disabled.

**Fn_14 Stopping method = 0 : decelerate stop
1 : free run stop**

Fn_15 DC braking time = 0 ~ 25.5 sec

Fn_16 DC braking starting frequency = 1 ~ 10 Hz

Fn_17 DC braking level = 0 ~ 20 %

If Fn_14 = 0

When the inverter receive the stop instruction, it decelerate to the frequency setup by Fn_16 and then output voltage level setup in the Fn_17; after the time duration setup in Fn_15, the inverter turn into complete stop.

If Fn_14 = 1

The inverter stop output immediately after receiving stop instruction. The motor get into free running state to completely stop.

Fn_18: Motor rated current = 50 ~ 100 %

1. Function of the electronic thermal protecting motor is as follow:

- (1) Motor rated current = Inverter rated current x Fn_18
Fn_18 = Motor rated current / inverter rated current
- (2) When the load is within 100% of the motor rated current, the operation continues. When the load reaches 150% of the motor rated current the operation may continues for only 1 minute. (refer to curve (1) in figures 3)
- (3) After protecting the electronic thermal activated, the inverter is cut off immediately. The OLI is flashing. To resume operation, push RESET button or activate external reset terminal.
- (4) When the motor is operating at low speed, the heat dissipation efficiency is lower down. The electronic thermal activation level is reduced also. (change from curve (1) to curve (2) in figure 3). Choose appropriate Fn_05 setting according to applied motor to reach a better protection.

2. Function of the electronic thermal protecting inverter is as follow:

- (1) When the load is within 103% of the inverter rated current, the operation continues. When the load reaches 150% of rated current of the inverter, operation may continue for only 1 minute. (refer to curve (1) of figure 3)
- (2) After the activation of the electronic thermal protecting inverter, the inverter is cut off immediately. The OL2 is flashing. To resume the operation, push RESET button or activate external reset terminal.

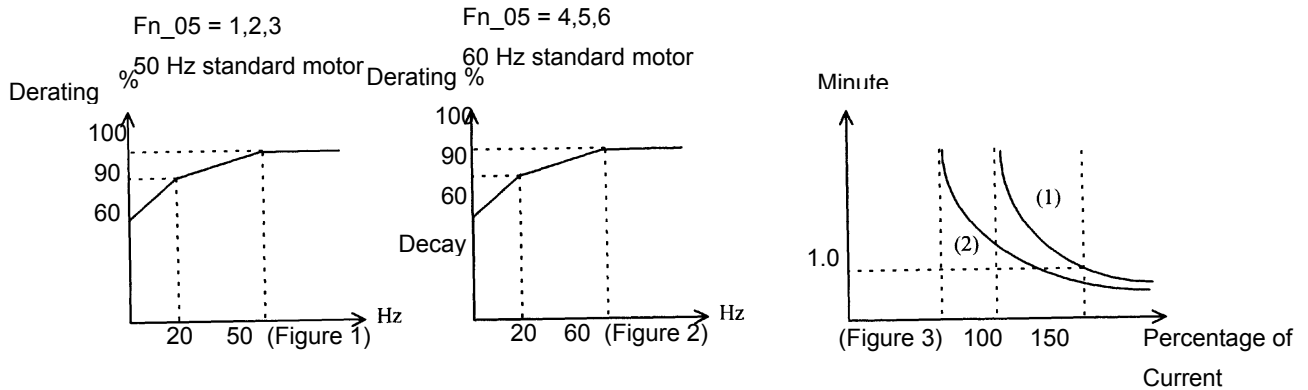

Fn_19: Multifunction input terminal 1 function = 1~5

Fn_20: Multifunction input terminal 2 function = 1~5

1. Fn_19, Fn_20 =1 : JOG

2. Fn_19, Fn_20 =2: Sp1 terminal

3. Fn_19, Fn_20 =3: External emergency stop signal

When the external emergency stop signal is activated, the inverter proceed a decelerate stop (ignoring setting in Fn_14). Flash E.S. after stop. After the emergency stop signal is deactivated, turn the RUN switch OFF and then ON again.(Fn_10 =1) Or, push the RUN key (Fn_10=0). The inverter will then resume operation and restart. If the emergency stop signal is removed before MiniCon stops, MiniCon will still execute emergency stop.

4. Fn_19, Fn_20 =4: External Base Block (immediate shut off)

When the external base block signal is activated, the inverter output will be immediately shut off (ignoring setting in Fn_14) and flash b.b. After the base block signal deactivated, turn the RUN switch OFF and then ON again (Fn_10 = 1) or push the RUN key (Fn_10=0), the inverter will restart from the starting frequency.

5. Fn_19, Fn_20 = 5: Reset when inverter fault.

Fn_21: Multi-function output terminal = 1 ~ 3

1. Fn_21 = 1: Run mode signal
2. Fn_22 = 2: Frequency agreed signal
3. Fn_21 = 3: Fault signal

Fn_22: Reverse instruction = 0 : REV command enabled
= 1 : REV command disabled

NOTE:

***When Fn_04 is set to 1 (reverse), Fn_22 can not be set to 1, indication displays "LOC".
Fn_04 must be change to 0 before setting Fn_22 to 1.***

Fn_23: Restart after momentary power loss
= 0 : restart enabled
= 1 : restart disabled

1. When AC power supply is temporary lower down below low voltage protection level because of power company or encountering large loading current in the same power supply system, the inverter will stop output immediately. If the power source resumes within 2 seconds, the inverter can restart by speed search (start tracing from the breaking frequency), otherwise the inverter break away from "LV-C".
2. When Fn_23 =0, if the transient power off duration is less than 2 sec., the inverter resume operation via speed search at 0.5 sec after power up. The restart times is not limited by Fn_24. If the transient power off duration is longer than 2 sec., it is up to the setting on the Fn_24 to decide if the inverter can be automatically restarted.
3. When Fn_23 = 1, the inverter break from operation immediately after the transient power off and indicate LV-C. It can not be restarted. (Not controlled by Fn_24)

Fn_24: Number of Auto-restart times = 0~5

1. When Fn_24 = 0, the inverter will not automatically rest after malfunction break from operation.
2. When Fn_24 > 0, the inverter will resume operation via SPEED SEARCH at 0.5 second after malfunction break and turn output from inertial operation to the operating frequency before break-up. After that, the inverter will accelerate or decelerate to current frequency setting.
3. When the inverter is set to deceleration or DC breaking, the transient restart procedure is not performed.
4. When either of following situation happen, the transient restart count will be reset:
 - (1) No additional malfunction (in operation or stop) occurs within 10 minutes.
 - (2) Press RESET button or external terminal RESET is ON.

Fn_25 : Factory settings function

= 010 : Constants initialization to 50Hz system

= 020 : Constants initialization to 60Hz system

1. When Fn_25 is set to 010, all parameters is restored to factory settings. The settings of Fn_05 =1 and Fn_06 = 50. Fn_25 is restored back to 000 after the reset process complete.
2. When Fn_25 is set to 020, all parameters is restored to factory settings. The settings of Fn_05 =4 and Fn_06 = 60. Fn_25 is restored back to 000 after the reset process complete.

Fn_26: Reserve

Fn_27: Reserve

Fn_28: Reserve

Fn_29: software (program) version

Fn_30: Fault trace

1. Fault trace : indicate the sequence of the occurrence of malfunctions by the location of decimal point. **x.xx** indicate a recently happened malfunction. **xx.x** indicate the last malfunction that happened. **xxx.** indicated the earliest malfunction in the record.
2. After entering the Fn_30 function, the **x.xx** record will be displayed first. After that, press▲ button can read out **xx.x** → **xxx.** → **x.xx** →,,, consecutively.
3. After entering Fn_30 function, if the RESET button is pressed, all three malfunction record will be cleared. Indication display **-.--**, **--.-**, and **---.**
4. When the content of malfunction memory indicate O.CC, indicate the latest malfunction code is OC-C and so on.

Malfunction Indication and Countermeasure

1. Manual reset inoperative malfunctions

INDICATION	CONTENT	POSSIBLE CAUSE	COUNTERMEASURE
CPF	Program error	Outside noise interference	Place a RC surge absorber in parallel with the noise generating magnetic contact
EPR	EEPROM error	EEPROM defective	Replace EEPROM
OV	Voltage too high while not operating	1.Power source voltage too high. 2.Detection circuitry defective	1.Examining the power supply 2.Return the inverter for repair
LV	Voltage too low while not operating	1.Power source voltage too low. 2.Detection circuitry defective.	1.Examining the power supply 2.Return the inverter for repair
OH	Inverter over heat while not operating	1.Detection circuit defective. 2.Environment over-heat or poor ventilation	1.Return the inverter for repair 2.Improve ventilation

2. Manual reset operative malfunctions (Auto-Reset inoperative)

INDICATION	CONTENT	POSSIBLE CAUSE	COUNTERMEASURE
OC	Over-current at stop condition	Detection circuit malfunction	Return the inverter for repair
OL1	Motor over-load	1. Loading too large 2. Improper V/F model setting 3. Improper Fn_18 setting	1. Increase capacity of motor 2. Adjust to use a proper V/F curve setting 3. Adjust Fn_18 according to instruction

INDICATION	CONTENT	POSSIBLE CAUSE	COUNTERMEASURE
OL2	Inverter over-load	<ol style="list-style-type: none"> 1. Loading too large 2. Improper V/F model setting 	<ol style="list-style-type: none"> 1. Increase capacity of inverter 2. Adjust to use a proper V/F curve setting

3. Manual Reset and Auto-Reset Operative Malfunction

INDICATION	CONTENT	POSSIBLE CAUSE	COUNTERMEASURE
OCS	Transient over-current starting machine	<ol style="list-style-type: none"> 1. Motor coil short-circuit with external casing 2. Motor connection wire short-circuit with grounding 3. Transistor module damaged 	<ol style="list-style-type: none"> 1. Examining motor 2. Examining wiring 3. Replace transistor module
OCA	Over-current at acceleration	<ol style="list-style-type: none"> 1. Acceleration time setting too short 2. Improper V/F feature selection 3. Applied motor capacity exceeds inverter capacity 	<ol style="list-style-type: none"> 1. Adjust acceleration time to longer setting 2. Adjust to a proper V/F curve 3. Replace and install another inverter with appropriate capacity
OCC	Over-current at steady speed	<ol style="list-style-type: none"> 1. Transient alteration of the loading 2. Transient alteration of the power supply 	<ol style="list-style-type: none"> 1. Examining the loading configuration 2. Install inductor on the power supply input side
OCd	Over-current at deceleration	Deceleration setting too short	Adjust to use a longer acceleration time
OCb	Over-current at braking	DC Braking frequency, braking voltage, or braking time setting too long	Adjust to reduce settings of Fn_15, Fn_16, or Fn_17
OVC	Over-voltage at operation/deceleration	<ol style="list-style-type: none"> 1. Deceleration time setting too short or inertial loading too large 2. Power supply voltage variation too large 	<ol style="list-style-type: none"> 1. Adjust to use a longer deceleration time 2. Install a inductor on the power supply input side 3. Increase the capacity of inverter

INDICATION	CONTENT	POSSIBLE CAUSE	COUNTERMEASURE
LVC	Insufficient voltage level at operation	1. Power supply voltage too low 2. Power supply voltage variation too large	1. Improve power source quality 2. Adjust to use a longer acceleration time 3. Increase capacity of inverter 4. Install a reactor on the power supply input side
OHC	Heat-sink over heated at operation	1. Loading too heavy 2. Ambient temperature too high or poor ventilation	1. Examining the loading 2. Increase capacity of inverter 3. Improve ventilation

Special Condition Description

INDICATION	CONTENT	DESCRIPTION
SP0	Zero Speed Stopping	When Fn_11 = 0, Fn_7= 0 and frequency setting < 1 Hz When Fn_11 = 1, Fn_7<(Fn_6/100), and frequency setting <(Fn_6/100)
SP2	Keypad emergency stop	The inverter setup to external operation (Fn_10=1). If the STOP key in the keypad is pressed at the middle of operation, the inverter stop according the setting in Fn_14 and flash SP2 after stop. The RUN switch must be turned OFF than ON to restart the machine.
E.S.	External emergency stop	When the external emergency stop signal is activated through the multi-function input terminal, the inverter decelerate and stop. Inverter flash E.S. after stop. (Refer to instruction for Fn_19 for detail).
b.b.	External BASE BLOCK	When the external BASE BLOCK signal is activated through the multifunction terminal, the inverter stop output immediately and flash b.b. for indication. (refer to instruction for Fn_19 for detail)

Keypad Operation Error Instruction

INDICATION	CONTENT	POSSIBLE CAUSE	COUNTERMEASURE
LOC	Motor direction locked	<ol style="list-style-type: none"> 1. Attempt to reverse direction when Fn_22 = 1 2. Attempt to set Fn_22 to 1 when Fn_04 = 1 	<ol style="list-style-type: none"> 1. Adjust Fn_22 to 0 2. Adjust Fn_04 to 0
Er1	Keypad operation error	<ol style="list-style-type: none"> 1. Press ▲ or ▼ keys when Fn_11=1 or under sp1 operation 2. Attempt to modify Fn_29 3. Attempt to modify parameter that is not allowed to be modified during operation (refer to parameter list) 	<ol style="list-style-type: none"> 1. Use ▲ or ▼ keys to adjust frequency setting only after Fn_11=0 2. Do not modify Fn_29 3. Modify in stop mode
Er2	Parameter setting error	1. Fn_6 ≤ Fn_7	1. Fn_6 > Fn_7

General Malfunction Examination Method

ABNORMALITY	CHECK POINT	COUNTERMEASURE
Motor inoperative	Is power source voltage delivered into L1, L2 terminal (is the charging indicator illuminated)?	<ul style="list-style-type: none"> • Check if the power source switched on. • Turn power source OFF and then ON again. • Reconfirm the power voltage level. • Check to see if the mounting screw secured.
	Is there voltage output from output terminal T1, T2 and T3?	<ul style="list-style-type: none"> • Turn power source OFF and then ON again.
	If the loading too heavy to block motor?	<ul style="list-style-type: none"> • Reduce load to start motor.
	Is there any abnormal condition of the inverter?	<ul style="list-style-type: none"> • Refer to malfunction handling instructions to examine and correct wiring.
	Is the forward or reverse instruction loaded?	

ABNORMALITY	CHECK POINT	COUNTERMEASURE
Motor inoperative	Is the analog frequency setting loaded?	<ul style="list-style-type: none"> • Check to see if wiring for analog frequency input signal is correct?
	If the operation mode setting correct?	<ul style="list-style-type: none"> • Check if the frequency input setting voltage is correct?
Motor operate in opposite direction	Is wiring on the output terminals T1, T2 and T3 correct?	<ul style="list-style-type: none"> • Operate by digital?
	Is the wiring for the forward and reverse signals correct?	<ul style="list-style-type: none"> • Wiring should be in accordance with the U, V, W terminals of motor.
Motor operation speed fixed	Is the wiring for analog frequency input correct?	<ul style="list-style-type: none"> • Examining the wiring and correct it.
	Is the operation mode setting correct?	<ul style="list-style-type: none"> • Examining the wiring and correct it.
	Is the loading too heavy?	<ul style="list-style-type: none"> • Operation panel operation mode setting check.
Motor operation at speed too high or too low	Is the specification of motor (poles, voltage) correct?	<ul style="list-style-type: none"> • Reduce loading
	Is the gear ratio correct?	<ul style="list-style-type: none"> • Reconfirm motor specification.
	Is the highest output frequency setting correct?	<ul style="list-style-type: none"> • Reconfirm gear ratio
	Is the voltage on motor side reduced extremely?	<ul style="list-style-type: none"> • Reconfirm highest output frequency
Abnormal speed variation at operation	Is the loading too heavy?	<ul style="list-style-type: none"> • Reduce loading variation
	Is the loading variation too large?	<ul style="list-style-type: none"> • Increase inverter and motor capacity
	Is the input power source steady and stable?	<ul style="list-style-type: none"> • Install AC reactor on the power supply input side

Simple MiniCon Troubleshooting Procedure

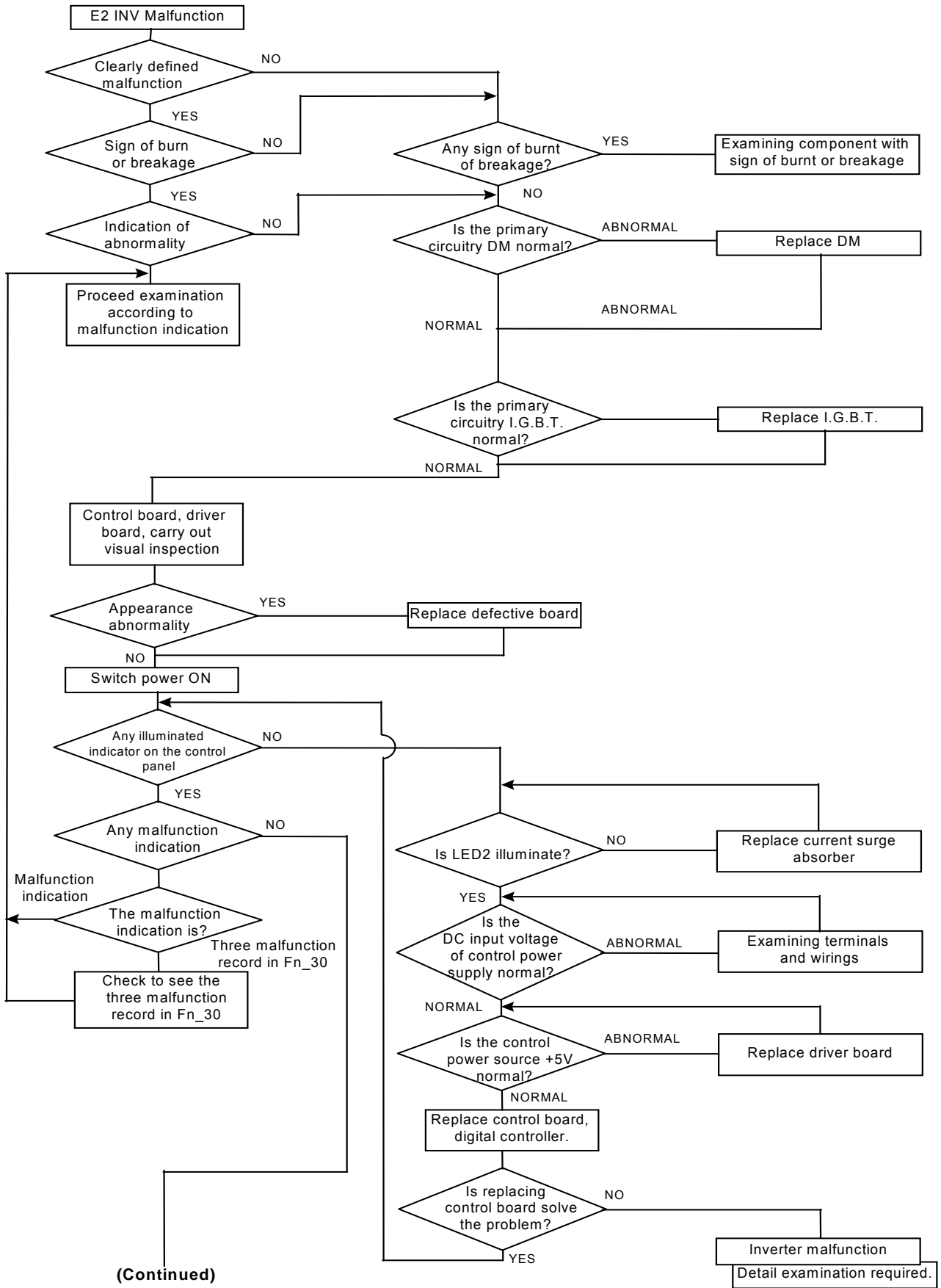

(Continued)

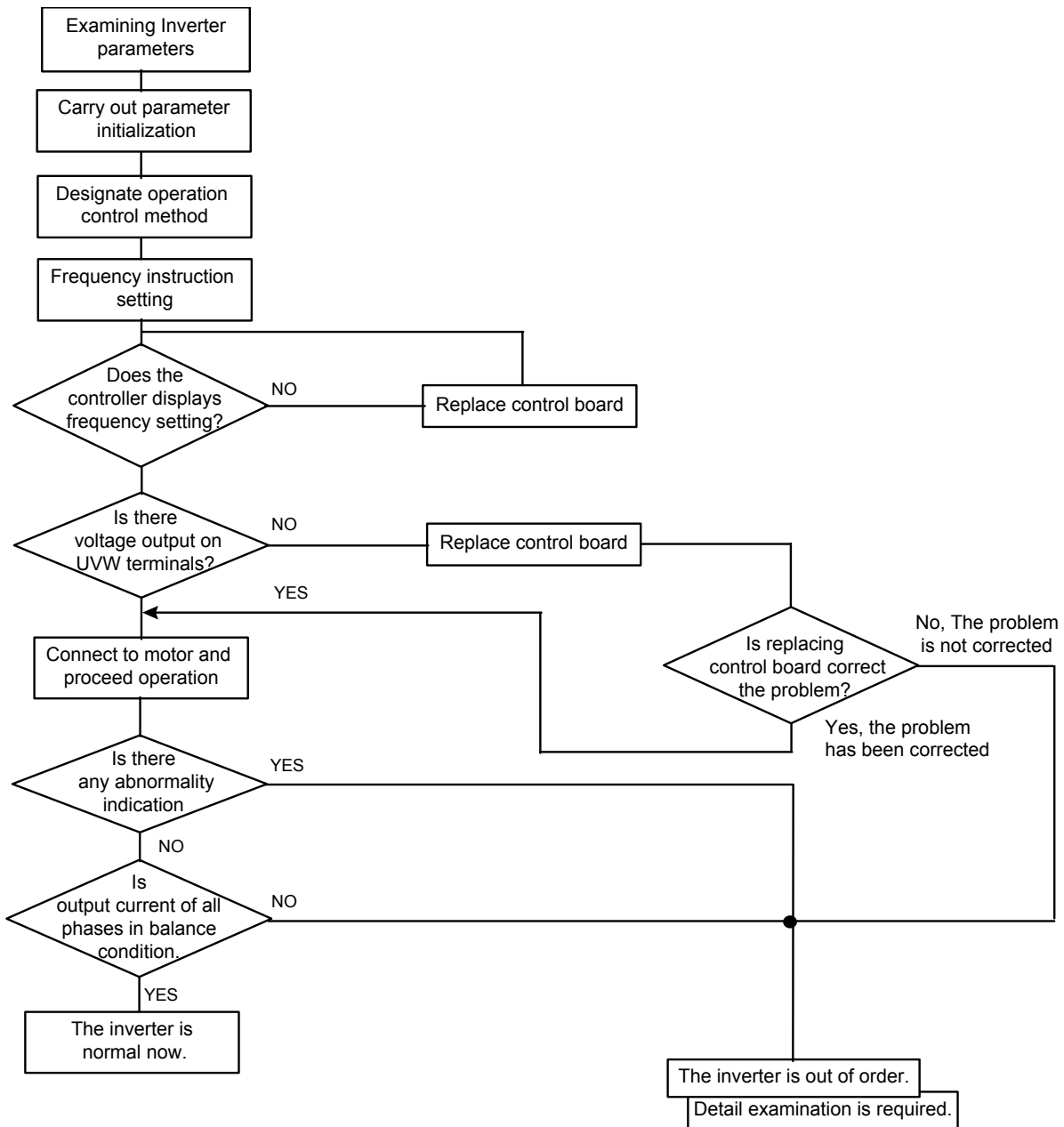

Error handling of malfunction indication of OC.O.L

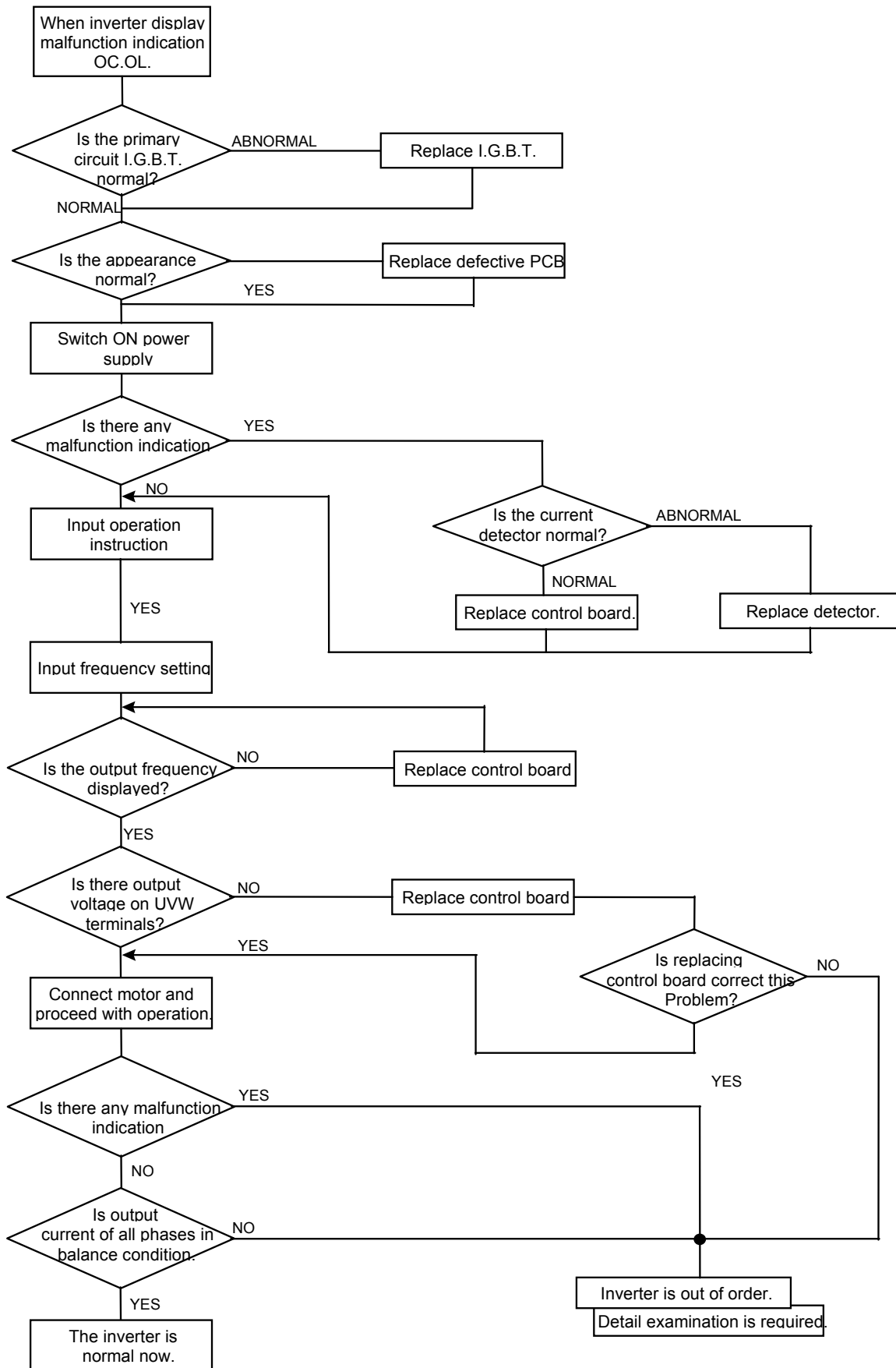

Error handling of malfunction indication of OV.LV

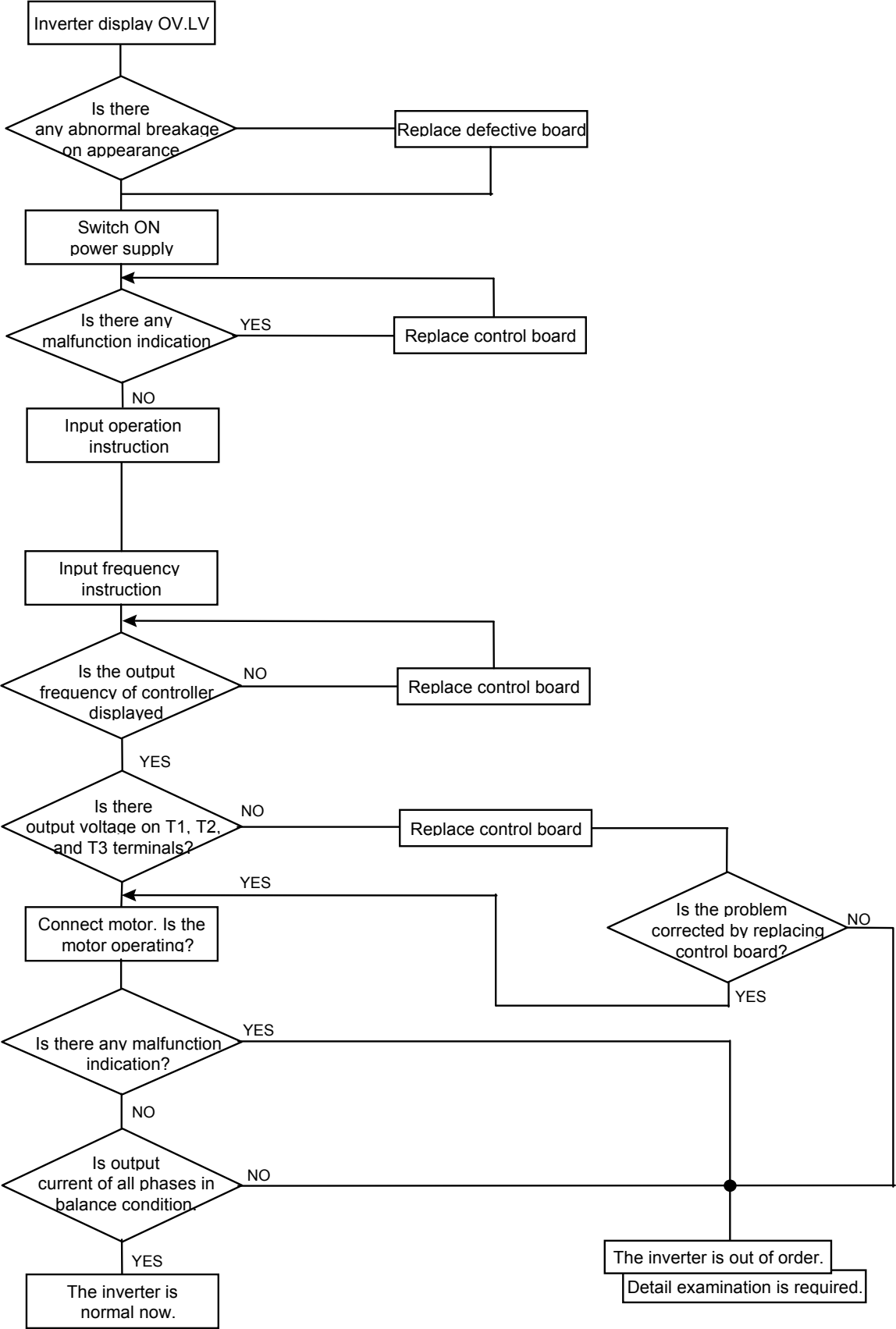

(1). Motor inoperative

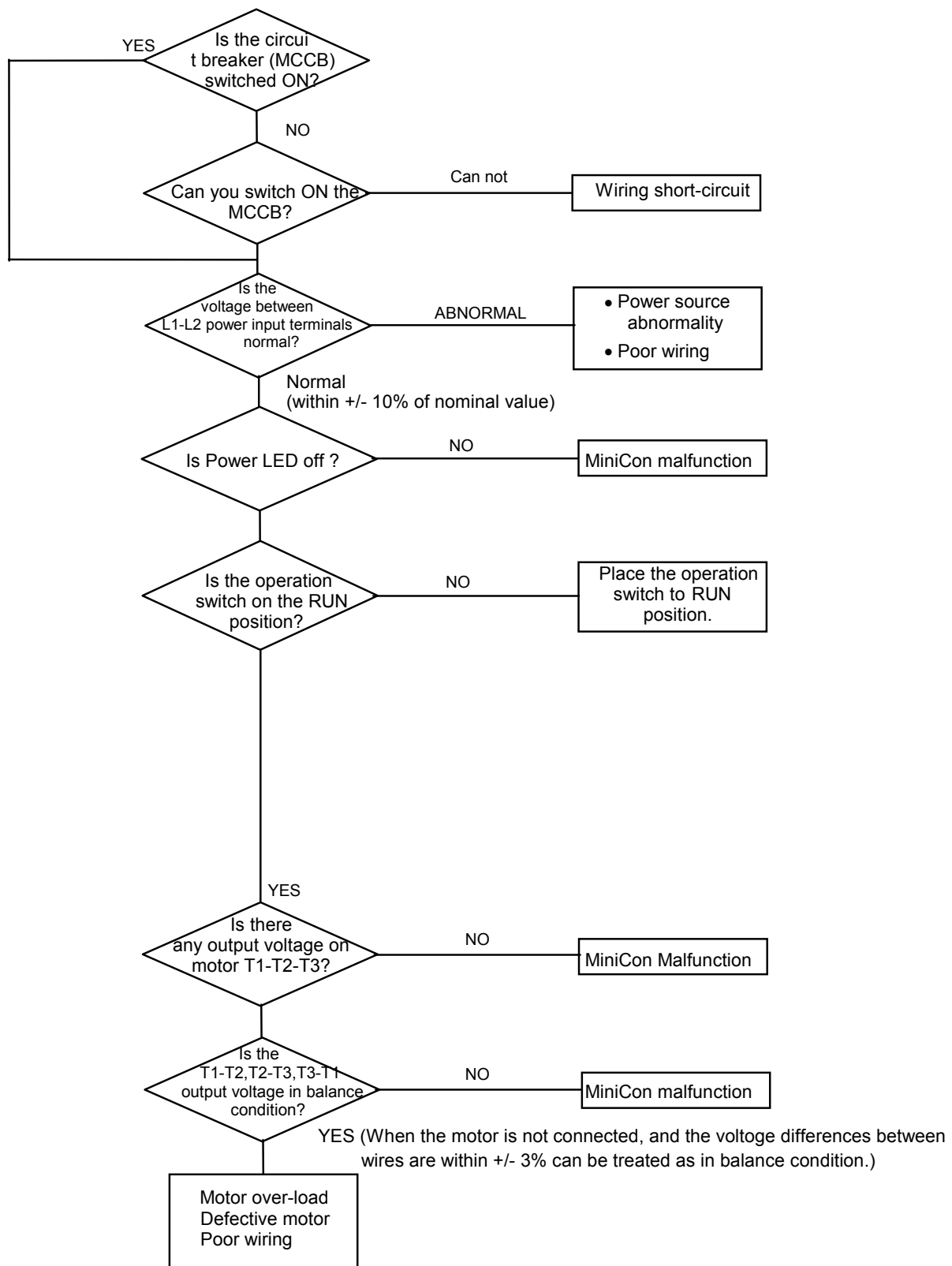

(2). Motor over-heat

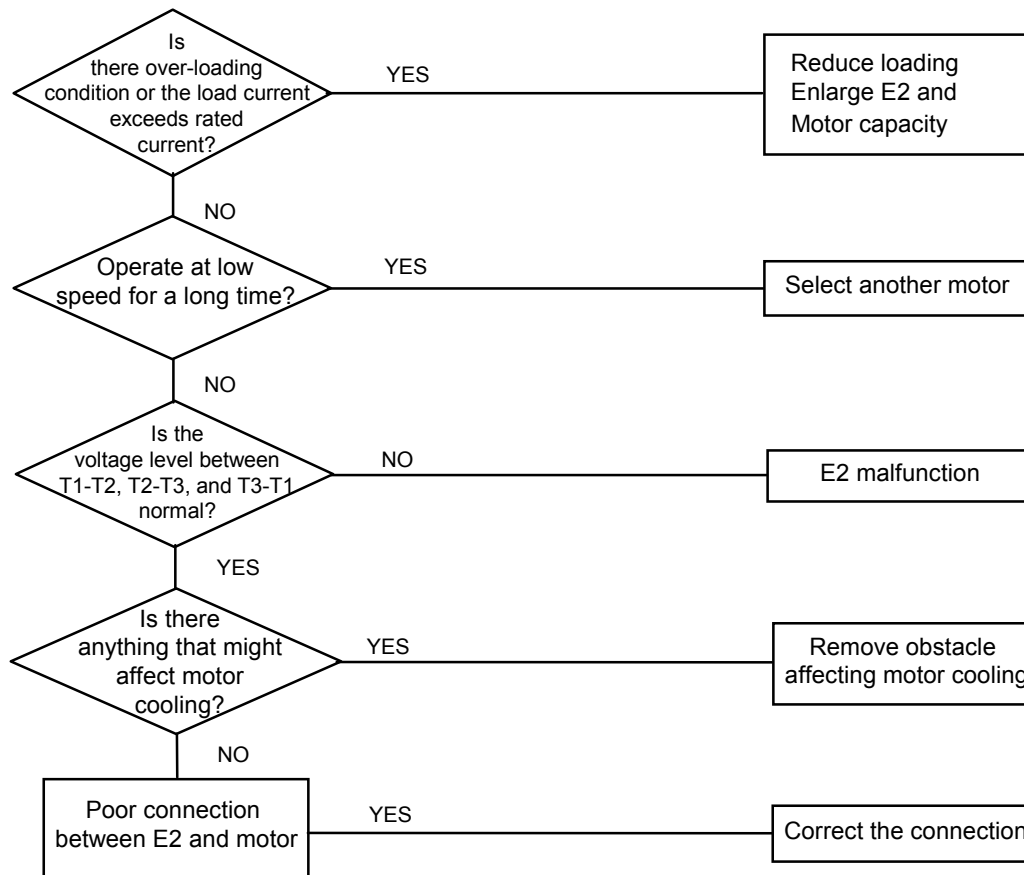

(3). Disturbing motor operation

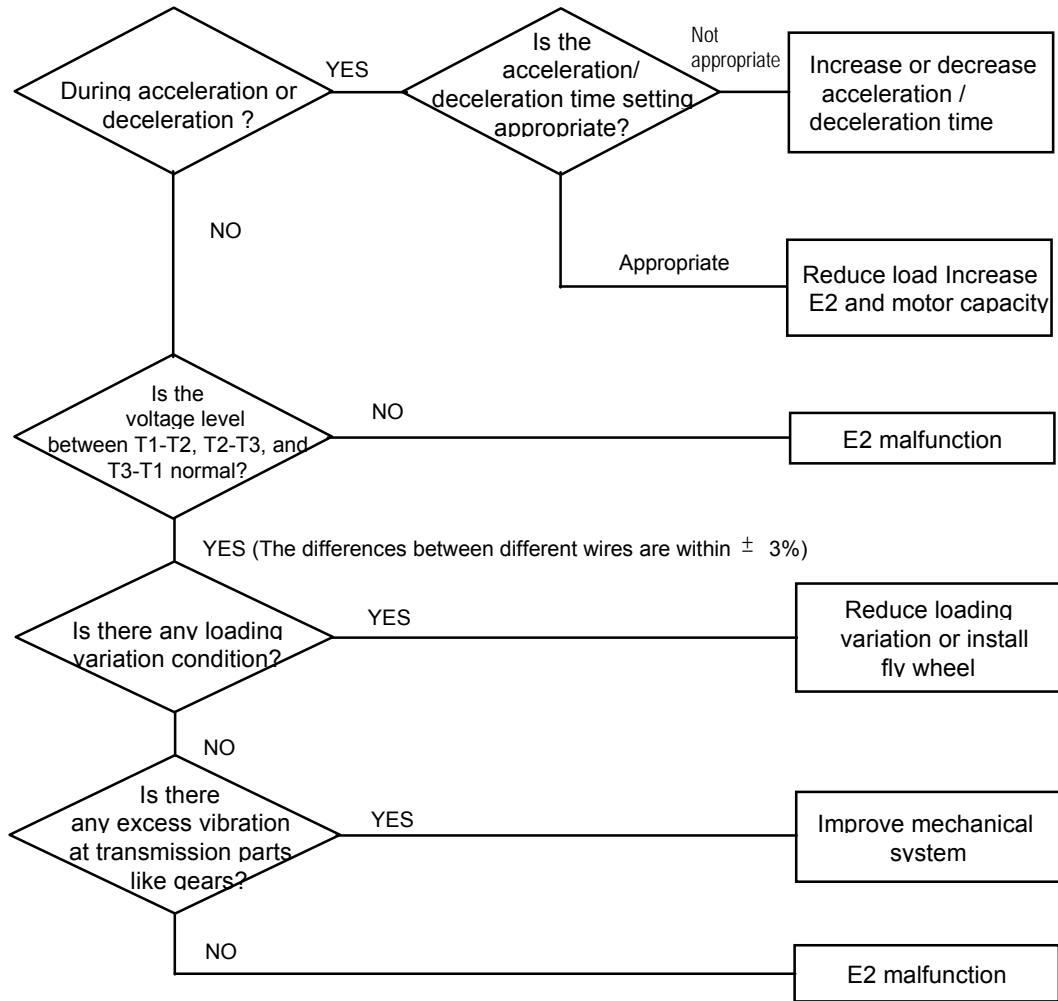

Routine examination and periodical examination

Inverter requires routine and periodical examination and maintenance for a more stable and safer operation. Refer to following table for required examination item for a more stable and safer operation. Carry out examination after the “ Power LED ” indicator goes off for 5 minutes to prevent the maintenance personnel injury caused by the remaining charges in the capacitor of inverter.

Maintenance item	Maintenance description	Examination period		Examination method	Criterion	Countermeasure
		Routine	1 Year			
Installation site environment	Reconfirm environment temperature and humidity	○		Refer to installation instructions and measure with thermometer and hygrometer	Temperature: -10~40 OC Humidity: under 95% without condensing	Improve installation site environment
	Check and remove any flammable material nearby	○		Visual inspection	No foreign object	

Maintenance item	Maintenance description	Examination period		Examination method	Criterion	Countermeasure
		Routine	1 Year			
Inverter Installation and grounding	Is there any abnormal vibration on the installation site?	<input type="radio"/>		Visual and audio inspection	No foreign object	Tighten loose screw
	Is the grounding resistance within acceptable range?		<input type="radio"/>	Measure resistance by multi-meter	200V class under 100 ohm	Improve grounding
Input power source voltage	Is the voltage of the primary circuitry normal?	<input type="radio"/>		Measure voltage by multi-meter	Voltage level conforming specification	Improve input power source
Inverter external terminal mounting screw	Is the tighten parts secured?		<input type="radio"/>	Visual inspection. Use screwdriver to verify screw tightness	No abnormality	Tighten loose screw or return for repair
	Is there any sign of breakage on the terminal panel?		<input type="radio"/>			
	Is there any obvious rusty condition?		<input type="radio"/>			
Internal wiring of inverter	Is it deformed or skewed?		<input type="radio"/>	Visual inspection	No abnormality	Replace or return for repair
	Is the insulation of wire broken?		<input type="radio"/>			
Heat-sink	Is it accumulating dust or dirt?	<input type="radio"/>		Visual inspection	No abnormality	Clean up dust or dirt
PCB	Is it accumulating conductive metal or oil stain?		<input type="radio"/>	Visual inspection	No abnormality	Clean up or replace PCB
	Is there any over-heated or burnt component?		<input type="radio"/>			
Cooling fan	Is there any abnormal vibration or noise?		<input type="radio"/>	Visual and audio inspection	No abnormality	Replace cooling fan
	Is it accumulating dust or dirt?	<input type="radio"/>		Visual inspection		Clean up
Power component	Is it accumulating dust or dirt?		<input type="radio"/>	Visual inspection	No abnormality	Clean up
	Examine resistance between each terminal		<input type="radio"/>	Measure by multi-meter	No short-circuit or open-circuit on the three-phase output	Replace power component or inverter
Capacitor	Is there any sign of strange odor or leakage?	<input type="radio"/>		Visual inspection	No abnormality	Replace capacitor or inverter
	Is there any sign of swelling or bulging?	<input type="radio"/>				

Chapter 4 : Maintenance and Peripherals

Maintenance and Examination

Frequent examination and maintenance is not required for T-VERTER.

To maintain appropriate reliability for a long term of time, please proceed with following periodical examination. Remember to turn off power supply and wait till the Power LED went off before proceed. (Due to the large amount of remaining charges in the internal capacitors.)

- (1) Clean out internal dust and dirt.
- (2) Check out mounting screws on every terminal and parts. Tighten loose screws.
- (3) Dielectric strength test
 - (a) Remove all conducting wires between T-VERTER and outside world. Power must be turned OFF.
 - (b) The dielectric strength test inside T-VERTER should be carried out only for T-VERTER major circuitry. Use DC 500V: high resistance meter. Measured resistance should be higher than 100M ohm.

CAUTION: Do not perform dielectric strength test to the control circuit.

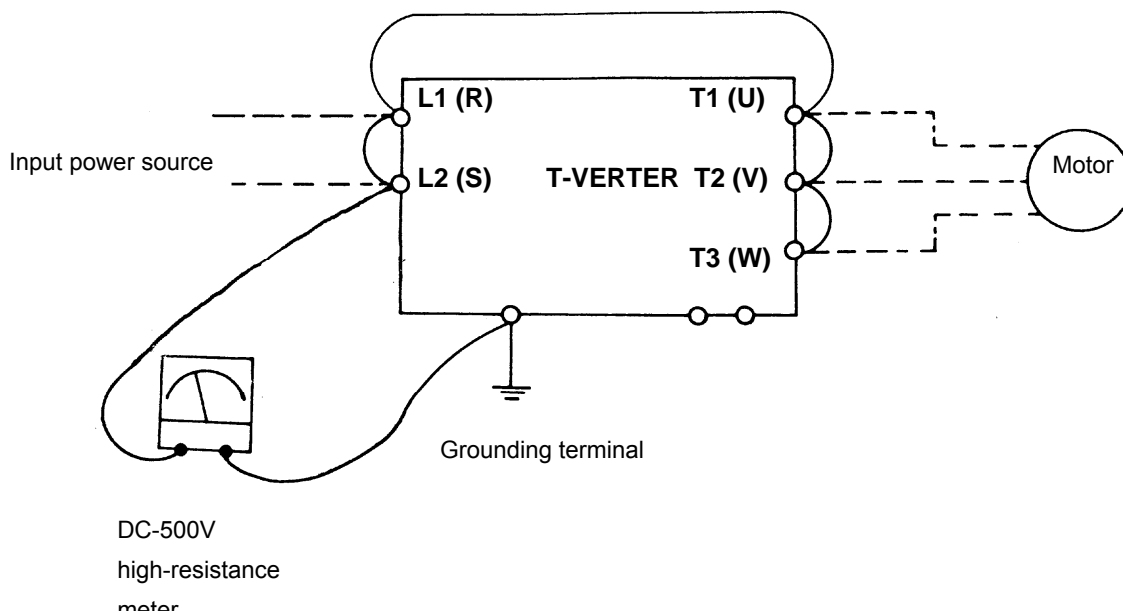

Connection for dielectric strength test

Voltage Current Measurement

The voltage and current measurement on the primary and secondary side may be different for the reason of the instrumentation and the high frequency wave. Refer to following diagram for measurement:

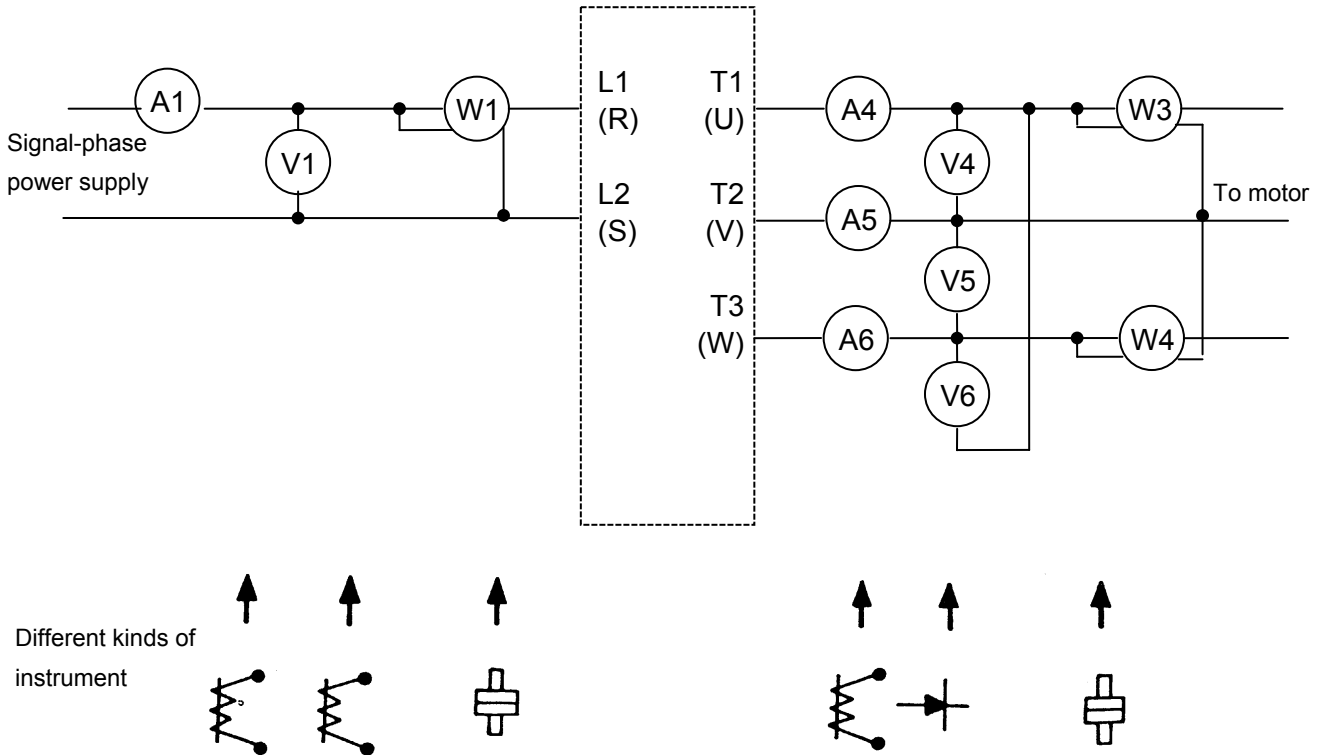

Measurement	Measuring point	Instrument	NOTE (Measurement criterion)
Input voltage V_i	(V1)	Moving-iron	
Input current I_i	(A1)	Moving-iron	
Input power P_i	(W1)	Power-meter	$P=W1$
Input power factor PF_i	Calculate power factor by the input voltage, input current and input power $PF_i = \frac{P_i}{\sqrt{3}V_i \cdot I_i} \times 100\%$		
Output voltage V_o	(V4) (V5) (V6)	Rectifier (Moving-iron not allowed)	Maximum voltage difference between wires under 3%

(A4) (A5)

Output Current I_o	Ⓐ	Moving-iron	Under T-VERTER rated current
Measurement	Measuring point	Instrument	NOTE (Measurement criterion)
Output power P_o	Ⓦ ₃ Ⓦ ₄	Power-meter	$P_o=W_3+W_4$
Output power factor PF_o	$PF_o = \frac{P_o}{\sqrt{3}V_0 \cdot I_o} \times 100\%$		

Input AC Reactor Specification

Model	Input AC Reactor	
	Current value (A)	Inductance (m H)
E2-2P2-M1F	3	7.0
E2-2P5-M1F	5.2	4.2
E2-201-M1F	9.4	2.1
E2-202-M1F		
E2-203-M1F		

EMI Filter (class B) Specification

Model	Dimension(mm)	Current(A)	Inverter model
E2F-2102	156X76X25	10A	E2-2P2-M1F E2-2P5-M1F E2-201-M1F

DIN RAIL Specification

Model	Dimension	Inverter model
DIN E2-201	130x72x7.5	E2-2P2-M1F E2-2P5-M1F E2-201-M1F E2-2P2-M1 E2-2P5-M1 E2-201-M1

PARAMETERS TABLE

CUSTOMER				MODEL			
APPLICATION				TELEPHONE			
ADDRESS							
Fn_##	value	Fn_##	value	Fn_##	value	Fn_##	value
Fn_00		Fn_11		Fn_22		Fn_23	
Fn_01		Fn_12		Fn_24		Fn_25	
Fn_02		Fn_13		Fn_26		Fn_27	
Fn_03		Fn_14		Fn_28		Fn_29	
Fn_04		Fn_15		Fn_30			
Fn_05		Fn_16					
Fn_06		Fn_17					
Fn_07		Fn_18					
Fn_08		Fn_19					
Fn_09		Fn_20					
Fn_10		Fn_21					