

# **FR-A700**

Frequency Inverter

Instruction Manual

# **FR-A740 EC**



**Instruction Manual**  
**Inverter FR-A700 EC**  
**Art. no.: 207935**

<b>Version</b>			<b>Changes / Additions / Corrections</b>	
A	11/2008	pdp-gb	First Edition	
B	11/2009	pdp-gb	General:	Various Corrections
B1	09/2010		Page 3-47:	Thermal Relay Type Name
C	02/2012	pdp-dk	Additions:	<ul style="list-style-type: none"><li>– Description of the serial number (section 1.2)</li><li>– Magnetic flux decay output shutoff function (Pr. 850)</li><li>– Motor temperature detection signal (when using a dedicated vector motor with thermistor and FR-A7AZ)</li><li>– Motor temperature monitor output (when using a dedicated vector motor with thermistor and FR-A7AZ)</li><li>– Additional function for stop-on-contact control (Pr. 270)</li></ul>





---

Thank you for choosing this Mitsubishi inverter.

This instruction manual provides instructions for advanced use of the FR-A700 series inverters. Incorrect handling might cause an unexpected fault. Before using the inverter, always read this instruction manual to use the equipment to its optimum.

## Safety instructions

Do not attempt to install, operate, maintain or inspect the inverter until you have read through this instruction manual carefully and can use the equipment correctly. Do not use the inverter until you have a full knowledge of the equipment, safety information and instructions. In this instruction manual, the safety instruction levels are classified into "WARNING" and "CAUTION".



**WARNING:**

*Assumes that incorrect handling may cause hazardous conditions, resulting in death or severe injury.*



**CAUTION:**

*Assumes that incorrect handling may cause hazardous conditions, resulting in medium or slight injury, or may cause physical damage only.*

Note that even the CAUTION level may lead to a serious consequence according to conditions. Please follow strictly the instructions of both levels because they are important to personnel safety.

---

## Electric Shock Prevention



### WARNING:

- *While power is on or when the inverter is running, do not open the front cover. Otherwise you may get an electric shock.*
- *Do not run the inverter with the front cover removed. Otherwise, you may access the exposed high-voltage terminals or the charging part of the circuitry and get an electric shock.*
- *Even if power is off, do not remove the front cover except for wiring or periodic inspection. You may access the charged inverter circuits and get an electric shock.*
- *Before starting wiring or inspection, check to make sure that the operation panel indicator is off, wait for at least 10 minutes after the power supply has been switched off, and check that there are no residual voltage using a tester or the like. The capacitor is charged with high voltage for some time after power off and it is dangerous.*
- *This inverter must be earthed. Earthing must conform to the requirements of national and local safety regulations and electrical codes. (JIS, NEC section 250, IEC 536 class 1 and other applicable standards)*
- *Any person who is involved in the wiring or inspection of this equipment should be fully competent to do the work.*
- *Always install the inverter before wiring. Otherwise, you may get an electric shock or be injured.*
- *Perform setting dial and key operations with dry hands to prevent an electric shock. Otherwise you may get an electric shock. Perform setting dial and key operations with dry hands to prevent an electric shock. Otherwise you may get an electric shock.*
- *Do not subject the cables to scratches, excessive stress, heavy loads or pinching. Otherwise you may get an electric shock.*
- *Do not replace the cooling fan while power is on. It is dangerous to replace the cooling fan while power is on.*
- *Do not touch the printed circuit board with wet hands. You may get an electric shock.*

## Fire Prevention



### CAUTION:

- *Mount the inverter to non-combustible surface such as metal or concrete. Mounting it to or near combustible material can cause a fire.*
- *If the inverter has become faulty, switch off the inverter power. A continuous flow of large current could cause a fire.*
- *When using a brake resistor, make up a sequence that will turn off power when an alarm signal is output. Otherwise, the brake resistor may excessively overheat due to damage of the brake transistor and such, causing a fire.*
- *Do not connect a resistor directly to the DC terminals P, N. This could cause a fire and destroy the inverter. The surface temperature of braking resistors can far exceed 100°C for brief periods. Make sure that there is adequate protection against accidental contact and a safe distance is maintained to other units and system parts.*

## Injury Prevention



### CAUTION:

- **Apply only the voltage specified in the instruction manual to each terminal. Otherwise, burst, damage, etc. may occur.**
- **Ensure that the cables are connected to the correct terminals. Otherwise, burst, damage, etc. may occur.**
- **Always make sure that polarity is correct to prevent damage, etc. Otherwise, burst, damage, etc. may occur.**
- **While power is on or for some time after power-off, do not touch the inverter as it is hot and you may get burnt.**

## Additional Instructions

Also note the following points to prevent an accidental failure, injury, electric shock, etc.

### Transportation and installation



### CAUTION:

- **When carrying products, use correct lifting gear to prevent injury.**
- **Do not stack the inverter boxes higher than the number recommended.**
- **Ensure that installation position and material can withstand the weight of the inverter. Install according to the information in the instruction manual.**
- **Do not install or operate the inverter if it is damaged or has parts missing. This can result in breakdowns.**
- **When carrying the inverter, do not hold it by the front cover or setting dial; it may fall off or fail.**
- **Do not stand or rest heavy objects on the product.**
- **Check the inverter mounting orientation is correct.**
- **Prevent other conductive bodies such as screws and metal fragments or other flammable substance such as oil from entering the inverter.**
- **As the inverter is a precision instrument, do not drop or subject it to impact.**
- **Use the inverter under the following environmental conditions. Otherwise, the inverter may be damaged**

Operating Condition		FR-A740
Ambient temperature	LD (150%), ND (200%, initial value) and HD (250%)	-10°C to +50°C (non-freezing)
	SLD (120%)	-10°C to +40°C (non-freezing)
Ambient humidity		90% RH or less (non-condensing)
Storage temperature		-20°C to +65°C <sup>①</sup>
Atmosphere		Indoors (free from corrosive gas, flammable gas, oil mist, dust and dirt)
Altitude		Maximum 1000m above sea level for standard operation. After that derate by 3% for every extra 500m up to 2500m (91%)
Vibration		5.9m/s <sup>2</sup> <sup>②</sup> or less (conforming to JIS C 60068-2-6)

<sup>①</sup> Temperature applicable for a short time, e.g. in transit.

<sup>②</sup> 2.9m/s<sup>2</sup> or less for the 04320 or more.

## Wiring



### CAUTION:

- *Do not install assemblies or components (e. g. power factor correction capacitors) on the inverter output side, which are not approved from Mitsubishi.*
- *The direction of rotation of the motor corresponds to the direction of rotation commands (STF/STR) only if the phase sequence (U, V, W) is maintained.*

## Operation



### WARNING:

- *When you have chosen the retry function, stay away from the equipment as it will restart suddenly after an alarm stop.*
- *The STOP/RESET key is valid only when the appropriate function setting has been made. Prepare an emergency stop switch separately.*
- *Make sure that the start signal is off before resetting the inverter alarm. A failure to do so may restart the motor suddenly.*
- *The inverter can be started and stopped via the serial port communications link or the field bus. However, please note that depending on the settings of the communications parameters it may not be possible to stop the system via these connections if there is an error in the communications system or the data line. In configurations like this it is thus essential to install additional safety hardware that makes it possible to stop the system in an emergency (e.g. controller inhibit via control signal, external motor contactor etc). Clear and unambiguous warnings about this must be posted on site for the operating and service staff.*
- *The load used should be a three-phase induction motor only. Connection of anyother electrical equipment to the inverter output may damage the inverter as well as equipment.*
- *Performing pre-excitation (LX signal and X13 signal) under torque control (real sensorless vector control) may start the motor running at a low speed even when the start command (STF or STR) is not input. The motor may run also at a low speed when the speed limit value = 0 with a start command input. Perform pre-excitation after making sure that there will be no problem in safety if the motor runs.*
- *Do not modify the equipment.*
- *Do not perform parts removal which is not instructed in this manual. Doing so may lead to fault or damage of the inverter.*

**CAUTION:**

- *The electronic thermal relay function does not guarantee protection of the motor from overheating.*
- *Do not use a magnetic contactor on the inverter input for frequent starting/stopping of the inverter.*
- *Use a noise filter to reduce the effect of electromagnetic interference and follow the accepted EMC procedures for proper installation of frequency inverters. Otherwise nearby electronic equipment may be affected.*
- *Take appropriate measures regarding harmonics. Otherwise this can endanger compensation systems or overload generators.*
- *Use a motor designed for inverter operation. (The stress for motor windings is bigger than in line power supply).*
- *When parameter clear or all clear is performed, set again the required parameters before starting operations. Each parameter returns to the initial value.*
- *The inverter can be easily set for high-speed operation. Before changing its setting, fully examine the performances of the motor and machine.*
- *The DC braking function of the frequency inverter is not designed to continuously hold a load. Use an electro-mechanical holding brake on the motor for this purpose.*
- *Before running an inverter which had been stored for a long period, always perform inspection and test operation.*
- *For prevention of damage due to static electricity, touch nearby metal before touching this product to eliminate static electricity from your body.*

**Diagnosis and Settings****CAUTION:**

- *Before starting operation, confirm and adjust the parameters. A failure to do so may cause some machines to make unexpected motions.*

**Emergency stop****CAUTION:**

- *Provide a safety backup such as an emergency brake which will prevent the machine and equipment from hazardous conditions if the inverter fails.*
- *When the breaker on the inverter primary side trips, check for the wiring fault (short circuit), damage to internal parts of the inverter, etc. Identify the cause of the trip, then remove the cause and power on the breaker.*
- *When the protective function is activated (i. e. the frequency inverter switches off with an error message), take the corresponding corrective action as described in the inverter manual, then reset the inverter, and resume operation.*

---

## Maintenance, inspection and parts replacement



### CAUTION:

- *Do not carry out a megger (insulation resistance) test on the control circuit of the inverter.*

## Disposing the inverter



### CAUTION:

- *Treat as industrial waste.*

## General instructions

Many of the diagrams and drawings in instruction manuals show the inverter without a cover, or partially open. Never run the inverter in this status. Always replace the cover and follow this instruction manual when operating the inverter.

---

# Contents

<b>1</b>	<b>Product Checking and Part Identification</b>	
1.1	Inverter Type .....	1-1
1.2	Description of the Case .....	1-2
1.2.1	Accessory .....	1-3
<b>2</b>	<b>Installation</b>	
2.1	Removal and reinstallation of the operation panel .....	2-1
2.2	Removal and reinstallation of the front cover .....	2-2
2.2.1	FR-A740-00023 to 00620-EC .....	2-2
2.2.2	FR-A740-00770 to 12120-EC .....	2-3
2.3	Mounting .....	2-5
2.4	Enclosure design .....	2-6
2.4.1	Inverter installation environment .....	2-6
2.4.2	Inverter placement .....	2-10
2.4.3	Heatsink protrusion attachment (FR-A7CN) .....	2-12
<b>3</b>	<b>Wiring</b>	
3.1	Inverter and peripheral devices .....	3-1
3.1.1	Peripheral devices .....	3-3
3.2	Terminal connection diagram .....	3-5
3.3	Main circuit connection .....	3-7
3.3.1	Specification of main circuit terminal .....	3-7
3.3.2	Terminal layout and wiring .....	3-8
3.3.3	Separate power supply for the control circuit .....	3-16
3.4	Control circuit specifications .....	3-19
3.4.1	Changing the control logic .....	3-24
3.4.2	Control circuit terminals .....	3-27
3.4.3	Wiring method .....	3-27
3.4.4	Wiring instructions .....	3-29
3.5	Connecting the operation panel using a connection cable .....	3-30

3.6	RS-485 terminal block . . . . .	3-31
3.6.1	Communication operation . . . . .	3-32
3.6.2	USB communication specification . . . . .	3-33
3.7	Connection of motor with encoder (vector control) . . . . .	3-34
3.8	Connection of stand-alone option units . . . . .	3-43
3.8.1	Magnetic contactors (MC) . . . . .	3-43
3.8.2	Connection of the dedicated external brake resistor (FR-ABR) . . . . .	3-45
3.8.3	Connection of a brake unit . . . . .	3-48
3.8.4	Connection of the high power factor converter (FR-HC, MT-HC) . . . . .	3-51
3.8.5	Connection of the power regeneration common converter FR-CV (01800 or less) . . . . .	3-53
3.8.6	Connection of power regeneration converter (MT-RC) (02160 or more) . . . . .	3-54
3.8.7	Connection of the power improving DC reactor FR-HEL . . . . .	3-55
3.8.8	Installation of a reactor . . . . .	3-55
3.9	Electromagnetic compatibility (EMC) . . . . .	3-56
3.9.1	Leakage currents and countermeasures . . . . .	3-56
3.9.2	Inverter-generated noises and their reduction techniques . . . . .	3-61
3.9.3	EMC filter . . . . .	3-64
3.9.4	Power supply harmonics . . . . .	3-65
3.9.5	Inverter-driven 400V class motor . . . . .	3-66
<b>4</b>	<b>Operation</b>	
4.1	Precautions for use of the inverter . . . . .	4-1
4.2	Drive the motor . . . . .	4-3
4.3	Operation panel FR-DU07 . . . . .	4-4
4.3.1	Parts of the operation panel . . . . .	4-4
4.3.2	Basic operation (factory setting) . . . . .	4-6
4.3.3	Operation lock . . . . .	4-7
4.3.4	Monitoring of output current and output voltage . . . . .	4-9
4.3.5	First priority monitor . . . . .	4-9
4.3.6	Digital dial push . . . . .	4-9
4.3.7	Change the parameter setting value . . . . .	4-10
4.3.8	Parameter clear . . . . .	4-11
4.3.9	All parameter clear . . . . .	4-12
4.3.10	Parameter copy an parameter verification . . . . .	4-13
4.3.11	Parameter copy . . . . .	4-14
4.3.12	Parameter verification . . . . .	4-16



<b>5</b>	<b>Basic settings</b>	
5.1	Simple mode parameter list . . . . .	5-1
5.1.1	Overheat protection of the motor by the inverter. . . . .	5-3
5.1.2	When the rated motor frequency is 60Hz (Pr. 3). . . . .	5-5
5.1.3	Increase the starting torque (Pr. 0) . . . . .	5-6
5.1.4	Limit the maximum and minimum output frequency (Pr. 1, Pr. 2) . . . . .	5-8
5.1.5	Change the acceleration/deceleration time (Pr. 7, Pr. 8) . . . . .	5-10
5.1.6	Operation mode (Pr. 79) . . . . .	5-12
5.1.7	Large starting torque and low speed torque are necessary (advanced magnetic flux vector control, real sensorless vector control) (Pr. 9, Pr. 71, Pr. 80, Pr. 81, Pr. 800) . . . . .	5-13
5.1.8	Higher accuracy operation using a motor with encoder (Vector control) (Pr. 9, Pr. 71, Pr. 80, Pr. 81, Pr. 359, Pr. 369, Pr. 800). . . . .	5-18
5.1.9	To exhibit the best performance of the motor performance (offline auto tuning) (Pr. 9, Pr. 71, Pr. 83, Pr. 84, Pr. 96) . . . . .	5-24
5.1.10	High accuracy operation unaffected by the motor temperature (online auto tuning) . . . . .	5-30
5.1.11	To perform high accuracy / fast response operation (gain adjustment of real sensorless vector control) (Pr. 818 to Pr. 821, Pr. 880) . . . . .	5-32
5.2	PU operation mode. . . . .	5-40
5.2.1	Set the set frequency to operate. . . . .	5-41
5.2.2	Use the digital dial like a potentiometer to perform operation . . . . .	5-42
5.2.3	Use switches to give the frequency command (multi-speed setting) . . . . .	5-43
5.2.4	Perform frequency setting by analog voltage input. . . . .	5-45
5.2.5	Perform frequency setting by analog current input . . . . .	5-47
5.3	External operation . . . . .	5-49
5.3.1	Use the set frequency set by the operation panel (Pr. 79 = 3) . . . . .	5-49
5.3.2	Use switches to give a start command and a frequency command (multi-speed setting) (Pr. 4 to Pr. 6) . . . . .	5-51
5.3.3	Perform frequency setting by analog voltage input. . . . .	5-54
5.3.4	Change the frequency (50Hz) of the maximum value of potentiometer (at 5V) . . . . .	5-57
5.3.5	Perform frequency setting by analog current input . . . . .	5-58
5.3.6	Change the frequency (50Hz) of the maximum value of potentiometer (at 20mA) . . . . .	5-60

<b>6</b>	<b>Parameter</b>	
6.1	Parameter overview	6-1
6.2	Control mode	6-65
6.2.1	What is vector control?	6-66
6.2.2	Change the control method (Pr. 80, Pr. 81, Pr. 451, Pr. 800)	6-70
6.3	Speed control by real sensorless vector control, vector control	6-76
6.3.1	Selection method of real sensorless vector control (speed control)	6-77
6.3.2	Torque limit level setting for speed control (Pr. 22, Pr. 803, Pr. 810 to Pr. 817, Pr. 858, Pr. 868, Pr. 874)	6-80
6.3.3	To perform high accuracy/fast response operation (gain adjustment of real sensorless vector control and vector control) (Pr. 818 to Pr. 821, Pr. 830, Pr. 831, Pr. 880)	6-88
6.3.4	Speed feed forward control, model adaptive speed control (Pr. 828, Pr. 877 to Pr. 881)	6-99
6.3.5	Torque biases (Pr. 840 to Pr. 848)	6-102
6.3.6	Prevent the motor from overrunning (Pr. 285, Pr. 853, Pr. 873)	6-107
6.3.7	Notch filter (Pr. 862, Pr. 863)	6-109
6.4	Torque control by real sensorless vector control, vector control	6-110
6.4.1	Setting procedure of real sensorless vector control (torque control)	6-110
6.4.2	Setting procedure of vector control (torque control)	6-112
6.4.3	Torque control	6-113
6.4.4	Torque command (Pr. 803 to Pr. 806)	6-113
6.4.5	Speed limit (Pr. 807 to Pr. 809)	6-117
6.4.6	Activation of torque control during start and stop processes	6-121
6.4.7	Gain adjustment of torque control (Pr. 824, Pr. 825, Pr. 834, Pr. 835)	6-124
6.5	Position control by vector control	6-127
6.5.1	Position control	6-127
6.5.2	Conditional position feed function by contact input (Pr. 419, Pr. 464 to Pr. 494)	6-131
6.5.3	Position control (Pr. 419, Pr. 428 to Pr. 430) by inverter pulse train input	6-134
6.5.4	Setting of the electronic gear (Pr. 420, Pr. 421, Pr. 424)	6-137
6.5.5	Setting of positioning adjustment parameter (Pr. 426, Pr. 427)	6-140
6.5.6	Gain adjustment of position control (Pr. 422, Pr. 423, Pr. 425)	6-141
6.5.7	Trouble shooting for when position control is not exercised normally	6-143
6.6	Adjustment of real sensorless vector control, vector control	6-144
6.6.1	Speed detection filter and torque detection filter (Pr. 823, Pr. 827, Pr. 833, Pr. 837)	6-144
6.6.2	Excitation ratio	6-146

---

6.7	Adjust the output torque of the motor (current) . . . . .	6-147
6.7.1	Manual torque boost (Pr. 0, Pr. 46, Pr. 112) . . . . .	6-147
6.7.2	Advanced magnetic flux vector control (Pr. 71, Pr. 80, Pr. 81, Pr. 89, Pr. 450, Pr. 451, Pr. 453, Pr. 454, Pr. 569, Pr. 800) . . . . .	6-150
6.7.3	Slip compensation (Pr. 245 to Pr. 247) . . . . .	6-154
6.7.4	Stall prevention operation (Pr. 22, Pr. 23, Pr. 48, Pr. 49, Pr. 66, Pr. 114, Pr. 115, Pr. 148, Pr. 149, Pr. 154, Pr. 156, Pr. 157, Pr. 858, Pr. 868) . . . . .	6-155
6.7.5	Multiple rating (SLD = Super Light Duty, LD = Light Duty, ND = Normal Duty, HD = Heavy Duty) (Pr. 570) . . . . .	6-166
6.8	Limit the output frequency . . . . .	6-168
6.8.1	Maximum and minimum frequency (Pr. 1, Pr. 2, Pr. 18) . . . . .	6-168
6.8.2	Avoid mechanical resonance points (Frequency jump) (Pr. 31 to Pr. 36) . . . . .	6-170
6.9	Set V/f pattern. . . . .	6-172
6.9.1	Base frequency, voltage (Pr. 3, Pr. 19, Pr. 47) . . . . .	6-172
6.9.2	Load pattern selection (Pr. 14) . . . . .	6-175
6.9.3	Elevator mode (automatic acceleration/deceleration) (Pr. 61, Pr. 64, Pr. 292) . . . . .	6-178
6.9.4	Adjustable 5 points V/f (Pr. 71, Pr. 100 bis Pr. 109) . . . . .	6-181
6.10	Frequency setting by external terminals. . . . .	6-183
6.10.1	Multi-speed setting operation . . . . .	6-183
6.10.2	Jog operation (Pr. 15, Pr. 16) . . . . .	6-186
6.10.3	Input compensation of multi-speed and remote setting (Pr. 28) . . . . .	6-190
6.10.4	Remote setting function (Pr. 59) . . . . .	6-191
6.11	Acceleration and deceleration . . . . .	6-195
6.11.1	Acceleration and deceleration time . . . . .	6-195
6.11.2	Starting frequency and start-time hold function. . . . .	6-199
6.11.3	Acceleration and deceleration pattern (Pr. 29, Pr. 140 to Pr. 143, Pr. 380 to Pr. 383, Pr. 516 to Pr. 519) . . . . .	6-201
6.11.4	Shortest acceleration/deceleration (automatic acceleration/deceleration) (Pr. 61 to Pr. 63, Pr. 292, Pr. 293) . . . . .	6-208
6.12	Selection and protection of a motor . . . . .	6-212
6.12.1	Motor protection from overheat (Electronic thermal relay function) (Pr. 9) . . . . .	6-212
6.12.2	Applied motor (Pr. 71, Pr. 450) . . . . .	6-218
6.12.3	Offline auto tuning (Pr. 71, Pr. 80 to Pr. 84, Pr. 90 to Pr. 94, Pr. 96, Pr. 450, Pr. 453 to Pr. 463, Pr. 684, Pr. 859, Pr. 860) . . . . .	6-222
6.12.4	Online auto tuning (Pr. 95, Pr. 574) . . . . .	6-236

---

6.13	Motor brake and stop operation . . . . .	6-241
6.13.1	DC injection brake and zero speed control, servo lock (LX signal, X13 signal, Pr. 10 to Pr. 12, Pr. 802, Pr. 850) . . . . .	6-241
6.13.2	Selection of a regenerative brake (Pr. 30, Pr. 70) . . . . .	6-249
6.13.3	Stop selection (Pr. 250) . . . . .	6-257
6.13.4	Stop-on contact control function (Pr. 6, Pr. 48, Pr. 270, Pr. 275, Pr. 276) . . . . .	6-259
6.13.5	Brake sequence function (Pr. 278 to Pr. 285, Pr. 292) . . . . .	6-264
6.13.6	Orientation control (Pr. 350 bis Pr. 366, Pr. 369, Pr. 393, Pr. 396 to Pr. 399) . . . . .	6-269
6.14	Function assignment of external terminals . . . . .	6-289
6.14.1	Input terminal function selection (Pr. 178 to Pr. 189) . . . . .	6-289
6.14.2	Inverter output shutoff signal (MRS signal, Pr. 17) . . . . .	6-293
6.14.3	Condition selection of function validity by the second function selection signal (RT) and third function selection signal (X9) (RT signal, X9 signal, Pr. 155) . . . . .	6-295
6.14.4	Start signal selection (Terminal STF, STR, STOP, Pr. 250) . . . . .	6-297
6.14.5	Output terminal function selection (Pr. 190 to Pr. 196) . . . . .	6-301
6.14.6	Detection of output frequency (SU, FU, FU2, FU3, FB, FB2, FB3, LS, Pr. 41 to Pr. 43, Pr. 50, Pr. 116, Pr. 865) . . . . .	6-312
6.14.7	Output current detection function (Y12, Y13, Pr. 150 to Pr. 153, Pr. 166, Pr. 167) . . . . .	6-315
6.14.8	Detection of output torque (TU signal, Pr. 864) . . . . .	6-317
6.14.9	Remote output function (REM, Pr. 495 to Pr. 497) . . . . .	6-318
6.15	Monitor display and monitor output signals . . . . .	6-321
6.15.1	Speed display and speed setting (Pr. 37, Pr. 144) . . . . .	6-321
6.15.2	DU/PU monitor display selection (Pr. 52, Pr. 54, Pr. 158, Pr. 170, Pr. 171, Pr. 268, Pr. 563, Pr. 564, Pr. 891) . . . . .	6-324
6.15.3	CA, AM terminal function selection (Pr. 55, Pr. 56, Pr. 867, Pr. 869) . . . . .	6-333
6.15.4	Terminal CA, AM calibration [C0 (Pr. 900), C1 (Pr. 901), C8 (Pr. 930) to C11 (Pr. 931)] . . . . .	6-336
6.16	Operation selection at power failure . . . . .	6-340
6.16.1	Automatic restart (Pr. 57, Pr. 58, Pr. 162 to Pr. 165, Pr. 299, Pr. 611) . . . . .	6-340
6.16.2	Power failure-time deceleration-to-stop function (Pr. 261 to Pr. 266, Pr. 294) . . . . .	6-349

---

6.17	Operation setting at alarm occurrence . . . . .	6-354
6.17.1	Retry function . . . . .	6-354
6.17.2	Alarm code output selection . . . . .	6-358
6.17.3	Input/output phase failure protection selection (Pr. 251, Pr. 872) . . . . .	6-359
6.17.4	Overspeed detection (Pr. 374) . . . . .	6-360
6.17.5	Encoder signal loss detection (Pr. 376) . . . . .	6-360
6.17.6	Fault definition (Pr. 875) . . . . .	6-361
6.18	Energy saving operation and energy saving monitor . . . . .	6-362
6.18.1	Energy saving control and optimum excitation control (Pr. 60) . . . . .	6-362
6.18.2	Energy saving monitor (Pr. 891 to Pr. 899) . . . . .	6-363
6.19	Motor noise, noise reduction . . . . .	6-370
6.19.1	PWM carrier frequency and Soft-PWM control (Pr. 72, Pr. 240, Pr. 260) . . . . .	6-370
6.20	Frequency/torque setting by analog input (terminals 1, 2 and 4) . . . . .	6-372
6.20.1	Function assignment of analog input terminal (Pr. 858, Pr. 868) . . . . .	6-372
6.20.2	Analog input selection (Pr. 73, Pr. 267) . . . . .	6-374
6.20.3	Analog input compensation (Pr. 73, Pr. 242, Pr. 243, Pr. 252, Pr. 253) . . . . .	6-380
6.20.4	Response level of analog input and noise elimination (Pr. 74, Pr. 822, Pr. 826, Pr. 832, Pr. 836, Pr. 849) . . . . .	6-383
6.20.5	Bias and gain of frequency setting voltage (current) [Pr. 125, Pr. 126, Pr. 241, C2 (Pr. 902) to C7 (Pr. 905), C12 (Pr. 917) bis C15 (Pr. 918)] . . . . .	6-385
6.20.6	Bias and gain of torque (magnetic flux) setting voltage (current) [Pr. 241, C16 (Pr. 919) to C19 (Pr. 920), C38 (Pr. 932) to C41 (Pr. 933)] . . . . .	6-394
6.20.7	4mA input check of current input (Pr. 573) . . . . .	6-403
6.21	Misoperation prevention and parameter setting restriction. . . . .	6-406
6.21.1	Reset selection/disconnected PU detection/ PU stop selection (Pr. 75) . . . . .	6-406
6.21.2	Parameter write selection (Pr. 77) . . . . .	6-411
6.21.3	Reverse rotation prevention selection (Pr. 78) . . . . .	6-414
6.21.4	User groups (Pr. 160, Pr. 172 to Pr. 174) . . . . .	6-415
6.22	Selection of operation mode and operation location . . . . .	6-418
6.22.1	Operation mode selection (Pr. 79) . . . . .	6-418
6.22.2	Operation mode at power on (Pr. 79, Pr. 340) . . . . .	6-430
6.22.3	Operation command source and speed command source during communication operation (Pr. 338, Pr. 339, Pr. 550, Pr. 551) . . . . .	6-432

6.23	Communication operation and setting	6-440
6.23.1	PU connector	6-440
6.23.2	RS-485 terminals	6-443
6.23.3	Initial settings and specifications of RS-485 communication (Pr. 117 to Pr. 124, Pr. 331 to Pr. 337, Pr. 341, Pr. 549)	6-448
6.23.4	Communication EEPROM write selection (Pr. 342)	6-450
6.23.5	Mitsubishi inverter protocol (computer link communication)	6-451
6.23.6	Modbus-RTU communication (Pr. 331, Pr. 332, Pr. 334, Pr. 343, Pr. 539, Pr. 549)	6-470
6.23.7	Operation by PLC function (Pr. 414 to Pr. 417, Pr. 498, Pr. 506 to 515)	6-489
6.23.8	USB communication (Pr. 547, Pr. 548)	6-490
6.24	Special operation	6-491
6.24.1	PID control (Pr. 127 to Pr. 134, Pr. 575 to Pr. 577)	6-491
6.24.2	Commercial power supply-inverter switchover function (Pr. 57, Pr. 58, Pr. 135 to Pr. 139, Pr. 159)	6-505
6.24.3	Load torque high speed frequency control (Pr. 4, Pr. 5, Pr. 270 to Pr. 274)	6-512
6.24.4	Droop control (Pr. 286 to Pr. 288)	6-516
6.24.5	Frequency setting by pulse train input (Pr. 291, Pr. 384 to Pr. 386)	6-518
6.24.6	Encoder feedback control (Pr. 144, Pr. 285, Pr. 359, Pr. 367 to Pr. 369)	6-521
6.24.7	Traverse function (Pr. 592 to Pr. 597)	6-524
6.24.8	Regeneration avoidance function (Pr. 882 to Pr. 886)	6-527
6.25	Useful functions	6-530
6.25.1	Cooling fan operation selection (Pr. 244)	6-530
6.25.2	Display of the life of the inverter parts (Pr. 255 to Pr. 259)	6-531
6.25.3	Maintenance timer alarm (Pr. 503, Pr. 504)	6-535
6.25.4	Current average value monitor signal (Pr. 555 to Pr. 557)	6-536
6.25.5	Free parameters (Pr. 888, Pr. 889)	6-540
6.26	Setting for the parameter unit, operation panel	6-541
6.26.1	PU display language selection (Pr. 145)	6-541
6.26.2	Operation panel frequency setting/key lock operation selection (Pr. 161)	6-542
6.26.3	Buzzer control (Pr. 990)	6-542
6.26.4	PU contrast adjustment (Pr. 991)	6-542

---

<b>7</b>	<b>Troubleshooting</b>	
7.1	List of alarm display . . . . .	7-2
7.2	Causes and corrective actions . . . . .	7-5
7.3	Reset method of protective function . . . . .	7-23
7.4	LED display . . . . .	7-24
7.5	Check and clear of the alarm history . . . . .	7-25
7.6	Check first when you have troubles . . . . .	7-27
7.6.1	Motor does not rotate as commanded . . . . .	7-27
7.6.2	Motor generates abnormal noise . . . . .	7-28
7.6.3	Motor generates heat abnormally . . . . .	7-28
7.6.4	Motor rotates in opposite direction . . . . .	7-28
7.6.5	Speed greatly differs from the setting . . . . .	7-28
7.6.6	Acceleration/deceleration is not smooth . . . . .	7-29
7.6.7	Motor current is large . . . . .	7-29
7.6.8	Speed does not increase . . . . .	7-29
7.6.9	Speed varies during operation . . . . .	7-29
7.6.10	Operation mode is not changed properly . . . . .	7-30
7.6.11	Operation panel (FR-DU07) display is not operating . . . . .	7-30
7.6.12	POWER lamp is not lit. . . . .	7-30
7.6.13	Parameter write cannot be performed. . . . .	7-30
7.7	Meters and measuring methods . . . . .	7-31
7.7.1	Measurement of powers . . . . .	7-32
7.7.2	Measurement of voltages and use of PT . . . . .	7-33
7.7.3	Measurement of currents . . . . .	7-33
7.7.4	Use of CT and transducer . . . . .	7-34
7.7.5	Measurement of inverter input power factor . . . . .	7-34
7.7.6	Measurement of converter output voltage (across terminals P/+ and N/-) . . . . .	7-34

<b>8</b>		<b>Maintenance and inspection</b>	
8.1	Inspection . . . . .		8-1
	8.1.1 Daily inspection . . . . .		8-1
	8.1.2 Periodic inspection . . . . .		8-1
	8.1.3 Daily and periodic inspection . . . . .		8-2
	8.1.4 Display of the life of the inverter parts . . . . .		8-4
	8.1.5 Checking the inverter and converter modules . . . . .		8-7
	8.1.6 Cleaning . . . . .		8-8
	8.1.7 Replacement of parts . . . . .		8-8
	8.1.8 Inverter replacement . . . . .		8-14
8.2	Measurements on the main circuit . . . . .		8-15
	8.2.1 Insulation resistance test using megger . . . . .		8-15
	8.2.2 Pressure test . . . . .		8-15
	8.2.3 Measurement of voltages and currents . . . . .		8-16
<b>A</b>		<b>Appendix</b>	
A.1	Specifications FR-A740-00023 to -01160 . . . . .		A-1
A.2	Specifications FR-A740-01800 to -12120 . . . . .		A-3
A.3	Common specifications . . . . .		A-5
A.4	Outline dimension drawings . . . . .		A-7
	A.4.1 FR-A740-00023 to -00126 . . . . .		A-7
	A.4.2 FR-A740-00170 to -00380 . . . . .		A-8
	A.4.3 FR-A740-00470 and -00620 . . . . .		A-9
	A.4.4 FR-A740-00770 to -01160 . . . . .		A-10
	A.4.5 FR-A740-01800 . . . . .		A-11
	A.4.6 FR-A740-02160 and -02600 . . . . .		A-12
	A.4.7 FR-A740-03250 and -3610 . . . . .		A-13
	A.4.8 FR-A740-04320 and -04810 . . . . .		A-14
	A.4.9 FR-A740-05470, -06100 and -06830 . . . . .		A-15
	A.4.10 FR-A740-07700 and -08660 . . . . .		A-16
	A.4.11 FR-A740-09620, -10940 and -12120 . . . . .		A-17
	A.4.12 DC reactors . . . . .		A-18
	A.4.13 Panel cutting for the heatsink protrusion attachment . . . . .		A-23
	A.4.14 Operation panel FR-DU07 . . . . .		A-24
	A.4.15 Operation panel FR-PU07 . . . . .		A-24
	A.4.16 Parameter unit FR-PU04 . . . . .		A-25
A.5	Parameter list with instruction codes . . . . .		A-26



# 1 Product Checking and Part Identification

Unpack the inverter and check the capacity plate on the front cover and the rating plate on the inverter side face to ensure that the product agrees with your order and the inverter is intact.

## 1.1 Inverter Type

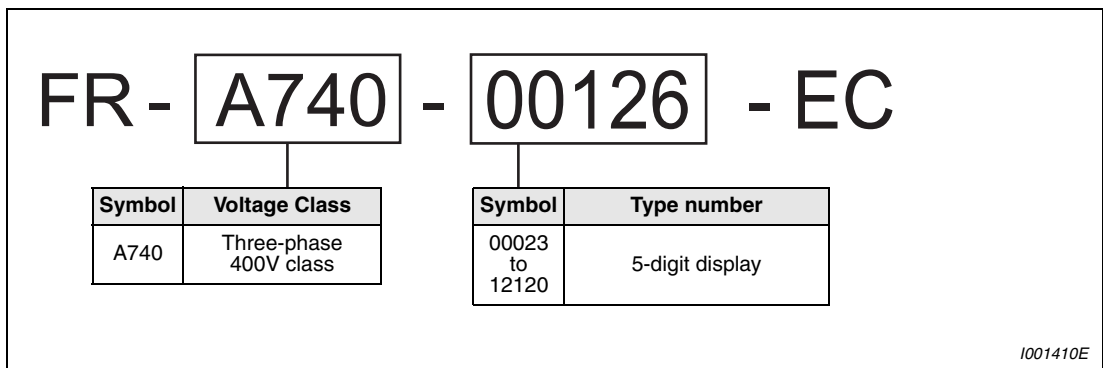

**Fig. 1-1:** Inverter type FR-A740 EC

# 1.2 Description of the Case

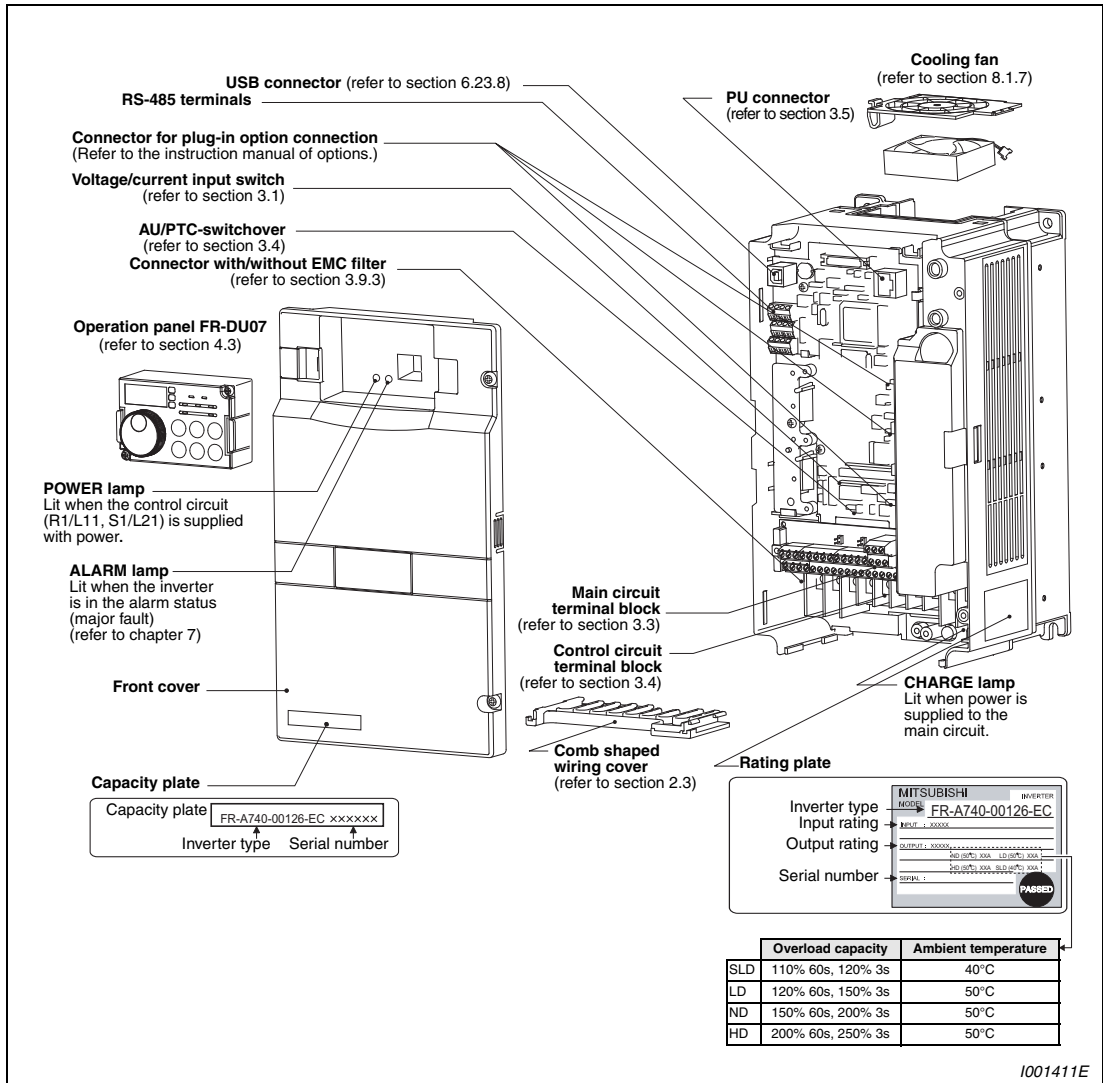

Fig. 1-2: Appearance and Structure

**NOTE**

For removal and reinstallation of covers, refer to section 2.2.

**Serial number**

The Serial number consists of one symbol, two characters indicating production year and month, and six characters indicating control number.

The last digit of the production year is indicated as the Year, and the Month is indicated by 1 to 9, X (October), Y (November), or Z (December).

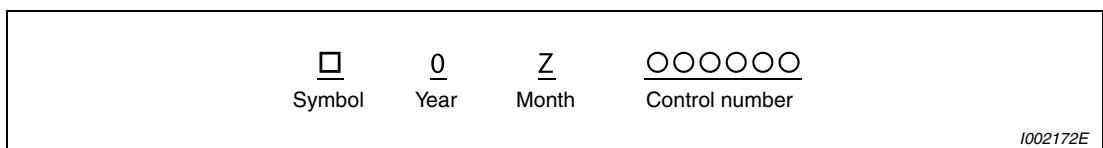

Fig. 1-3: Inverter serial number

## 1.2.1 Accessory

### Fan cover fixing screws

Capacity	Screw Size[mm]	Number
00083/00126	M3 × 35	1
00170 to 00380	M4 × 40	2
00470/00620	M4 × 50	1

**Tab. 1-1:** Fan cover fixing screws

#### NOTES

The fan cover fixing screws are not delivered with models 00620 or less.

For removal and reinstallation of the cooling fans, refer to section 8.1.7.

#### DC reactor

For models 01800 or more the supplied DC reactor has to be installed.

#### Eyebolts

Two eyebolts (M8) for hanging the inverter are delivered with the models 00770 to 06830.



#### Jumper

A jumper is delivered with the model 01800 (refer to section 3.3.1).





## 2 Installation

### 2.1 Removal and reinstallation of the operation panel

- ① Loosen the two screws on the operation panel. (These screws cannot be removed.)
- ② Push the left and right hooks of the operation panel and pull the operation panel toward you to remove.

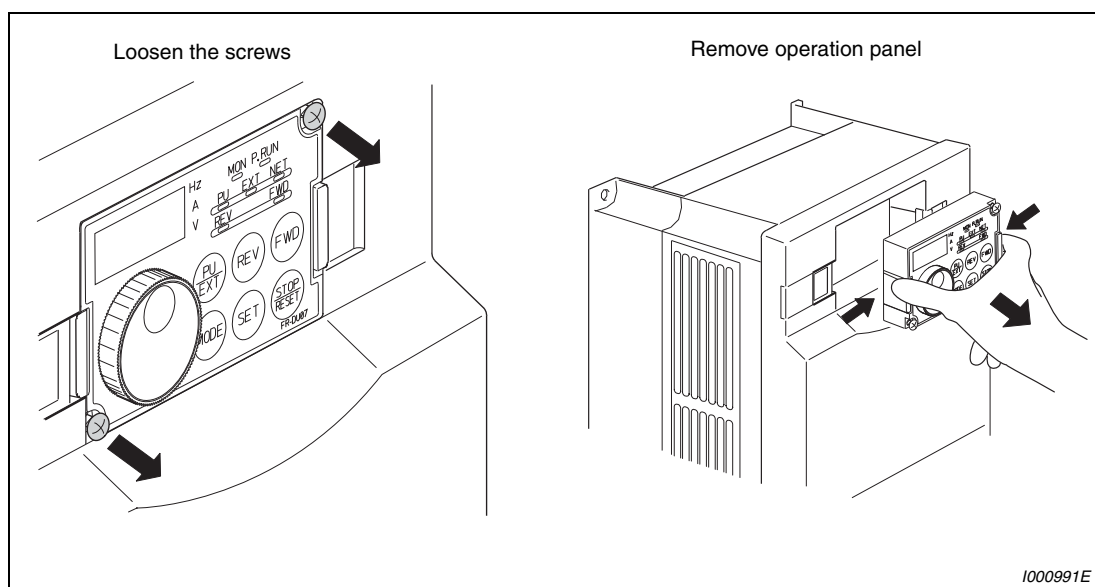

**Fig. 2-1:** Removal and reinstallation of the operation panel

- ③ When reinstalling the operation panel, insert it straight to reinstall securely and tighten the fixed screws of the operation panel.

## 2.2 Removal and reinstallation of the front cover

### 2.2.1 FR-A740-00023 to 00620-EC

#### Removal

- ① Loosen the installation screws of the front cover.
- ② Pull the front cover toward you to remove by pushing an installation hook using left fixed hooks as supports.

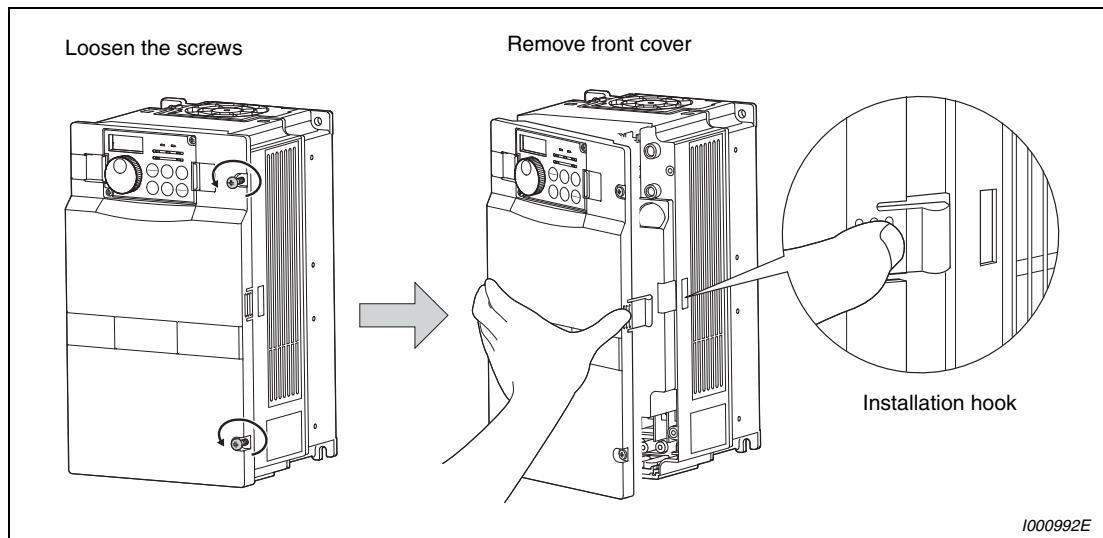

**Fig. 2-2:** Removal of the front cover

#### Reinstallation

- ① Insert the two fixed hooks on the left side of the front cover into the sockets of the inverter.
- ② Using the fixed hooks as supports, securely press the front cover against the inverter. (Although installation can be done with the operation panel mounted, make sure that a connector is securely fixed.)
- ③ Tighten the installation screws and fix the front cover.

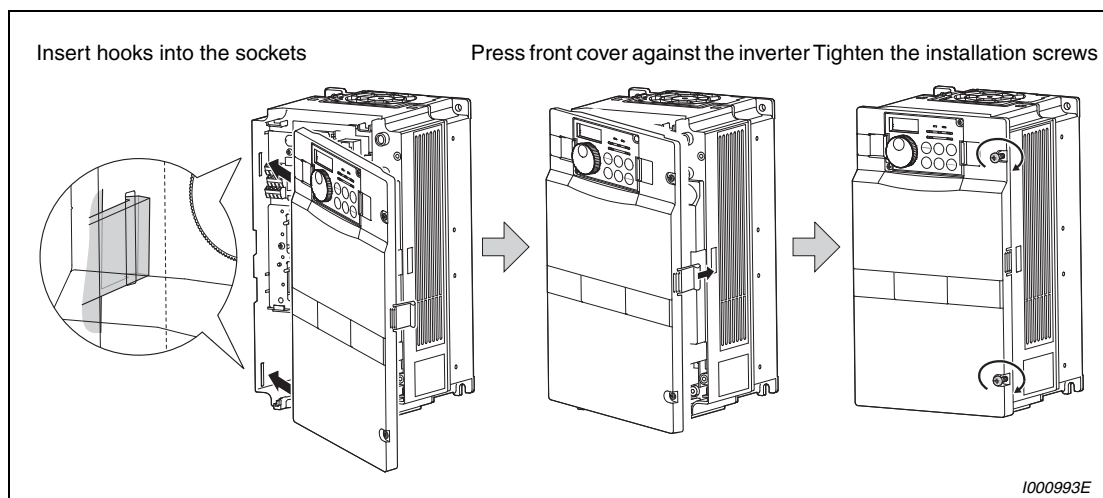
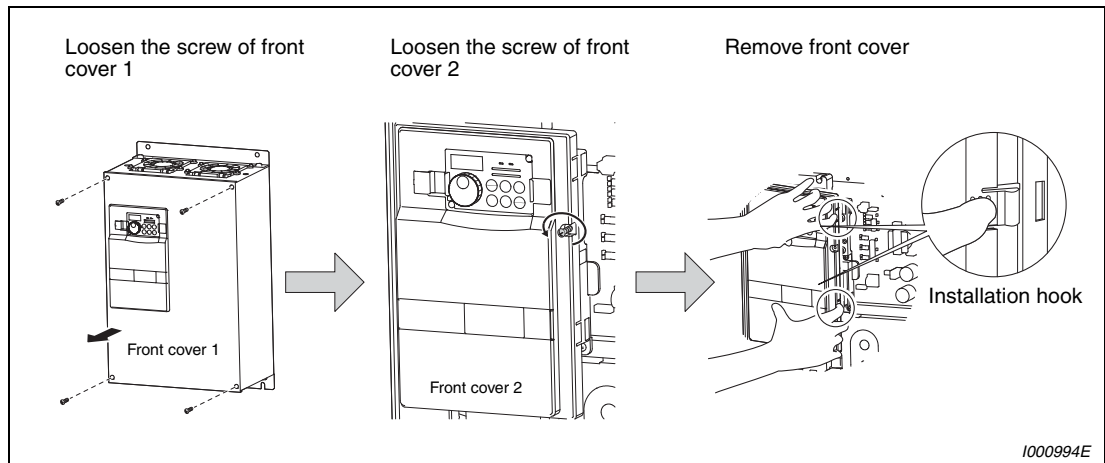

**Fig. 2-3:** Reinstallation of the front cover

## 2.2.2 FR-A740-00770 to 12120-EC

### Removal

- ① Loosen the installation screws of the front cover 1 to remove the front cover 1.
- ② Loosen the installation screws of the front cover 2.
- ③ Pull the front cover 2 toward you to remove by pushing an installation hook on the right side using left fixed hooks as supports.



**Fig. 2-4:** Removal of the front cover

### Reinstallation

- ① Insert the two fixed hooks on the left side of the front cover 2 into the sockets of the inverter.
- ② Using the fixed hooks as supports, securely press the front cover 2 against the inverter. (Although installation can be done with the operation panel mounted, make sure that a connector is securely fixed.)
- ③ Fix the front cover 2 with the installation screws.
- ④ Fix the front cover 1 with the installation screws.

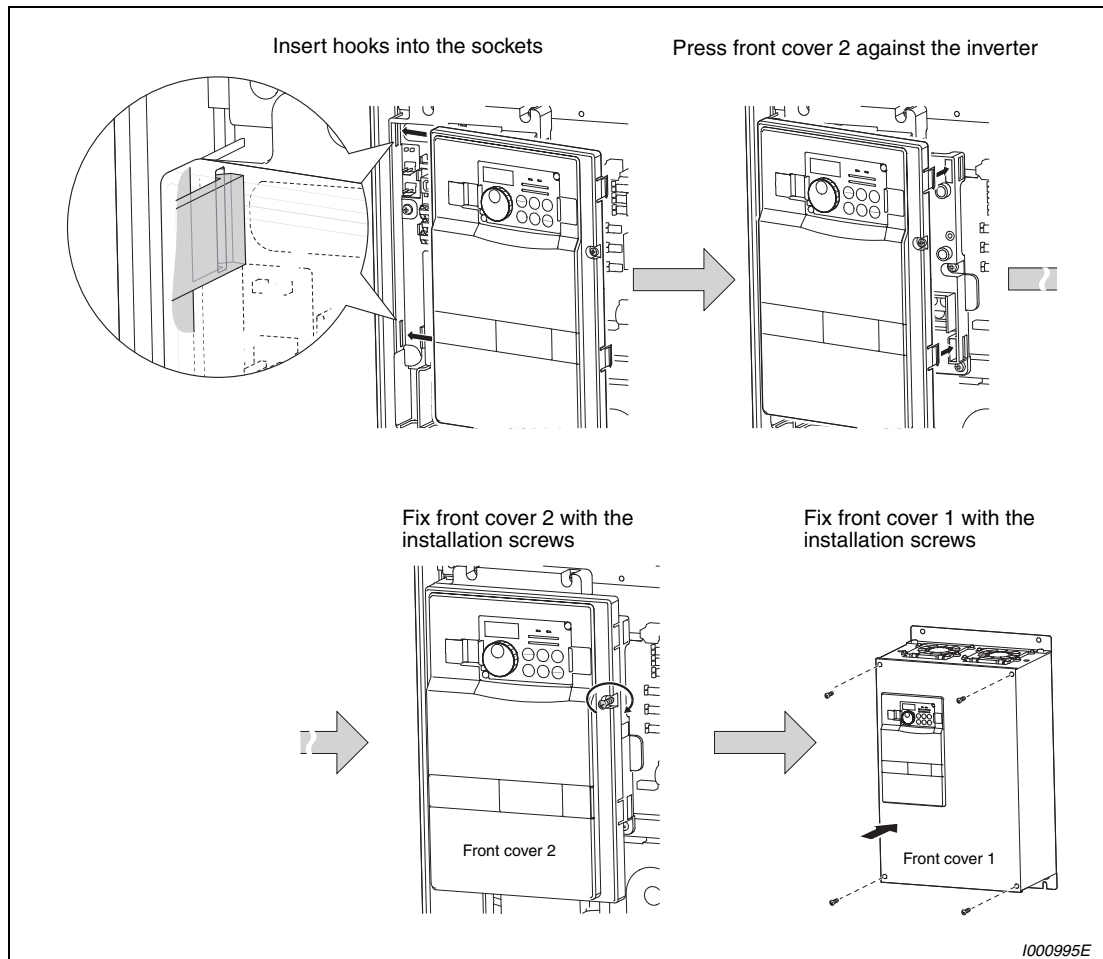

**Fig. 2-5:** Reinstallation of the front cover

### NOTES

For the FR-A740-04320 or more, the front cover 1 is separated into two parts.

Fully make sure that the front cover has been reinstalled securely. Always tighten the installation screws of the front cover.

The same serial number is printed on the capacity plate of the front cover and the rating plate of the inverter. Before reinstalling the front cover, check the serial numbers to ensure that the cover removed is reinstalled to the inverter from where it was removed.



## 2.3 Mounting

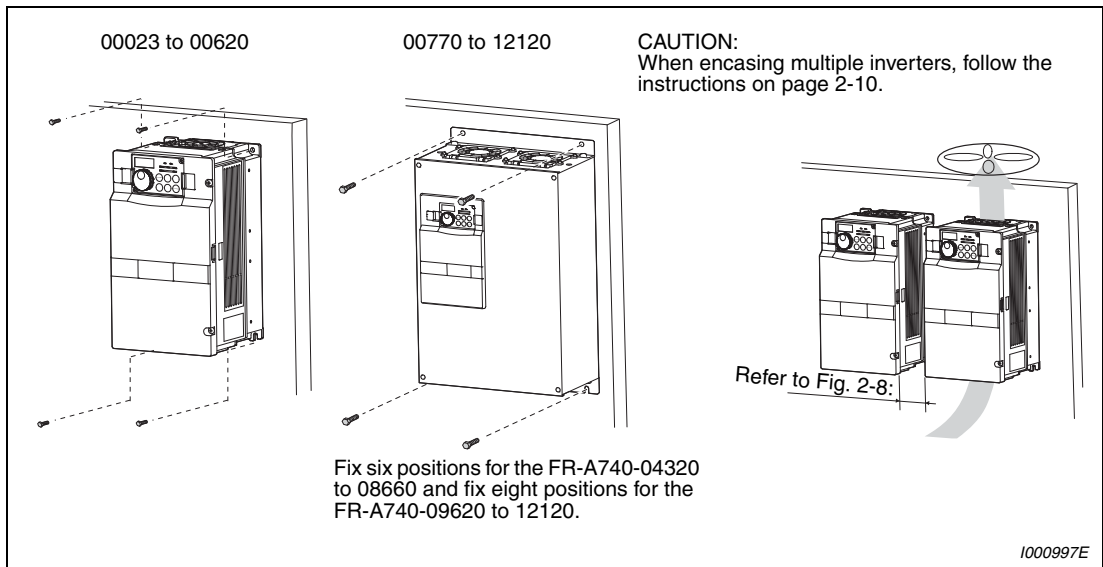

**Fig. 2-6:** Installation on the panel

The inverter consists of precision mechanical and electronic parts. Never install or handle it in any of the following conditions as doing so could cause an operation fault or failure.

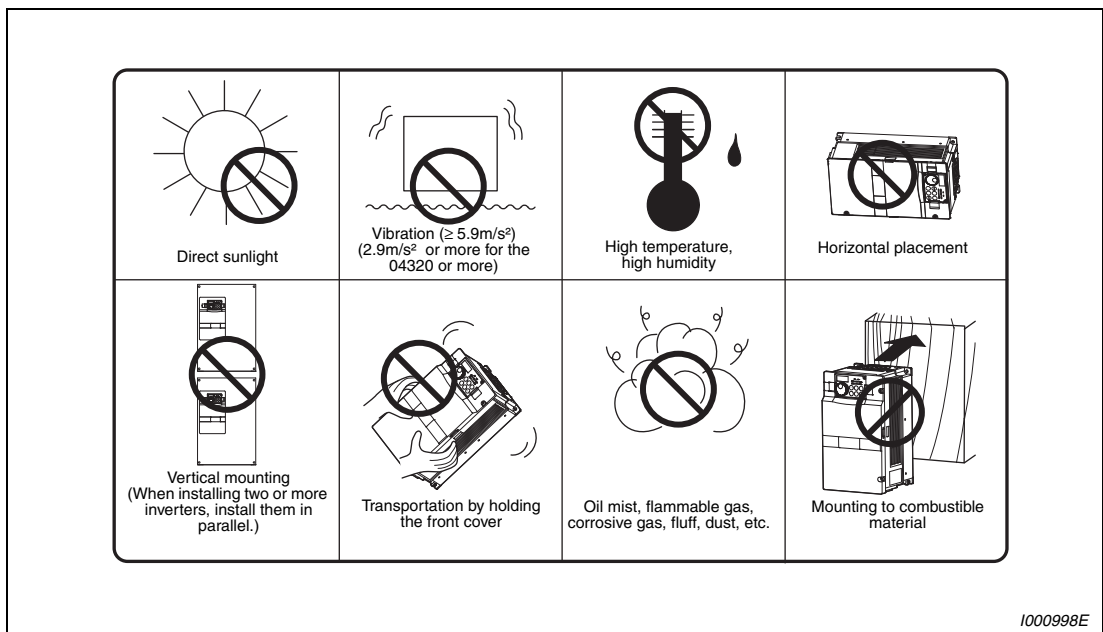

**Fig. 2-7:** Conditions, that could cause an operation fault or failure

## 2.4 Enclosure design

When an inverter enclosure is to be designed and manufactured, heat generated by contained equipment, etc., the environment of an operating place, and others must be fully considered to determine the enclosure structure, size and equipment layout. The inverter unit uses many semiconductor devices. To ensure higher reliability and long period of operation, operate the inverter in the ambient environment that completely satisfies the equipment specifications.

### 2.4.1 Inverter installation environment

As the inverter installation environment should satisfy the standard specifications indicated in the following table, operation in any place that does not meet these conditions not only deteriorates the performance and life of the inverter, but also causes a failure. Refer to the following points and take adequate measures.

Operating Condition		FR-A740
Ambient temperature	LD (150%), ND (200%, initial value) and HD (250%)	-10°C to +50°C (non-freezing)
	SLD (120%)	-10°C to +40°C (non-freezing)
Ambient humidity		90% RH or less (non-condensing)
Atmosphere		Indoors (free from corrosive gas, flammable gas, oil mist, dust and dirt)
Maximum altitude		1000m or less
Vibration		5.9m/s <sup>2</sup> or less (2.9m/s <sup>2</sup> or less for the 04320 or more.)

**Tab. 2-1:** Environmental standard specifications of inverter

#### Temperature

The permissible ambient temperature of the inverter is between -10 and +50°C (when LD, ND or HD is set) or -10 and +40°C (when SLD is set). Always operate the inverter within this temperature range. Operation outside this range will considerably shorten the service lives of the semiconductors, parts, capacitors and others. Take the following measures so that the ambient temperature of the inverter falls within the specified range.

- Measures against high temperature
  - Use a forced ventilation system or similar cooling system. (Refer to page 2-9.)
  - Install the enclosure in an air-conditioned electrical chamber.
  - Block direct sunlight.
  - Provide a shield or similar plate to avoid direct exposure to the radiated heat and wind of a heat source.
  - Ventilate the area around the enclosure well.
- Measures against low temperature
  - Provide a space heater in the enclosure.
  - Do not power off the inverter. (Keep the start signal of the inverter off.)
- Sudden temperature changes
  - Select an installation place where temperature does not change suddenly.
  - Avoid installing the inverter near the air outlet of an air conditioner.
  - If temperature changes are caused by opening/closing of a door, install the inverter away from the door.

### Humidity

Normally operate the inverter within the 45 to 90% range of the ambient humidity. Too high humidity will pose problems of reduced insulation and metal corrosion. On the other hand, too low humidity may produce a spatial electrical breakdown. The insulation distance specified in JEM1103 "Control Equipment Insulator" is defined as humidity 45 to 85%.

- Measures against high humidity

- Make the enclosure enclosed, and provide it with a hygroscopic agent.
- Take dry air into the enclosure from outside.
- Provide a space heater in the enclosure.

- Measures against low humidity

What is important in fitting or inspection of the unit in this status is to discharge your body (static electricity) beforehand and keep your body from contact with the parts and patterns, besides blowing air of proper humidity into the enclosure from outside.

- Measures against condensation

Condensation may occur if frequent operation stops change the in-enclosure temperature suddenly or if the outside air temperature changes suddenly. Condensation causes such faults as reduced insulation and corrosion.

- Take the measures against high humidity.
- Do not power off the inverter. (Keep the start signal of the inverter off.)

### Dust, dirt, oil mist

Dust and dirt will cause such faults as poor contact of contact points, reduced insulation or reduced cooling effect due to moisture absorption of accumulated dust and dirt, and in-enclosure temperature rise due to clogged filter.

In the atmosphere where conductive powder floats, dust and dirt will cause such faults as malfunction, deteriorated insulation and short circuit in a short time.

Since oil mist will cause similar conditions, it is necessary to take adequate measures.

- Measures against dust, dirt, oil mist

- Place in a totally enclosed enclosure.  
Take measures if the in-enclosure temperature rises. (Refer to page 2-9.)
- Purge air.  
Pump clean air from outside to make the in-enclosure pressure higher than the outside-air pressure.

### Corrosive gas, salt damage

If the inverter is exposed to corrosive gas or to salt near a beach, the printed board patterns and parts will corrode or the relays and switches will result in poor contact. In such places, take the measures against dust, dirt, oil mist.

**Explosive, flammable gases**

As the inverter is non-explosion proof, it must be contained in an explosion proof enclosure. In places where explosion may be caused by explosive gas, dust or dirt, an enclosure cannot be used unless it structurally complies with the guidelines and has passed the specified tests. This makes the enclosure itself expensive (including the test charges). The best way is to avoid installation in such places and install the inverter in a non-hazardous place.

**Highland**

Use the inverter at the altitude of within 1000m.

If it is used at a higher place, it is likely that thin air will reduce the cooling effect and low air pressure will deteriorate dielectric strength.

**Vibration, impact**

The vibration resistance of the inverter is up to  $5.9\text{m/s}^2$  ( $2.9\text{m/s}^2$  for the 04320 or more) at 10 to 55Hz frequency and 1mm amplitude as specified in JIS C 60068-2-6.

Vibration or impact, if less than the specified value, applied for a long time may make the mechanism loose or cause poor contact to the connectors.

Especially when impact is imposed repeatedly, caution must be taken as the part pins are likely to break.

**● Countermeasures**

- Provide the enclosure with rubber vibration isolators.
- Strengthen the structure to prevent the enclosure from resonance.
- Install the enclosure away from sources of vibration.

**Cooling system types for inverter enclosure**

From the enclosure that contains the inverter, the heat of the inverter and other equipment (transformers, lamps, resistors, etc.) and the incoming heat such as direct sunlight must be dissipated to keep the in-enclosure temperature lower than the permissible temperatures of the in-enclosure equipment including the inverter.

The cooling systems are classified as follows in terms of the cooling calculation method.

- Cooling by natural heat dissipation from the enclosure surface (Totally enclosed type)
- Cooling by heat sink (Aluminium fin, etc.)
- Cooling by ventilation (Forced ventilation type, pipe ventilation type)
- Cooling by heat exchanger or cooler (Heat pipe, cooler, etc.)

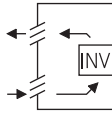
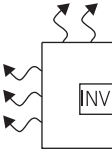
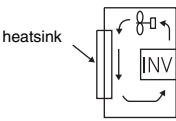
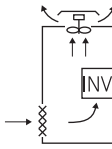
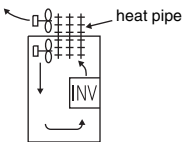
Cooling System		Enclosure Structure	Comment
Natural cooling	Natural ventilation (Enclosed, open type)	 <p style="text-align: center;">1001000E</p>	Low in cost and generally used, but the enclosure size increases as the inverter capacity increases. For relatively small capacities.
	Natural ventilation (Totally enclosed type)	 <p style="text-align: center;">1001001E</p>	Being a totally enclosed type, the most appropriate for hostile environment having dust, dirt, oil mist, etc. The enclosure size increases depending on the inverter capacity.
Forced cooling	Heatsink cooling	 <p style="text-align: center;">1001002E</p>	Having restrictions on the heatsink mounting position and area, and designed for relative small capacities.
	Forced ventilation	 <p style="text-align: center;">1001003E</p>	For general indoor installation. Appropriate for enclosure downsizing and cost reduction, and often used.
	Heat pipe	 <p style="text-align: center;">1001004E</p>	Totally enclosed type for enclosure downsizing.

**Tab. 2-2:** Cooling system types for inverter enclosure

## 2.4.2 Inverter placement

### Clearances around the inverter

Always observe the specified minimum clearances to ensure good heat dissipation and adequate accessibility of the frequency inverter for servicing.

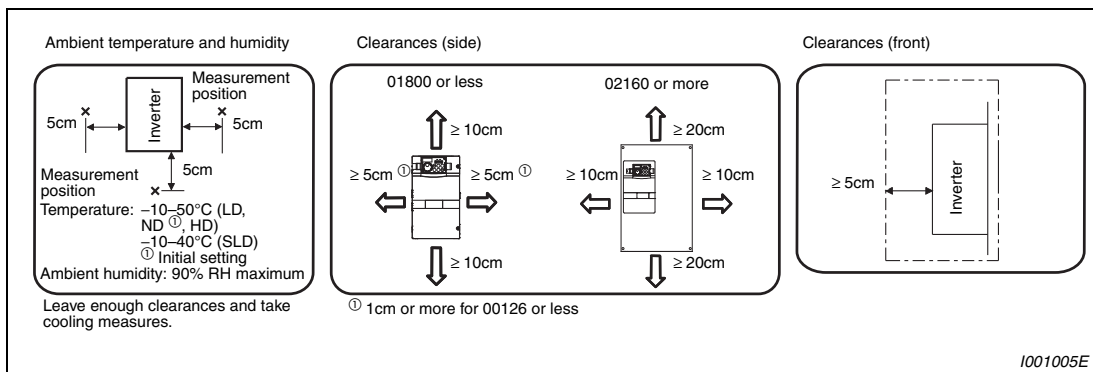

Fig. 2-8: Clearances

**NOTE**

For replacing the cooling fan of the 04320 or more, 30cm of space is necessary in front of the inverter. Refer to section 8.1.7 for fan replacement.

### Inverter mounting orientation

Mount the inverter on a wall as specified. Do not mount it horizontally or any other way.

### Above the inverter

Heat is blown up from inside the inverter by the small fan built in the unit. Any equipment placed above the inverter should be heat resistant.

### Arrangement of multiple inverters

When multiple inverters are placed in the same enclosure, generally arrange them horizontally as shown in the figure (a). When it is inevitable to arrange them vertically to minimize space, take such measures as to provide guides since heat from the bottom inverters can increase the temperatures in the top inverters, causing inverter failures.

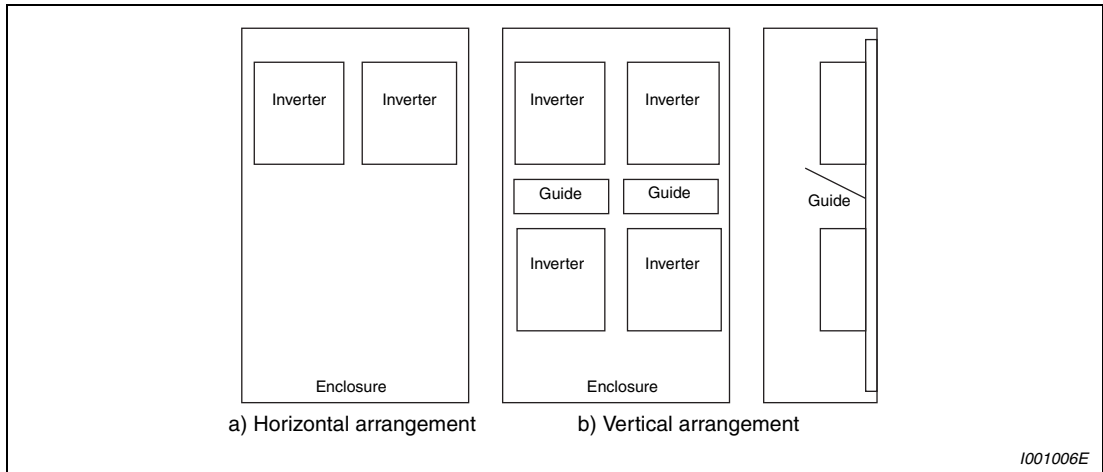

Fig. 2-9: Arrangement of multiple inverters

**NOTE**

When mounting multiple inverters, fully take caution not to make the ambient temperature of the inverter higher than the permissible value by providing ventilation and increasing the enclosure size.

### Placement of ventilation fan and inverter

Heat generated in the inverter is blown up from the bottom of the unit as warm air by the cooling fan. When installing a ventilation fan for that heat, determine the place of ventilation fan installation after fully considering an air flow. (Air passes through areas of low resistance. Make an airway and airflow plates to expose the inverter to cool air.)

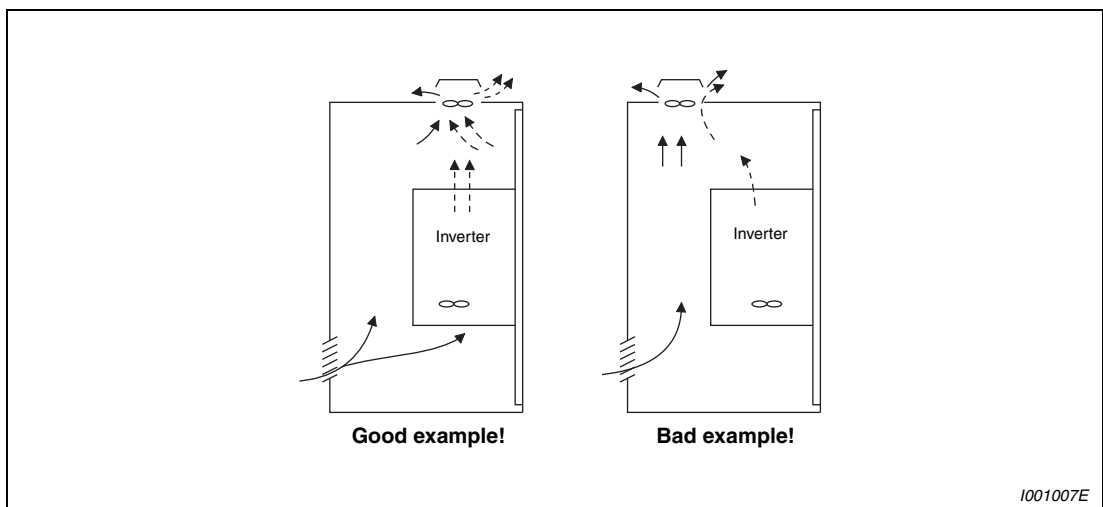

Fig. 2-10: Placement of ventilation fan and inverter

### 2.4.3 Heatsink protrusion attachment (FR-A7CN)

When encasing the inverter in an enclosure, the generated heat amount in an enclosure can be greatly reduced by installing the heatsink portion of the inverter outside the enclosure. When installing the inverter in a compact enclosure, etc., this installation method is recommended.

For the FR-A740-00023 to 03610, a heatsink can be protruded outside the enclosure using a heatsink protrusion attachment (FR-A7CN). For a panel cut dimension drawing and an installation procedure of the heatsink protrusion attachment (FR-A7CN) to the inverter, refer to a manual of "heatsink protrusion attachment".

For the panel cut dimensions of the inverters FR-A740-04320 or more refer to Fig. A-17 in the appendix.

#### Shift and removal of a rear side installation frame

- FR-A740-04320 to 06830

One installation frame is attached to each of the upper and lower part of the inverter. Change the position of the rear side installation frame on the upper and lower side of the inverter to the frontside as shown below. When changing the installation frames, make sure that the installation orientation is correct.

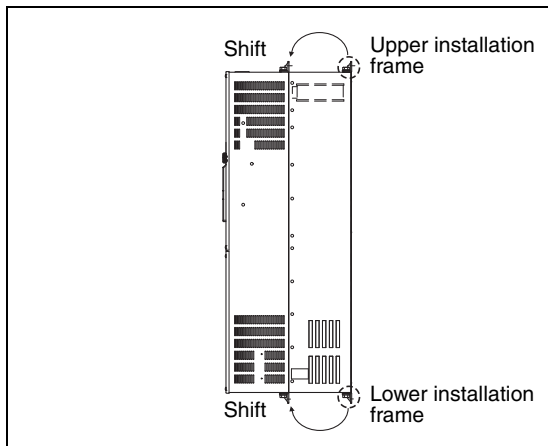
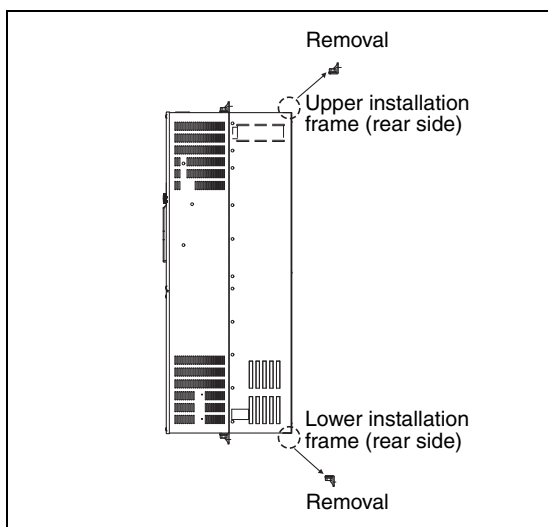

**Fig. 2-11:**  
Shifting the rear side installation frame (04320 to 06830)

1001381E

- FR-A740-07700 or more

Two installation frames each are attached to the upper and lower part of the inverter. Remove the rear side installation frame on the upper and lower side of the inverter as shown below.



**Fig. 2-12:**  
Removing the rear side installation frame (07700 or more)

1001382E



**Installation of the inverter**

Push the inverter heatsink portion outside the enclosure and fix the enclosure and inverter with upper and lower installation frame.

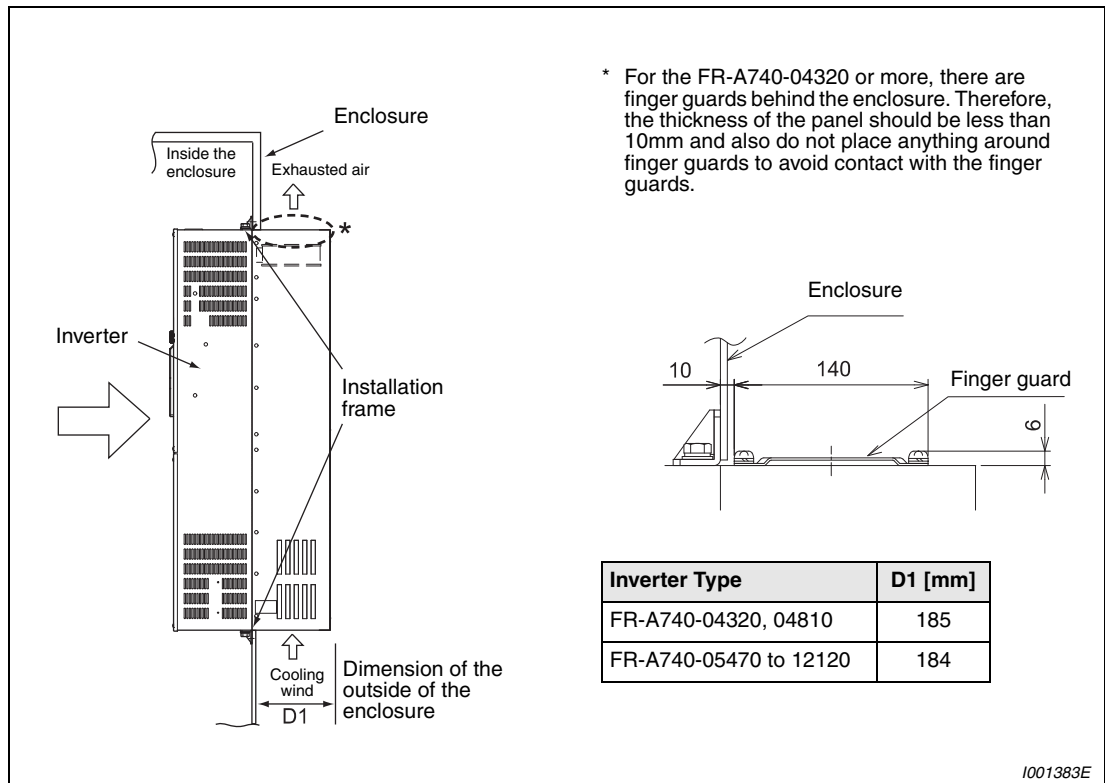

**Fig. 2-13: Installation of the inverter**



**CAUTION:**

- **Having a cooling fan, the cooling section which comes out of the enclosure can not be used in the environment of waterdrops, oil, mist, dust, etc.**
- **Be careful not to drop screws, dust etc. into the inverter and cooling fan section.**



# 3 Wiring

## 3.1 Inverter and peripheral devices

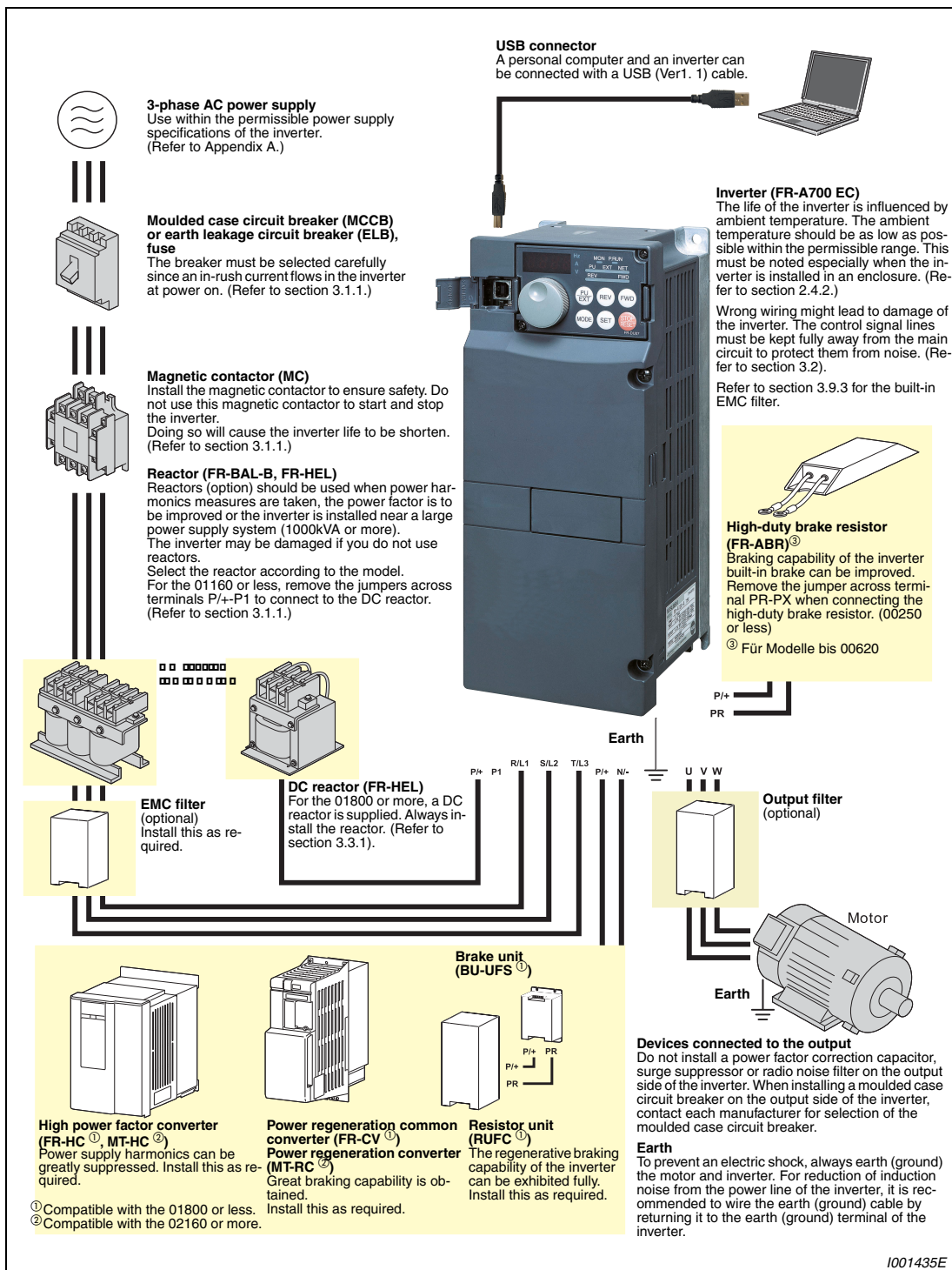

Fig. 3-1: System configuration overview

**NOTES**

Do not install a power factor correction capacitor or surge suppressor on the inverter output side. This will cause the inverter to trip or the capacitor and surge suppressor to be damaged. If any of the above devices are connected, immediately remove them.

**Electromagnetic Compatibility**

Operation of the frequency inverter can cause electromagnetic interference in the input and output that can be propagated by cable (via the power input lines), by wireless radiation to nearby equipment (e.g. AM radios) or via data and signal lines.

Activate the integrated EMC filter (and an additional optional filter if present) to reduce air propagated interference on the input side of the inverter. Use AC or DC reactors to reduce line propagated noise (harmonics). Use shielded motor power lines to reduce output noise (refer also to section 3.9 Electromagnetic Compatibility).

Refer to the instruction manual of each option and peripheral devices for details of peripheral devices.

### 3.1.1 Peripheral devices

Check the motor capacity of the inverter you purchased. Appropriate peripheral devices must be selected according to the capacity. Refer to the following list and prepare appropriate peripheral devices:

Motor Output [kW] <sup>①</sup>	Applicable Inverter Type	Breaker Selection <sup>②④</sup>			Input Side Magnetic Contactor <sup>③</sup>	
		Reactor connection		With commercial power-supply operation	Reactor connection	
		Without	With		Without	With
0.4	FR-A740-00023-EC	NF32 xx 3P 6 A	NF32 xx 3P 4 A	NF32 xx 3P 6 A	S-N10	S-N10
0.75	FR-A740-00038-EC	NF32 xx 3P 10 A	NF32 xx 3P 6 A	NF32 xx 3P 10 A	S-N10	S-N10
1.5	FR-A740-00052-EC	NF32 xx 3P 10 A	NF32 xx 3P 10 A	NF32 xx 3P 10 A	S-N10	S-N10
2.2	FR-A740-00083-EC	NF32 xx 3P 16 A	NF32 xx 3P 10 A	NF32 xx 3P 16 A	S-N10	S-N10
3.7	FR-A740-00126-EC	NF32 xx 3P 20 A	NF32 xx 3P 16 A	NF32 xx 3P 20 A	S-N20	S-N11
5.5	FR-A740-00170-EC	NF32 xx 3P 32 A	NF32 xx 3P 25 A	NF32 xx 3P 32 A	S-N20	S-N20
7.5	FR-A740-00250-EC	NF63 xx 3P 40 A	NF32 xx 3P 32 A	NF63 xx 3P 40 A	S-N20	S-N20
11	FR-A740-00310-EC	NF63 xx 3P 50 A	NF63 xx 3P 40 A	NF63 xx 3P 50 A	S-N25	S-N21
15	FR-A740-00380-EC	NF63 xx 3P 63 A	NF63 xx 3P 50 A	NF63 xx 3P 63 A	S-N35	S-N25
18.5	FR-A740-00470-EC	NF125 xx 3P 100 A	NF63 xx 3P 63 A	NF125 xx 3P 100 A	S-N35	S-N25
22	FR-A740-00620-EC	NF125 xx 3P 100 A	NF125 xx 3P 100 A	NF125 xx 3P 100 A	S-N50	S-N35
30	FR-A740-00770-EC	NF125 xx 3P 125 A	NF125 xx 3P 100 A	NF125 xx 3P 125 A	S-N65	S-N50
37	FR-A740-00930-EC	NF160 xx 3P 163 A	NF125 xx 3P 125 A	NF160 xx 3P 163 A	S-N80	S-N65
45	FR-A740-01160-EC	NF250 xx 3P 250 A	NF160 xx 3P 163 A	NF250 xx 3P 250 A	S-N80	S-N80
55	FR-A740-01800-EC <sup>⑤</sup>	—	NF250 xx 3P 250 A	NF250 xx 3P 400 A	—	S-N95
75	FR-A740-02160-EC <sup>⑤</sup>	—	NF250 xx 3P 250 A	NF250 xx 3P 400 A	—	S-N150
90	FR-A740-02600-EC <sup>⑤</sup>	—	NF250 xx 3P 250 A	NF400 xx 3P 400 A	—	S-N180
110	FR-A740-03250-EC <sup>⑤</sup>	—	NF400 xx 3P 400 A	NF400 xx 3P 400 A	—	S-N220
132	FR-A740-03610-EC <sup>⑤</sup>	—	NF400 xx 3P 400 A	NF630 xx 3P 500 A	—	S-N300
160	FR-A740-04320-EC <sup>⑤</sup>	—	NF400 xx 3P 400 A	NF630 xx 3P 500 A	—	S-N300
185	FR-A740-04810-EC <sup>⑤</sup>	—	NF630 xx 3P 500 A	NF630 xx 3P 600 A	—	S-N400
220	FR-A740-05470-EC <sup>⑤</sup>	—	NF630 xx 3P 600 A	NF630 xx 3P 600 A	—	S-N600
250	FR-A740-06100-EC <sup>⑤</sup>	—	NF630 xx 3P 600 A	NF800 xx 3P 800 A	—	S-N600
280	FR-A740-06830-EC <sup>⑤</sup>	—	NF800 xx 3P 700 A	NF800 xx 3P 800 A	—	S-N600
315	FR-A740-07700-EC <sup>⑤</sup>	—	NF800 xx 3P 800 A	NF800 xx 3P 800 A	—	S-N600
355	FR-A740-08660-EC <sup>⑤</sup>	—	NF1000 xx 3P 900 A	NF1000 xx 3P 1000 A	—	S-N800
400	FR-A740-09620-EC <sup>⑤</sup>	—	NF1000 xx 3P 1000 A	NF1000 xx 3P 1000 A	—	1000 A Rated current
450	FR-A740-10940-EC <sup>⑤</sup>	—	NF1250 xx 3P 1200 A	NF1250 xx 3P 1200 A	—	1000 A Rated current
500	FR-A740-12120-EC <sup>⑤</sup>	—	NF1600 xx 3P 1500 A	NF1600 xx 3P 1600 A	—	1200 A Rated current

**Tab. 3-1:** Breakers and contactors

- ① Selections for use of the Mitsubishi 4-pole standard motor with power supply voltage of 400V AC 50Hz.
- ② Select the MCCB according to the inverter power supply capacity. Install one MCCB per inverter.  
The places with "xx" refer to the breaking capacity in case of short circuit. The correct selection must be done depending on the design of the power input wiring.

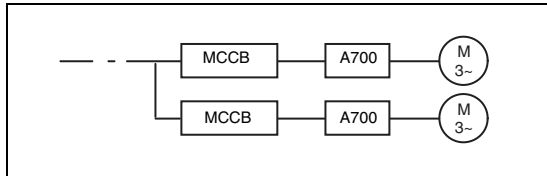

**Fig. 3-2:**  
*Installation of the breakers*

1001332E

- ③ Magnetic contactor is selected based on the AC-1 class. The electrical durability of magnetic contactor is 500,000 times. When the magnetic contactor is used for emergency stop during motor driving, the electrical durability is 25 times.  
When using the MC for emergency stop during motor driving or using on the motor side during commercial-power supply operation, select the MC with class AC-3 rated current for the motor rated current.
- ④ When the breaker on the inverter primary side trips, check for the wiring fault (short circuit), damage to internal parts of the inverter, etc. Identify the cause of the trip, then remove the cause and power on the breaker.
- ⑤ The supplied DC reactor has to be installed.

### 3.2 Terminal connection diagram

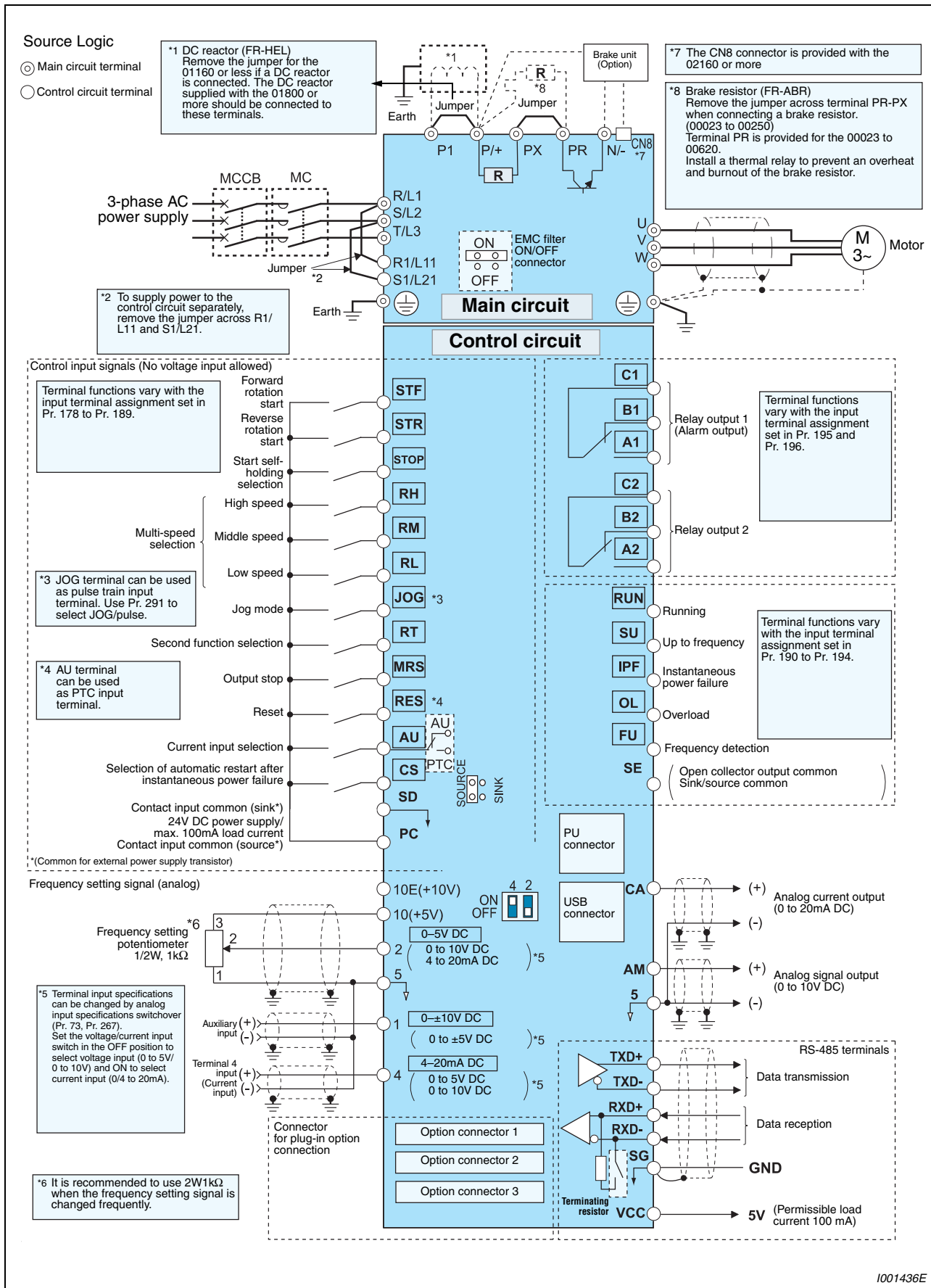

Fig. 3-3: Terminal connection diagram of the inverter

**NOTES**

To prevent a malfunction due to noise, keep the signal cables more than 10cm away from the power cables.

After wiring, wire offcuts must not be left in the inverter.

Wire offcuts can cause an alarm, failure or malfunction. Always keep the inverter clean.

When drilling mounting holes in an enclosure etc., take care not to allow chips and other foreign matter to enter the inverter.

Set the voltage/current input switch in right position. Different setting may cause a fault, failure or malfunction



## 3.3 Main circuit connection

### 3.3.1 Specification of main circuit terminal

Terminal	Name	Description
L1, L2, L3	AC power input	Connect to the commercial power supply (380–480V AC, 50/60Hz; for 01800 or more: 380–500V AC) Keep these terminals open when using the high power factor converter (FR-HC, MT-HC) or power regeneration common converter (FR-CV).
U, V, W	Inverter output	Voltage output of the inverter (3 ~, 0V–power supply voltage, 0.2–400 Hz)
L11, L21	Power supply for control circuit	Connected to the AC power supply terminals L1 and L2. To retain the alarm display and alarm output or when using the high power factor converter (FR-HC, MT-HC) or power regeneration common converter (FR-CV), remove the jumpers from terminals L1-L11 and L2-L21 and apply external power to these terminals. Do not turn off the power supply for control circuit (L11, L21) with the main circuit power (L1, L2, L3) on. Doing so may damage the inverter. The circuit should be configured so that the main circuit power (L1, L2, L3) is also turned off when the power supply for control circuit (L11, L21) is off. 00380 or less: 60VA, 00470 or more: 80VA
P/+, PR	Brake resistor connection (00620 or less)	Remove the jumper from terminals PR-PX (00250 or less) and connect an optional brake resistor (FR-ABR) across terminals P/+ - PR. For the 00620 or less, connecting the resistor further provides regenerative braking power.
P/+, N/-	Brake unit connection	Connect the brake unit (FR-BU, BU and MT-BU5), power regeneration common converter (FR-CV), high power factor converter (FR-HC and MT-HC) or power regeneration converter (MTRC).
P/+, P1	DC reactor connection	For the 01160 or less, remove the jumper across terminals P/+ - P1 and connect the DC reactor. (As a DC reactor is supplied with the 01800 or more as standard, be sure to connect the DC reactor. ①)
PR, PX	Built-in brake circuit connection	When the jumper is connected across terminals PX-PR (initial status), the built-in brake circuit is valid. (Provided for the 00250 or less.)
	PE	For earthing the inverter chassis. Must be earthed.

**Tab. 3-2:** Specification of main circuit terminal

- ① Connecting a DC reactor to the 01800
- When using the inverter for LD or SLD rating, always connect the supplied DC reactor.
  - To improve power factor and suppress harmonics with a reactor when using the inverter for ND or HD rating, connect the supplied DC reactor.
  - It is not necessary to connect the supplied DC reactor for operation other than the above. When not connecting the supplied DC reactor, connect a supplied jumper across terminals P/+ and P1.
  - The inverter operates only when either a DC reactor or jumper is connected.

#### NOTE

When connecting a dedicated brake resistor (FR-ABR) and brake unit (FR-BU, BU) remove jumpers across terminals PR-PX (00250 or less).

### 3.3.2 Terminal layout and wiring

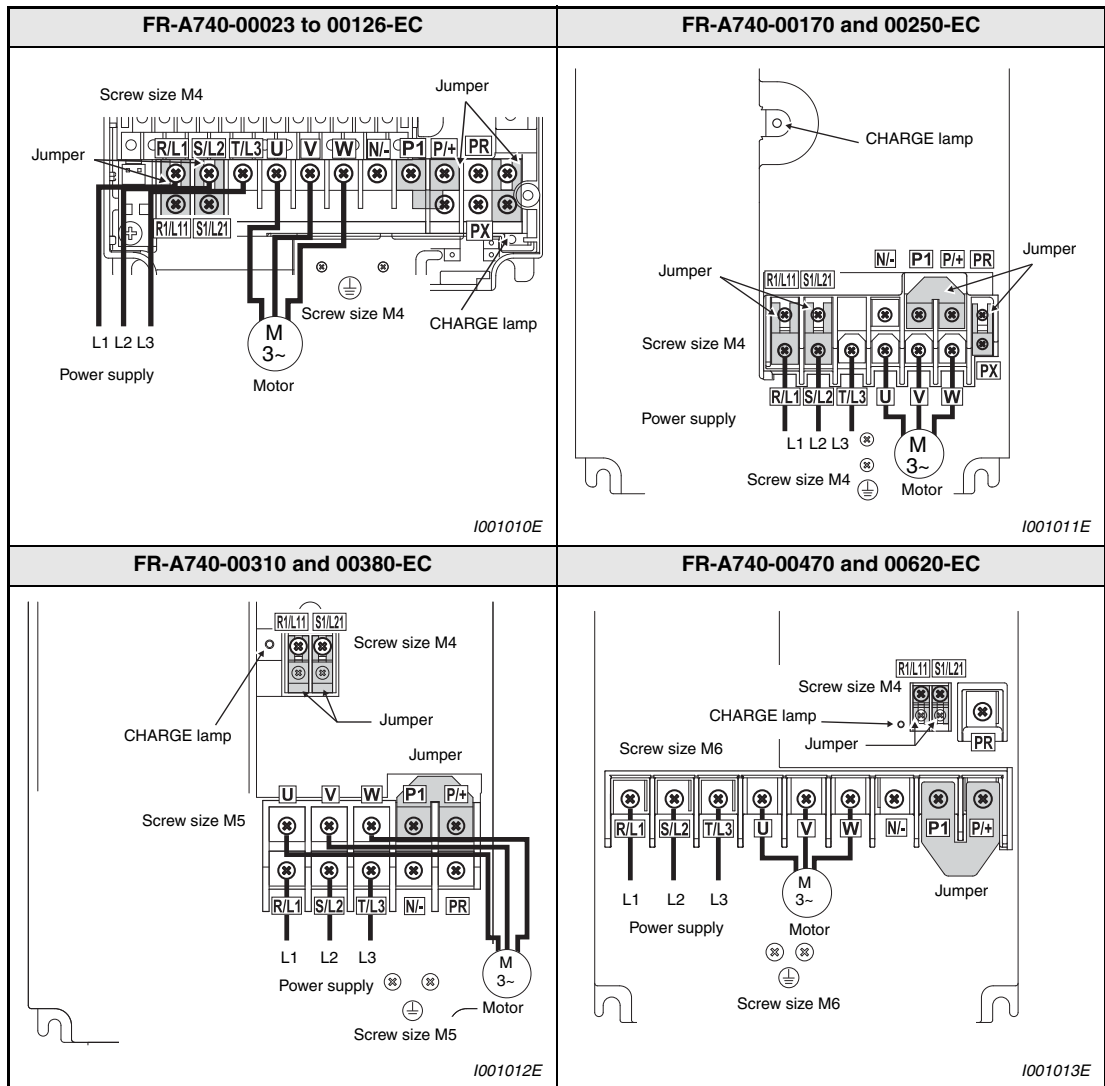

Tab. 3-3: Terminal layout and wiring (1)

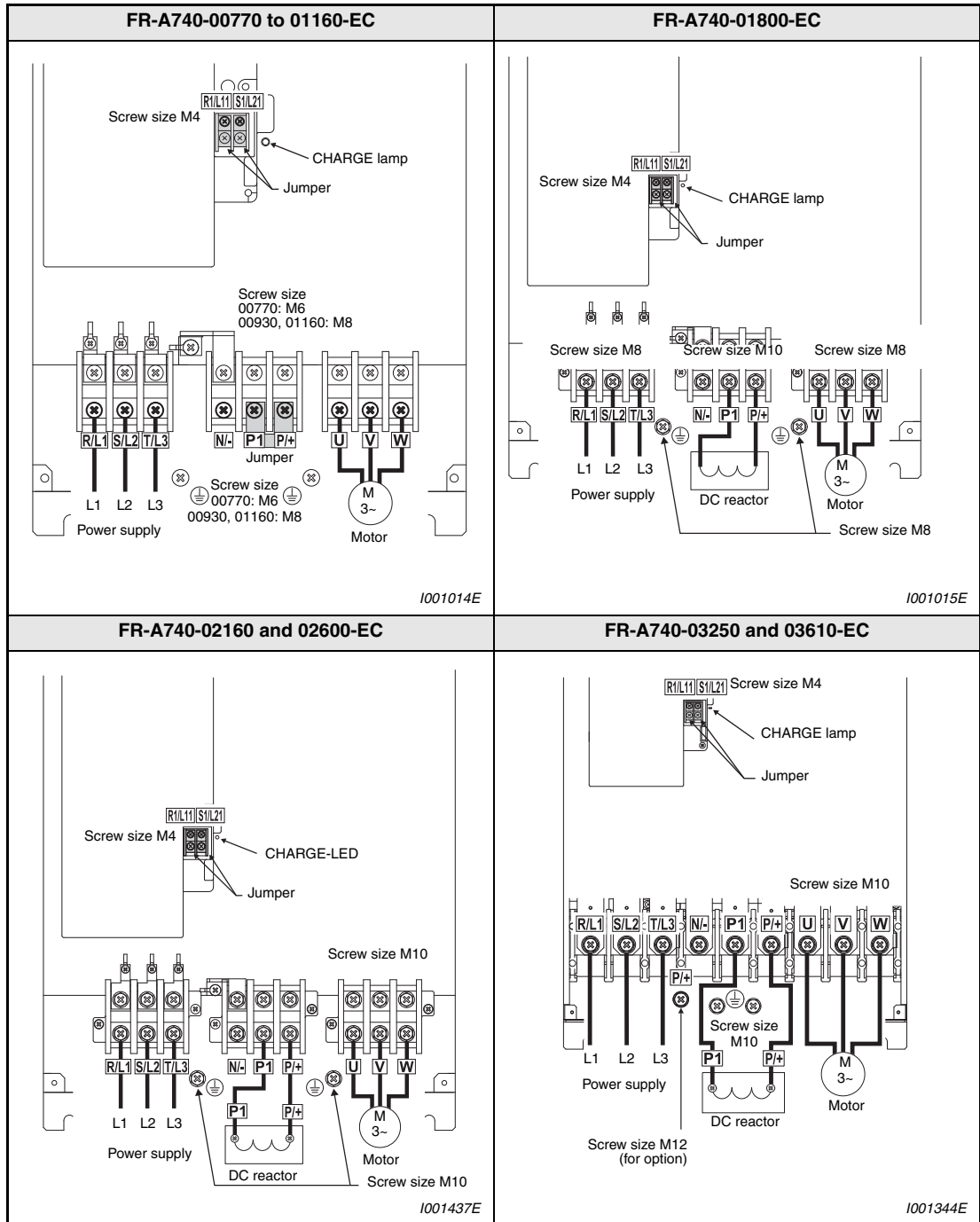

Tab. 3-3: Terminal layout and wiring (2)

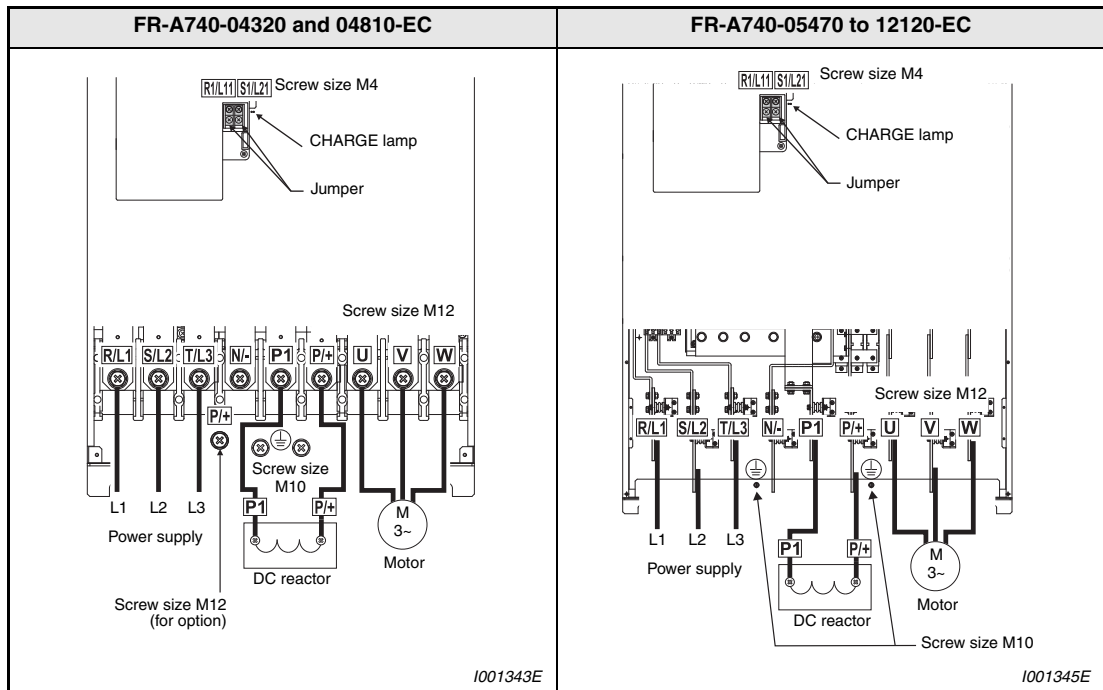

**Tab. 3-3:** Terminal layout and wiring (3)



**CAUTION:**

- **The power supply cables must be connected to R/L1, S/L2, T/L3. Never connect the power cable to the U, V, W of the inverter. Doing so will damage the inverter. (Phase sequence needs not to be matched.)**
- **Connect the motor to U, V, W. At this time, turning on the forward rotation switch (signal) rotates the motor in the counter clockwise direction when viewed from the motor shaft.**

**Connection to the conductors**

When wiring the inverter main circuit conductor of the 05470 or more, tighten a nut from the right side of the conductor. When wiring two wires, place wires on both sides of the conductor. (Refer to the drawing below.) For wiring, use bolts (nuts) provided with the inverter.

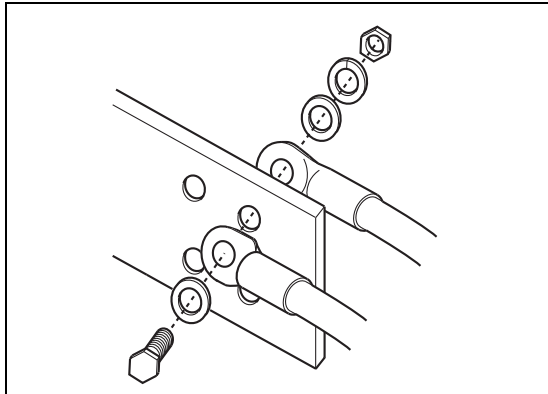
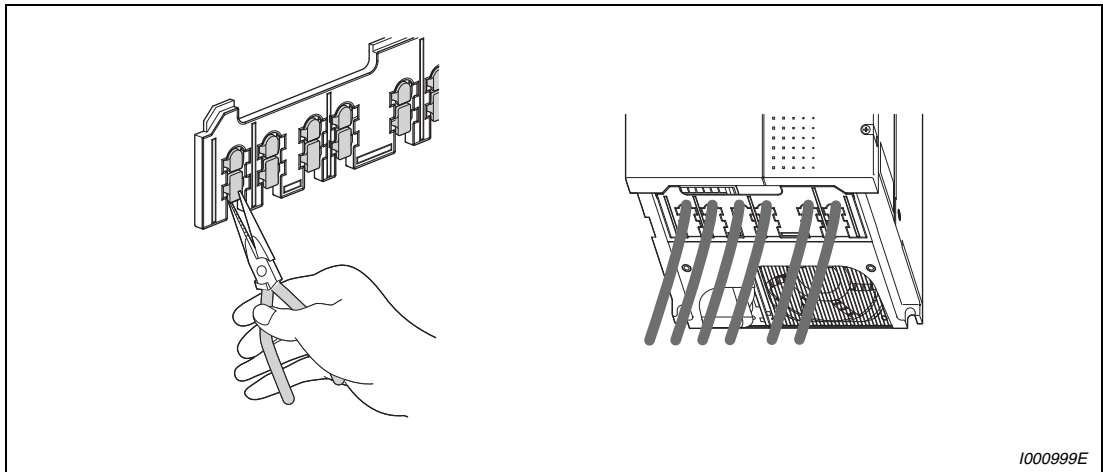

**Fig. 3-4:**  
Connection to the conductors

1001346E

**Wiring cover**

The frequency inverters FR-A740-00470 and 00620 are equipped with a combed shaped wiring cover. For the hook of the wiring cover, cut off the necessary parts using a pair of long-nose pliers etc.



1000999E

**Fig. 3-5:** Combed shaped wiring cover

**NOTE**

Cut off the same numbers of lugs as wires. If you cut off unnecessary parts and no wires are connected, the protective structure (JEM 1030) of the inverter becomes open type (IP00).

### Cables and wiring length

Select the recommended cable size to ensure that a voltage drop will be 2% max.  
If the wiring distance is long between the inverter and motor, a main circuit cable voltage drop will cause the motor torque to decrease especially at the output of a low frequency.  
The following table indicates a selection example for the wiring length of 20m.  
400V class

Applicable Inverter Type	Terminal Screw Size ④	Tightening Torque [Nm]	Crimping Terminal		Cable Size								
					HIV, etc. [mm <sup>2</sup> ] ①				AWG ②		PVC, etc. [mm <sup>2</sup> ] ③		
			R/L1, S/L2, T/L3, P1, P	U, V, W	R/L1, S/L2, T/L3	U, V, W	P, P1	Earth cable gauge	R/L1, S/L2, T/L3, P1, P	U, V, W	R/L1, S/L2, T/L3, P1, P	U, V, W	Earth cable gauge
FR-A740-00023 to 00126-EC	M4	1.5	2-4	2-4	2	2	2	2	14	14	2.5	2.5	2.5
FR-A740-00170-EC	M4	1.5	2-4	2-4	2	2	3.5	3.5	12	14	2.5	2.5	4
FR-A740-00250-EC	M4	1.5	5.5-4	5.5-4	3.5	3.5	3.5	3.5	12	12	4	4	4
FR-A740-00310-EC	M5	2.5	5.5-5	5.5-5	3.5	3.5	3.5	8	10	10	6	6	10
FR-A740-00380-EC	M5	2.5	8-5	8-5	8	8	8	8	8	8	10	10	10
FR-A740-00470-EC	M6	4.4	14-6	8-6	14	8	14	14	6	8	16	10	16
FR-A740-00620-EC	M6	4.4	14-6	14-6	14	14	22	14	6	6	16	16	16
FR-A740-00770-EC	M6	4.4	22-6	22-6	22	22	22	14	4	4	25	25	16
FR-A740-00930-EC	M8	7.8	22-8	22-8	22	22	22	14	4	4	25	25	16
FR-A740-01160-EC	M8	7.8	38-8	38-8	38	38	38	22	1	2	50	50	25
FR-A740-01800-EC	M8	7.8	60-8	60-8	60	60	60	22	1/0	1/0	50	50	25
FR-A740-02160-EC	M10	14.7	60-10	60-10	60	60	60	38	1/0	1/0	50	50	25
FR-A740-02600-EC	M10	14.7	60-10	60-10	60	60	80	38	3/0	3/0	50	50	25
FR-A740-03250-EC	M10/M12	14.7	80-10	80-10	80	80	80	38	3/0	3/0	70	70	35
FR-A740-03610-EC	M10/M12	14.7	100-10	100-10	100	100	100	38	4/0	4/0	95	95	50
FR-A740-04320-EC	M12/M10	24.5	150-12	150-12	125	150	150	38	250	250	120	120	70
FR-A740-04810-EC	M12/M10	24.5	150-12	150-12	150	150	150	38	300	300	150	150	95
FR-A740-05470-EC	M12/M10	24.5	100-12	100-12	2 × 100	2 × 100	2 × 100	60	2 × 4/0	2 × 4/0	2 × 95	2 × 95	95
FR-A740-06100-EC	M12/M10	24.5	100-12	100-12	2 × 100	2 × 100	2 × 125	60	2 × 4/0	2 × 4/0	2 × 95	2 × 95	95
FR-A740-06830-EC	M12/M10	24.5	150-12	150-12	2 × 125	2 × 125	2 × 125	60	2 × 250	2 × 250	2 × 120	2 × 120	120
FR-A740-07700-EC	M12/M10	24.5	150-12	150-12	2 × 150	2 × 150	2 × 150	100	2 × 300	2 × 300	2 × 150	2 × 150	150
FR-A740-08660-EC	M12/M10	24.5	C2-200	C2-200	2 × 200	2 × 200	2 × 200	100	2 × 350	2 × 350	2 × 185	2 × 185	2 × 95
FR-A740-09620-EC	M12/M10	24.5	C2-200	C2-200	2 × 200	2 × 200	2 × 200	100	2 × 400	2 × 400	2 × 185	2 × 185	2 × 95
FR-A740-10940-EC	M12/M10	24.5	C2-250	C2-250	3 × 250	3 × 250	3 × 250	100	3 × 500	3 × 500	2 × 240	2 × 240	2 × 120
FR-A740-12120-EC	M12/M10	24.5	C2-200	C2-250	3 × 200	2 × 250	3 × 200	2 × 200	3 × 500	3 × 500	2 × 240	2 × 240	2 × 120

Tab. 3-4: Cable size

- ① For the 01800 or less, the recommended cable size is that of the HIV cable (600V class 2 vinyl-insulated cable) with continuous maximum permissible temperature of 75°C. Assumes that the ambient temperature is 50°C or less and the wiring distance is 20m or less.  
For the 02160 or more, the recommended cable size is that of LMFC (heat resistant flexible cross-linked polyethylene insulated cable) with continuous maximum permissible temperature of 90°C. Assumes that the ambient temperature is 50°C or less and wiring is performed in an enclosure.
- ② For the 01160 or less, the recommended cable size is that of the THHW cable with continuous maximum permissible temperature of 75°C. Assumes that the ambient temperature is 40°C or less and the wiring distance is 20m or less.  
For the 01800 or more, the recommended cable size is that of THHN cable with continuous maximum permissible temperature of 90°C. Assumes that the ambient temperature is 40°C or less and wiring is performed in an enclosure. (Selection example for use mainly in the United States.)
- ③ For the 01160 or less, the recommended cable size is that of the PVC cable with continuous maximum permissible temperature of 70°C. Assumes that the ambient temperature is 40°C or less and the wiring distance is 20m or less.  
For the 01800 or more, the recommended cable size is that of XLPE cable with continuous maximum permissible temperature of 90°C. Assumes that the ambient temperature is 40°C or less and wiring is performed in an enclosure.
- ④ The terminal screw size indicates the terminal size for R/L1, S/L2, T/L3, U, V, W, and a screw for earthing.  
For the 03250 and 03610, screw sizes are different (<R/L1, S/L2, T/L3, U, V, W, a screw for earthing (grounding)> - <P/+ for option connection>)  
For the 04320 or more, screw sizes are different. (<R/L1, S/L2, T/L3, U, V, W> - <a screw for earthing (grounding)>)

The line voltage drop can be calculated by the following expression:

$$\text{Line drop voltage [V]} \square \frac{\sqrt{3} \times \text{wire resistant [m}\Omega\text{/m]} \times \text{wiring distance [m]} \times \text{current [A]}}{1000}$$

Use a larger diameter cable when the wiring distance is long or when it is desired to decrease the voltage drop (torque reduction) in the low speed range.



**CAUTION:**

- ***Tighten the terminal screw to the specified torque. A screw that has been tighten too loosely can cause a short circuit or malfunction. A screw that has been tighten too tightly can cause a short circuit or malfunction due to the unit breakage.***
- ***Use crimping terminals with insulation sleeve to wire the power supply and motor.***

## Notes on earthing

**WARNING:**

**Leakage currents flow in the inverter or the EMC filter respectively. To prevent an electric shock, the inverter, input filter and motor must be earthed. (This inverter must be earthed. Earthing must conform to the requirements of national and local safety regulations and electrical codes. (JIS, NEC section 250, IEC 536 class 1 and other applicable standards)).**

Use the dedicated earth terminal to earth the inverter. (Do not use the screw in the casing, chassis, etc.)

Use the thickest possible earth cable. Use the cable whose size is equal to or greater than that indicated in Tab. 3-4, and minimize the cable length. The earthing point should be as near as possible to the inverter.

Always earth the motor and inverter

- Purpose of earthing

Generally, an electrical apparatus has an earth terminal, which must be connected to the ground before use.

An electrical circuit is usually insulated by an insulating material and encased. However, it is impossible to manufacture an insulating material that can shut off a leakage current completely, and actually, a slight current flow into the case. The purpose of earthing the case of an electrical apparatus is to prevent operator from getting an electric shock from this leakage current when touching it.

To avoid the influence of external noises, this earthing is important to audio equipment, sensors, computers and other apparatuses that handle low-level signals or operate very fast.

- Earthing methods and earthing work

As described previously, earthing is roughly classified into an electrical shock prevention type and a noise affected malfunction prevention type. Therefore, these two types should be discriminated clearly, and the following work must be done to prevent the leakage current having the inverter's high frequency components from entering the malfunction prevention type earthing:

- Where possible, use independent earthing for the inverter. If independent earthing (I) is impossible, use joint earthing (II) where the inverter is connected with the other equipment at an earthing point. Joint earthing as in (III) must be avoided as the inverter is connected with the other equipment by a common earth cable.

Also a leakage current including many high frequency components flows in the earth cables of the inverter and inverter-driven motor. Therefore, they must use the independent earthing method and be separated from the earthing of equipment sensitive to the aforementioned noises.

In a tall building, it will be a good policy to use the noise malfunction prevention type earthing with steel frames and carry out electric shock prevention type earthing in the independent earthing method.

- This inverter must be earthed. Earthing must conform to the requirements of national and local safety regulations and electrical codes. (JIS, NEC section 250, IEC 536 class 1 and other applicable standards).
- Use the thickest possible earth cable. The earth cable should be of not less than the size indicated in Tab. 3-4.
- The grounding point should be as near as possible to the inverter, and the ground wire length should be as short as possible.
- Run the earth cable as far away as possible from the I/O wiring of equipment sensitive to noises and run them in parallel in the minimum distance..

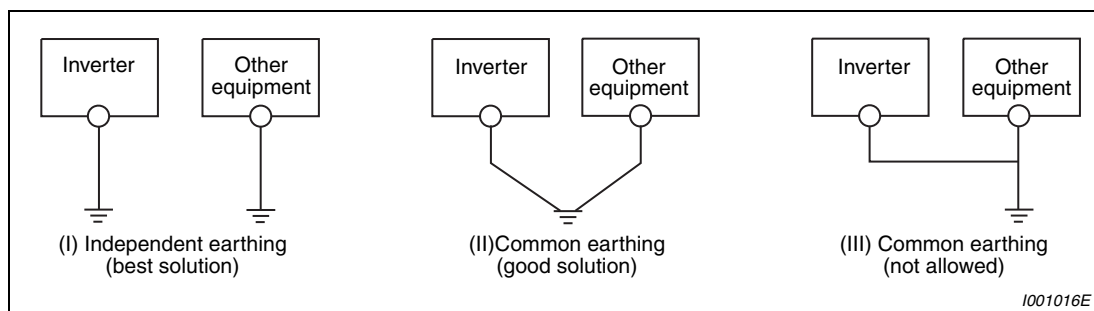

**Fig. 3-6:** Earthing the drive



**Total wiring length**

The maximum possible length of the motor cables depends on the capacity of the inverter and the selected carrier frequency. The cables should never be longer than 100m (unshielded).

The lengths in the following table are for unshielded cables. When shielded cables are use divide the values listed in the table by 2. Note that the values are for the total wiring length – if you connect more than one motor in parallel you must add the lengths of the individual motor cables.

Pr. 72 "PWM frequency selection" setting (carrier frequency)	00023	00038	≥ 00052
≤ 2 (2kHz)	300m	500m	500m
3 (3kHz), 4 (4kHz)	200m	300m	500m
5 (5kHz) to 9 (9kHz)	100m		
≥ 10 (10kHz)	50m		

**Tab. 3-5:** Total wiring length

**NOTE**

For the 02160 or more, the setting range of Pr. 72 PWM frequency selection is "0 to 6".

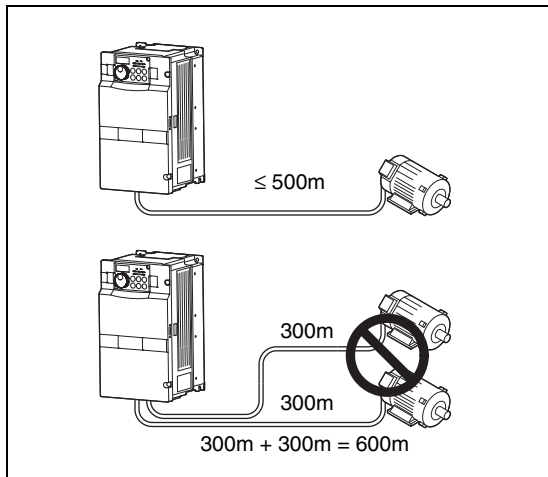

**Fig. 3-7:**  
Total wiring length (00052 or more)

1001017E

**NOTE**

Note that the motor windings are subjected to significantly higher loads when the motor is operated by inverter than with normal mains operation. The motors must be approved for inverter operation by the manufacturer (refer also to section 3.9.5).

### 3.3.3 Separate power supply for the control circuit

In an alarm condition the frequency inverter's integrated alarm relay only remains active as long as there is a mains power supply on terminals R/L1, S/L2 and T/L3. If you want the alarm signal to remain active after the frequency inverter has been switched off a separate power supply for the control circuit is required, which should be connected as shown in the circuit diagram below. Remove the shortening jumpers from the terminal block and connect the 380–480V AC, 50/60Hz mains power supply to terminals R1/L11 and S1/L21. The control circuit power consumption on L11/L21 is 60VA for 00380 or less and 80VA for 00470 to 12120.

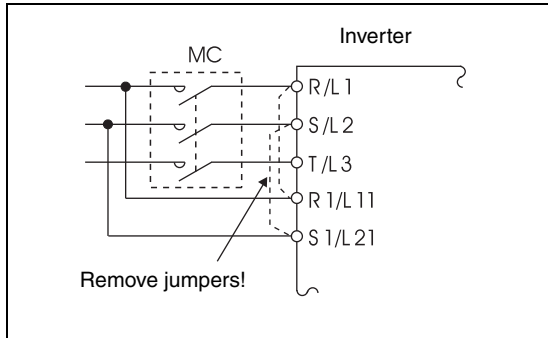
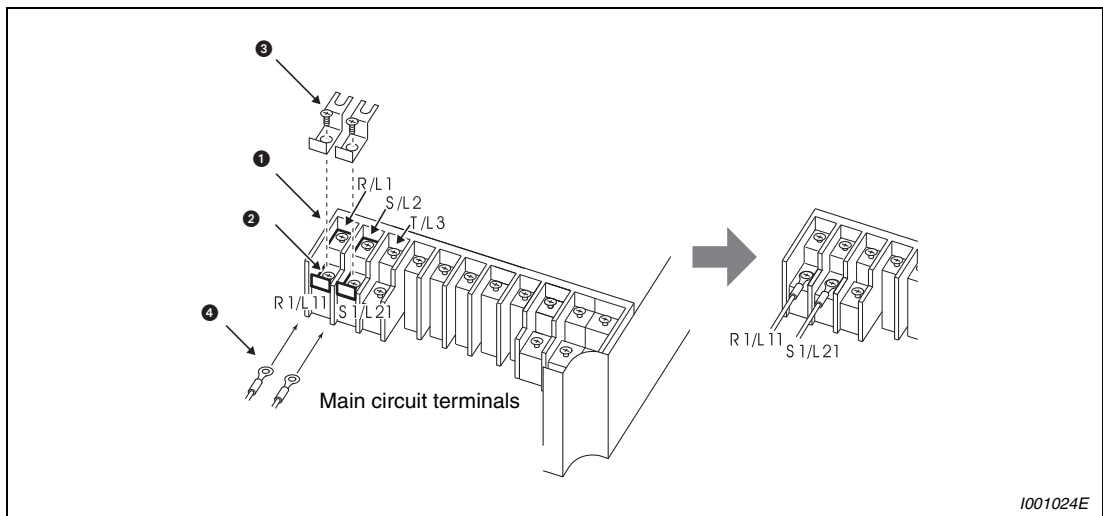

**Fig. 3-8:**  
Power supply for control and main circuit

I001023E

#### FR-A740-00023 to 00126-EC

- ① Loosen the upper screws ❶ and then the lower screws ❷.
- ② Remove the jumpers ❸.
- ③ Connect the separate power supply cable for the control circuit to the lower terminals ❹ R1/L11 and S1/L21.

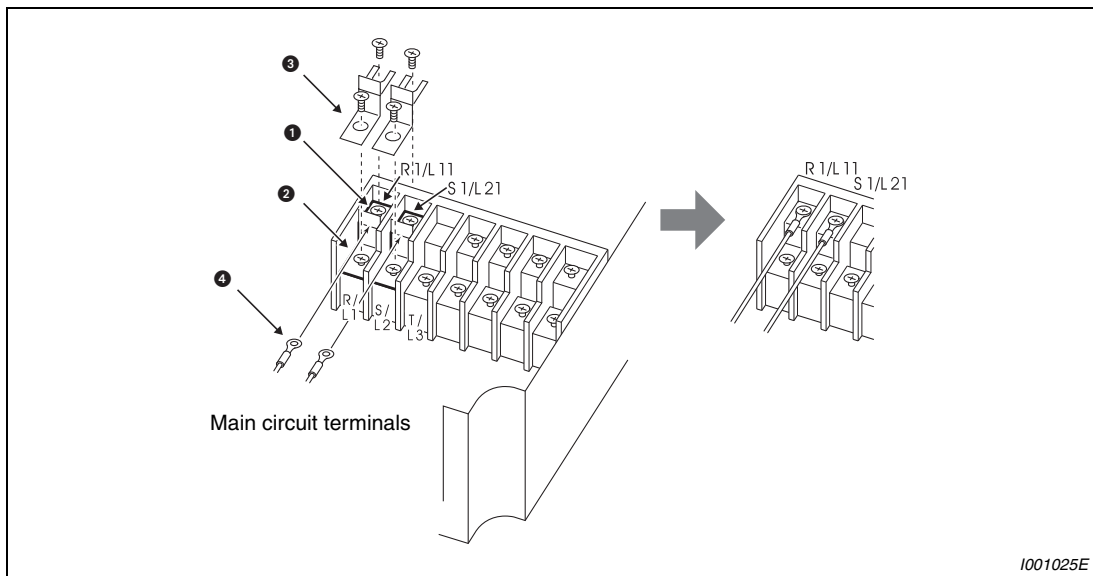

**Fig. 3-9:** Detailed view of the terminals

I001024E

**FR-A740-00170 to 00250-EC**

- ① Loosen the upper screws ① and then the lower screws ②.
- ② Remove the jumpers ③.
- ③ Connect the separate power supply cable for the control circuit to the upper terminals ④ R1/L11 and S1/L21.



**Fig. 3-10:** Detailed view of the terminals

**FR-A740-00310 to 12120-EC**

- ① Loosen the upper screws ① and then the lower screws ②.
- ② Remove the jumpers ③.
- ③ Connect the separate power supply cable for the control circuit to the upper terminals ④ R1/L11 and S1/L21.

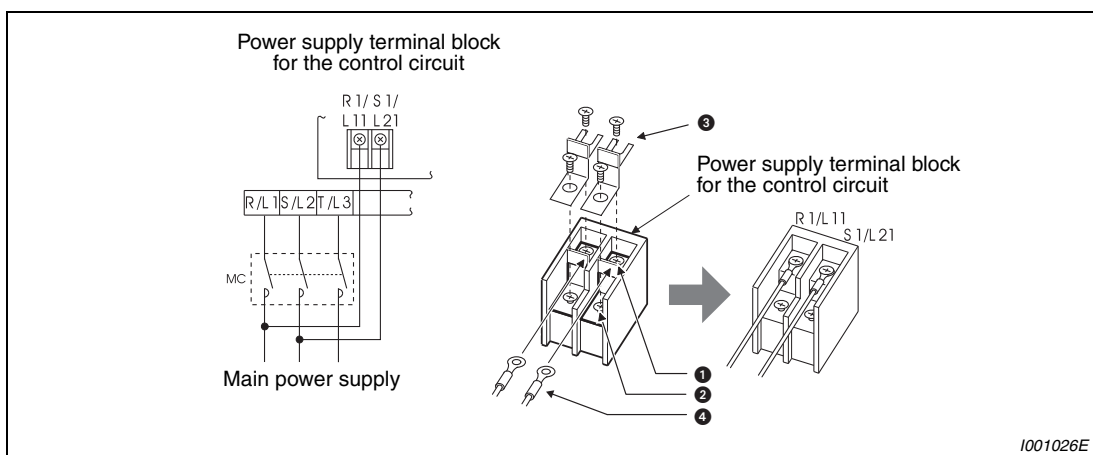
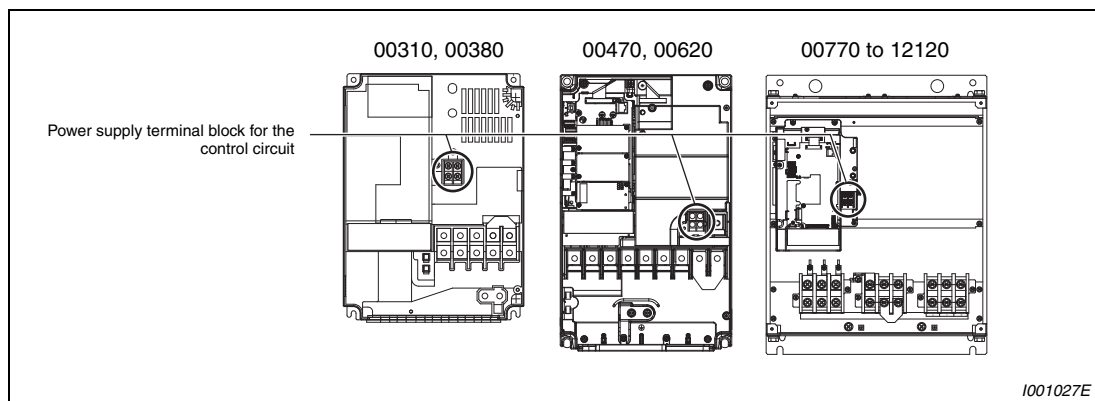

**Fig. 3-11:** Detailed view of the terminals



**CAUTION:**  
 Never connect the power cable to the terminals in the lower stand. Doing so will damage the inverter.

## Position of the power supply terminal block for the control circuit



**Fig. 3-12:** Position of the power supply terminal block for the control circuit

**CAUTION:**

- **Do not turn off the control power (terminals R1/L11 and S1/L21) with the main circuit power (R/L1, S/L2, T/L3) on. Doing so may damage the inverter.**
- **Be sure to use the inverter with the jumpers across terminals R/L1-R1/L11 and S/L2-S1/L21 removed when supplying power from other sources. The inverter may be damaged if you do not remove the jumper.**
- **The voltage should be the same as that of the main control circuit when the control circuit power is supplied from other than the primary side of the MC.**
- **The power capacity is 60VA or more for 00380 or 80VA or more for 00470 to 12120 when separate power is supplied from R1/L11, S1/L21.**
- **When the power supply used with the control circuit is different from the one used with the main circuit, make up a circuit which will switch off the main circuit power supply terminals R/L1, S/L2, T/L3 when the control circuit power supply terminals R1/L11, S1/L21 are switched off.**
- **If the main circuit power is switched off (for 0.1s or more) then on again, the inverter resets and an alarm output will not be held.**

## 3.4 Control circuit specifications

The functions of the terminals highlighted in grey can be adjusted with parameters 178–196 “Input terminal function assignment” (refer to section 6.14). The listed settings show the default configuration as shipped, which you can restore by resetting to the factory defaults.

### Input signals

	Terminal	Name	Description		Rated Specifications	Refer to
Contact input	STF	Forward rotation start	Turn on the STF signal to start forward rotation and turn it off to stop.	When the STF and STR signals are turned on simultaneously, the stop command is given.	Input resistance: 4.7kΩ Voltage at opening: 21 to 27V DC Contacts at short-circuited: 4 to 6mA DC	6-286
	STR	Reverse rotation start	Turn on the STR signal to start reverse rotation and turn it off to stop.			6-286
	STOP	Start self holding selection	Turn on the STOP signal to self-hold the start signal.	6-286		
	RH, RM, RL	Multi-speed selection	Multi-speed can be selected according to the combination of RH, RM and RL signals.	6-286		
	JOG	Jog mode selection	Turn on the JOG signal to select Jog operation (initial setting) and turn on the start signal to start Jog operation.	6-286		
		Pulse train input	JOG terminal can be used as pulse train input terminal. To use as pulse train input terminal, the Pr. 291 setting needs to be changed. (maximum input pulse: 100kpulses/s)	Input resistance 2kΩ Contacts at short-circuited: 8 to 13mADC 6-286		
	RT	Second function	Turn on the RT signal to select second function. When the second function such as "second torque boost" and "second V/F (base frequency)" are set, turning on the RT signal selects these functions.	6-286		
	MRS	Output stop	Turn on the MRS signal (20ms or more) to stop the inverter output. Use to shut off the inverter output when stopping the motor by electromagnetic brake.	6-286		
	RES	Reset	Used to reset alarm output provided when protective function is activated. Turn on the RES signal for more than 0.1s, then turn it off. Initial setting is for reset always. By setting Pr. 75, reset can be set to enabled only at an inverter alarm occurrence. Recover about 1s after reset is cancelled.	Input resistance: 4.7kΩ Voltage at opening: 21 to 27V DC Contacts at short-circuited: 4 to 6mA DC 6-286		
	AU	Terminal 4 input selection	Terminal 4 is made valid only when the AU signal is turned on. (The frequency setting signal can be set between 4 and 20mA DC.) Turning the AU signal on makes terminal 2 (voltage input) invalid.	6-369		
PTC input		AU terminal is used as PTC input terminal (thermal protection of the motor). When using it as PTC input terminal, set the AU/PTC switch to PTC and assign the PTC function to the AU input terminal.	6-217			
CS	Selection of automatic restart after instantaneous power failure	When the CS signal is left on, the inverter restarts automatically at power restoration. Note that restart setting is necessary for this operation. In the initial setting, a restart is disabled. (Refer to Pr. 57 in section 6.16.)	6-286			

Tab. 3-6: Input signals (1)

	Terminal	Name	Description	Rated Specifications	Refer to
Contact input	SD	External transistor common, contact input common (sink)	A determined control function is activated, if the corresponding terminal is connected to the terminal SD (sink logic). The SD terminal is isolated from the digital circuits via opto couplers. The terminal is isolated from the reference potential of the analog circuit (terminal 5). Common reference potential (0V) for 24V DC/0.1A output (PC terminal).	—	—
	PC	24V DC power supply, contact input common (source)	24V DC/0.1A output With negative logic and control via open collector transistors (e.g. a PLC) the positive pole of an external power source must be connected to the PC terminal. With positive logic the PC terminal is used as a common reference for the control inputs. This means that when positive logic is selected (default setting of the EC units) the corresponding control function is activated by connecting its terminal to the PC terminal.	Power supply voltage range: 19.2 to 28.8V DC Current consumption: 100mA	3-25
Frequency setting	10E (Output voltage 10V DC)	Frequency setting power supply	When connecting the frequency setting potentiometer at an initial status, connect it to terminal 10. Change the input specifications with Pr. 73 when connecting it to terminal 10E. (Refer to section 6.20.3.) Recommended potentiometer: 1 k $\Omega$ , 2 W linear, multi turn potentiometer	10V DC $\pm$ 0.4V, Permissible load current 10mA	6-369
	10 (Output voltage 5V DC)			5.2V DC $\pm$ 0.2V, Permissible load current 10mA	6-369
	2	Frequency setting (voltage)	Inputting 0 to 5VDC (or 0 to 10V, 0/4 to 20mA) provides the maximum output frequency at 5V (10V, 20mA) and makes input and output proportional. Use Pr. 73 to switch from among input 0 to 5VDC (initial setting), 0 to 10VDC, and 0 to 20mA. Set the voltage/current input switch in the ON position to select current input (0 to 20mA). <sup>①</sup>	Voltage input: Input resistance: 10k $\Omega$ $\pm$ 1k $\Omega$ Maximum permissible voltage: 20V DC	6-369
	4	Frequency setting (current)	Inputting 0/4 to 20mA DC (or 0 to 5V, 0 to 10V) provides the maximum output frequency at 20mA (5V, 10V) makes input and output proportional. This input signal is valid only when the AU signal is on (terminal 2 input is invalid). Use Pr. 267 to switch between the input 0 to 20mA (initial value) and 0 to 5V DC, 0 to 10V DC. Set the voltage/current input switch in the OFF position to select voltage input (0 to 5V/0 to 10V). Use Pr. 858 to switch terminal functions. <sup>①</sup>	Current input: Input resistance: 245 $\Omega$ $\pm$ 5 $\Omega$ (while power is on) Maximum permissible current: 30mA	6-369

**Tab. 3-6:** Input signals (2)

	Terminal	Name	Description	Rated Specifications	Refer to
Frequency setting	1	Frequency setting auxiliary 0-±5 (10)V DC	Inputting 0 to ±5V DC or 0 to ±10V DC adds this signal to terminal 2 or 4 frequency setting signal. Use Pr. 73 to switch between the input 0 to ±5V DC and 0 to ±10V DC (initial setting).	Input resistance: 10kΩ ± 1kΩ Maximum permissible voltage: ±20V DC	6-369
	5	Frequency setting common and analog outputs	Terminal 5 provides the common reference potential (0V) for all analog set point values and for the analog output signals CA (current) and AM (voltage). The terminal is isolated from the digital circuit's reference potential (SD). This terminal should not be grounded. If local regulations require grounding of the reference potential note that this can propagate any noise in the ground potential to the control electronics, thus increasing sensitivity to interference.	—	6-369

**Tab. 3-6:** Input signals (3)

- ① Set Pr. 73, Pr. 267, and a voltage/current input switch correctly, then input an analog signal in accordance with the setting. Application of voltage with switch on (current input specification) or current with switch off (voltage input specification) could lead to damage to the inverter or analog circuit of external devices. (For details, refer to section 6.20.2.)

## Output signals

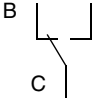
	Terminal	Name	Description	Rated Specifications	Refer to	
Relay	A1, B1, C1	Relay output 1 (alarm output)	<p>The alarm is output via relay contacts. The block diagram shows the normal operation and voltage free status. If the protective function is activated, the relay picks up.</p> 	Contact capacity: 230V/0.3A AC (Power factor: 0.4) or 30V/0.3A DC.	6-298	
	A2, B2, C2	Relay output 2			6-298	
Open collector	RUN	Inverter running	Switched low when the inverter output frequency is equal to or higher than the starting frequency (initial value 0.5Hz). Switched high during stop or DC injection brake operation.	Permissible load: 24V DC, 0,1A (A voltage drop is 2.8V maximum when the signal is on.)	6-298	
	SU	Up to frequency	The SU output supports a monitoring of frequency setting value and frequency current value. The output is switched low, once the frequency current value (output frequency of the inverter) approaches the frequency setting value (determined by the setting value signal) within a preset range of tolerance (Pr. 41). Switched high during acceleration/deceleration and at a stop.		6-298	
	OL	Overload alarm	The OL is switched low, if the output current of the inverter exceeds the current limit preset in Pr. 22 and the stall prevention is activated. If the output current of the inverter falls below the current limit preset in Pr. 22, the signal at the OL output is switched high.		Alarm code (4 bit) (Refer to section 6.17.2)	6-298
	IPF	Instantaneous power failure	The output is switched low for a temporary power failure within a range of $15\text{ms} \leq t_{\text{IPF}} \leq 100\text{ms}$ or for under voltage.			6-298
	FU	Frequency detection	The output is switched low once the output frequency exceeds a value preset in Pr. 42 (or 43). Otherwise the FU output is switched high.			6-298
	SE	Open collector output common	Reference potential for the signals RUN, SU, OL, IPF, and FU. This terminal is isolated from the reference potential of the control circuit SD.			—

Tab. 3-7: Output signals (1)



	Terminal	Name	Description	Rated Specifications	Refer to	
Analog output	CA	Analog current output	Select one e.g. output frequency from monitor items. The output signal is proportional to the magnitude of the corresponding monitoring item. Not output during inverter reset.	Output item: Output frequency (initial setting)	Load impedance: 200Ω–450Ω Output signal: 0–20mA	6-330
	AM	Analog voltage output			Output signal: 0–10V DC Permissible load current: 1 mA (load impedance: ≥ 10kΩ) Resolution: 8 bit	6-330

**Tab. 3-7:** Output signals (2)

### Communication

	Terminal	Name	Description	Refer to	
RS-485	—	PU connector	With the PU connector, communication can be made through RS-485. (for connection on a 1:1 basis only) Conforming standard: EIA-485 (RS-485) Transmission format: Multidrop Communication speed: 4800 to 38400bps Overall length: 500m	6-437	
	RS-485 terminal	TXD+	Inverter transmission terminal	With the RS-485 terminal, communication can be made through RS-485. Conforming standard: EIA-485 (RS-485) Transmission format: Multidrop link Communication speed: 300 to 38400bps Overall length: 500m	6-440
		TXD–			
		RXD+	Inverter reception terminal		
		RXD–			
SG	Earth				
USB	—	USB connector	The FR-Configurator can be performed by connecting the inverter to the personnel computer through USB. Interface: Conforms to USB1.1 Transmission speed: 12Mbps Connector: USB B connector (B receptacle)	6-487	

**Tab. 3-8:** Communication signals

### 3.4.1 Changing the control logic

The input signals are set to source logic (SOURCE) when shipped from the factory. To change the control logic, the jumper connector on the control circuit terminal block must be moved to the other position.

(The output signals may be used in either the sink or source logic independently of the jumper connector position.)

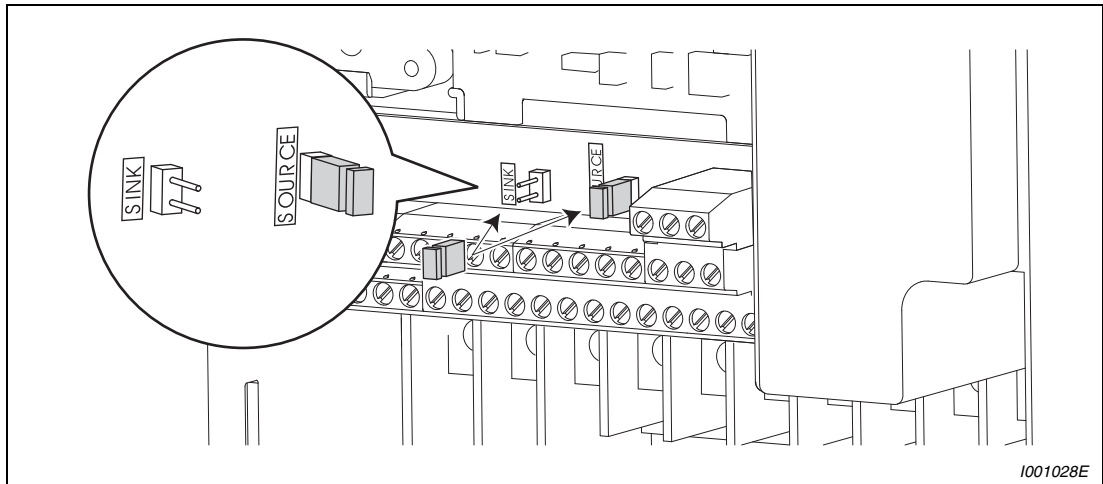

**Fig. 3-13:** Changing the control logic

**NOTE**

Turn off the inverter power before switching a jumper connector.

Sink logic and source logic

- In sink logic, a signal switches on when a current flows from the corresponding signal input terminal. Terminal SD is common to the contact input signals. Terminal SE is common to the open collector output signals.
- In source logic, a signal switches on when a current flows into the corresponding signal input terminal. Terminal PC is common to the contact input signals. Terminal SE is common to the open collector output signals.

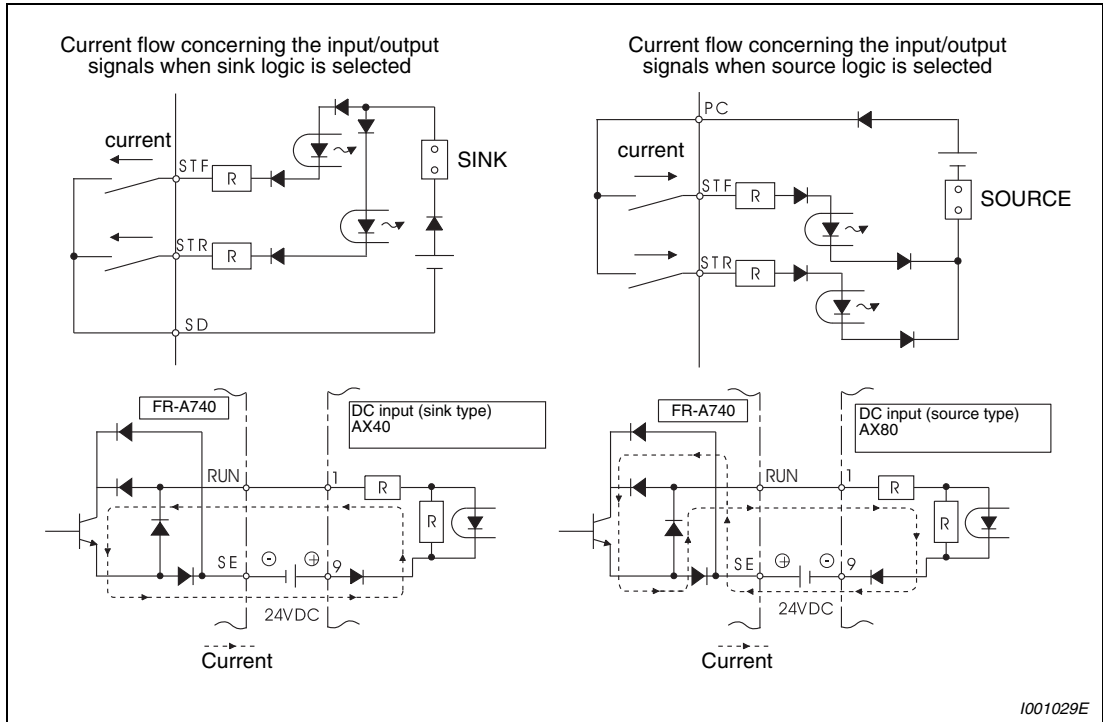
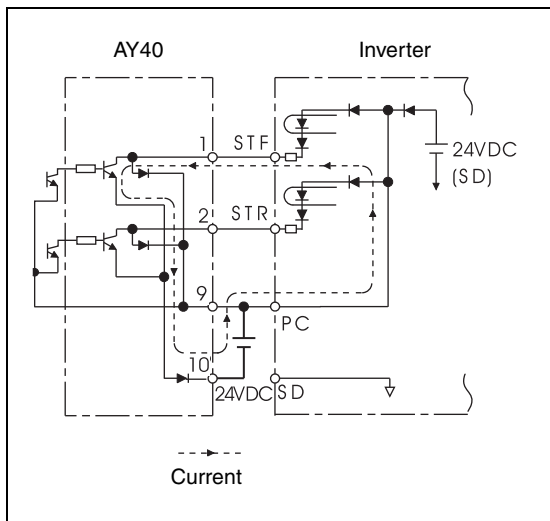

Fig. 3-14: Changing the control logic

**Using an external power supply**

● Sink logic type

Use terminal PC as a common terminal to prevent a malfunction caused by undesirable current. (Do not connect terminal SD of the inverter with terminal 0V of the external power supply. When using terminals PC-SD as a 24V DC power supply, do not install a power supply in parallel in the outside of the inverter. Doing so may cause a malfunction due to undesirable current.)

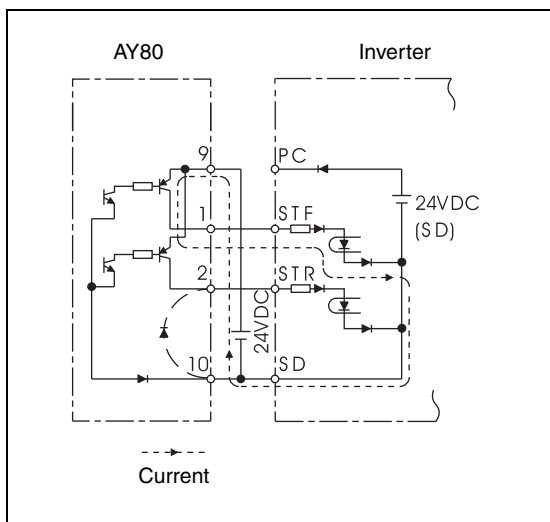

**Fig. 3-15:**  
Using an external power supply in connection with the outputs of a PLC

I001030E

● Source logic type

When using an external power supply for transistor output, use terminal SD as a common to prevent misoperation caused by undesirable current.



**Fig. 3-16:**  
Using an external power supply in connection with the outputs of a PLC

I001031E

### 3.4.2 Control circuit terminals

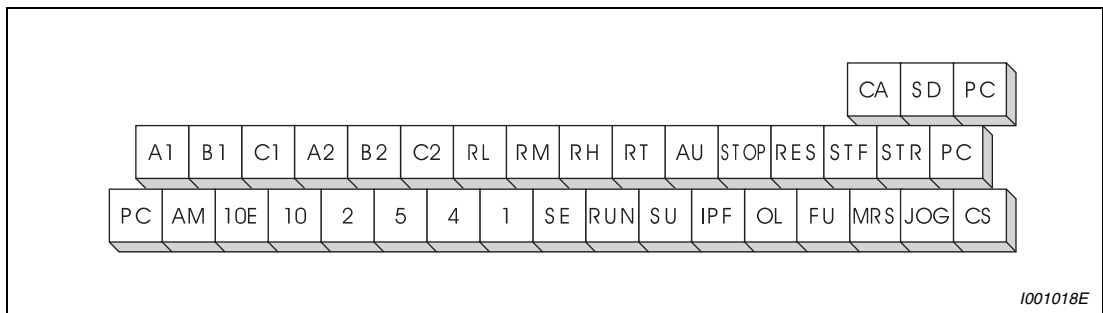

**Fig. 3-17:** Übersicht der Klemmenbelegung

### 3.4.3 Wiring method

- ① Remove about 6mm of the cable insulation. Wire the stripped cable after twisting it to prevent it from becoming loose. In addition, do not solder it.

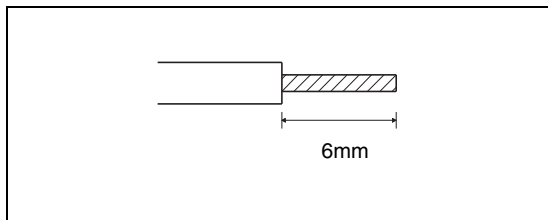

**Fig. 3-18:** Preparation of the cable

- ② Loosen the terminal screw and insert the cable into the terminal.

Item	Description
Screw size	M3
Tightening torque	0,5Nm–0,6Nm
Cable size	0,3mm <sup>2</sup> –0,75mm <sup>2</sup>
Screwdriver	Flat blade screw driver Edge thickness: 0,4mm × 2,5mm

**Tab. 3-9:** Connection to the terminals



**CAUTION:**  
*Under tightening can cause cable disconnection or malfunction. Over tightening can cause a short circuit or malfunction due to damage to the screw or unit.*

### Common terminals of the control circuits PC, 5, SE

Terminals PC, 5, and SE are all common terminals (0V) for I/O signals and are isolated from each other. Avoid connecting the terminal PC and 5 and the terminal SE and 5.

Terminal PC is a common terminal for the contact input terminals (STF, STR, STOP, RH, RM, RL, JOG, RT, MRS, RES, AU, CS).

The open collector circuit is isolated from the internal control circuit by photocoupler.

Terminal 5 is a common terminal for frequency setting signal (terminal 2, 1 or 4), analog current output terminal (CA) and analog output terminal AM. It should be protected from external noise using a shielded or twisted cable.

Terminal SE is a common terminal for the open collector output terminal (RUN, SU, OL, IPF, FU).

The contact input circuit is isolated from the internal control circuit by photocoupler.

### Signal inputs by contactless switches

The contacted input terminals of the inverter (STF, STR, STOP, RH, RM, RL, JOG, RT, MRS, RES, AU, CS) can be controlled using a transistor instead of a contacted switch as shown below.

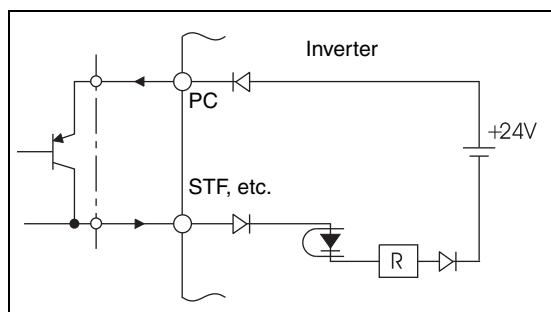
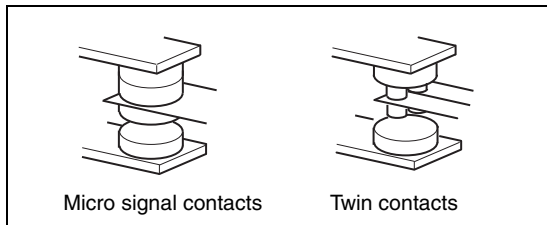

**Fig. 3-19:**  
External signal input using transistor

1001220E

### 3.4.4 Wiring instructions

- Terminals 5, PC and SE are common to the I/O signals and isolated from each other. Do not earth (ground). Avoid connecting the terminal PC and 5 and the terminal SE and 5.
- Use shielded or twisted cables for connection to the control circuit terminals and run them away from the main and power circuits (including the 200V relay sequence circuit).
- Use two or more parallel micro-signal contacts or twin contacts to prevent a contact faults when using contact inputs since the control circuit input signals are micro-currents.



**Fig. 3-20:**  
Contacts

I001021E

- Do not apply a voltage to the contact input terminals (e.g. STF) of the control circuit.
- Always apply a voltage to the alarm output terminals (A, B, C) via a relay coil, lamp, etc.
- It is recommended to use the cables of 0.75mm<sup>2</sup> gauge for connection to the control circuit terminals.
- If the cable gauge used is 1.25mm<sup>2</sup> or more, the front cover may be lifted when there are many cables running or the cables are run improperly, resulting in an operation panel contact fault.
- The wiring length should be 30m maximum.

#### Wiring of the control circuit of the 02160 or more

For wiring of the control circuit of the 02160 or more, separate away from wiring of the main circuit. Make cuts in rubber bush of the inverter side and lead wires.

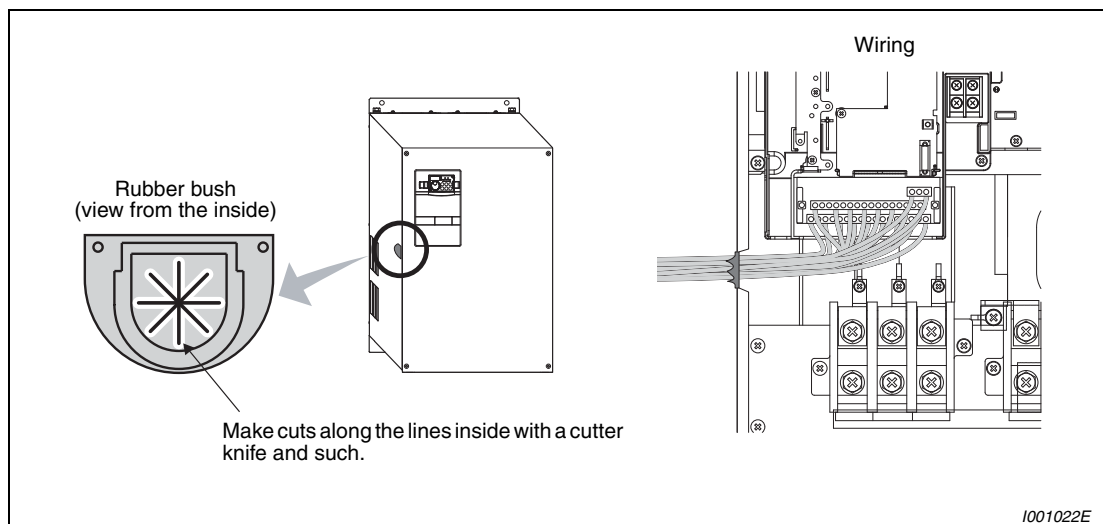

I001022E

**Fig. 3-21:** Wiring of the control circuit of the 02160 or more

### 3.5 Connecting the operation panel using a connection cable

When connecting the operation panel (FR-DU07) to the inverter using a cable, the operation panel can be mounted on the enclosure surface and operationally improves.

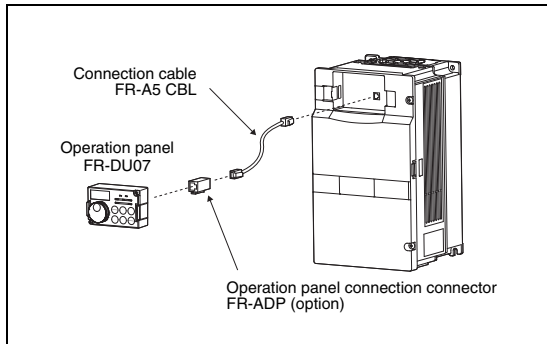

**Fig. 3-22:**  
*Connecting the operation panel using a connection cable*

1001032E

#### NOTES

Overall wiring length when the operation panel is connected: 20m.

Using the PU connector, the frequency inverter can be connected to a RS-485 interface of a personal computer, etc. (refer to section 6.23).



### 3.6 RS-485 terminal block

Specification	Description
Conforming standard	EIA-485 (RS-485)
Transmission format	Multidrop link
Communication speed	Max. 38400bps
Overall length	500m
Connection cable	Twisted pair cable (4 pairs)

**Tab. 3-10:** Specifications of the RS-485 terminal block

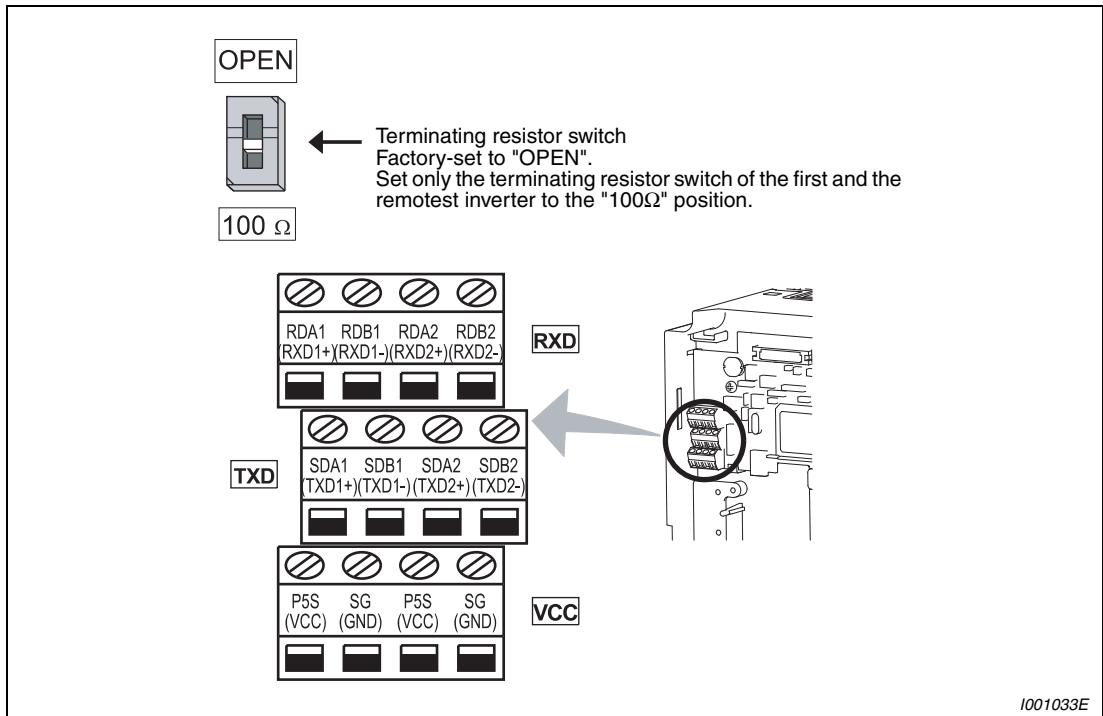
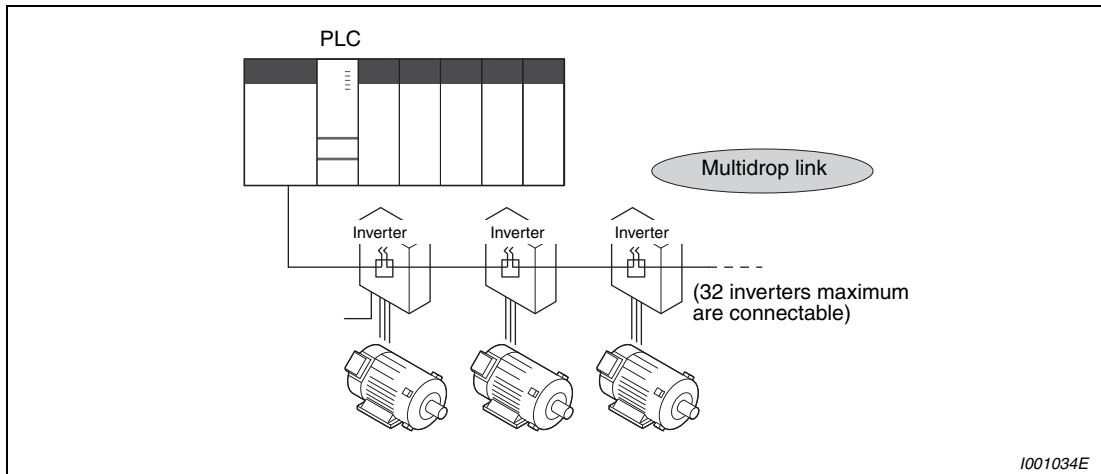

**Fig. 3-23:** RS-485 terminal block

### 3.6.1 Communication operation

Using the PU connector or RS-485 terminal, you can perform communication operation from a personal computer etc. When the PU connector is connected with a personal, FA or other computer by a communication cable, a user program can run and monitor the inverter or read and write to parameters.

For the Mitsubishi inverter protocol (computer link operation), communication can be performed with the PU connector and RS-485 terminal. For the Mod bus RTU protocol, communication can be performed with the RS-485 terminal. (Refer to section 6.23.)



**Fig. 3-24:** RS-485 terminal block of the frequency inverter

### 3.6.2 USB communication specification

The inverter can be connected to a computer via USB cable (version 1.1). You can perform parameter setting and monitoring with the FR Configurator.

Specification	Description
Interface	USB 1.1
Transmission speed	12Mbps
Maximum cable length	5m
Connector	USB B connector (B receptacle)
Power supply	Self-power supply

**Tab. 3-11:** USB connector specification

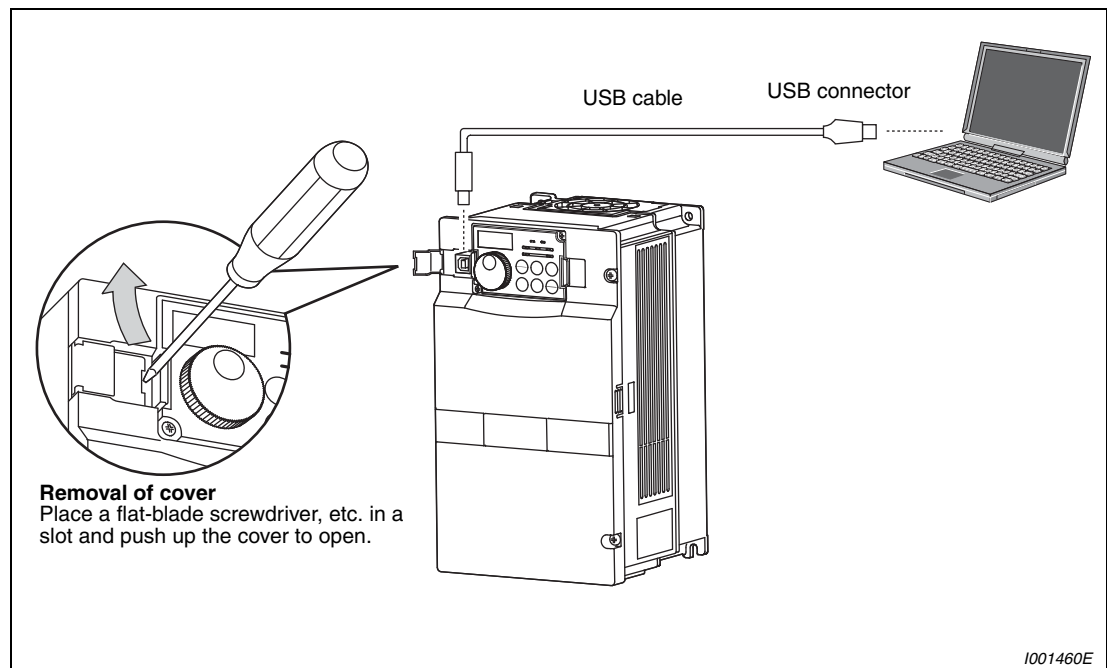

**Fig. 3-25:** Connection to the USB interface

### 3.7 Connection of motor with encoder (vector control)

Following functions can be performed by full-scale vector control operation using a motor with encoder and a plug-in option FR-A7AP.

- Orientation control
- Encoder feedback control
- Speed control
- Torque control

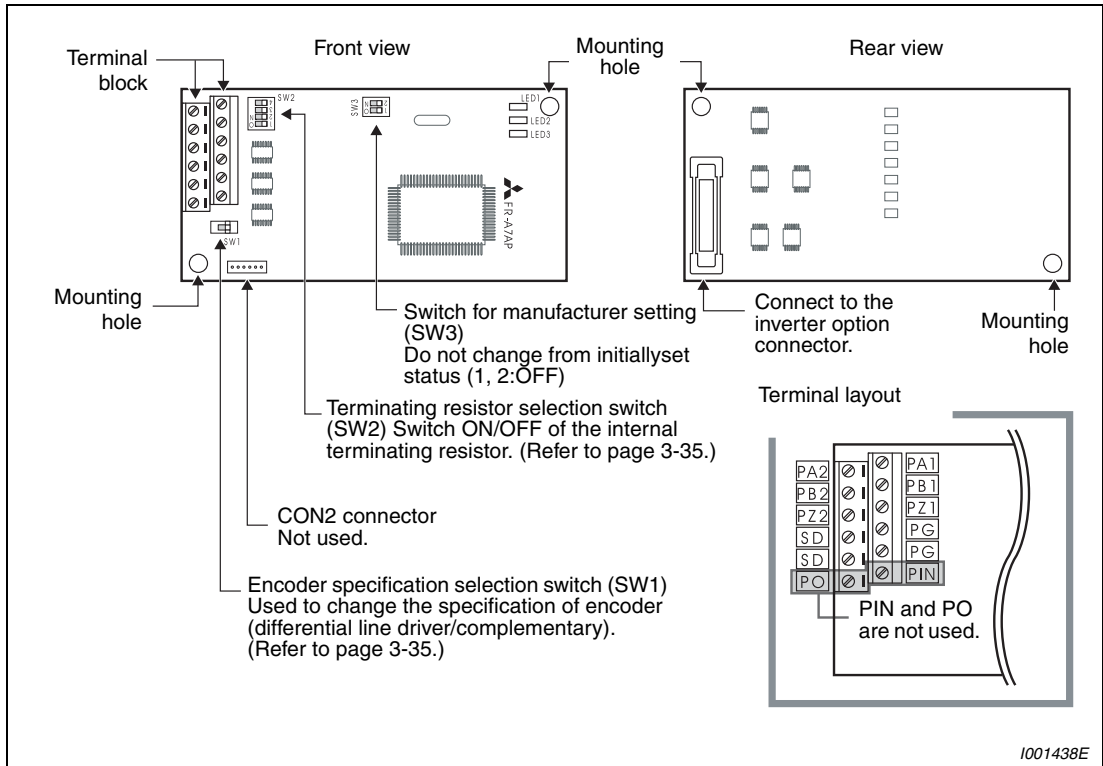

Fig. 3-26: Description of the option FR-A7AP

Terminal	Terminal Name	Description
PA1	Encoder A-phase signal input terminal	A-, B- and Z-phase signals are input from the encoder.
PA2	Encoder A-phase inverse signal input terminal	
PB1	Encoder B-phase signal input terminal	
PB2	Encoder B-phase inverse signal input terminal	
PZ1	Encoder Z-phase signal input terminal	
PZ2	Encoder Z-phase inversion signal input terminal	
PG	Encoder power supply (positive side) input terminal	Input terminal for the encoder power supply. Connect the external power supply (5V, 12V, 15V, 24V) and the encoder power cable.
SD	Encoder power supply ground terminal	
PIN	Not used.	
PO		

Tab. 3-12: Terminals of the FR-A7AP

**Switches of the FR-A7AP**

- Encoder specification selection switch (SW1)  
Select either differential line driver or complementary. It is initially set to the differential line driver. Switch its position according to output circuit.

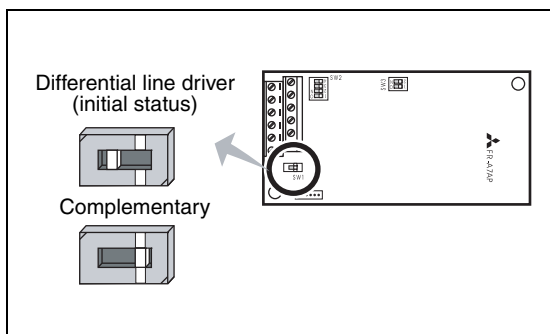

**Fig. 3-27:**  
Encoder specification selection switch

1001439E

- Terminating resistor selection switch (SW2)  
Select ON/OFF of the internal terminating resistor. Set the switch to ON (initial status) when an encoder output type is differential line driver and set to OFF when complimentary.  
ON : with internal terminating resistor (initial status)  
OFF: without internal terminating resistor

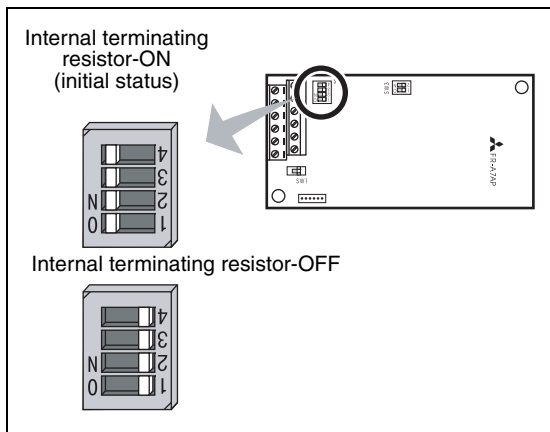

**Fig. 3-28:**  
Terminating resistor selection switch

1001440E

**NOTES**

- Set all switches to the same setting (ON/OFF).
- If the encoder output type is differential line driver, set the terminating resistor switch to the "OFF" position when sharing the same encoder with other unit (NC (numerical controller), etc) or a terminating resistor is connected to other unit.

Motor		Encoder Specification Selection Switch (SW1)	Terminating Resistor Selection Switch (SW2)	Power Specifications ②
Mitsubishi standard motor Mitsubishi high efficiency motor	SF-JR	Differential	ON	5V
	SF-HR	Differential	ON	5V
	Others	①	①	①
Mitsubishi constant-torque motor	SF-JRCA	Differential	ON	5V
	SF-HRCA	Differential	ON	5V
	Others	①	①	①
Vector control dedicated motor	SF-V5RU	Differential	OFF	12V
Other manufacturer motor	—	①	①	①

**Tab. 3-13:** Motor used and switch setting

- ① Set according to the motor (encoder) used.
- ② Choose a power supply (5V/12V/15V/24V) for encoder according to the encoder used.



**CAUTION:**  
**SW3 switch is for manufacturer setting. Do not change the setting.**

Item	Description
Resolution	1024 Pulse/Rev
Power supply voltage	5V DC ± 10%
Current consumption	150mA
Output signal form	A, B phases (90° phase shift) Z phase: 1 pulse/rev
Output circuit	Differential line driver 74LS113 equivalent
Output voltage	H level: 2.4V or more L level: 0.5V or less

**Tab. 3-14:** Encoder specification

**NOTE**

| Encoder with resolution of 1000 to 4096 pulse/rev is recommended.

**Encoder Cable**

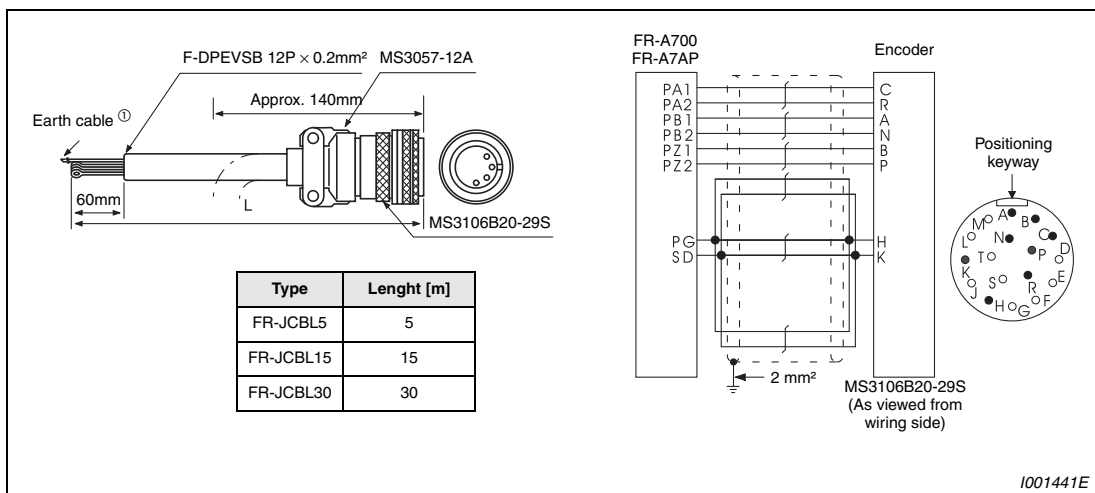
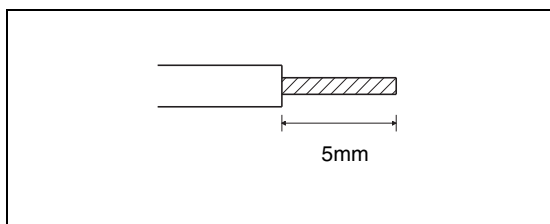

**Fig. 3-29: SF-JR Motor with Encoder**

① As the terminal block of the FR-A7AP is an insertion type, earth cables need to be modified. (See below)

When using the dedicated encoder cable (FR-JCBL, FR-V5CBL, etc.) for the conventional motor, cut the crimping terminal of the encoder cable and strip its sheath to make its cables loose. Also, protect the shielded cable of the twisted pair shielded cable to ensure that it will not make contact with the conductive area.

Wire the stripped cable after twisting it to prevent it from becoming loose. In addition, do not solder it. Use a bar terminal as necessary.



**Fig. 3-30: Cable stripping size**

I001326E

**Connection to the option FR-A7AP**

Motor	SF-JR/HR/JRCA/HRCA (with Encoder)	
Encoder Cable	FR-JCBL	
FR-A7AP-terminal	PA1	PA
	PA2	PAR
	PB1	PB
	PB2	PBR
	PZ1	PZ
	PZ2	PZR
	PG	5E
SD	AG2	

**Tab. 3-15: Connection terminal compatibility table**

**Wiring**

● Speed control

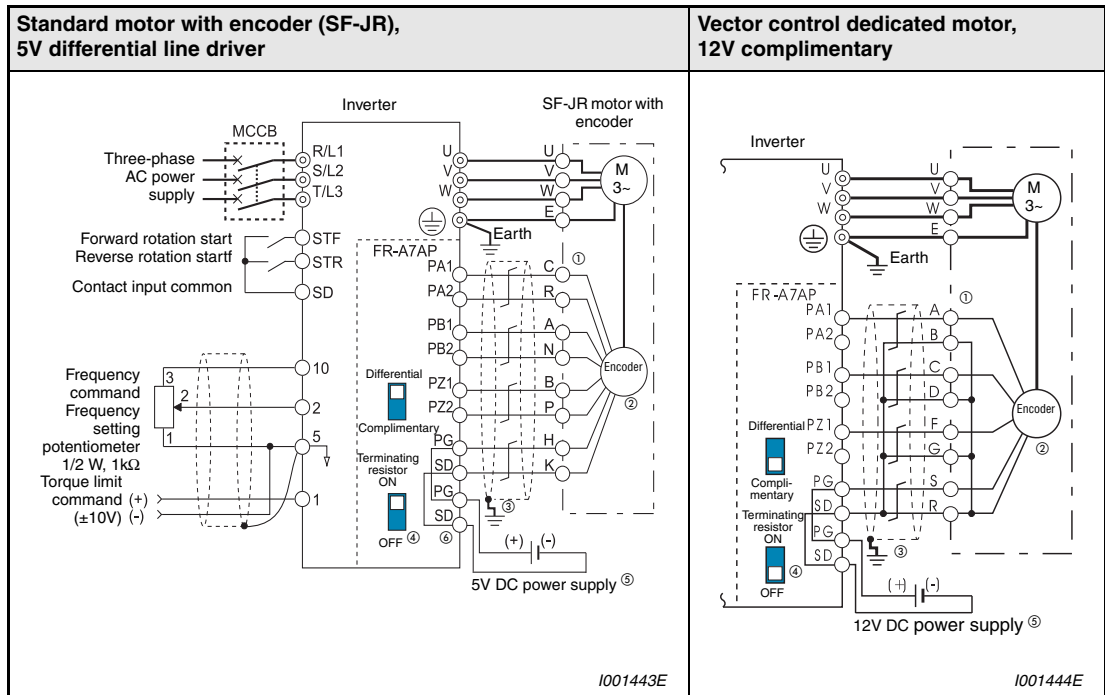

**Tab. 3-16: Speed control**

- ① The pin number differs according to the encoder used. Speed control and torque control are properly performed even without connecting Z phase.
- ② Connect the encoder so that there is no looseness between the motor and motor shaft. Speed ratio should be 1:1.
- ③ Earth (Ground) the shielded cable of the encoder cable to the enclosure with a P clip, etc. (Refer to page 3-41.)
- ④ For the complimentary, set the terminating resistor selection switch to off position. (Refer to page 3-35.)
- ⑤ A separate power supply of 5V/12V/15V/24V is necessary according to the encoder power specification. When performing orientation control together, an encoder and power supply can be shared.
- ⑥ For terminal compatibility of the FR-JCBL and FR-A7AP, refer to page 3-37.

**NOTE**

The figure above shows the connection when using sink logic.



● Torque control

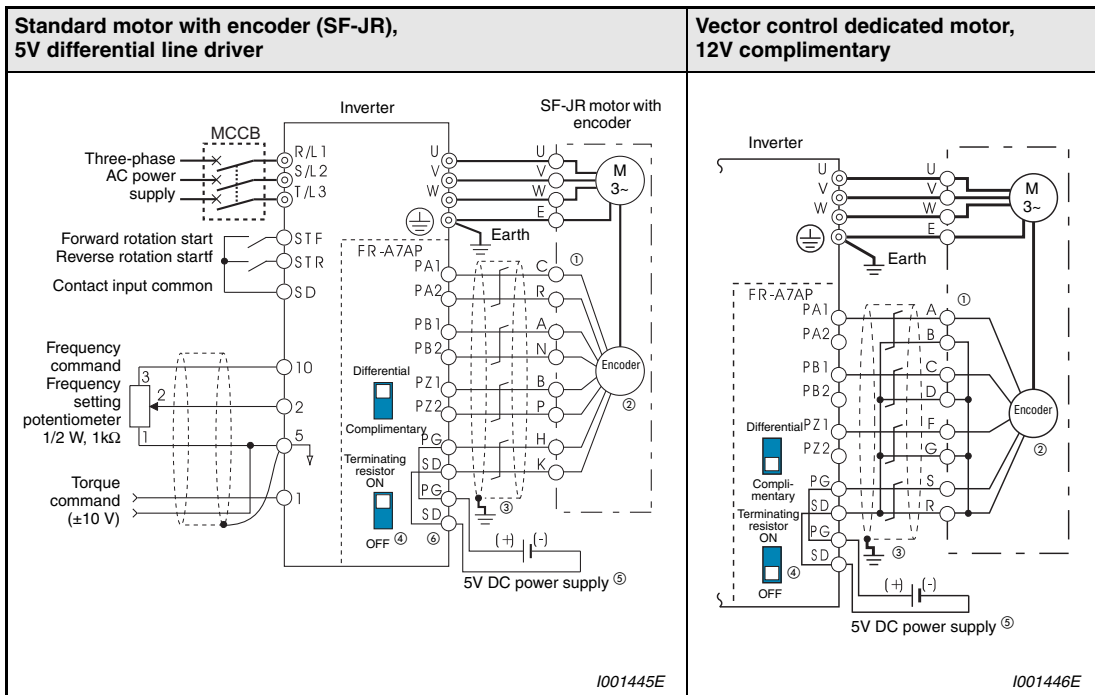

Tab. 3-17: Torque control

- ① The pin number differs according to the encoder used. Speed control and torque control are properly performed even without connecting Z phase.
- ② Connect the encoder so that there is no looseness between the motor and motor shaft. Speed ratio should be 1:1.
- ③ Earth (Ground) the shielded cable of the encoder cable to the enclosure with a P clip, etc. (Refer to page 3-41.)
- ④ For the complementary, set the terminating resistor selection switch to off position. (Refer to page 3-35.)
- ⑤ A separate power supply of 5V/12V/15V/24V is necessary according to the encoder power specification. When performing orientation control together, an encoder and power supply can be shared.
- ⑥ For terminal compatibility of the FR-JCBL and FR-A7AP, refer to page 3-37.

**NOTE**

The figure above shows the connection when using sink logic.

● Position control

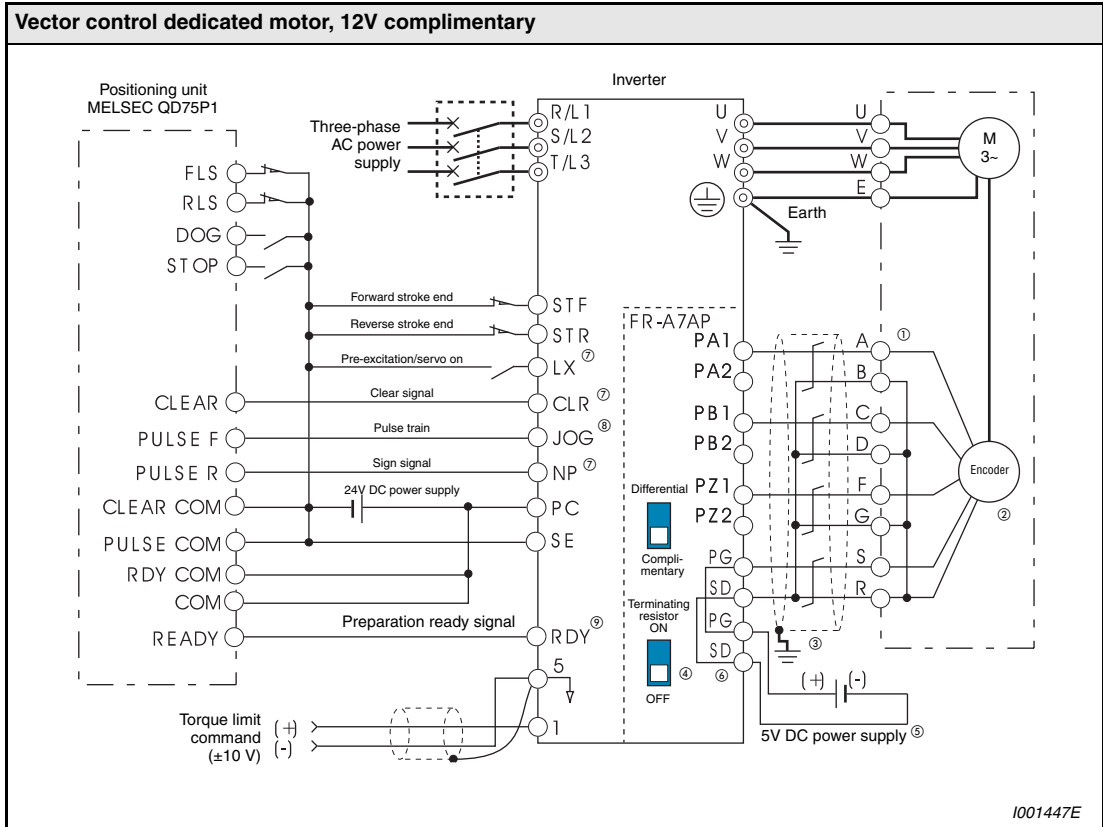

Tab. 3-18: Position control

- ① The pin number differs according to the encoder used. Speed control and torque control are properly performed even without connecting Z phase.
- ② Connect the encoder so that there is no looseness between the motor and motor shaft. Speed ratio should be 1:1.
- ③ Earth (Ground) the shielded cable of the encoder cable to the enclosure with a P clip, etc. (Refer to page 3-41.)
- ④ For the complementary, set the terminating resistor selection switch to off position. (Refer to page 3-35.)
- ⑤ A separate power supply of 5V/12V/15V/24V is necessary according to the encoder power specification. When performing orientation control together, an encoder and power supply can be shared.
- ⑥ For terminal compatibility of the FR-JCBL and FR-A7AP, refer to page 3-37.
- ⑦ Assign the function using Pr. 178 to Pr. 184, Pr. 187 to Pr. 189 "Input terminal function selection".
- ⑧ When position control is selected, terminal JOG function is made invalid and conditional position pulse train input terminal becomes valid.
- ⑨ Assign the function using Pr. 190 to Pr. 194 "Output terminal function selection".

**NOTE** | The figure above shows the connection when using sink logic.

**Instructions for encoder cable wiring**

Use twisted pair shield cables (0.2mm<sup>2</sup> or larger) to connect the FR-A7AP and position detector. Cables to terminals PG and SD should be connected in parallel or be larger in size according to the cable length.

To protect the cables from noise, run them away from any source of noise (e.g. the main circuit and power supply voltage).

Wiring Length	Paralell Connection		Larger-Size Cable
≤ 10m	At least 2 cables	Cable gauge 0.2mm <sup>2</sup>	≥ 0.4mm <sup>2</sup>
≤ 20m	At least 4 cables		≥ 0.75mm <sup>2</sup>
≤ 100m <sup>①</sup>	At least 6 cables		≥ 1.25mm <sup>2</sup>

**Tab. 3-19:** Cable gauges and number of paralell cables

① When differential line driver is set and a wiring length is 30m or more:  
 The wiring length can be extended to 100m by slightly increasing the power by 5V (approx. 5.5V) using six or more cables with gauge size of 0.2mm<sup>2</sup> in parallel or a cable with gauge size of 1.25mm<sup>2</sup> or more. Note that the voltage applied should be within power supply specifications of encoder.

To reduce noise of the encoder cable, earth (ground) the encoder shielded cable to the enclosure (as near as the inverter) with a P clip or U clip made of metal.

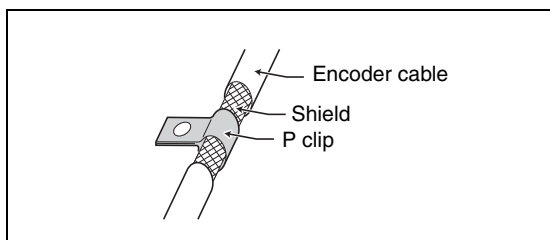

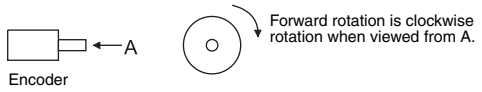

**Fig. 3-31:** Earthing (grounding) example using a P clip

1001448E

**NOTE**

For details of the optional encoder dedicated cable (FR-JCBL), refer to page 3-37.

**Parameter for encoder (Pr. 359, Pr. 369)**

Pr. No.	Name	Initial Value	Setting Range	Description
<b>359</b>	Encoder rotation direction	1	0	
			1	
<b>369</b>	Number of encoder pulses	1024	0-4096	Set the number of encoder pulses output. Set the number of pulses before it is multiplied by 4.

The above parameters can be set when the FR-A7AP (option) is mounted.

**Motor for vector control and parameter setting**

Motor		Pr. 9 Electronic thermal O/L relay	Pr. 71 Applied motor	Pr. 80 Motor capacity	Pr. 81 Number of motor poles	Pr. 359 Encoder rotation direction	Pr. 369 Number of encoder pulses
Mitsubishi stand- ard motor	SF-JR	Motor rated current	0	Motor capacity	Number of motor poles	1	1024
	SF-JR 4P 1.5 W or less	Motor rated current	20	Motor capacity	Number of motor poles	1	1024
	SF-HR	Motor rated current	40	Motor capacity	Number of motor poles	1	1024
	Others	Motor rated current	3 ①	Motor capacity	Number of motor poles	②	②
Mitsubishi con- stant torque motor	SF-JRCA 4P	Motor rated current	1	Motor capacity	4	1	1024
	SF-HRCA 4P	Motor rated current	15	Motor capacity	4	1	1024
	Others	Motor rated current	13 ①	Motor capacity	Number of motor poles	②	②
Mitsubishi vector control dedicated motor	SF-V5RU (1500 r/min)	0 ③	30	Motor capacity	4	1	2048
Other manufac- turer's standard motor	—	Motor rated current	3 ①	Motor capacity	Number of motor poles	②	②
Other manufac- turer's constant torque motor	—	Motor rated current	13 ①	Motor capacity	Number of motor poles	②	②

**Tab. 3-20: Motor for vector control and parameter setting**

Values in the bolded frame are initial values.

- ① Offline auto tuning is necessary. (Refer to section 6.12.3.)
- ② Set this parameter according to the motor (encoder) used.
- ③ Use thermal protector input provided with the motor.

**Reference**

- Vector control (speed control) ⇒ refer to section 6.3.2
- Vector control (torque control) ⇒ refer to section 6.4.2
- Vector control (position control) ⇒ refer to section 6.5.1
- Orientation control ⇒ refer to section 6.13.6
- Encoder feedback control ⇒ refer to section 6.24.6

## 3.8 Connection of stand-alone option units

The inverter accepts a variety of stand-alone option units as required.



**CAUTION:**

***Incorrect connection will cause inverter damage or accident. Connect and operate the option unit carefully in accordance with the corresponding option unit manual.***

### 3.8.1 Magnetic contactors (MC)

#### Inverter input side magnetic contactor (MC)

On the inverter input side, it is recommended to provide an MC for the following purposes.

- To release the inverter from the power supply when the inverter's protective function is activated or when the drive is not functioning (e.g. emergency operation).
- To prevent any accident due to an automatic restart at restoration of power after an inverter stop made by a power failure.
- The control power supply for inverter is always running and consumes a little power. When stopping the inverter for an extended period of time, powering off the inverter will save power slightly.
- To separate the inverter from the power supply to ensure safe maintenance and inspection work. The inverter's input side MC is used for the above purpose, select class JEM1038-AC3MC for the inverter input side current when making an emergency stop during normal operation.

**NOTE**

Since repeated inrush currents at power on will shorten the life of the converter circuit (switching life is about 1,000,000 times.), frequent starts and stops of the MC must be avoided. Turn on/off the inverter start controlling terminals (STF, STR) to run/stop the inverter.

**Example** ▽

As shown below, always use the start signal (ON or OFF across terminals STF or STR-PC) to make a start or stop. (Refer to section 6.14.4.)

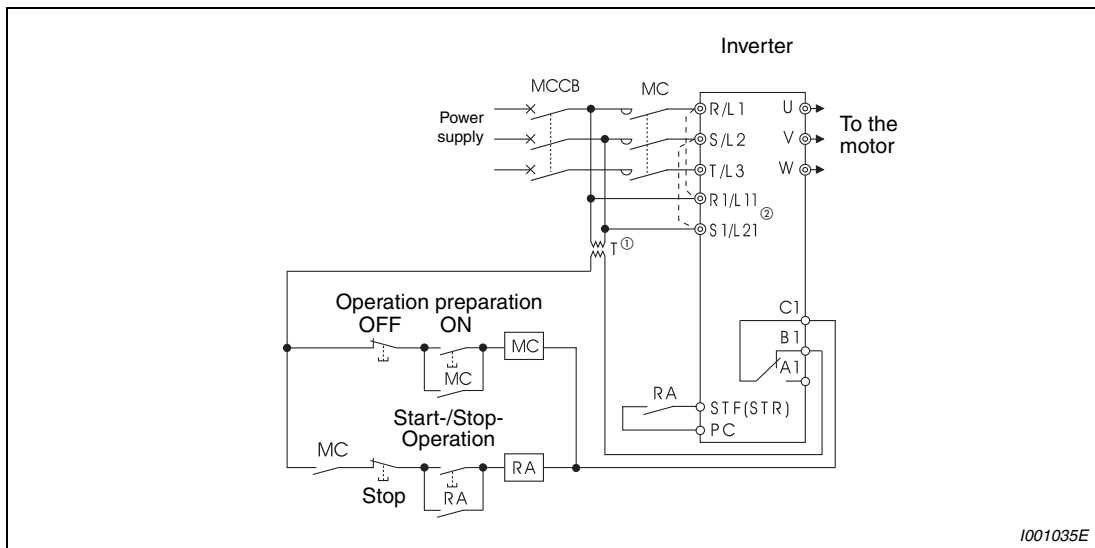

**Fig. 3-32:** Start and stop of the inverter

- ① When the power supply is 400V class, install a step-down transformer.
- ② Connect the power supply terminals R1/L11, S1/L21 of the control circuit to the primary side of the MC to hold an alarm signal when the inverter's protective circuit is activated. At this time, remove jumpers across terminals R/L1-R1/L11 and S/L2-S1/L21. (Refer to section 3.3.3.)



**Handling of the inverter output side magnetic contactor**

Switch the magnetic contactor between the inverter and motor only when both the inverter and motor are at a stop. When the magnetic contactor is turned on while the inverter is operating, over current protection of the inverter and such will activate. When an MC is provided to switch to a commercial power supply, for example, it is recommended to use commercial power supply-inverter switch over operation Pr. 135 to Pr. 139.

### 3.8.2 Connection of the dedicated external brake resistor (FR-ABR)

The built-in brake resistor of the inverters 00620 or less is connected across terminals P/+ and PR. Fit the external dedicated brake resistor (FRABR) when the built-in brake resistor does not have enough thermal capability for high-duty operation. At this time, remove the jumper from across terminals PR-PX (00250 or less) and connect the dedicated brake resistor (FR-ABR) across terminals P/+ -PR.

(For the locations of terminal P/+ and PR, refer to the terminal block layout (section 3.3.2).) Removing jumpers across terminal PR-PX disables the built-in brake resistor (power is not supplied). Note that the built-in brake resistor is not need to be removed from the inverter. The lead wire of the built-in brake resistor is not need to be removed from the terminal. Set parameters below.

- Pr. 30 "Regenerative function selection" = 1
- Pr. 70 "Special regenerative brake duty" = 00250 or less: 10%, 00310 or more: 6% (Refer to section 6.13.2.)



**CAUTION:**

- *The brake resistor connected should only be the dedicated brake resistor.*
- *The jumper across terminals PR-PX (00250 or less) must be disconnected before connecting the dedicated brake resistor. Doing so may damage the inverter.*

#### FR-A740-00023 to 00126

- ① Remove the screws in terminals PR and PX and remove the jumper.
- ② Connect the brake resistor across terminals P/+ and PR. (The jumper should remain disconnected.)

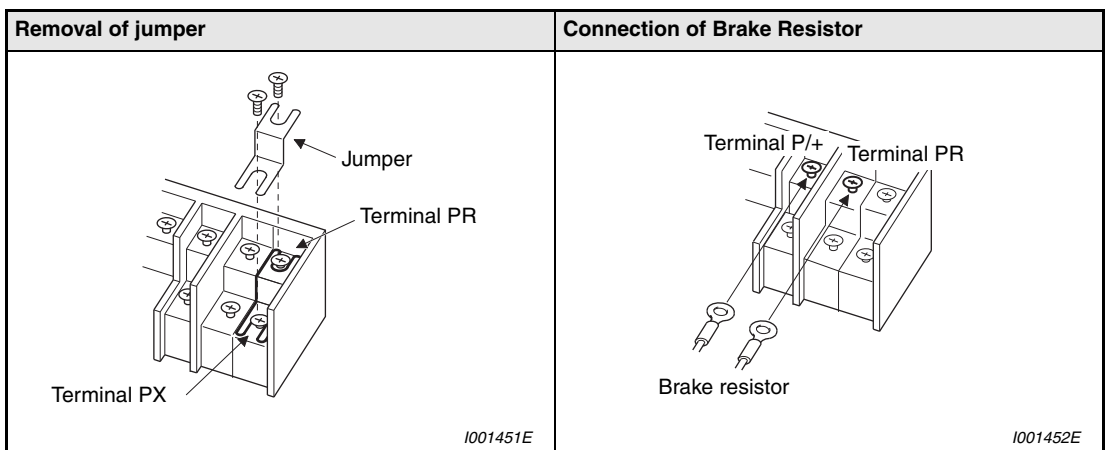

**Tab. 3-21:** Connection of the external brake resistor (00023 to 00126)

**FR-A740-00170 and 00250**

- ① Remove the screws in terminals PR and PX and remove the jumper.
- ② Schließen Sie den Bremswiderstand an den Klemmen P/+ und PR an. (Die Brücke muss abgeklemmt bleiben.)

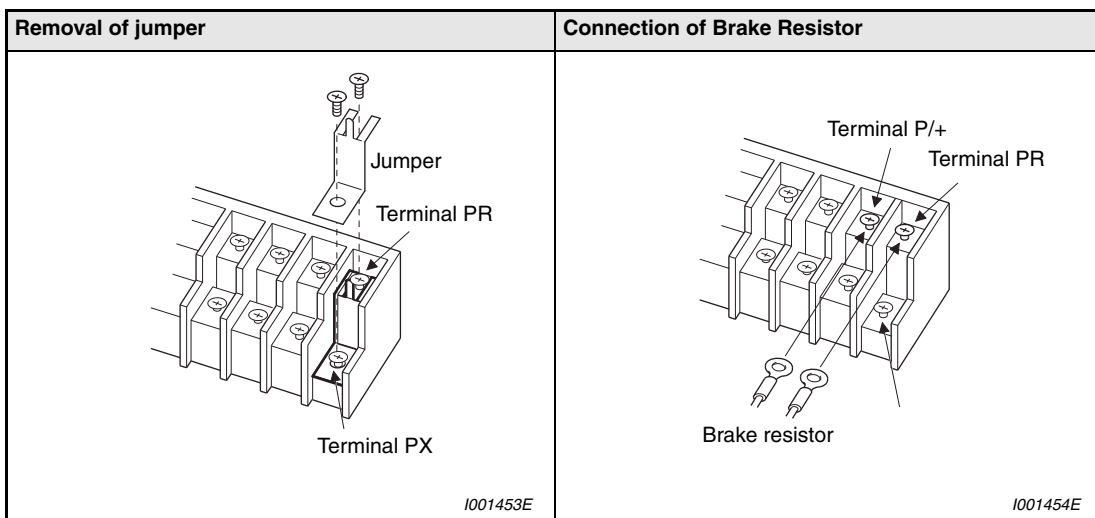

**Tab. 3-22:** Connection of the external brake resistor (00170 to 00250)

**FR-A740-00310 to 00620**

- ① Connect the brake resistor across terminals P/+ and PR.

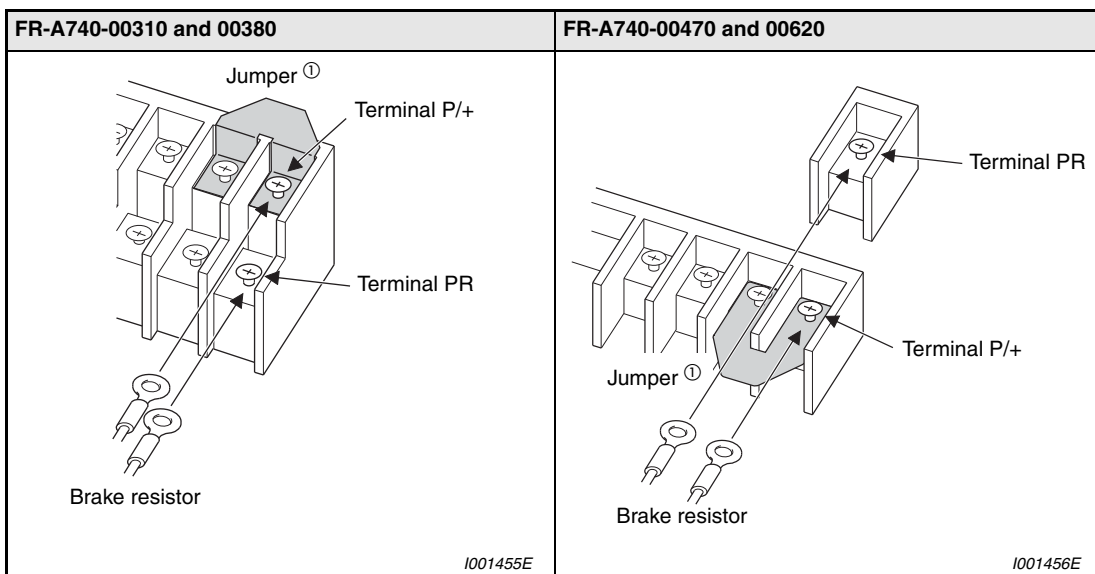

**Tab. 3-23:** Connection of the external brake resistor (00310 to 00620)

Do not remove a jumper across terminal P/+ and P1 except when connecting a DC reactor.



When the regenerative brake transistor is damaged, the following sequence is recommended to prevent overheat and burnout of the brake resistor.

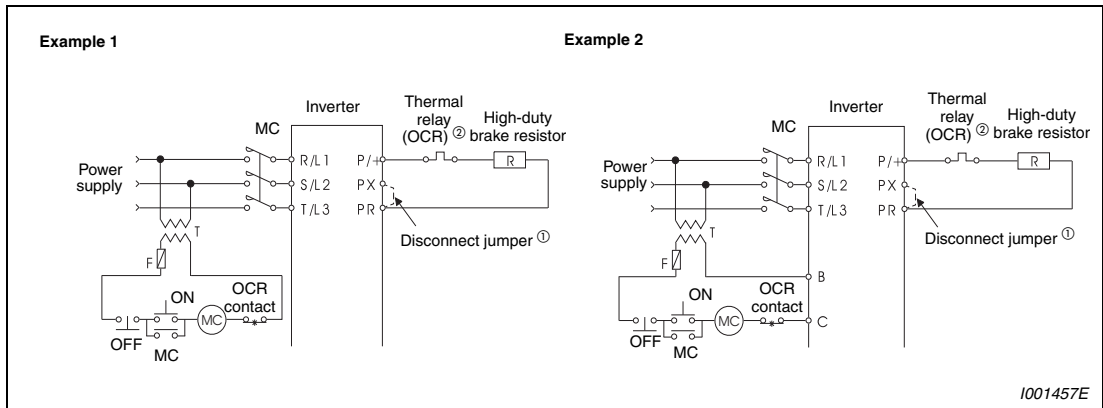
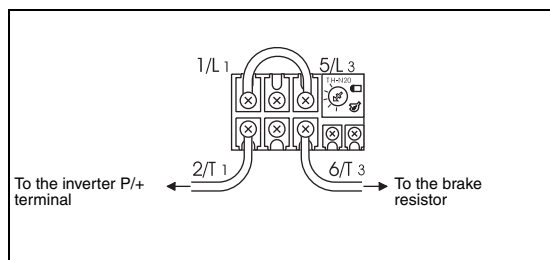

**Fig. 3-33: Protective circuit**

- ① Since the 00310 or more inverter is not provided with the PX terminal, a jumper is not need to be removed.
- ② Refer to the table below for the type number of each capacity of thermal relay and the diagram below for the connection. (Always install a thermal relay when using the 00310 or more.)

Power Supply Voltage	High-Duty Brake Resistor	Thermal Relay Type	Contact Rating
400V	FR-ABR-H0.4K	TH-N20CXHZKP-0.24A	110V/5A AC, 220V/2A AC (AC 11 class), 110V/0.5A DC, 220V/0.25A DC (DC 11 class)
	FR-ABR-H0.75K	TH-N20CXHZKP-0.35A	
	FR-ABR-H2.2K	TH-N20CXHZKP-0.9A	
	FR-ABR-H3.7K	TH-N20CXHZKP-1.3A	
	FR-ABR-H5.5K	TH-N20CXHZKP-2.1A	
	FR-ABR-H7.5K	TH-N20CXHZKP-2.5A	
	FR-ABR-H11K	on request	
	FR-ABR-H15K	on request	
	FR-ABR-H22K	on request	

**Tab. 3-24: Combination of resistor and thermal relay**



**Fig. 3-34: Connection of th thermal relay**

I001458E

### 3.8.3 Connection of a brake unit

When connecting a brake unit to improve the brake capability at deceleration, make connection as shown below.

#### Connection with the brake unit FR-BU (01800 or less)

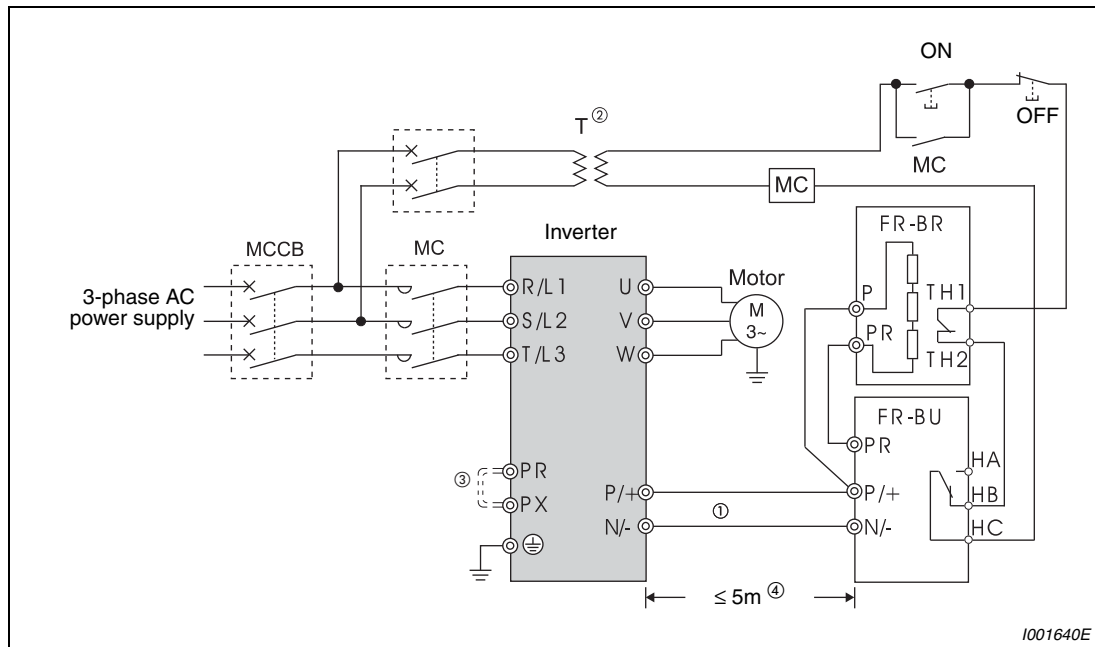

**Fig. 3-35:** Connection with the brake unit FR-BU

- ① Connect the inverter terminals (P/+, N/-) and brake unit terminals so that their terminal signals match with each other. (Incorrect connection will damage the inverter.)
- ② If the control contacts are only specified for 230V control power you must install a transformer when using a 400V power supply.
- ③ Be sure to remove a jumper across terminal PR-PX when using the FR-BU with the inverter of 00250 or less.
- ④ The wiring distance between the inverter, brake unit and resistor unit should be within 5m. If twisted wires are used, the distance should be within 10m.



**CAUTION:**

***If the transistors in the brake unit should become faulty, the resistor can be unusually hot, causing a fire. Therefore, install a magnetic contactor on the inverters input side to configure a circuit so that a current is shut off in case of fault.***

### Connection with the brake unit MT-BU5 (02160 or more)

After making sure that the wiring is correct, set "1" in Pr. 30 "Regenerative function selection" and "10%" in Pr. 70 "Special regenerative brake duty". (Refer to section 6.13.2.)

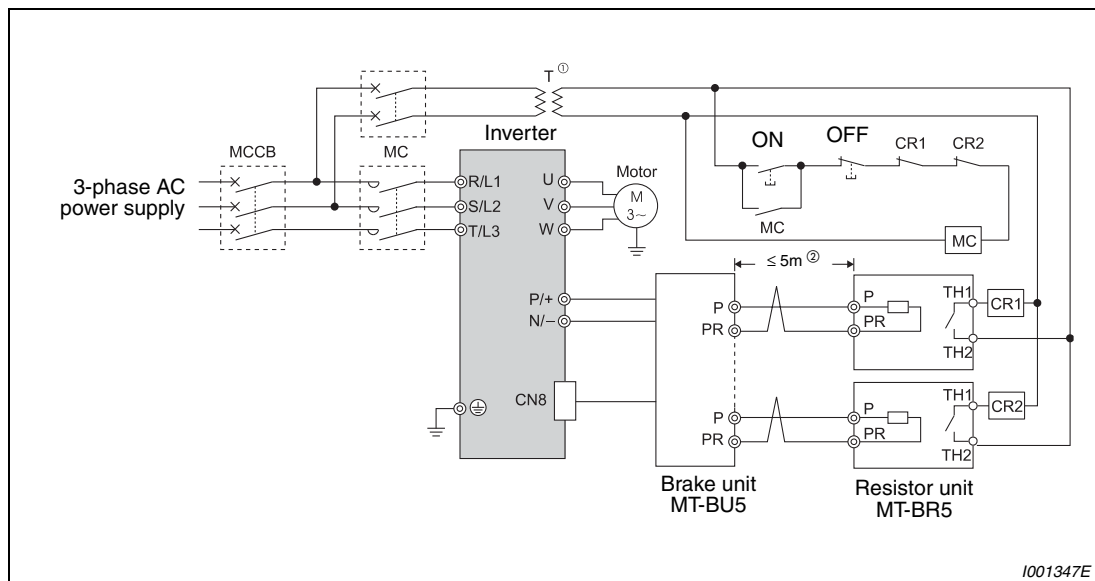

**Fig. 3-36:** Connection with the brake unit MT-BU5

- ① If the control contacts are only specified for 230V control power you must install a transformer when using a 400V power supply.
- ② The wiring distance between the inverter, brake unit and resistor unit should be within 5m. If twisted wires are used, the distance should be within 10m.



#### CAUTION:

- Install the brake unit in a place where a cooling air reaches the brake unit heatsink and within a distance of the cable supplied with the brake unit reaches the inverter.
- For wiring of the brake unit and inverter, use an accessory cable supplied with the brake unit. Connect the main circuit cable to the inverter terminals P/+ and N/- and connect the control circuit cable to the CN8 connector inside by making cuts in the rubber bush at the top of the inverter for leading the cable.
- The brake unit which uses multiple resistor units has terminals equal to the number of resistor units. Connect one resistor unit to one pair of terminal (P, PR).

**Inserting the CN8 connector**

- ① Make cuts in the rubber bush for leading the CN8 connector cable with a nipper or cutter knife.

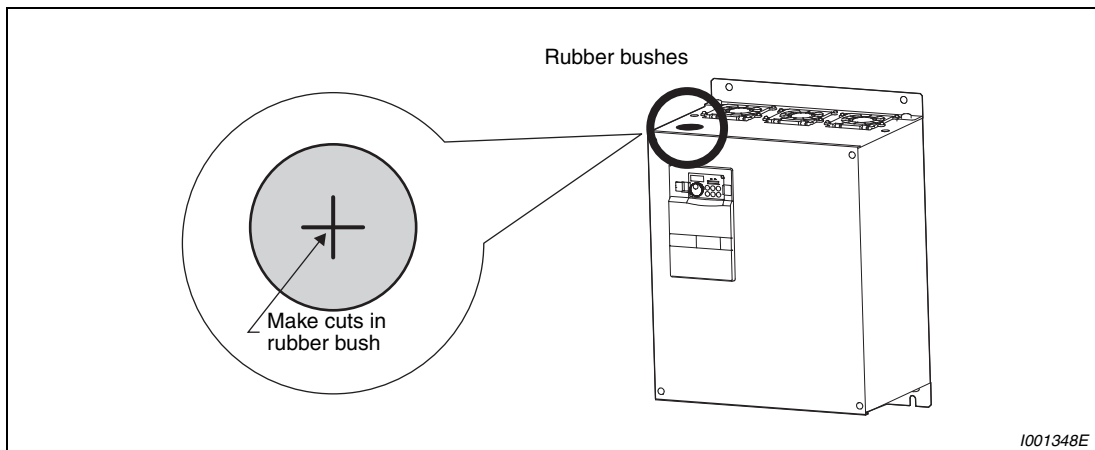

**Fig. 3-37:** Rubber bush

- ② Insert a connector on the MT-BU5 side through a rubber bush to connect to a connector on the inverter side.

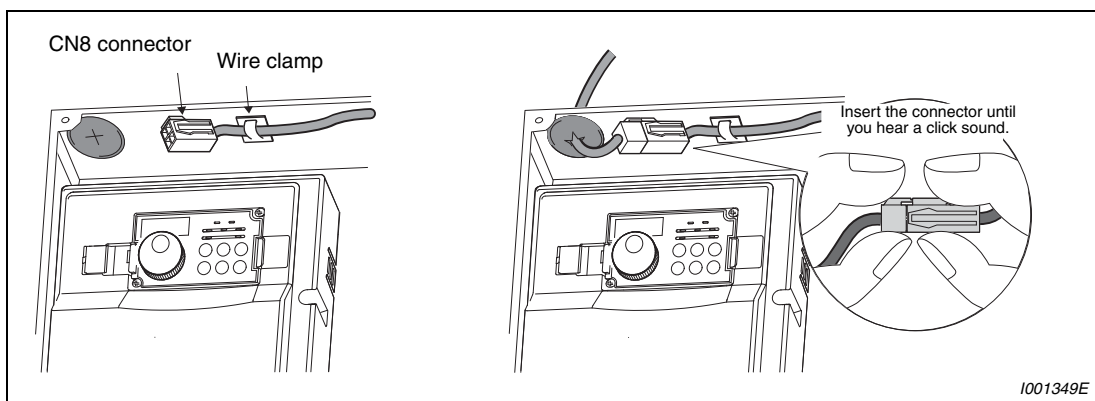

**Fig. 3-38:** Connection of the CN8 connector

- ③ Clamp the CN8 connector cable on the inverter side with a wire clamp securely.



**CAUTION:**  
Do not connect the MT-BU5 to a CN8 connector of the FR-A740-01800.

### 3.8.4 Connection of the high power factor converter (FR-HC, MT-HC)

When connecting the high power factor converter (FR-HC) to suppress power harmonics, perform wiring securely as shown below.



**CAUTION:**

**Perform wiring of the high power factor converter (FR-HC) securely as shown below. Incorrect connection will damage the high power factor converter and inverter.**

After making sure that the wiring is correct, set "2" in Pr. 30 "Regenerative function selection" (Refer to section 6.13.2.)

#### Connection with the FR-HC (01800 or less)

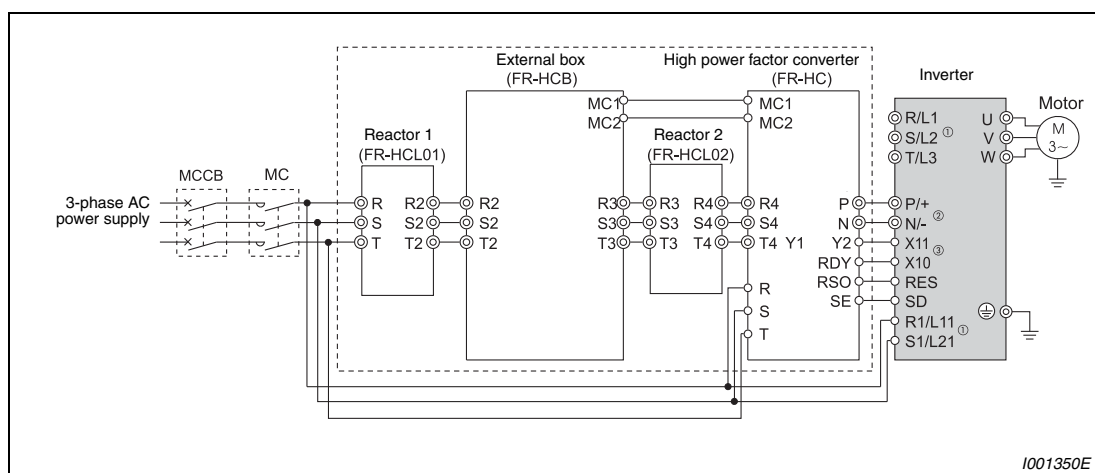

**Fig. 3-39:** Connection of the high power factor converter FR-HC

- ① Remove the jumpers across the inverter terminals R/L1-R1/L11, S/L2-S1/L21, and connect the control circuit power supply to the R1/L11 and S1/L21 terminals. Always keep the power input terminals R/L1, S/L2, T/L3 open. Incorrect connection will damage the inverter. (E.OPT (option alarm) will occur. (Refer to page 7-16.)
- ② Do not insert the MCCB between terminals P/+-N/- (P/+-P/+, N/--N/-). Opposite polarity of terminals N/-, P/+ will damage the inverter.
- ③ Use Pr. 178 to Pr. 189 "input terminal function selection" to assign the terminals used for the X10 (X11) signal. (Refer to section 6.14.1.)  
For communication where the start command is sent only once, e.g. RS-485 communication operation, use the X11 signal when making setting to hold the mode at occurrence of an instantaneous power failure. (Refer to section 6.13.2.)

**NOTES**

The voltage phases of terminals R/L1, S/L2, T/L3 and terminals R4, S4, T4 must be matched.

Use sink logic when the FR-HC is connected. The FR-HC cannot be connected when source logic (factory setting) is selected.

**Connection with the MT-HC (02160 or more)**

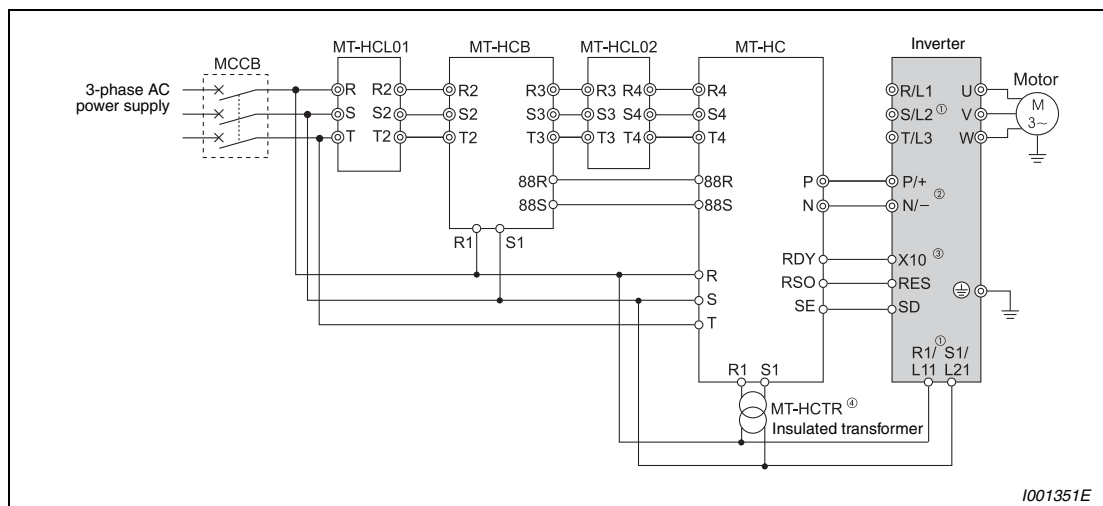

**Fig. 3-40: Connection with the MT-HC**

- ① Remove the jumper across terminals R-R1, S-S1 of the inverter, and connect the control circuit power supply to the R1 and S1 terminals. The power input terminals R/L1, S/L2, T/L3 must be open. Incorrect connection will damage the inverter. (E.OPT (option alarm) will occur. (Refer to page 7-17.)
- ② Do not insert the MCCB between terminals P/+-N/- (P/+-P/+, N/--N/-). Opposite polarity of terminals N, P will damage the inverter.
- ③ Use Pr. 178 to Pr. 189 "Input terminal function selection" to assign the terminals used for the X10 (X11) signal. (Refer to section 6.14.1.)  
For communication where the start command is sent only once, e.g. RS-485 communication operation, use the X11 signal when making setting to hold the mode at occurrence of an instantaneous power failure. (Refer to section 6.13.2.)
- ④ Connect the power supply to terminals R1 and S1 of the MT-HC via an insulated transformer.

**NOTES**

- The voltage phases of terminals R/L1, S/L2, T/L3 and terminals R4, S4, T4 must be matched.
- Use sink logic when the MT-HC is connected. The MT-HC cannot be connected when source logic (factory setting) is selected.
- When connecting the inverter to the MT-HC, do not connect the DC reactor provided to the inverter.

### 3.8.5 Connection of the power regeneration common converter FR-CV (01800 or less)

When connecting the power regeneration common converter (FR-CV), make connection so that the inverter terminals (P/+, N/-) and the terminal symbols of the power regeneration common converter (FR-CV) are the same.

After making sure that the wiring is correct, set "2" in Pr. 30 "Regenerative function selection". (Refer to section 6.13.2).

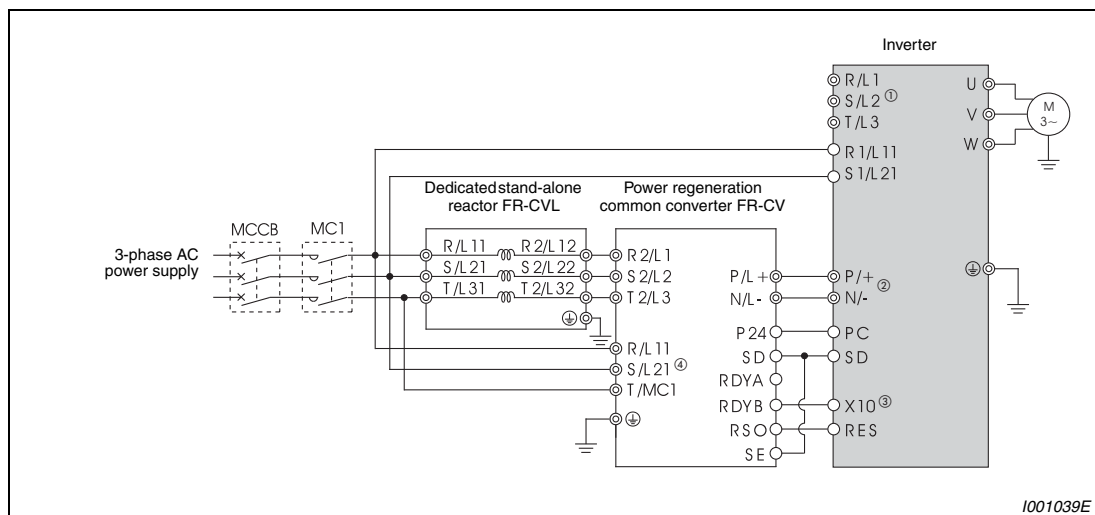

**Fig. 3-41:** Connection of the power regeneration common converter FR-CV

- ① Remove the jumpers across the inverter terminals R/L1-R1/L11, S/L2-S1/L21, and connect the control circuit power supply to the R1/L11 and S1/L21 terminals. Always keep the power input terminals R/L1, S/L2, T/L3 open. Incorrect connection will damage the inverter. (E.OPT (option alarm) will occur. (Refer to page 7-16.)
- ② Do not insert the MCCB between terminals P/+ - N/- (P/L+ - P/+, N/L- - N/-). Opposite polarity of terminals N/-, P/+ will damage the inverter.
- ③ Assign the terminal for X10 signal using any of Pr. 178 to Pr. 189 "input terminal function selection". (Refer to section 6.14.1.)
- ④ Be sure to connect the power supply and terminals R/L11, S/L21, T/MC1. Operating the inverter without connecting them will damage the power regeneration common converter.

#### NOTES

The voltage phases of terminals R/L11, S/L21, T/MC1 and terminals R2/L1, S2/L2, T2/L3 must be matched.

Use sink logic when the FR-CV is connected. The FR-CV cannot be connected when source logic (factory setting) is selected.

### 3.8.6 Connection of power regeneration converter (MT-RC) (02160 or more)

When connecting a power regeneration converter (MT-RC), perform wiring securely as shown below.



**CAUTION:**  
**Perform wiring of the power regeneration converter (MT-RC) securely as shown below. Incorrect connection will damage the power regeneration converter and inverter.**

After connecting securely, set "1" in Pr. 30 "Regenerative function selection" and "0" in Pr. 70 "Special regenerative brake duty".

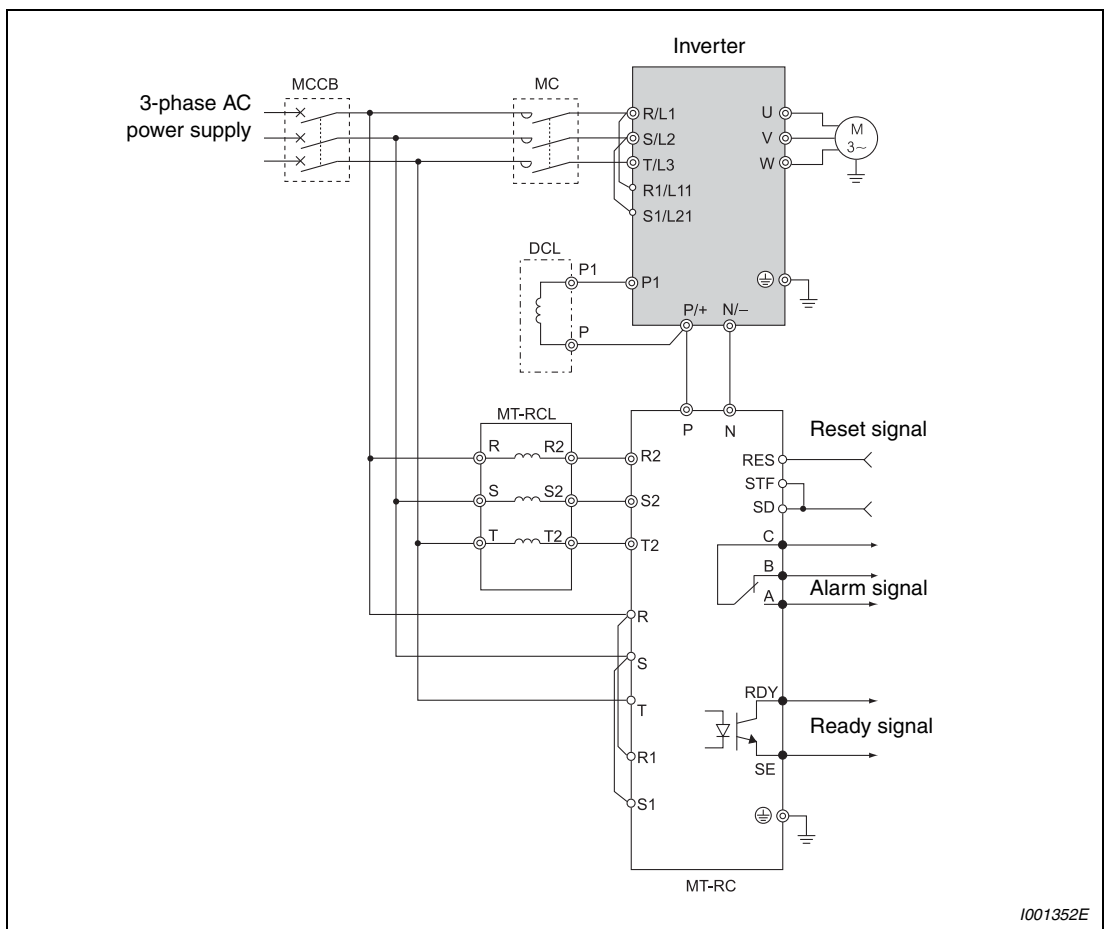

**Fig. 3-42:** Connection of the power regeneration converter MT-RC

**NOTE**

Refer to the MT-RC manual for precautions for connecting the power coordination reactor and others.



### 3.8.7 Connection of the power improving DC reactor FR-HEL

When using the DC reactor (FR-HEL), connect it between terminals P1-P/+. For the 01160 or less, the jumper connected across terminals P1-P/+ must be removed. Otherwise, the reactor will not exhibit its performance.

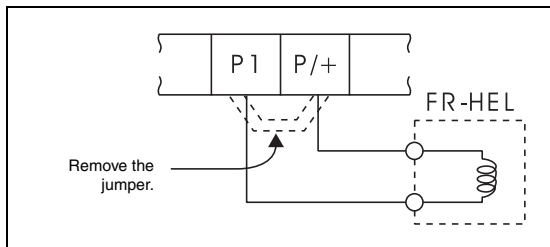

**Fig. 3-43:**  
Connection of a DC reactor

1001040E

**NOTES**

- | The wiring distance should be within 5m.
- | The size of the cables used should be equal to or larger than that of the power supply cables (R/L1, S/L2, T/L3). (Refer to page 3-12.)
- | For inverters  $\geq 01800$  the supplied DC reactor has to be installed to the mentioned terminals.

### 3.8.8 Installation of a reactor

When the inverter is connected near a large-capacity power transformer (1000kVA or more) or when a power capacitor is to be switched over, an excessive peak current may flow in the power input circuit, damaging the converter circuit. To prevent this, always install the optional DC reactor (FR-HEL) or AC reactor (FR-BAL-B).

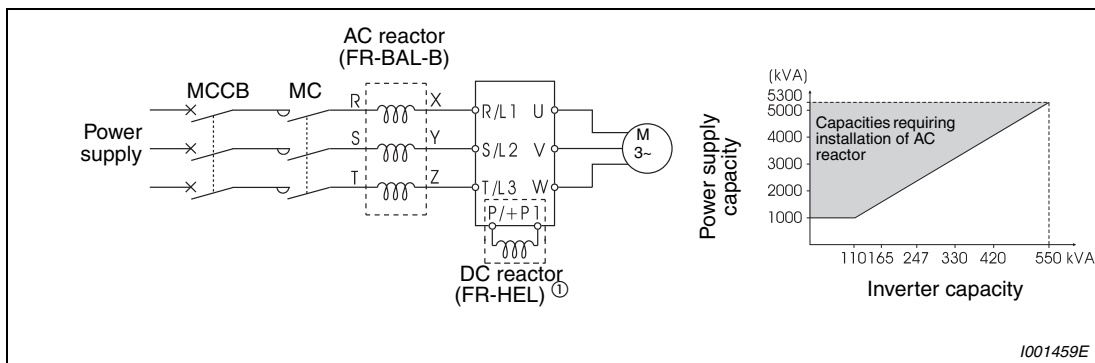

1001459E

**Fig. 3-44:** Installation of a reactor

① When connecting the FR-HEL to the 01160 or less, remove the jumper across terminals P-P1. For the 01800 or more, a DC reactor is supplied. Always install the reactor.

**NOTES**

- | The wiring length between the FR-HEL and inverter should be 5m maximum and minimized.
- | Use the same wire size as that of the power supply wire (R/L1, S/L2, T/L3). (Refer to page 3-12).

## 3.9 Electromagnetic compatibility (EMC)

### 3.9.1 Leakage currents and countermeasures

Mains filters, shielded motor cables, the motor, and the inverter itself cause stationary and variable leakage currents to PE. Since its value depends on the capacitances, carrier frequency, etc., low acoustic noise operation at the increased carrier frequency of the inverter will increase the leakage current. Therefore, take the following measures. Select the earth leakage breaker according to its rated sensitivity current, independently of the carrier frequency setting.

#### To-earth (ground) leakage currents

Leakage currents may flow not only into the inverter's own line but also into the other lines through the earth (ground) cable, etc. These leakage currents may operate earth (ground) leakage circuit breakers and earth leakage relays unnecessarily.

##### ● Countermeasures

- If the carrier frequency setting is high, decrease the Pr. 72 "PWM frequency selection" setting. Note that motor noise increases. Selecting Pr. 240 "Soft-PWM operation selection" makes the sound inoffensive.
- By using earth leakage circuit breakers designed for harmonic and surge suppression in the inverter's own line and other line, operation can be performed with the carrier frequency kept high (with low noise).

##### ● To-earth leakage currents

- Take caution as long wiring will increase the leakage current. Decreasing the carrier frequency of the inverter reduces the leakage current.
- Increasing the motor capacity increases the leakage current.
- Shielded motor cables significantly increase the leakage current to PE (approx. double the value generated with unshielded motor cables of the same length).

#### Line-to-line leakage currents

Harmonics of leakage currents flowing in static capacities between the inverter output cables may operate the external thermal relay unnecessarily. When the wiring length is long (50m or more) for the small-capacity model (FR-A700-00250 or less), the external thermal relay is likely to operate unnecessarily because the ratio of the leakage current to the rated motor current increases.

#### Example ▾

Line-to-line leakage current data example  
 Dedicated motor: SF-JR 4P  
 Carrier frequency: 14.5kHz  
 Used wire: 2.5mm<sup>2</sup>, 4 cores, cab tyre cable

Motor Capacity [kW]	Rated Motor Current [A]	Leakage Currents [mA]	
		Wiring length 50m	Wiring length 100m
0.4	1.1	620	1000
0.75	1.9	680	1060
1.5	3.5	740	1120
2.2	4.1	800	1180
3.7	6.4	880	1260
5.5	9.7	980	1360
7.5	12.8	1070	1450

**Tab. 3-25:** Line-to-line leakage current data example



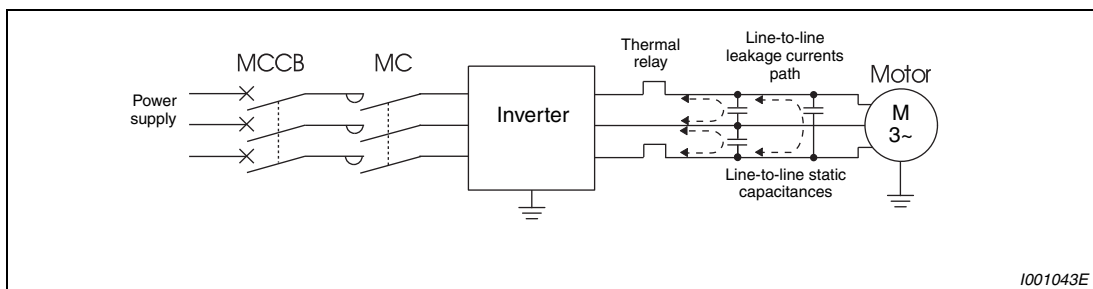

**Fig. 3-45:** Line-to-line leakage currents

- Countermeasures
  - Use Pr. 9 "Electronic thermal O/L relay".
  - If the carrier frequency setting is high, decrease the Pr. 72 "PWM frequency selection" setting. Note that motor noise increases. Selecting Pr. 240 "Soft-PWM operation selection" makes the sound inoffensive. To ensure that the motor is protected against line-to-line leakage currents, it is recommended to use a temperature sensor (e.g. PTC element) to directly detect motor temperature.
- Selecting a power supply circuit breaker:
 

You can also use a circuit breaker (MCCB) to protect the power supply lines against short circuits and overloads. However, note that this does not protect the inverter (rectifiers, IGBT). Select the capacity of the circuit breaker on the basis of the cross-sectional area of the power supply lines. To calculate the required mains current trip point you need to know the power required by the inverter (Refer to Rated Input Capacity in Appendix A, Specifications) and the mains supply voltage. Select a circuit breaker with a trip point that is slightly higher than calculated, particularly in the case of breakers with electromagnetic tripping, since the trip characteristics are strongly influenced by the harmonics in the power supply line.

#### NOTES

The earth leakage breaker must be either a Mitsubishi earth leakage breaker (ELB, for harmonics and surges) or an ELB with breaker designed for harmonic and surge suppression that is approved for use with frequency inverters.

**Note on selecting a suitable power supply ELCB**

If you install a Mitsubishi frequency inverter with a 3-phase power supply in locations where an earth leakage contact breaker is required by the VDE you must install a universal-current sensitive ELCB conforming to the specifications laid down in VDE 0160 / EN 50178 (ELCB Type B). This is necessary because pulse-current sensitive ELCBs (Type A) do not provide reliable tripping performance for the frequency inverter in response to DC leakage current.

When selecting a suitable universal-current sensitive ELCB you must also take into account the influence of the mains filter, the length of the shielded motor power cables and the frequency on the leakage currents.

Also note that when the mains power is switched on with switches without a snap-action function the resulting brief asymmetrical load can cause unwanted triggering of the ELCB.

This problem can be avoided by using a Type B ELCB with a delayed response function, or by using a contactor relay to switch all three phases simultaneously.

Calculate the trip current sensitivity of the ELCB as follows:

- Breaker designed for harmonic and surge suppression:  

$$I_{\Delta n} \geq 10 \times (I_{g1} + I_{gn} + I_{gi} + I_{g2} + I_{gm})$$
- Standard breaker:  

$$I_{\Delta n} \geq 10 \times [I_{g1} + I_{gn} + I_{gi} + 3 \times (I_{g2} + I_{gm})]$$

$I_{g1}$ ,  $I_{g2}$ : Leakage currents in wire path during commercial power supply operation

$I_{gn}$ : Leakage current of inverter input side noise filter

$I_{gm}$ : Leakage current of motor during commercial power supply operation

$I_{gi}$ : Leakage current of inverter unit

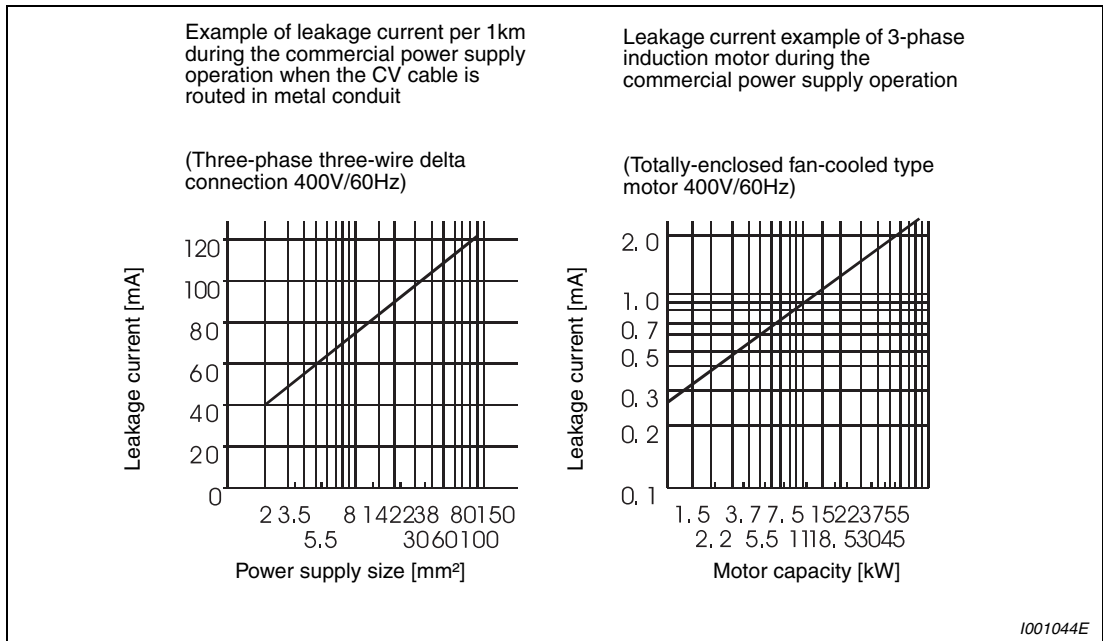
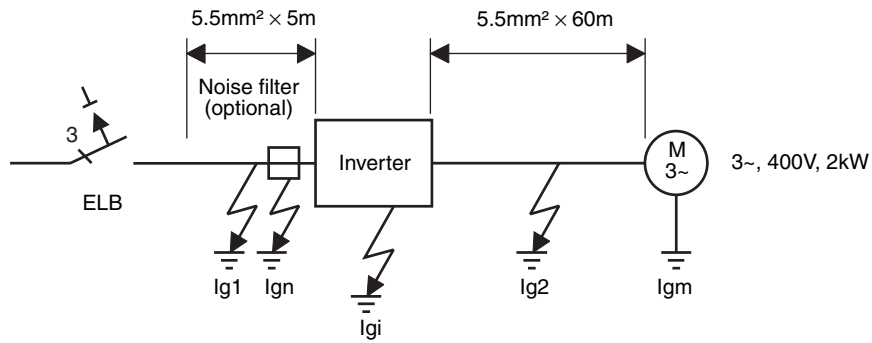

**Fig. 3-46: Leakage currents**

**NOTE**

For star connection, the amount of leakage current is 1/3.

**Example** ▽



	Breaker Designed for Harmonic and Surge Suppression	Standard Breaker
Leakage current Ig1 [mA]	$\frac{1}{3} \times 66 \times \frac{5 \text{ m}}{1000 \text{ m}} \approx 0.11$	
Leakage current Ign [mA]	0 (without additional noise filter)	
Leakage current Igi [mA]	1 (with additional noise filter) Refer to the following table for the leakage current of the inverter ①.	
Leakage current Ig2 [mA]	$\frac{1}{3} \times 66 \times \frac{60 \text{ m}}{1000 \text{ m}} \approx 1.32$	
Motor leakage current Igm [mA]	0.36	
Total leakage current [mA]	2.79	6.15
Rated sensivity current [mA] ( $\geq I_g \times 10$ )	30	100

**Tab. 3-26: Estimation of the permanent flowing leakage current**

① Refer to section 3.9.3 for the presence/absence of the built-in EMC filter.

Inverter leakage current (with and without EMC filter)

Input power conditions (400V class: 440V/60Hz, power supply unbalance within 3%)

	Voltage [V]	Built-in EMC Filter	
		ON [mA]	OFF [mA]
Phase grounding 	400	30	1
Earth-neutral system 	400	1	1

**Tab. 3-27: Inverter leakage current (with and without built-in EMC filter)**



**NOTES**

The frequency inverter monitors its own output for ground faults up to a frequency of 120Hz. However, it is important to understand that this feature only protects the inverter itself. It cannot be used to provide protection against shock hazards for personnel.

In the connection earthed-neutral system, the sensitivity current is purified against an earth fault in the inverter output side. Earthing must conform to the requirements of national and local safety regulations and electrical codes. (JIS, NEC section 250, IEC 536 class 1 and other applicable standards)

When the breaker is installed on the output side of the inverter, it may be unnecessarily operated by harmonics even if the effective value is less than the rating. In this case, do not install the breaker since the eddy current and hysteresis loss will increase, leading to temperature rise.

The following models are standard breakers: BV-C1, BC-V, NVB, NV-L, NV-G2N, NV-G3NA and NV-2F earth leakage relay (except NV-ZHA), NV with AA neutral wire open-phase protection.

The other models are designed for harmonic and surge suppression: NV-C/NV-S/MN series, NV30-FA, NV50-FA, BV-C2, earth leakage alarm breaker (NF-Z), NV-ZHA, NV-H

### 3.9.2 Inverter-generated noises and their reduction techniques

Some noises enter the inverter to malfunction it and others are radiated by the inverter to malfunction peripheral devices. Though the inverter is designed to be insusceptible to noises, it handles low-level signals, so it requires the following basic techniques. Also, since the inverter chops outputs at high carrier frequency, that could generate noises. If these noises cause peripheral devices to malfunction, measures should be taken to suppress noises.

These techniques differ slightly depending on noise propagation paths.

- Basic techniques

- Do not run the power cables (I/O cables) and signal cables of the inverter in parallel with each other and do not bundle them.
- Use twisted pair shielded cables for the detector connection and control signal cables. Earth the shield.
- Earth the inverter, motor, etc. at one point.

- Techniques to reduce noises that enter and malfunction the inverter

When devices that generate many noises (which use magnetic contactors, magnetic brakes, many relays, for example) are installed near the inverter and the inverter may be malfunctioned by noises, the following measures must be taken:

- Provide surge suppressors for devices that generate many noises to suppress noises.
- Fit data line filters to signal cables.
- Earth the shields of the detector connection and control signal cables with cable clamp metal.

- Techniques to reduce noises that are radiated by the inverter to malfunction peripheral devices

Inverter-generated noises are largely classified into:

- those radiated by the cables connected to the inverter and inverter main circuits (I/O),
- those electromagnetically and electrostatically induced to the signal cables of the peripheral devices close to the main circuit power supply,
- and those transmitted through the power supply cables.

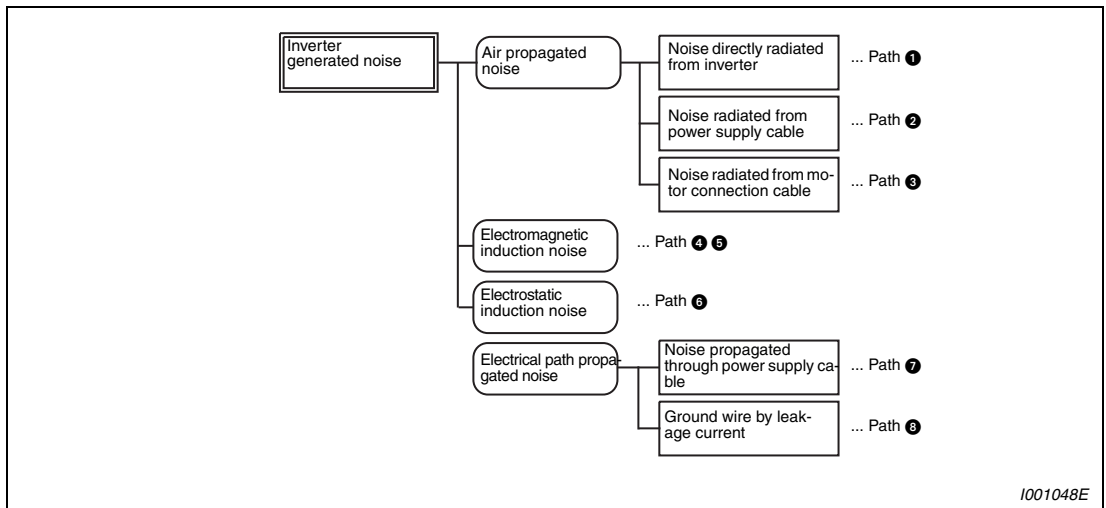

Fig. 3-47: Noise propagation

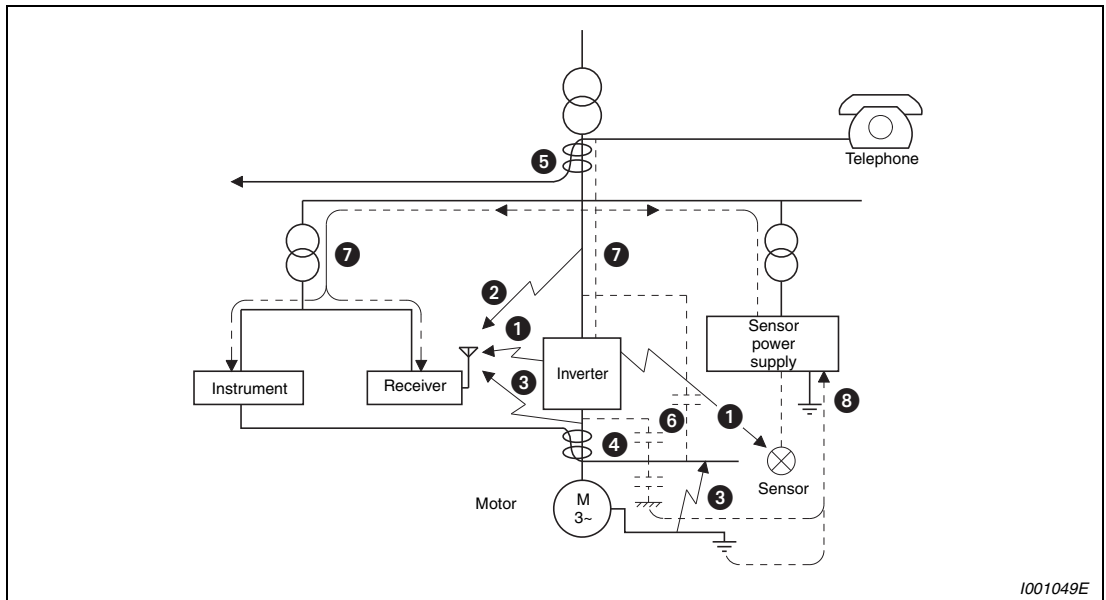

Fig. 3-48: Noise paths



Noise Propagation Path	Measures
① ② ③	<p>When devices that handle low-level signals and are liable to malfunction due to noises, e.g. instruments, receivers and sensors, are contained in the enclosure that contains the inverter or when their signal cables are run near the inverter, the devices may be malfunctioned by air-propagated noises. The following measures must be taken:</p> <ul style="list-style-type: none"> <li>• Install easily affected devices as far away as possible from the inverter.</li> <li>• Run easily affected signal cables as far away as possible from the inverter and its I/O cables.</li> <li>• Do not run the signal cables and power cables (inverter I/O cables) in parallel with each other and do not bundle them.</li> <li>• Use the inverter with the ON/OFF connector of the EMC filter set to ON. (Refer to section 3.9.3.)</li> <li>• Inserting a filter (dU/dt, sine wave filter) into the output suppresses the radiation noise from the cables.</li> <li>• Use shield cables as signal cables and power cables and run them in individual metal conduits to produce further effects.</li> </ul>
④ ⑤ ⑥	<p>When the signal cables are run in parallel with or bundled with the power cables, magnetic and static induction noises may be propagated to the signal cables to malfunction the devices and the following measures must be taken:</p> <ul style="list-style-type: none"> <li>• Install easily affected devices as far away as possible from the inverter.</li> <li>• Run easily affected signal cables as far away as possible from the I/O cables of the inverter.</li> <li>• Do not run the signal cables and power cables (inverter I/O cables) in parallel with each other and do not bundle them.</li> <li>• Use shield cables as signal cables and power cables and run them in individual metal conduits to produce further effects.</li> </ul>
⑦	<p>When the power supplies of the peripheral devices are connected to the power supply of the inverter in the same line, inverter-generated noises may flow back through the power supply cables to malfunction the devices and the following measures must be taken:</p> <ul style="list-style-type: none"> <li>• Use the inverter with the ON/OFF connector of the EMC filter set to ON. (Refer to section 3.9.3.)</li> <li>• Use additional (optional) noise filters as required.</li> <li>• Install output filters to the power cables of the inverter after you consulted MITSUBISHI.</li> </ul>
⑧	<p>When a closed loop circuit is formed by connecting the peripheral device wiring to the inverter, leakage currents may flow through the earth cable of the inverter to malfunction the device. In such a case, disconnection of the earth cable of the device may cause the device to operate properly.</p>

Tab. 3-28: Noise and Countermeasures

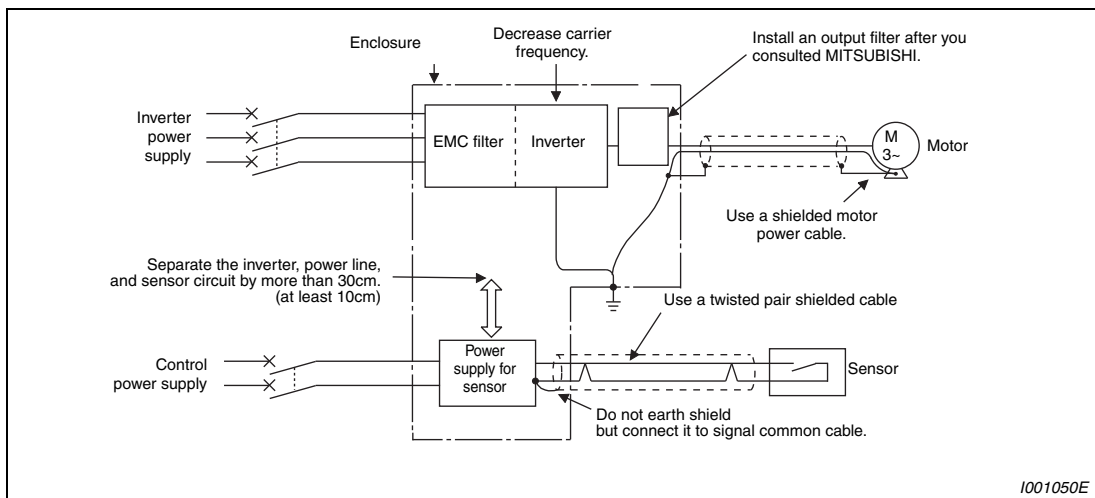
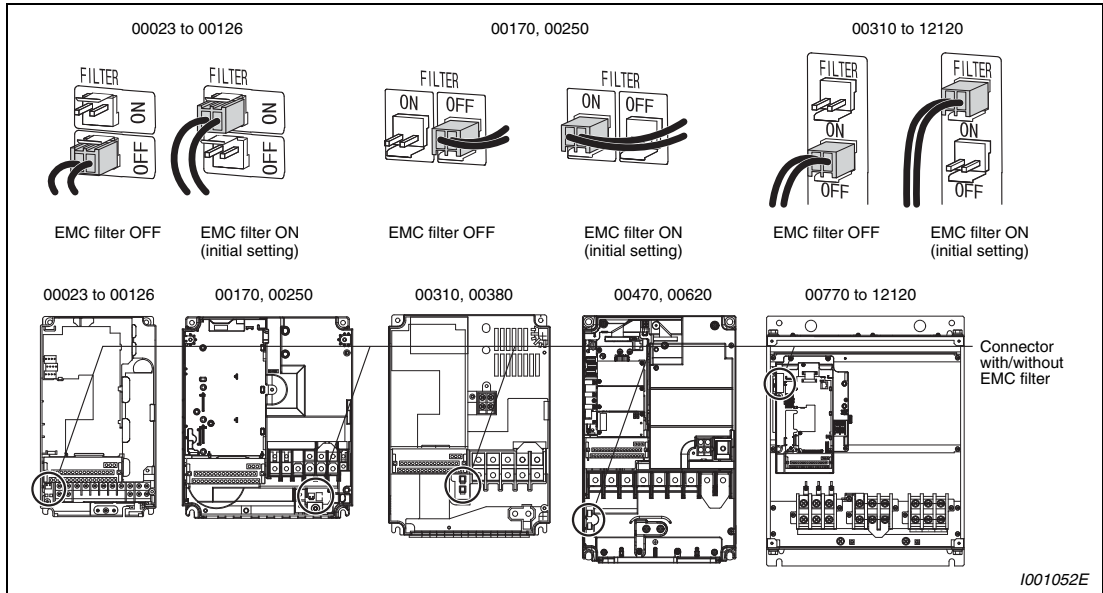

Fig. 3-49: Noise reduction examples

### 3.9.3 EMC filter

The inverter is equipped with a built-in EMC filter and zero-phase reactor. Effective for reduction of air-propagated noise on the input side of the inverter. The EMC filter is factory-set to enable (ON). To disable it, fit the EMC filter ON/OFF connector to the OFF position. The filter must be deactivated when the inverter is used in networks with an isolated neutral (IT networks). The input side zero-phase reactor, built-in the 01800 or less inverter, is always valid regardless of on/off of the EMC filter on/off connector.



**Fig. 3-50: Built-in EMC filter**

#### How to disconnect the connector

- ① After confirming that the power supply is off, remove the front cover. (For the front cover removal method, refer to section 2.2).
- ② When disconnecting the connector, push the fixing tab and pull the connector straight without pulling the cable or forcibly pulling the connector with the tab fixed. When installing the connector, also engage the fixing tab securely. If it is difficult to disconnect the connector, use a pair of long-nose pliers, etc.

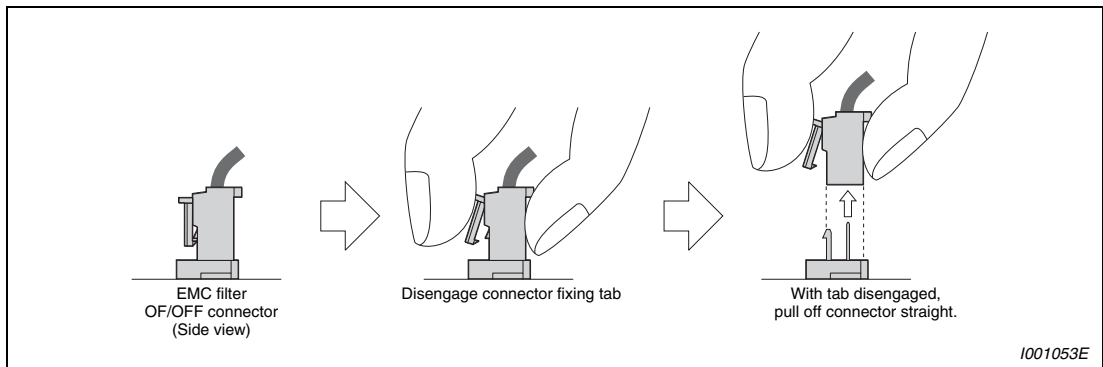

**Fig. 3-51: Activating the built-in EMC filter**

**NOTE** | Fit the connector to either ON or OFF.



**WARNING:**  
**While power is on or when the inverter is running, do not open the front cover. Otherwise you may get an electric shock.**

### 3.9.4 Power supply harmonics

The inverter may generate power supply harmonics from its converter circuit to affect the power generator, power capacitor etc. Power supply harmonics are different from noise and leakage currents in source, frequency band and transmission path. Take the following countermeasure suppression techniques.

Item	Harmonics	Noise
Frequency	Maximum 50 ( $\leq 3\text{kHz}$ )	Several 10kHz to 1GHz
Environment	To electric channel, power impedance	To-space, distance, wiring path
Quantitative understanding	Theoretical calculation possible	Random occurrence, quantitative grasping difficult
Generated amount	Nearly proportional to load capacity	Depending on the current fluctuation ratio (larger as switching is faster)
Affected equipment immunity	Specified in standard per equipment	Different depending on maker's equipment specifications
Suppression example	Provide reactor	Increase distance

**Tab. 3-29:** Differences between harmonics and noises

● Measures

The harmonic current generated from the inverter to the input side differs according to various conditions such as the wiring impedance, whether a reactor is used or not, and output frequency and output current on the load side.

For the output frequency and output current, we understand that they should be calculated in the conditions under the rated load at the maximum operating frequency.

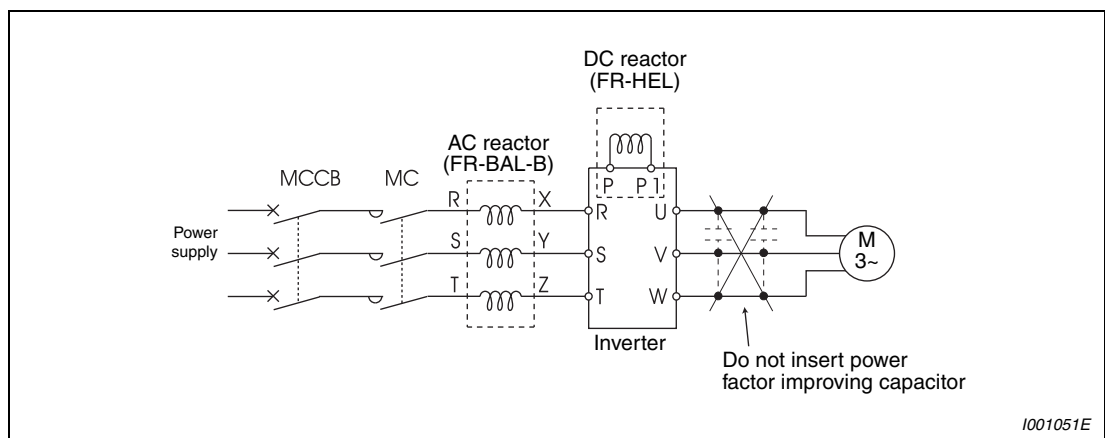

**Fig. 3-52:** Reduction of power supply harmonics



**CAUTION:**

*The power factor improving capacitor and surge suppressor on the inverter output side may be overheated or damaged by the harmonic components of the inverter output. Also, since an excessive current flows in the inverter to activate over current protection, do not provide a capacitor and surge suppressor on the inverter output side when the motor is driven by the inverter. For power factor improvement, install a reactor on the inverter input side or in the DC circuit.*

### 3.9.5 Inverter-driven 400V class motor

In the PWM type inverter, a surge voltage attributable to wiring constants is generated at the motor terminals. Especially for a 400V class motor, the surge voltage may deteriorate the insulation. When the 400V class motor is driven by the inverter, consider the following measures:

- Rectifying the motor insulation and limiting the PWM carrier frequency according to the wiring length. For the 400V class motor, use an insulation-enhanced motor.
  - Specify the "400V class inverter-driven insulation-enhanced motor".
  - For the dedicated motor such as the constant-torque motor and low-vibration motor, use the "inverter-driven, dedicated motor".
  - Set Pr. 72 "PWM frequency selection" as indicated below according to the wiring length.

	Wiring Length		
	≤ 50m	50m to 100m	≥ 100m
Parameter 72	≤ 15 (14.5kHz)	≤ 9 (9kHz)	≤ 4 (4kHz)

**Tab. 3-30:** Setting of Pr. 72 according to the wiring length

- Limiting the voltage rise speed of the frequency inverter output voltage (dU/dT):  
If the motor requires a rise speed of 500V/μs or less you must install a filter in the output of the inverter. Please contact your Mitsubishi dealer for more details.

#### NOTES

For details of Pr. 72 "PWM frequency selection", refer to section 6.19.

When using an option sine wave filter (MT-BSL/BSC) for the 02160 or more, set "25" (2.5kHz) in Pr. 72.

Do not perform vector control with a surge voltage suppression filter (FR-ASF-H) or sine wave filter (MT-BSL/BSC) connected.

# 4 Operation

## 4.1 Precautions for use of the inverter

The FR-A700 series is a highly reliable product, but incorrect peripheral circuit making or operation/handling method may shorten the product life or damage the product.

Before starting operation, always recheck the following items.

- Use crimping terminals with insulation sleeve to wire the power supply and motor.
- Application of power to the output terminals (U, V, W) of the inverter will damage the inverter. Never perform such wiring.
- After wiring, wire offcuts must not be left in the inverter. Wire offcuts can cause an alarm, failure or malfunction. Always keep the inverter clean. When drilling mounting holes in a control box etc., take care not to allow chips and other foreign matter to enter the inverter.
- Use cables of the size to make a voltage drop 2% maximum. If the wiring distance is long between the inverter and motor, a main circuit cable voltage drop will cause the motor torque to decrease especially at the output of a low frequency. (Refer to page 3-12 for the recommended cable sizes.)
- The overall wiring length should be 500m maximum. (The wiring length should be 30m maximum for vector control.) Especially for long distance wiring, the fast-response current limit function may be reduced or the equipment connected to the inverter output side may malfunction or become faulty under the influence of a charging current due to the stray capacity of the wiring. Therefore, note the overall wiring length. (Refer to page 3-15.)
- Electromagnetic Compatibility  
Operation of the frequency inverter can cause electromagnetic interference in the input and output that can be propagated by cable (via the power input lines), by wireless radiation to nearby equipment (e.g. AM radios) or via data and signal lines. Activate the integrated EMC filter (and an additional optional filter if present) to reduce air propagated interference on the input side of the inverter. Use AC or DC reactors to reduce line propagated noise (harmonics). Use shielded motor power lines to reduce output noise (refer also to section 3.8 Electromagnetic Compatibility).
- Do not install a power factor correction capacitor, surge suppressor or radio noise filter on the inverter output side. This will cause the inverter to trip or the capacitor and surge suppressor to be damaged. If any of the above devices is installed, immediately remove it.
- Before starting wiring or other work after the inverter is operated, wait for at least 10 minutes after the power supply has been switched off, and check that there are no residual voltage using a tester or the like. The capacitor is charged with high voltage for some time after power off and it is dangerous.

- A short circuit or earth fault on the inverter output side may damage the inverter modules.
  - Fully check the insulation resistance of the circuit prior to inverter operation since repeated short circuits caused by peripheral circuit inadequacy or an earth fault caused by wiring inadequacy or reduced motor insulation resistance may damage the inverter modules.
  - Fully check the to-earth insulation and inter-phase insulation of the inverter output side before power-on.  
Especially for an old motor or use in hostile atmosphere, securely check the motor insulation resistance etc.
- Do not use the inverter input side magnetic contactor to start/stop the inverter. Always use the start signal (ON/OFF of STF and STR signals) to start/stop the inverter.
- Across P/+ and PR terminals, connect only an external regenerative brake discharge resistor. Do not connect a mechanical brake.
- Do not apply a voltage higher than the permissible voltage to the inverter I/O signal circuits. Contact to the inverter I/O signal circuits or opposite polarity may damage the I/O devices. Especially check the wiring to prevent the speed setting potentiometer from being connected incorrectly to short terminals 10E (10, respectively) -5.
- Provide electrical and mechanical interlocks for MC1 and MC2 which are used for commercial power supply-inverterswitch-over.  
When the wiring is incorrect or if there is a commercial power supply-inverter switch-over circuit as shown below, the inverter will be damaged by leakage current from the power supply due to arcs generated at the time of switch-over or chattering caused by a sequence error.  
(Commercial operation can not be performed with the vector dedicated motor (SF-V5RU, SF-THY).)

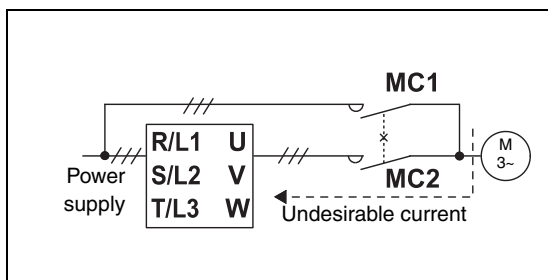

**Fig. 4-1:**  
Mechanical interlocks for MC1 and MC2

I001042E



**CAUTION:**

***If the machine must not be restarted when power is restored after a power failure, provide a magnetic contactor in the inverter's input side and also make up a sequence which will not switch on the start signal.***

***If the start signal (start switch) remains on after a power failure, the inverter will automatically restart as soon as the power is restored.***

- Instructions for overload operation  
When performing operation of frequent start/stop of the inverter, increase/decrease in the temperature of the transistor element of the inverter may repeat due to a continuous flow of large current, shortening the life from thermal fatigue. Since thermal fatigue is related to the amount of current, the life can be increased by reducing bound current, starting current, etc. Decreasing current may increase the life. However, decreasing current will result in insufficient torque and the inverter may not start. Therefore, increase the inverter capacity to have enough allowance for current.
- Make sure that the specifications and rating match the system requirements.
- A motor with encoder is necessary for vector control. In addition, connect the encoder directly to the backlash-free motor shaft. (An encoder is not necessary for real sensorless vector control.)

## 4.2 Drive the motor

The inverter needs frequency command and start command. Turning the start command on start the motor rotating and the motor speed is determined by the frequency command (set frequency). Refer to the flow chart below to perform setting.

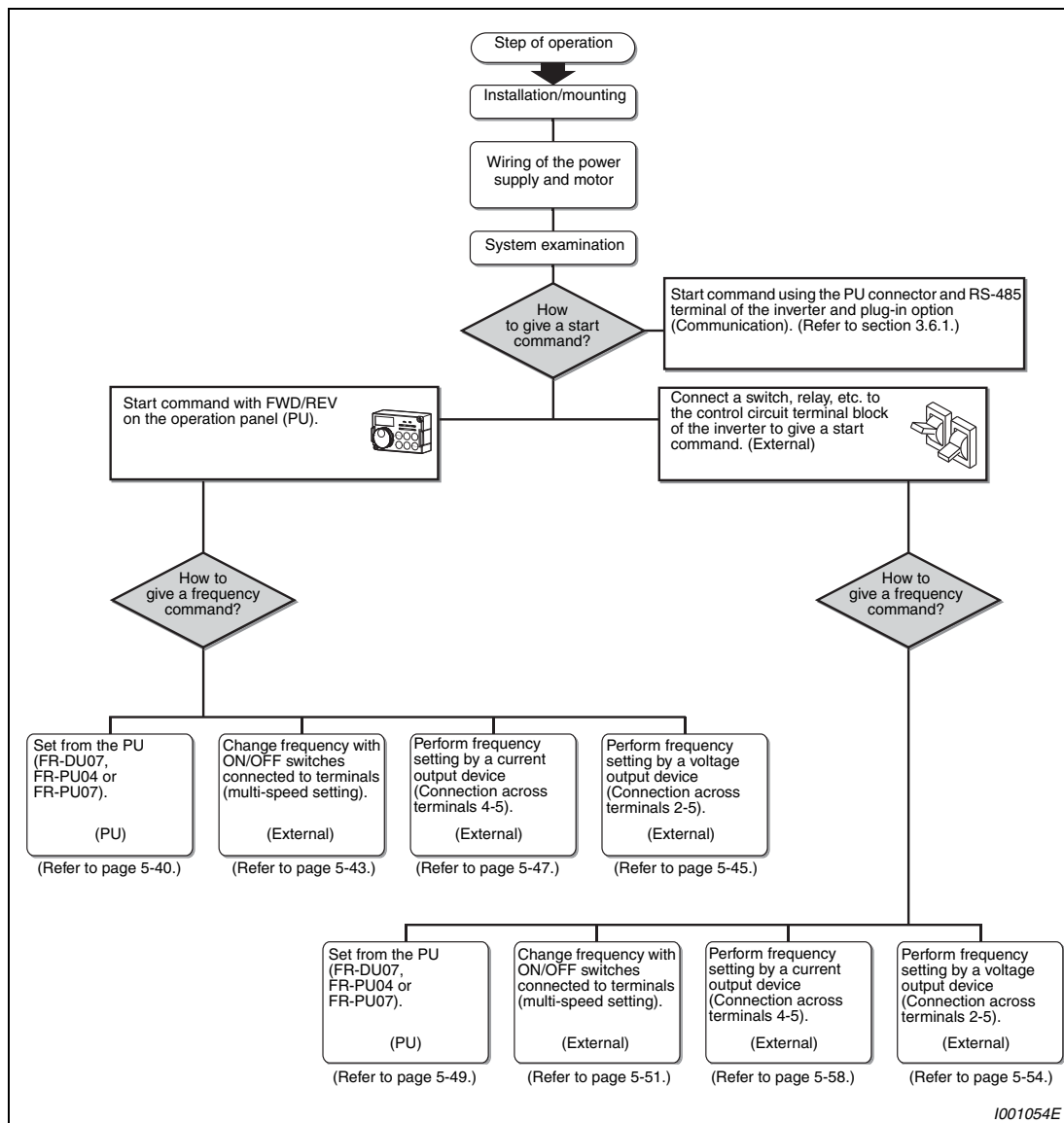

**Fig. 4-2: Steps of operation**

Check the following items before powering on the inverter:

- Check that the inverter is installed correctly in a correct place. (Refer to section 2.3.)
- Check that wiring is correct. (Refer to section 3.2.)
- Check that no load is connected to the motor.

### NOTES

When protecting the motor from overheat by the inverter, set Pr. 9 "Electronic thermal O/L relay". (Refer to section 5.1.1.)

When the rated frequency of the motor is not 50Hz, set Pr. 3 "Base frequency" (Refer to section 5.1.2.)





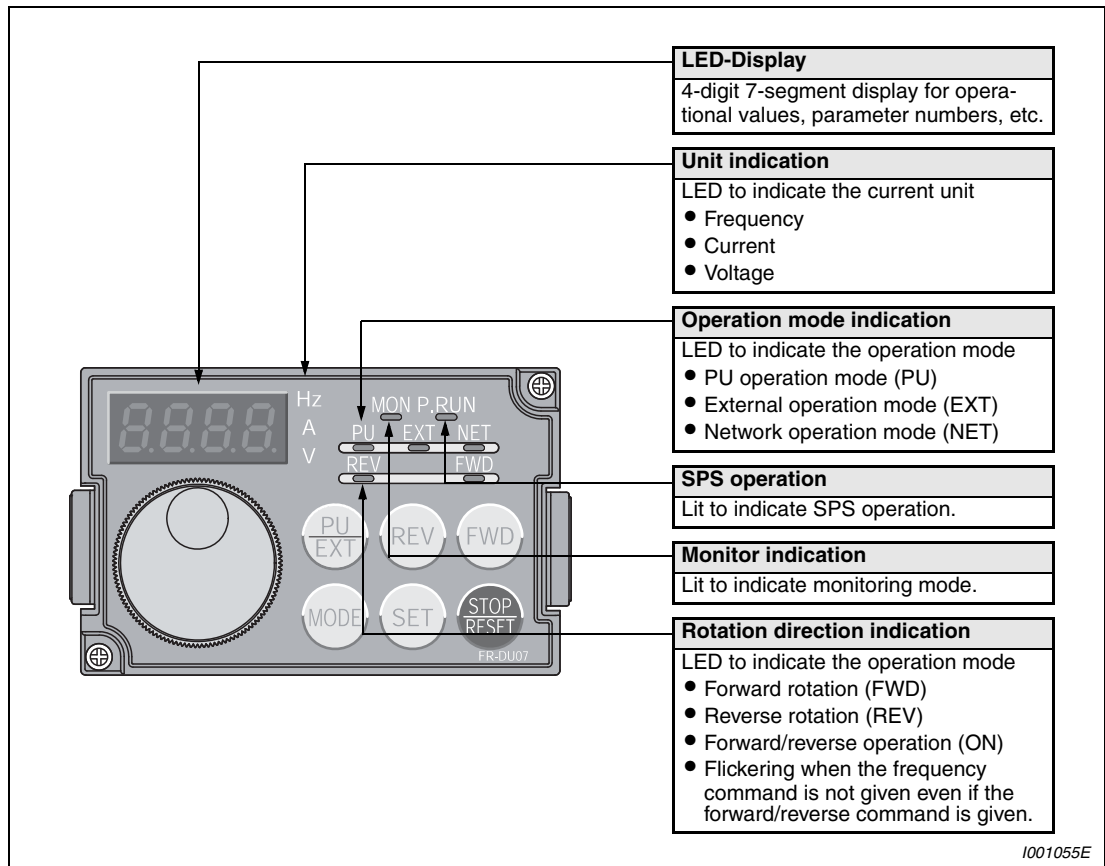

## 4.3 Operation panel FR-DU07

### 4.3.1 Parts of the operation panel

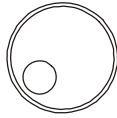

**Fig. 4-3:** Parts of the operation panel FR-DU07



Key	Function	Description
	Digital dial	Used to change the frequency setting and parameter values. Push the setting dial to display the set frequency currently set.
	Rotation direction	Start command forward rotation
	Rotation direction	Start command reverse rotation
	Stop operation/Alarm reset	Alarms can be reset. (Malfunctions of the inverter can be acknowledged.)
	Write settings	<p>If pressed during operation, monitor changes as below:</p> <pre> graph LR     A[Running frequency] --&gt; B[Output current]     B --&gt; C[Output voltage ①]     C --&gt; A                     </pre> <p>① Energy saving monitor is displayed when the energy saving monitor of Pr. 52 is set.</p>
	Mode switch over	Use to change the setting mode.
	Operation mode switch over	Used to switch between the PU and external operation mode. When using the external operation mode (operation using a separately connected frequency setting potentiometer and start signal), press this key to light up the EXT indication. (Change the Pr. 79 value to use the combined mode.) PU: PU operation mode EXT: External operation mode

**Tab. 4-1:** Keys of the operation panel

### 4.3.2 Basic operation (factory setting)

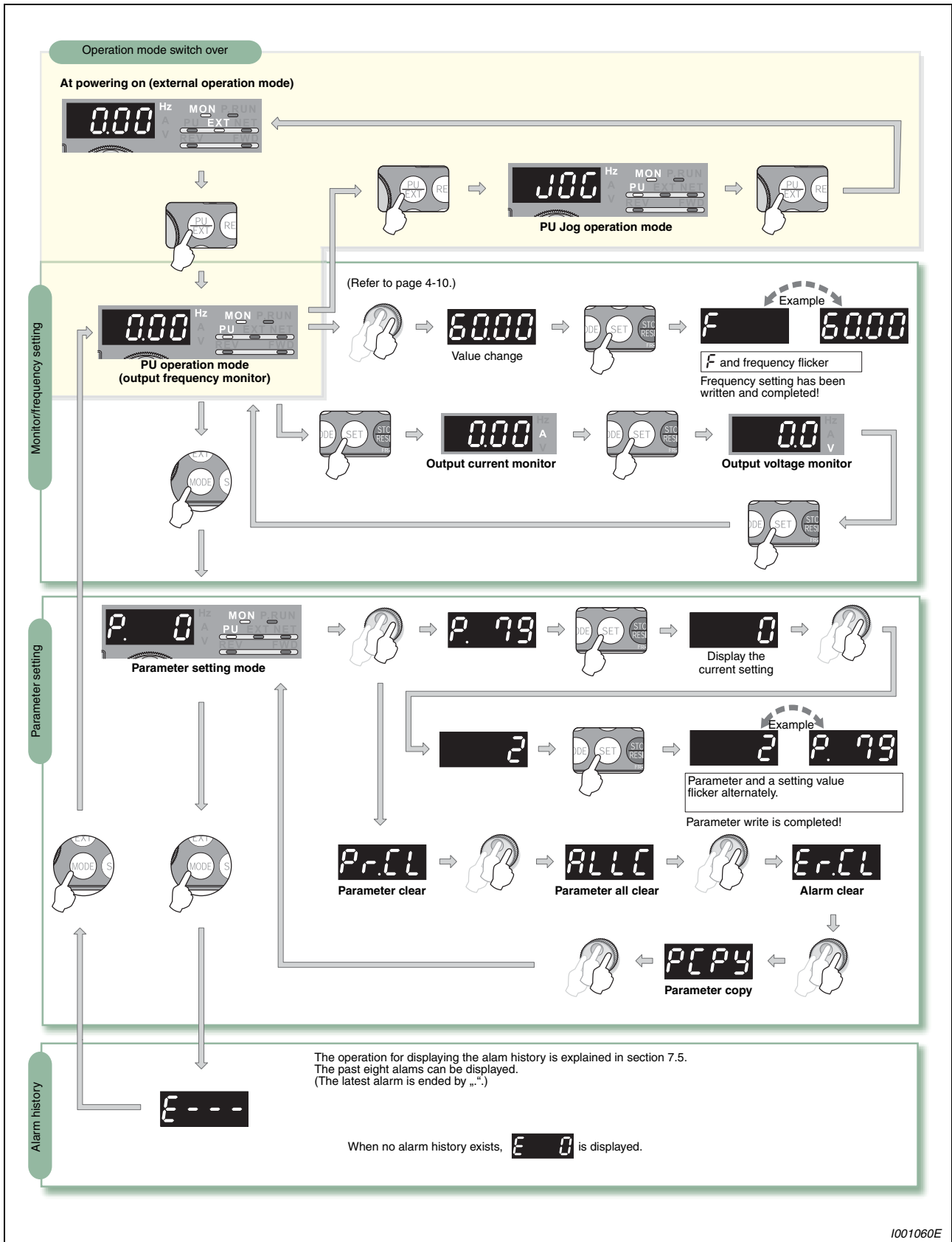

Fig. 4-4: Overview of the basic functions of the operation panel FR-DU07

### 4.3.3 Operation lock

Operation using the digital dial and key of the operation panel can be made invalid to prevent parameter change and unexpected start and stop.

Operation procedure:

- ① Set „10“ or „11“ in Pr. 161, then press the MODE key for 2s to make the digital dial key operation invalid.
- ② When the digital dial and key operation is made invalid, "HOLD" appears on the operation panel.
- ③ When the digital dial and key operation is invalid, "HOLD" appears if the digital dial or key operation is performed. (When the digital dial or key operation is not performed for 2s, the monitor display appears.)
- ④ To make the digital dial and key operation valid again, press the MODE key for 2s.

**NOTE**

Set "10 or 11" (key lock mode valid) in Pr. 161 "Frequency setting/key lock operation selection".

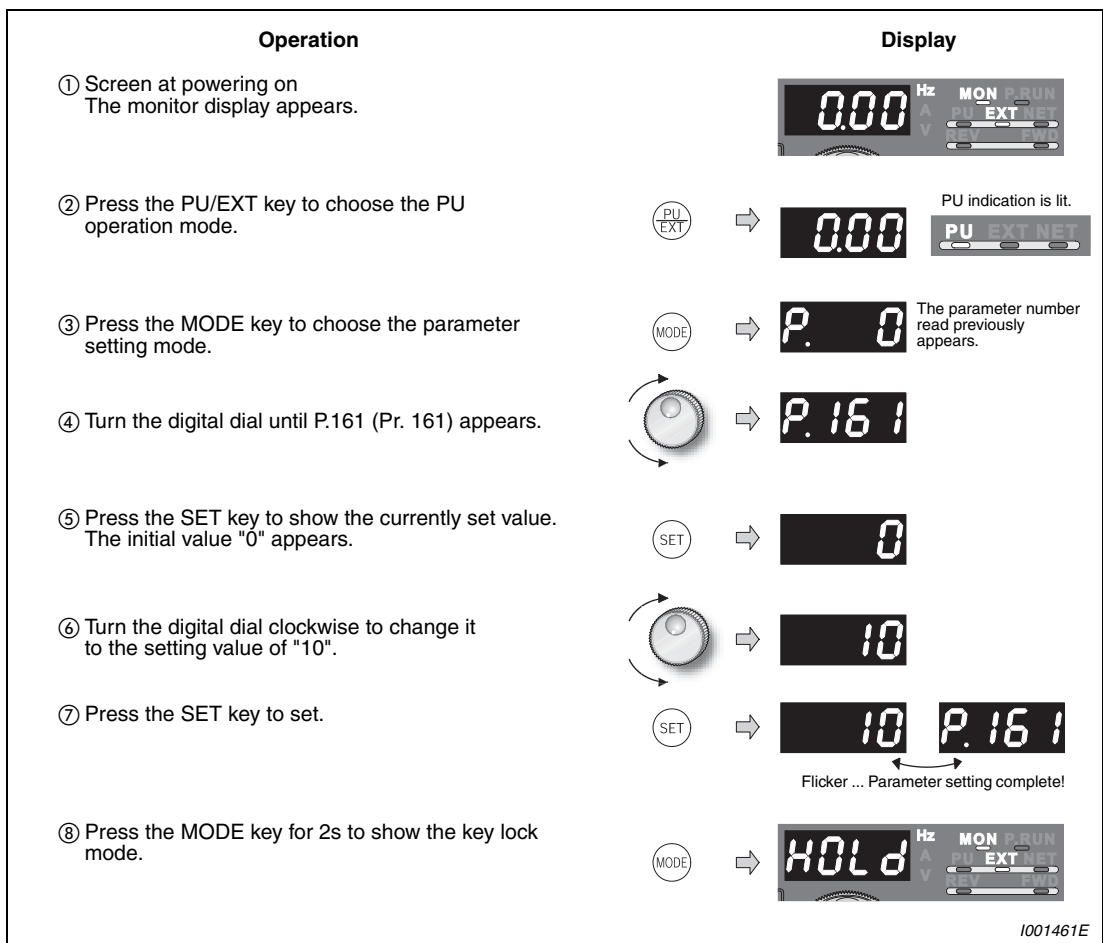

Fig. 4-5: Operation lock

**NOTE**

The STOP/RESET key is valid even in the operation lock status.

### 4.3.4 Monitoring of output current and output voltage

Monitor display of output frequency, output current and output voltage can be changed by pushing the SET key during monitoring mode.

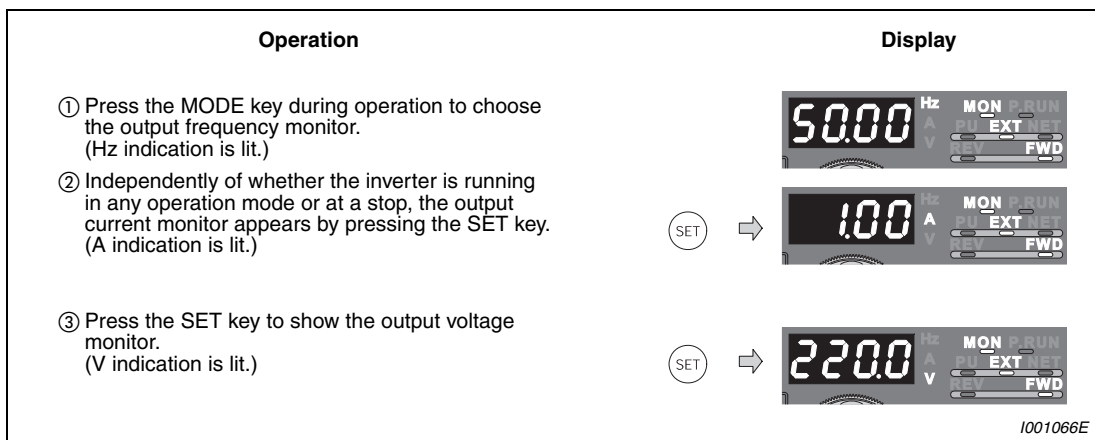

**Fig. 4-6:** Monitoring of output current and output voltage

### 4.3.5 First priority monitor

Hold down the SET key for 1s to set monitor description to be appeared first in the monitor mode.  
(To return to the output frequency monitor, hold down the SET key for 1s after displaying the output frequency monitor.)

### 4.3.6 Digital dial push

Push the digital dial to display the set frequency currently set.

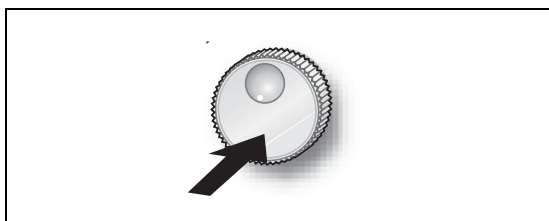
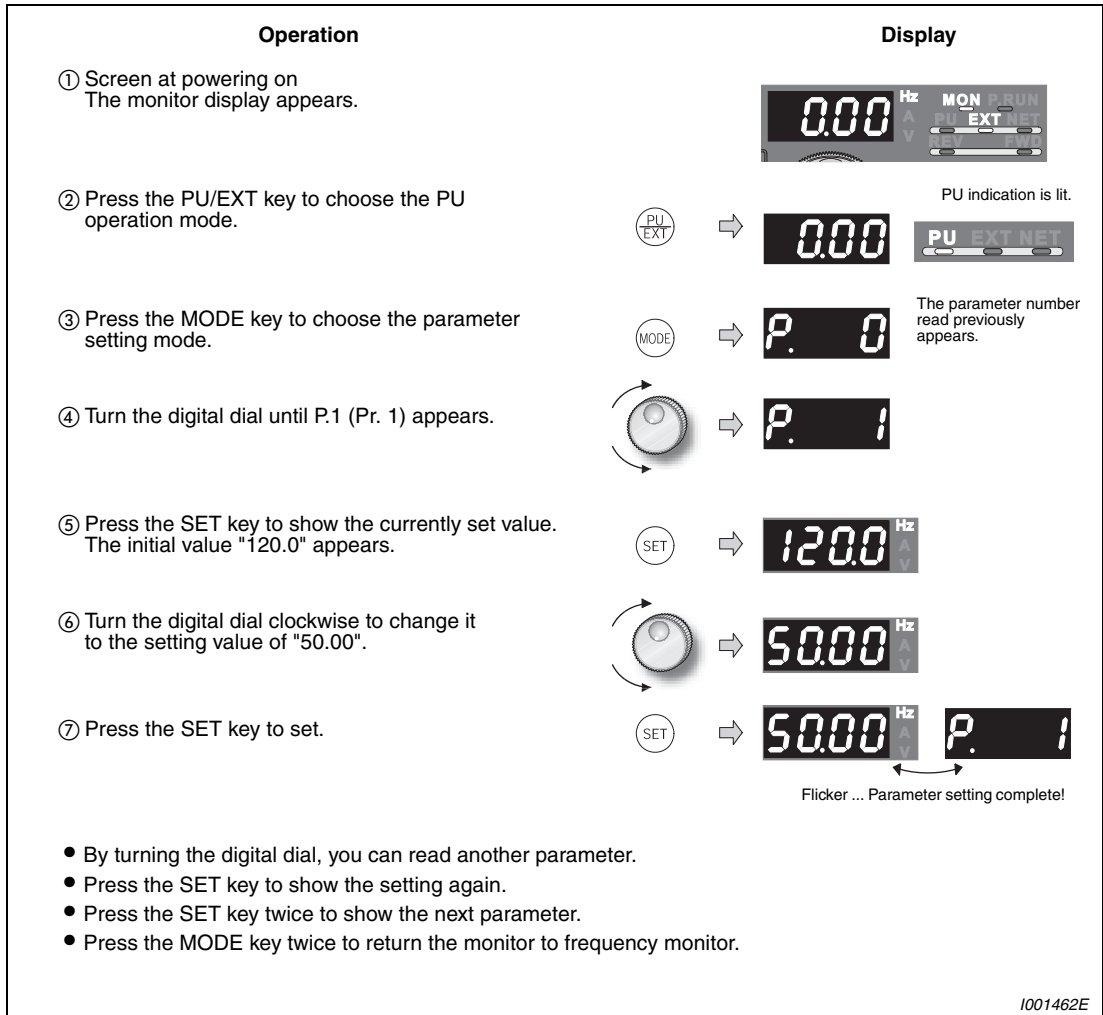

**Fig. 4-7:**  
Display the set frequency currently set

1001067E

### 4.3.7 Change the parameter setting value

**Example** ▾ Change the Pr. 1 "Maximum frequency".



**Fig. 4-8:** Setting the maximum frequency

### 4.3.8 Parameter clear

- Set "1" in Pr.CL "Parameter clear" to initialize all parameters. (Parameters are not cleared when "1" is set in Pr. 77 "Parameter write selection". In addition, calibration parameters are not cleared.)
- Refer to Tab. 6-1 for parameters to be cleared with this operation.

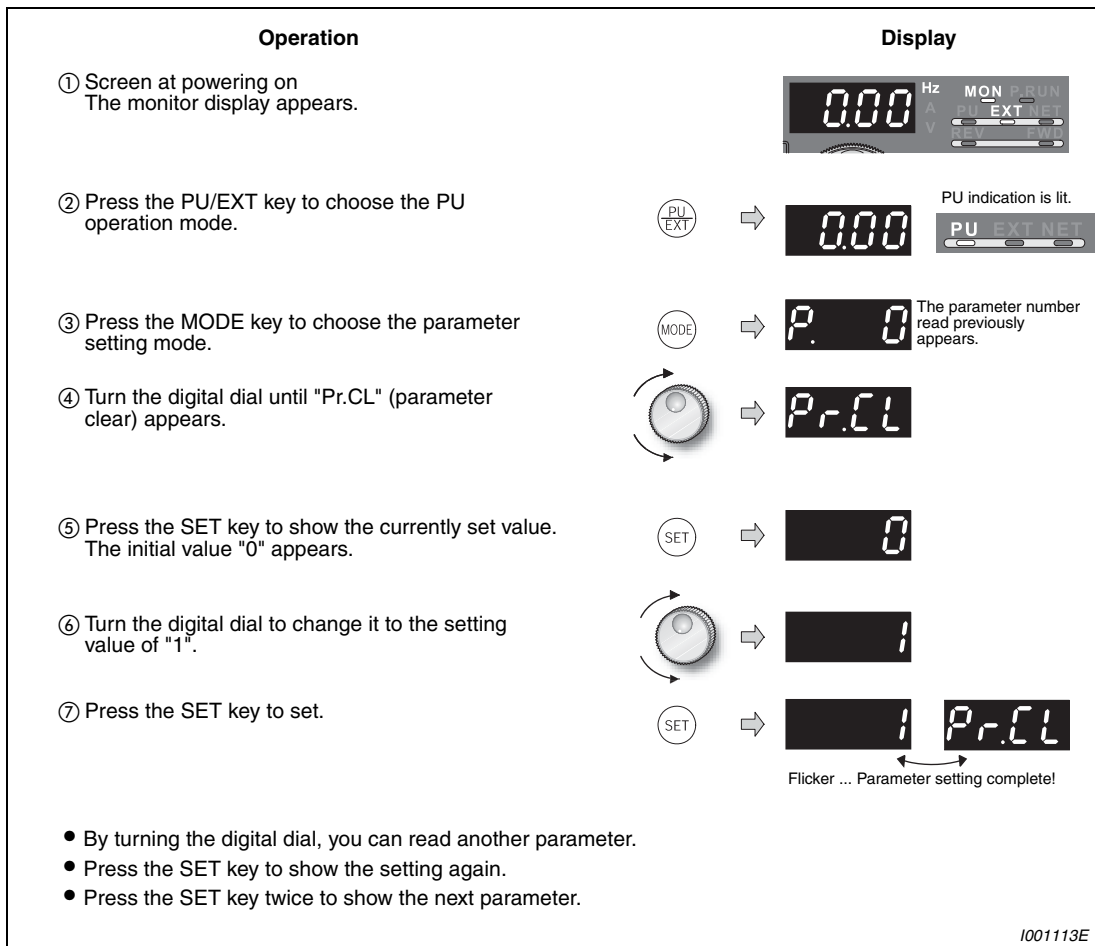

**Fig. 4-9:** Parameter clear

**Possible faults:**

- "1" and "Er4" are displayed alternately.
  - The inverter is not in the PU operation mode. Press the PU/EXT key. The PU indication is lit. Carry out operation from step ⑥ again.

### 4.3.9 All parameter clear

- Set "1" in ALLC "All parameter clear" to initialize all parameters. (Parameters are not cleared when "1" is set in Pr. 77 "Parameter write selection". In addition, calibration parameters are not cleared.)
- Refer to Tab. 6-1 for parameters to be cleared with this operation.

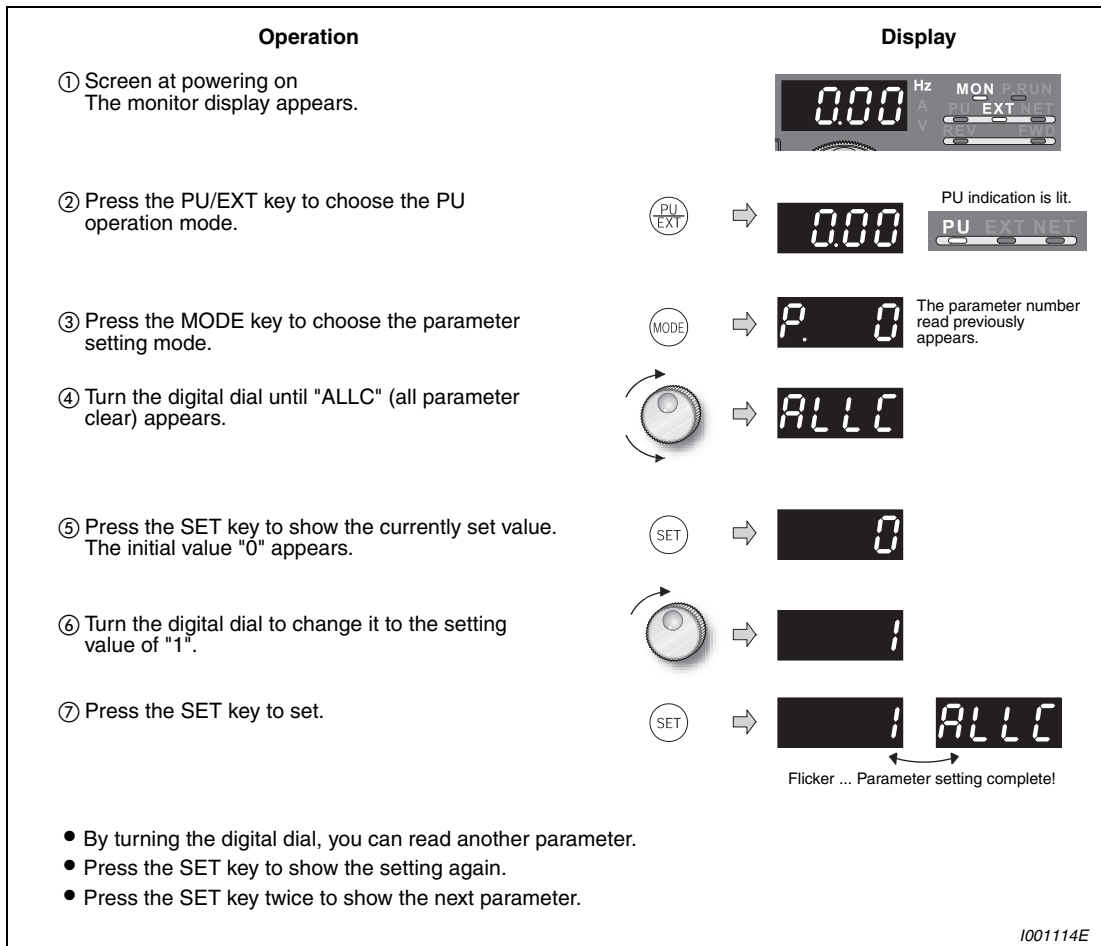

**Fig. 4-10:** All parameter clear

**Possible faults:**

- "1" and "Er4" are displayed alternately.
  - The inverter is not in the PU operation mode. Press the PU/EXT key. The PU indication is lit. Carry out operation from step ⑥ again.



### 4.3.10 Parameter copy an parameter verification

PCPY Setting	Description
0	Cancel
1	Copy the source parameters to the operation panel.
2	Write the parameters copied to the operation panel into the destination inverter.
3	Verify parameters in the inverter and operation panel.

**Tab. 4-2:** *Setting of parameter PCPY*

#### NOTES

When the copy destination inverter is not the FR-A700 series or parameter copy write is performed after parameter read is stopped, "model error (rE4)" is displayed.

Refer to the extended parameter list Tab. 6-1 for availability of parameter copy.

When the power is turned off or an operation panel is disconnected, etc. during parameter copy write, perform write again or check the values by parameter verification.

### 4.3.11 Parameter copy

Multiple inverters and parameter settings can be copied.

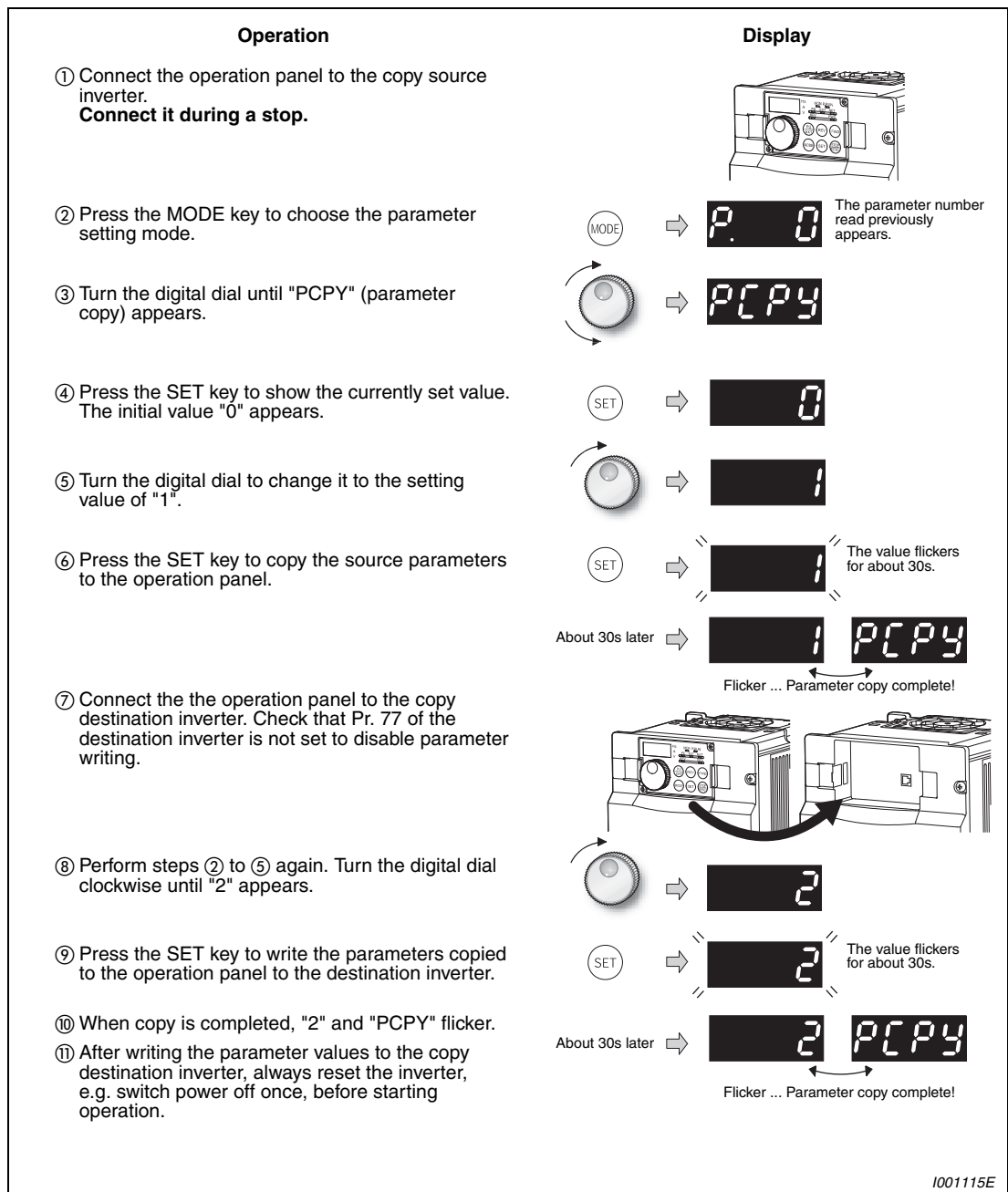

**Fig. 4-11: Parameter copy**

**Possible faults:**

- "rE1" appears.
  - A parameter read error has occurred. Perform operation in Fig. 4-11 from step ③ again.
- "rE2" appears.
  - A parameter write error has occurred. Perform operation in Fig. 4-11 from step ⑧ again.
- "rE4" appears.
  - The copy destination inverter is no FR-A700 model or the parameter write disable function is activated in parameter 77. Set "0" in Pr. 160 "User group read selection" and set Pr. 77 "Parameter write selection" to "0" or "2".
- "CP" and "0.00" appear alternately.
  - Appears when parameters are copied between the inverter of 01800 or less and 02160 or more.

Countermeasure:









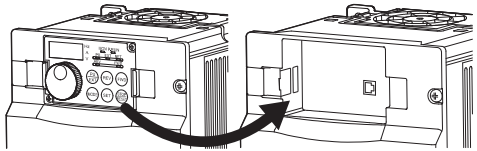

- ① Set "0" in Pr. 160 "User group read selection".
- ② Set the following setting (initial value) in Pr. 989 Parameter copy alarm release.

	01800 or less	02160 or more
Pr. 989 setting	10	100

- ③ Reset Pr. 9, Pr. 30, Pr. 51, Pr. 52, Pr. 54, Pr. 56, Pr. 57, Pr. 61, Pr. 70, Pr. 72, Pr. 80, Pr. 82, Pr. 90 to Pr. 94, Pr. 158, Pr. 455, Pr. 458 to Pr. 463, Pr. 557, Pr. 859, Pr. 860, Pr. 893.

### 4.3.12 Parameter verification

Whether same parameter values are set in other inverters or not can be checked.

Operation	Display
① Replace the operation panel on the inverter to be verified <b>Replace it during a stop.</b>	
② Screen at powering on The monitor display appears.	
③ Press the MODE key to choose the parameter setting mode.	 The parameter number read previously appears.
④ Turn the digital dial until "PCPY" (parameter copy) appears.	
⑤ Press the SET key to show the currently set value. The initial value "0" appears.	
⑥ Turn the digital dial to change it to the setting value of "3" (parameter copy verification mode).	
⑦ Press the SET key to read the parameter setting of the verified inverter to the operation panel.	 The value flickers for about 30s.
<ul style="list-style-type: none"> <li>• If different parameter exist, different parameter numbers and "rE3" flicker.</li> </ul>	
<ul style="list-style-type: none"> <li>• Hold down the SET key to verify.</li> </ul>	 Flickering
⑧ If there is no difference, "PCPY" and "3" flicker to complete verification.	 Flicker ... Parameter verification complete!

I001116E

**Fig. 4-12: Parameter verification**

**Possible faults:**

- "rE3" appears.
  - Set frequencies, etc. may be different. Check set frequencies.

**NOTE**

When the copy destination inverter is not the FR-A700 series, "model error rE4" is displayed.

# 5 Basic settings

## 5.1 Simple mode parameter list

For simple variable-speed operation of the inverter, the initial setting of the parameters may be used as they are. Set the necessary parameters to meet the load and operational specifications. Parameter setting, change and check can be made from the operation panel (FR-DU07). For details of parameters, refer to chapter 6.

**NOTE**

Simple mode and extended mode parameters are displayed by the initial setting of Pr. 160 "User group read selection". Set Pr. 160 "User group read selection" as required. (Refer to section 6.21.4.)

Pr. 160	Description
9999	Only the simple mode parameters can be displayed.
0 (Initial value)	Simple mode and extended mode parameters can be displayed.
1	Only parameters registered in the user group can be displayed.

**Tab. 5-1:** Setting of parameter 160

Pr.	Name	Increments	Initial Value	Range	Description	Refer to
0	Torque boost	0.1%	6/4/3/2/1 <sup>①</sup>	0–30%	Set to increase a starting torque or when the motor with a load will not rotate, resulting in an alarm (OL) and a trip (OC1). <sup>①</sup> Initial values differ according to the inverter capacity. (00023, 00038/00052 to 00126/00170, 00250/00310 to 01800/021600 or more)	5-6
1	Maximum frequency	0.01Hz	120/ 60Hz <sup>②</sup>	0–120Hz	Set when the maximum output frequency need to be limited. <sup>②</sup> Initial values differ according to the inverter capacity. (01800 or less/02160 or more)	5-8
2	Minimum frequency	0.01Hz	0Hz	0–120Hz	Set when the minimum output frequency need to be limited.	
3	Base frequency	0.01Hz	50Hz	0–400Hz	Check the motor rating plate.	5-5
4	Multi-speed setting (high speed)	0.01Hz	50Hz	0–400Hz	Set when changing the preset speed in the parameter with a terminal.	5-51
5	Multi-speed setting (middle speed)	0.01Hz	30Hz	0–400Hz		
6	Multi-speed setting (low speed)	0.01Hz	10Hz	0–400Hz		

**Tab. 5-2:** Simple mode parameters (1)

Pr.	Name	Increments	Initial value	Range	Description	Refer to
7	Acceleration time	0.1s	5/15s <sup>③</sup>	0–3600s	Acceleration/deceleration time can be set. <sup>③</sup> Initial values differ according to the inverter capacity. (00250 or less/00310 or more)	5-10
8	Deceleration time	0.1s	10/30s <sup>③</sup>	0–3600s		
9	Electronic thermal O/L relay	0.01/ 0.1A <sup>④</sup>	Rated inverter output current	0–500/ 0–3600A <sup>④</sup>	Protect the motor from overheat by the inverter. Set the rated motor current. <sup>④</sup> The increments and setting range differ according to the inverter capacity. (01800 or less/02160 or more)	5-3
79	Operation mode selection	1	0	0/1/2/3/4/6/7	Select the start command location and frequency command location.	5-12
125	Terminal 2 frequency setting gain frequency	0.01Hz	50Hz	0–400Hz	Frequency for the maximum value of the potentiometer (5V initial value) can be changed.	5-57
126	Terminal 4 frequency setting gain frequency	0.01Hz	50Hz	0–400Hz	Frequency for the maximum current input (20mA initial value) can be changed.	5-60
160	User group read selection	1	9999	0/1/9999	Make extended parameters valid	6-412

**Tab. 5-2:** Simple mode parameters (2)

### 5.1.1 Overheat protection of the motor by the inverter

Set this parameter when using a motor other than the Mitsubishi standard motor (SF-JR) and Mitsubishi constant-torque motor (SF-HRCA). Set the rated motor current in Pr. 9 "Electronic thermal O/L relay" to protect the motor from overheat.

Pr. No.	Name	Initial Value	Setting Range ②		Description
9	Electronic thermal O/L relay	Rated inverter output current ①	01800 or less	0-500A	Set the rated motor current.
			02160 or more	0-3600A	

① Refer to appendix A for the rated inverter current value. The initial values of the 00023 and 00038 are set to 85% of the rated inverter current.

② The minimum setting increments are 0.01A for the 01800 or less and 0.1A for the 02160 or more.

**Example** ▾

Change the Pr. 9 "Electronic thermal O/L relay" setting to 2.5A (FR-A740-00023-EC) according to the motor rated current.

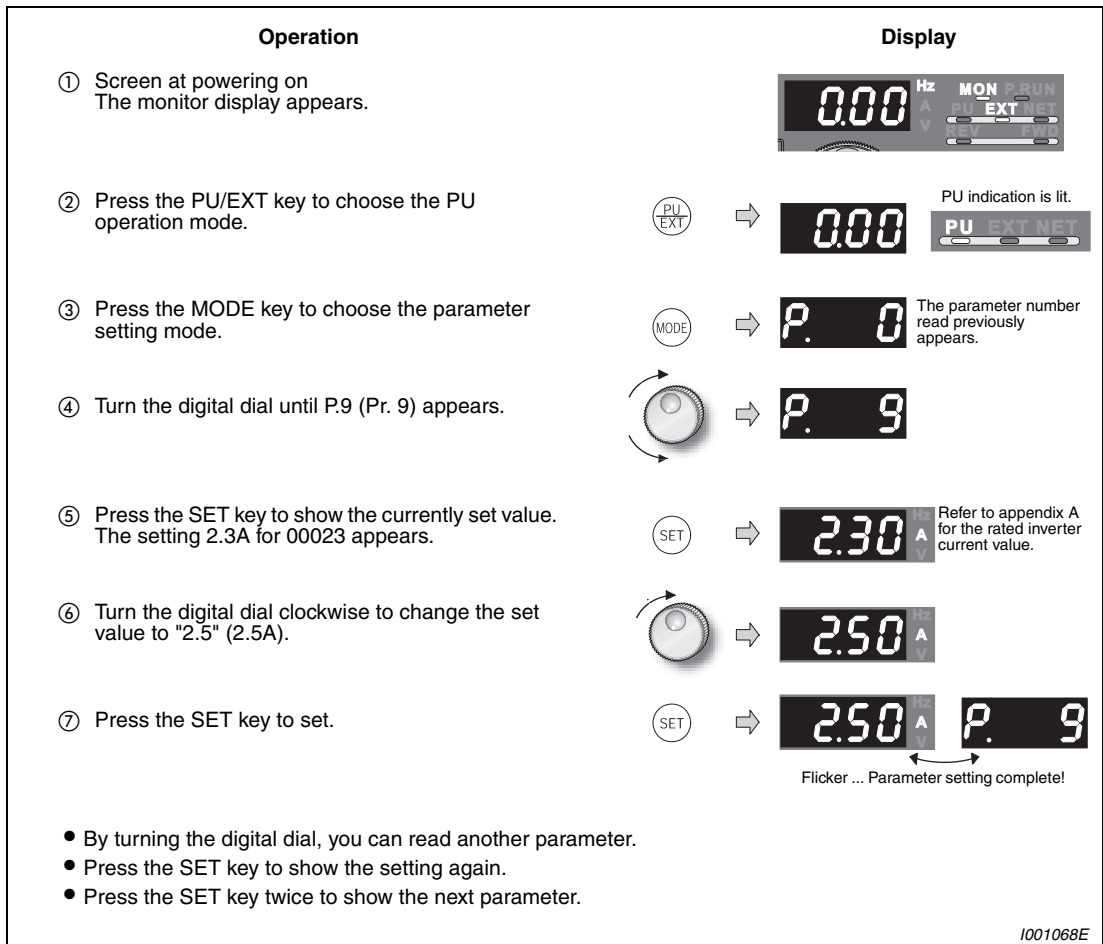

**Fig. 4-1:** Setting of the electronic thermal O/L relay



**NOTES**

Protective function by electronic thermal relay function is reset by inverter power reset and reset signal input. Avoid unnecessary reset and power-off.

When two or more motors are connected to the inverter, they cannot be protected by the electronic thermal relay function. Install an external thermal relay to each motor.

When the difference between the inverter and motor capacities is large and the setting is small, the protective characteristics of the electronic over current protection will be deteriorated. In this case, use an external thermal relay.

A special motor cannot be protected by the electronic thermal relay function. Use an external thermal relay.

PTC thermistor output built-in the motor can be input to the PTC signal (AU terminal). (For details refer to section 3.3.)



### 5.1.2 When the rated motor frequency is 60Hz (Pr. 3) V/F

First, check the motor rating plate. If a frequency given on the rating plate is "60Hz" only, always set Pr. 3 "Base frequency" to "60Hz".

Pr. No.	Name	Initial Value	Setting Range	Description
<b>3</b>	Base frequency	50Hz	0-400Hz	Set the rated motor frequency.

**Example** ▾ Change Pr. 3 "Base frequency" to 60Hz according to the motor rated frequency.

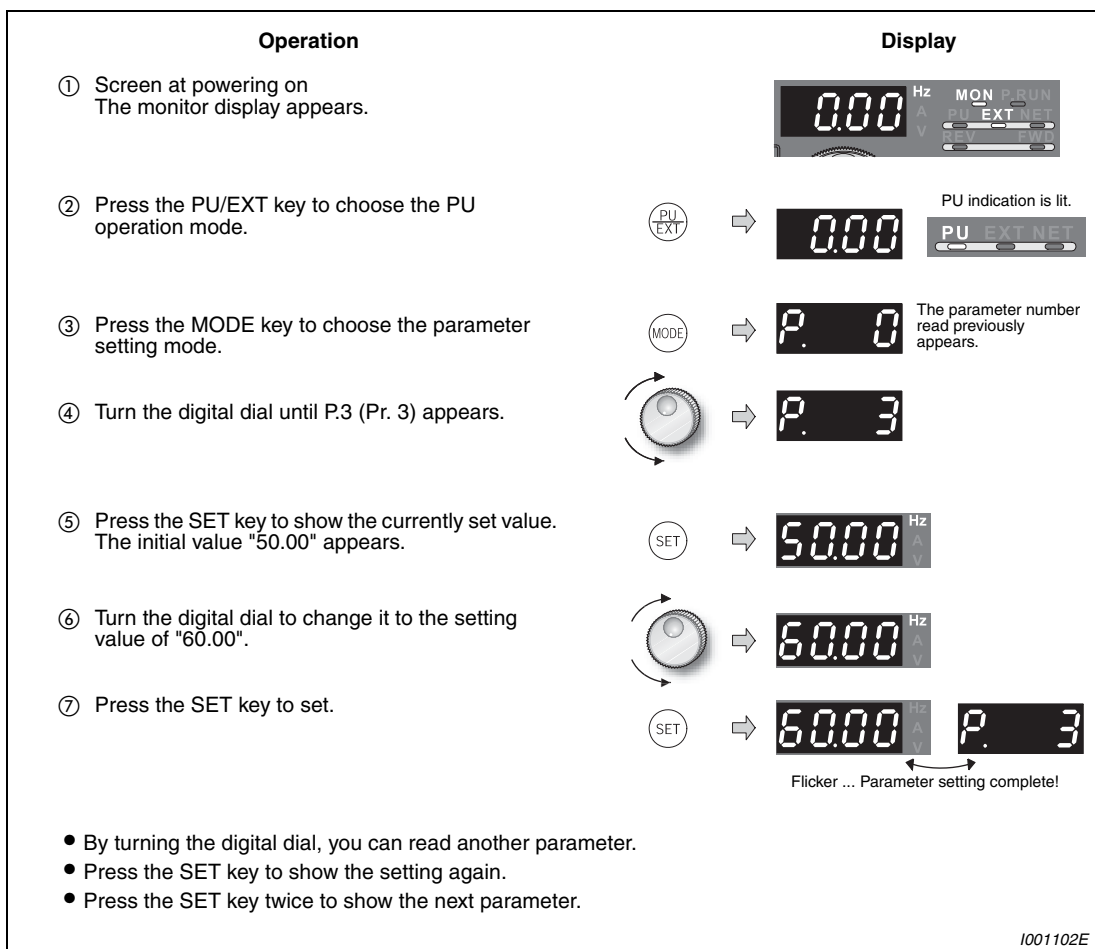

**Fig. 4-2:** Setting the base frequency



**NOTE**

Pr. 3 is invalid under advanced magnetic flux vector control, real sensorless vector control, and vector control and Pr. 84 "Rated motor frequency" is valid.

### 5.1.3 Increase the starting torque (Pr. 0)

Set this parameter when the motor with a load does not rotate, an alarm OL is output, resulting in an inverter trip due to OC1, etc.

Pr. No.	Name	Initial Value		Setting Range	Description
0	Torque boost	00023, 00038	6%	0-30%	Motor torque in the low-frequency range can be adjusted to the load to increase the starting motor torque.
		00052 to 00126	4%		
		00170/00250	3%		
		00310 to 01800	2%		
		02160 or more	1%		

#### Example ▽

When the motor with a load does not rotate, increase the Pr. 0 value 1% by 1% unit by looking at the motor movement. (The guideline is for about 10% change at the greatest.)

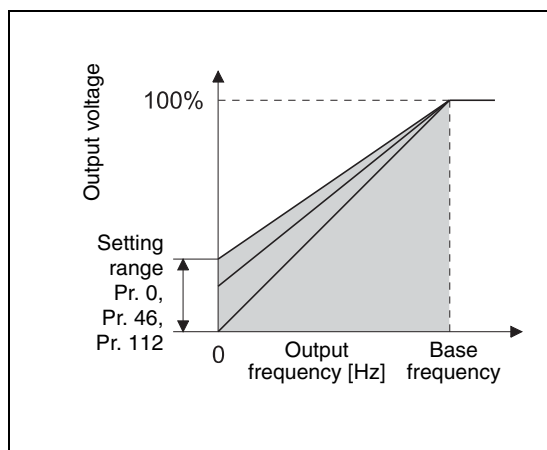

**Fig. 5-3:**  
Relation between output frequency and output voltage

I001098E

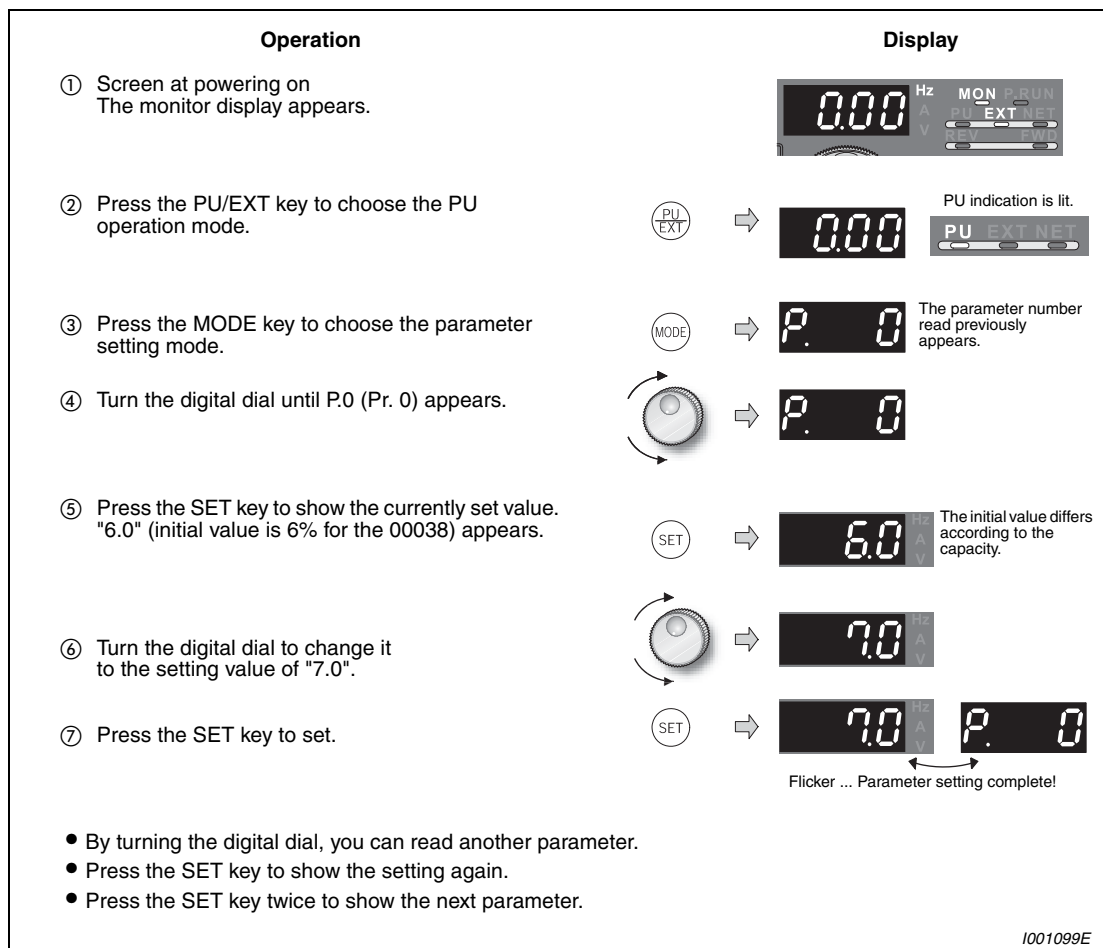

**Fig. 5-4:** Setting the starting torque



**NOTES**

A too large setting will cause the motor to overheat, resulting in an over current trip (OL (over current alarm) then E.OC1 (over current shutoff during acceleration)), thermal trip (E.THM (Motor overload shutoff), and E.THT (Inverter overload shutoff)).  
When an error (E.OC1) occurs, release the start command, and decrease the value 1% by 1%. (Refer to page 7-11.)

If the inverter still does not operate properly after the above measures, adjust the acceleration/deceleration setting, activate the vector control function by Pr. 80 "Simple magnetic vector control" (refer to section 6.7.2.) and 81 "Number of motor poles" and activate the real sensorless vector control by Pr. 800. The Pr. 0 setting is invalid under advanced magnetic flux vector control, real sensorless vector control and vector control.

### 5.1.4 Limit the maximum and minimum output frequency (Pr. 1, Pr. 2)

Pr. No.	Name	Initial Value		Setting Range	Description
1	Maximum frequency	01800 or less	120Hz	0-120Hz	Set the upper limit of the output frequency.
		02160 or more	60Hz		
2	Minimum frequency	0Hz		0-120Hz	Set the lower limit of the output frequency.

#### Example ▾

You can limit the motor speed. Limit the frequency set by the potentiometer, etc. to 50Hz maximum. (Set "50"Hz to Pr. 1 "Maximum frequency".)

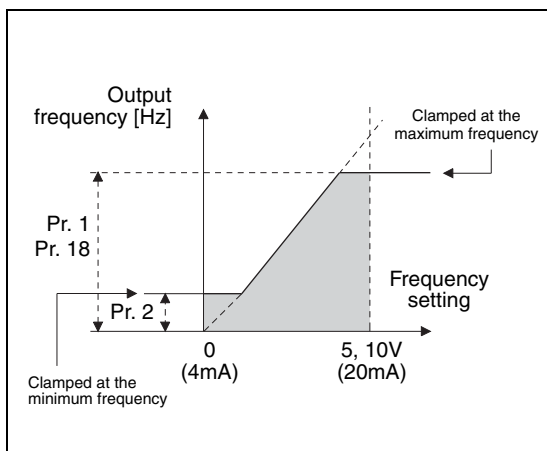

**Fig. 5-5:**

*Minimum and maximum output frequency*

1001100E

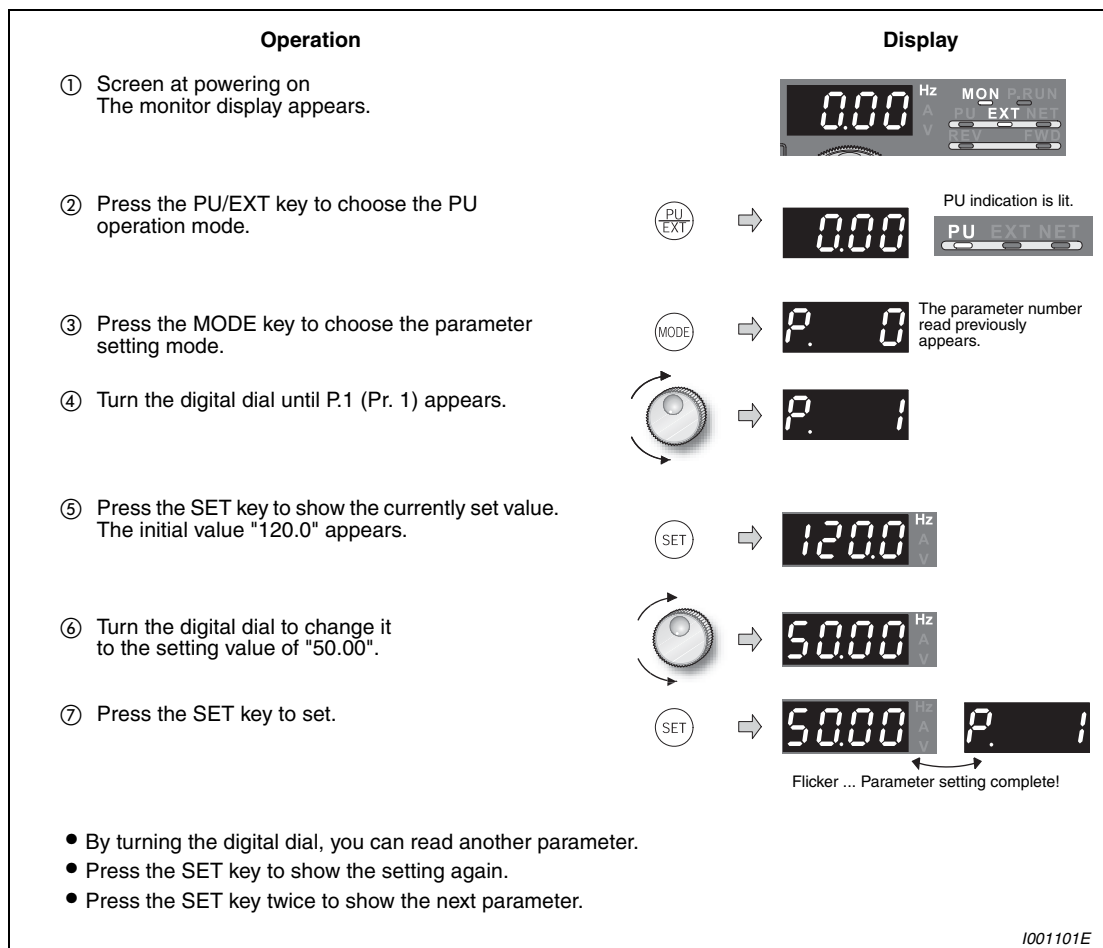

**Fig. 5-6:** Setting the maximum frequency



**NOTES**

The output frequency is clamped by the Pr. 2 setting even the set frequency is lower than the Pr. 2 setting (The frequency will not decrease to the Pr. 2 setting.) Note that Pr.15 "Jog frequency" has higher priority than the minimum frequency.

When the Pr. 1 setting is changed, frequency higher than the Pr. 1 setting can not be set by the digital dial.

When performing a high speed operation at 120Hz or more, setting of Pr. 18 "High speed maximum frequency" is necessary. (Refer to section 6.8.1.)



**CAUTION:**

**If the Pr. 2 setting is higher than the Pr. 13 "Starting frequency" value, note that the motor will run at the set frequency according to the acceleration time setting by merely switching the start signal on, without entry of the command frequency.**

### 5.1.5 Change the acceleration/deceleration time (Pr. 7, Pr. 8)

Set in Pr. 7 "Acceleration time" a larger value for a slower speed increase and a smaller value for a faster speed increase.

Set in Pr. 8 "Deceleration time" a larger value for a slower speed decrease and a smaller value for a faster speed decrease.

Pr. No.	Name	Initial Value		Setting Range	Description
7	Acceleration time	00250 or less	5s	0-3600s/ 0-360s <sup>①</sup>	Set the motor acceleration time.
		00310 or more	15s		
8	Deceleration time	00250 or less	5s	0-3600s/ 0-360s <sup>①</sup>	Set the motor deceleration time.
		00310 or more	15s		

① Depends on the Pr. 21 "Acceleration/deceleration time increments" setting. The initial value for the setting range is "0 to 3600s" and setting increments is "0.1s".

#### NOTE

Too short acceleration/deceleration times may lead to an inverter shutoff with error message (E.THT, E.THM, E.OCT, E.OVT ...).

#### Example ▾

Change the Pr. 7 "Acceleration time" setting from "5s" to "10s".

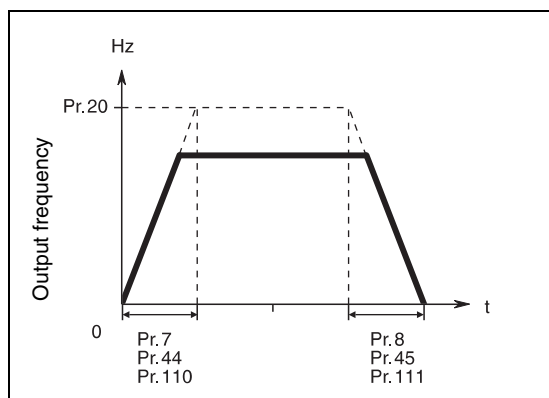

**Fig. 5-7:**  
Beschleunigungs-/Verzögerungszeit

1001466E

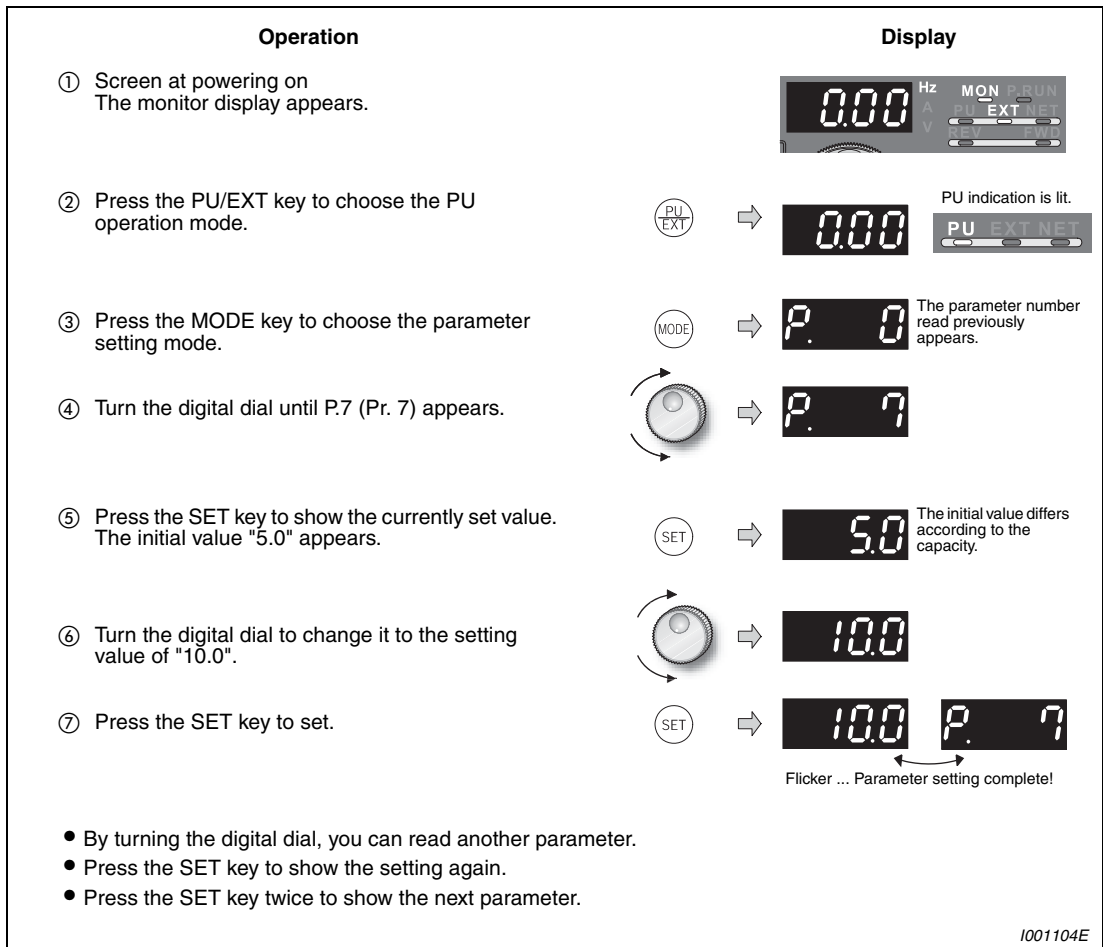



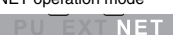



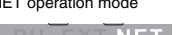



**Fig. 5-8:** Setting the acceleration time



## 5.1.6 Operation mode (Pr. 79)

Select the operation command location and frequency command location.

Pr. No.	Name	Initial Value	Setting Range	Description	LED Indication	
					<input type="checkbox"/> : OFF <input checked="" type="checkbox"/> : ON	
79	Operation mode selection	0	0	External/PU switch over mode Press the PU/EXT key to switch between the PU and external operation mode. (Refer to section 5.2.) At power on, the inverter is in the external operation mode.	External operation mode  PU operation mode 	
			1	PU operation mode		
			2	Fixed to external operation mode Operation can be performed by switching between the external and Net operation mode.	External operation mode  NET operation mode 	
			3	External/PU combined operation mode 1	Running frequency      Start signal PU (FR-DU07/FR-PU04) setting or external signal input (multi-speed setting, across terminals 4-5 (valid when AU signal turns on)). External signal input (terminal STF-, STR)	
				External/PU combined operation mode 2		
			6	Switch-over mode Switch among PU operation, external operation, and NET operation while keeping the same operation status.	PU operation mode  External operation mode  NET operation mode 	
			7	External operation mode (PU operation interlock) X12 signal ON ①: Operation mode can be switched to the PU operation mode. (output stop during external operation) X12 signal OFF ①: Operation mode can not be switched to the PU operation mode.	PU operation mode  External operation mode 	

① For the terminal used for the X12 signal (PU operation interlock signal) input, assign "12" in Pr. 178 to Pr. 189 "input terminal function selection" to assign functions. For Pr. 178 to Pr. 189, refer to section 6.14.1. When the X12 signal is not assigned, function of the MRS signal switches from MRS (output stop) to PU operation interlock signal.



### 5.1.7 Large starting torque and low speed torque are necessary (advanced magnetic flux vector control, real sensorless vector control) (Pr. 9, Pr. 71, Pr. 80, Pr. 81, Pr. 800) Magnetic flux Sensorless

Advanced magnetic flux vector control can be selected by setting the capacity, poles and type of the motor used in Pr. 80 and Pr. 81. When higher accuracy and fast response control is necessary, select the real sensorless vector control and perform offline auto tuning and online auto tuning.

- What is advanced magnetic flux vector control?  
The low speed torque can be improved by providing voltage compensation so that the motor current which meets the load torque to flow. Output frequency compensation (slip compensation) is made so that the motor actual speed approximates a speed command value. Effective when load fluctuates drastically, etc.
- What is real sensorless vector control?  
This function enables vector control with a general-purpose motor without encoder. It is suitable for applications below.
  - To minimize the speed fluctuation even at a severe load fluctuation
  - To generate low speed torque
  - To perform torque control

Pr. No.	Name	Initial Value	Setting Range		Description	
9	Electronic thermal O/L relay	Inverter rated output current ①	01800 or less	0–500A	Set the rated motor current.	
			02160 or more	0–3600A		
71	Applied motor	0	0–8/13–18/20/23/24/30/33/34/40/43/44/50/53/54		By selecting a standard motor or constant-torque motor, thermal characteristic and motor constants of each motor are set.	
80	Motor capacity	9999	01800 or less	0.4–55kW	Set the applied motor capacity.	
			02160 or more	0–3600kW		
			9999		V/f control	
81	Number of motor poles	9999	2/4/6/8/10		Set the number of motor poles.	
			12/14/16/18/20	X18 signal-ON: V/f control ②	Set 10 + number of motor poles.	
			9999	V/f control		
800	Control method selection	20	0–5		Vector control (Refer to page 5-18.)	
			9		Vector control test operation	
			10	Speed control	Real sensorless vector control	
			11	Torque control		
			12	MC signal-ON: torque MC signal-OFF: speed ②		
			20		V/f control (advanced magnetic flux vector control)	

① The initial value of the 00023 and 00038 is set to 85% of the rated inverter current.

② Use Pr. 178 to Pr. 189 to assign the terminals used for the X18 and MC signal.

If the following conditions are not satisfied, select V/f control since malfunction such as insufficient torque and uneven rotation may occur.

- The motor capacity should be equal to or one rank lower than the inverter capacity.
- Motor to be used is either Mitsubishi standard motor, high efficiency motor (SF-JR, SF-HR two-pole, four-pole, sixpole 0.4kW or more) or Mitsubishi constant-torque motor (SF-JRCA, SF-HRCA four-pole 0.4kW to 55kW). When using a motor other than the above (other manufacturer's motor), perform offline auto tuning without fail. (advanced magnetic flux vector control)  
When performing real sensorless vector control, offline auto tuning are necessary even when Mitsubishi motor is used.
- Single-motor operation (one motor run by one inverter) should be performed.
- The wiring length from inverter to motor should be within 30m. (Perform offline auto tuning in the state where actual wiring work is performed when the wiring length exceeds 30m.)

**NOTES**

Uneven rotation slightly increases as compared to the V/f control. (It is not suitable for machines such as grinding machine and wrapping machine which requires less uneven rotation at low speed.)

When terminal assignment is changed using Pr. 178 to Pr. 189 "Input terminal function selection", other functions may be affected. Please make setting after confirming the function of each terminal.

When advanced magnetic flux vector control is performed with an output filter, output torque may decrease. In addition, do not use a sine wave filter.

Do not perform real sensorless vector control with an output filter.

When you consider to use output filters, please contact your Mitsubishi sales representative.

**Selection method of advanced magnetic flux vector control**

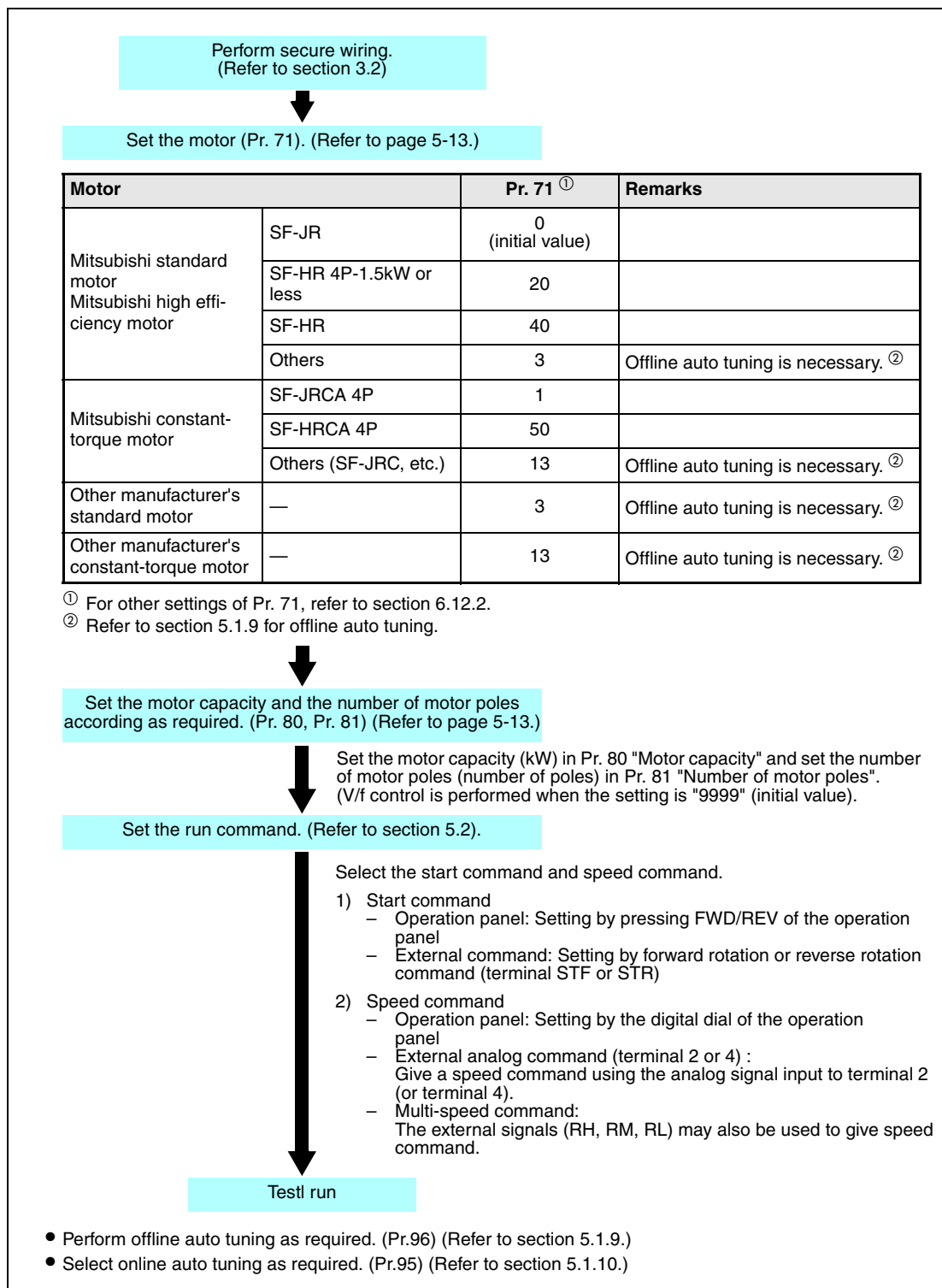

**Fig. 5-9:** Selection of the advanced magnetic flux vector control

**NOTES**

When higher accuracy operation is necessary, set online auto tuning after performing offline auto tuning and select real sensorless vector control.

Use Pr. 89 to adjust the motor speed fluctuation at load fluctuation. (Refer to section 6.7.2.)

### Selection method of real sensorless vector control (speed control)

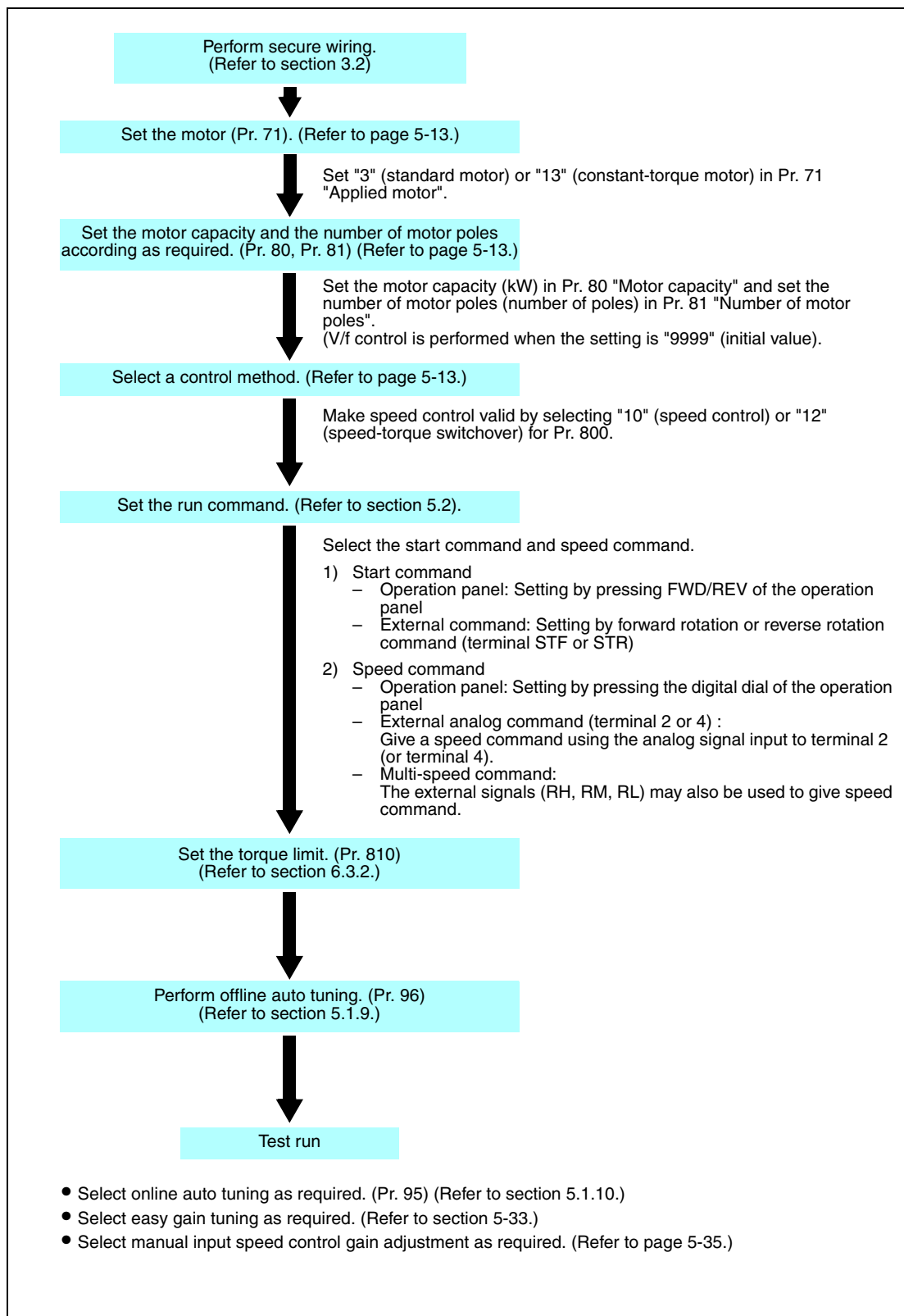

**Fig. 5-10:** Selection of the real sensorless vector control

**NOTES**

Make sure to perform offline auto tuning before performing real sensorless vector control.

The carrier frequencies are selectable from among 2k, 6k, 10k, 14kHz for real sensorless vector control.

Torque control can not be performed in the low speed region and at a low speed with light load. Choose vector control.

Do not switch between the STF (forward rotation command) and STR (reverse rotation command) during operation under torque control. Overcurrent shut-off error (E.OC□) or opposite rotation deceleration error (E.11) occurs.

When the inverter is likely to start during motor coasting under real sensorless vector control, set to make frequency search of automatic restart after instantaneous power failure valid (Pr. 57 ≠ 9999, Pr. 162 = 10).

**CAUTION:**

- ***Performing pre-excitation (LX signal and X13 signal) under torque control may start the motor running at a low speed even when the start command (STF or STR) is not input. The motor may run also at a low speed when the speed limit value = 0 with a start command input. Perform pre-excitation after making sure that there will be no problem in safety if the motor runs.***
- ***For the 00023 to 00126, the speed deviation may become large at 20Hz or less and torque may become insufficient in the low speed region under 1Hz during continuous operation under real sensorless vector control. In such case, stop operation once and reaccelerate to improve the problems.***

### 5.1.8 Higher accuracy operation using a motor with encoder (Vector control) (Pr. 9, Pr. 71, Pr. 80, Pr. 81, Pr. 359, Pr. 369, Pr. 800)



Full-scale vector control can be performed fitting the FR-A7AP and using a motor with encoder. Fast response/high accuracy speed control (zero speed control, servo lock), torque control, and position control can be performed.

- What is vector control?

Excellent control characteristics when compared to V/f control and other control techniques, achieving the control characteristics equal to those of DC machines.

It is suitable for applications below.

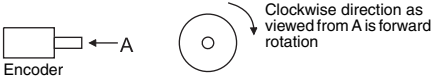
- To minimize the speed fluctuation even at a severe load fluctuation
- To generate low speed torque
- To perform torque control or position control
- Servo-lock torque control which generates a torque at zero speed (i.e. status of motor shaft = stopped)

Pr. No.	Name	Initial Value	Setting Range		Description	
<b>9</b>	Electronic thermal O/L relay	Inverter rated output current ①	01800 or less	0-500A	Set the rated motor current.	
			02160 or more	0-3600A		
<b>71</b>	Applied motor	0	0-8/13-18/20/23/24/30/33/34/40/43/44/50/53/54		By selecting a standard motor or constant-torque motor, thermal characteristic and motor constants of each motor are set.	
<b>80</b>	Motor capacity	9999	01800 or less	0.4-55kW	Set the applied motor capacity.	
			02160 or more	0-3600kW		
			9999	V/f-Regelung aktiviert		
<b>81</b>	Number of motor poles	9999	2/4/6/8/10		Set the number of motor poles.	
			12/14/16/18/20		X18 signal-ON: V/f control ②	Set 10 + number of motor poles.
			9999		V/f control	
<b>359</b>	Encoder rotation direction	1	0			
			1			
<b>369</b>	Number of encoder pulses	1024	0-4096		Set the number of pulses of the encoder. Set the number of pulses before multiplied by four.	
<b>800</b>	Control method selection	20	0	Speed control	Vector control	
			1	Torque control		
			2	MC signal-ON: torque MC signal-OFF: speed ②		
			3	Position control		
			4	MC signal-ON: position MC signal-OFF: speed ②		
			5	MC signal-ON: torque MC signal-OFF: position ②		
			9	Vector control test operation (Refer to section 6.2.2)		
			10-12	Real sensorless vector control (Refer to page 5-16.)		
			20	V/f control (advanced magnetic flux vector control)		

① The initial value of the 00023 and 00038 is set to 85% of the rated inverter current.

② Use Pr. 178 to Pr. 189 to assign the terminals used for the X18 and MC signal.

If the conditions below are not satisfied, malfunction such as insufficient torque and uneven rotation may occur.

- The motor capacity should be equal to or one rank lower than the inverter capacity.
- Motor to be used is either Mitsubishi standard motor with encoder, high efficiency motor (SF-JR, SF-HR two-pole, four-pole, six-pole 0.4kW or more) or Mitsubishi constant-torque motor (SF-JRCA, SF-HRCA four-pole 0.4kW to 55kW) or vector control dedicated motor (SF-V5RU). When using a motor other than the above (other manufacturer's motor), perform offline auto tuning without fail.
- Single-motor operation (one motor run by one inverter) should be performed.
- Wiring length from inverter to motor should be within 30m. (Perform offline auto tuning in the state where wiring work is performed when the wiring length exceeds 30m.)

**NOTE**

Changing the terminal assignment using Pr. 178 to Pr. 189 "Input terminal function selection" may affect the other functions. Make setting after confirming the function of each terminal.

**CAUTION:**

*Do not perform vector control with an output filter connected.*



### Selection method of speed control

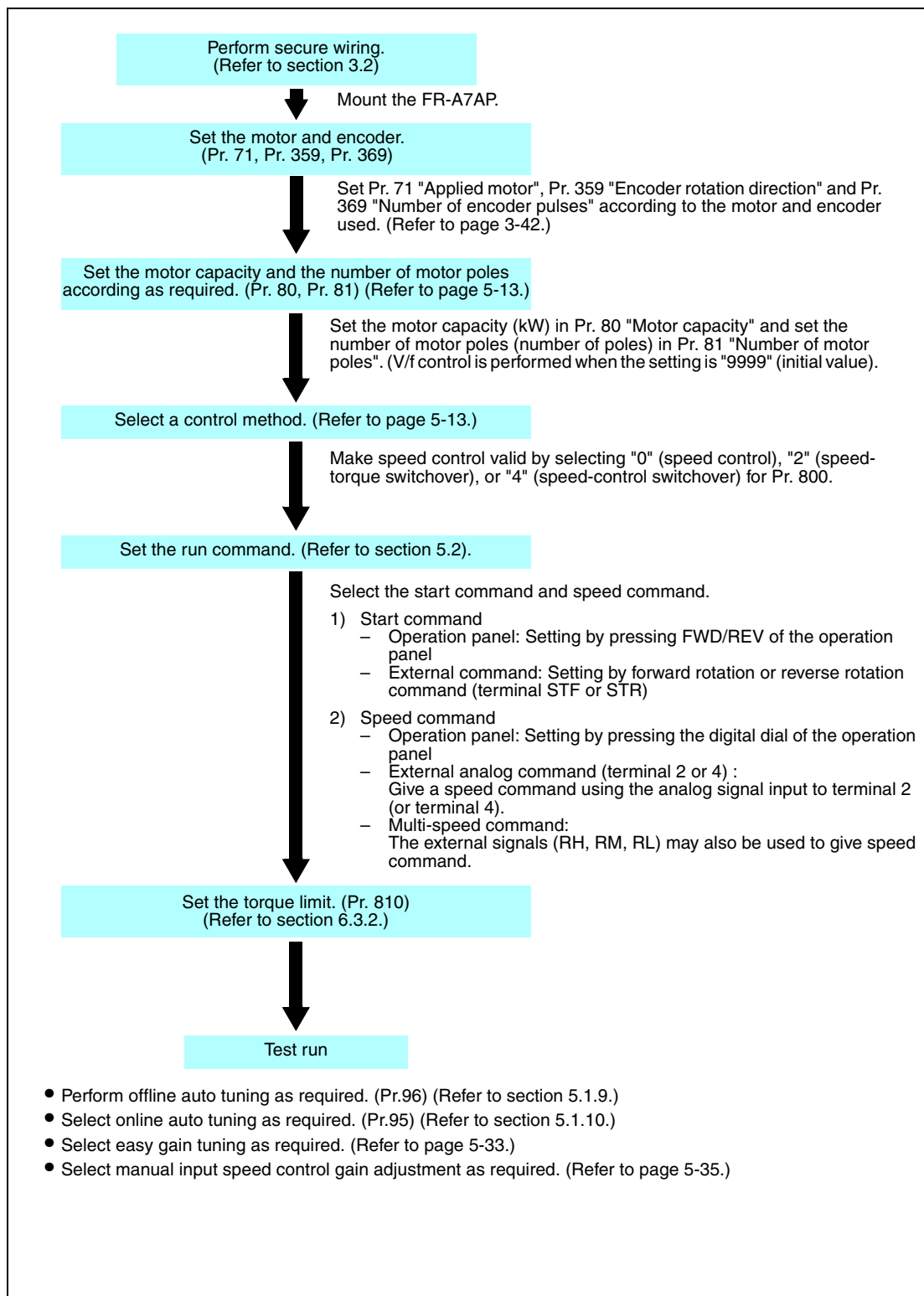

**Fig. 5-11:** Selection of speed control

### Selection method of torque control

- Torque control is exercised to develop torque as set in the torque command.
- The motor speed becomes constant when the motor output torque and load torque are balanced. For torque control, therefore, the speed is determined by the load.
- For torque control, the motor gains speed as the motor output torque becomes greater than the motor load. To prevent overspeed, set the speed limit value so that the motor speed does not increase too high. (Speed control is exercised during speed limit and torque control is disabled.)
- When speed limit is not set, the speed limit value setting is regarded as 0Hz to disable torque control.

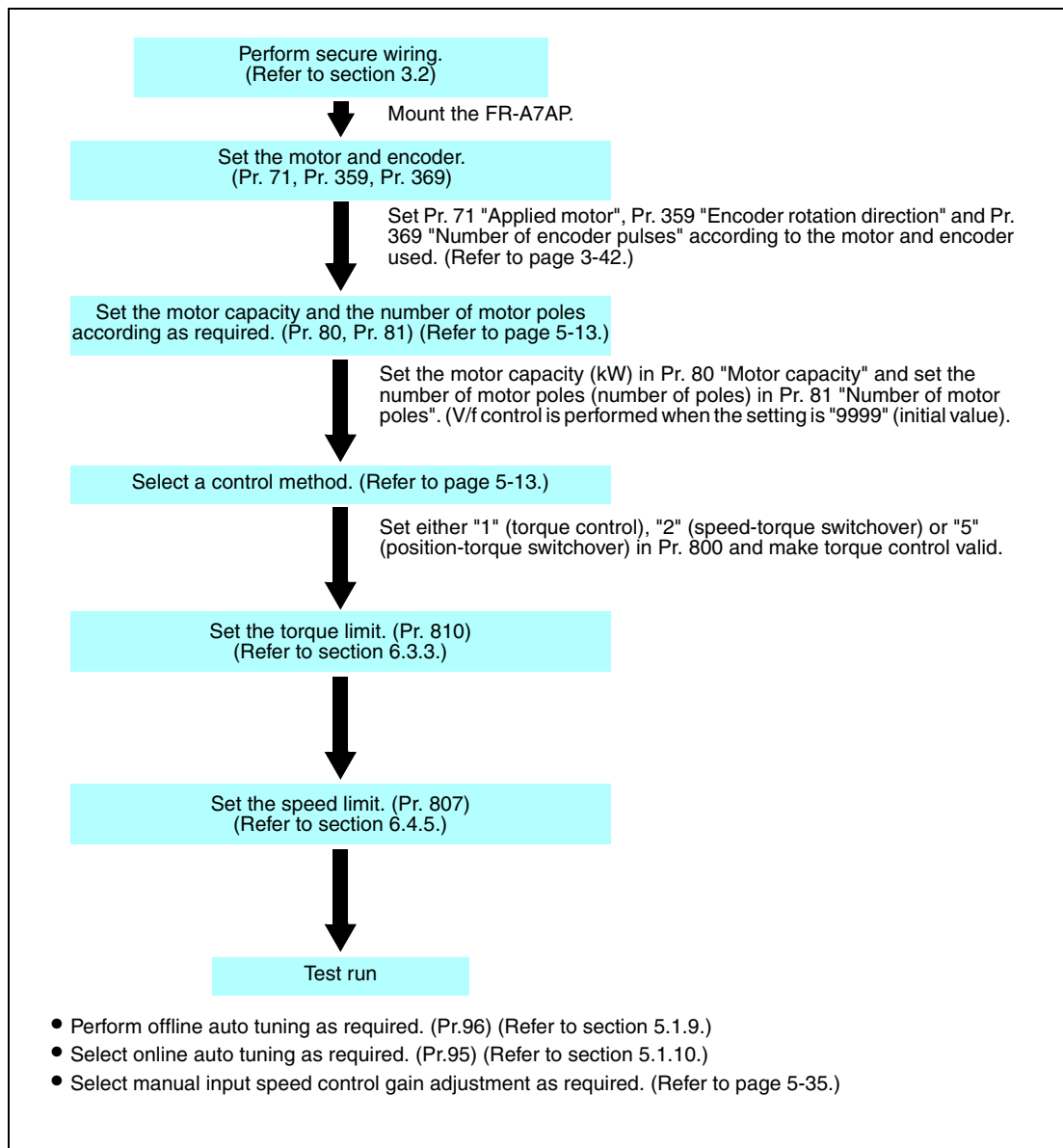

**Fig. 5-12:** Selection of torque control

**Selection method of position control**

- In the position control, the speed command is calculated so that the difference between command pulse (or parameter setting) and the number of feedback pulses from the encoder is zero to run the motor.
- This inverter can perform conditional position feed by contact input and position control by inverter conditional pulse input..

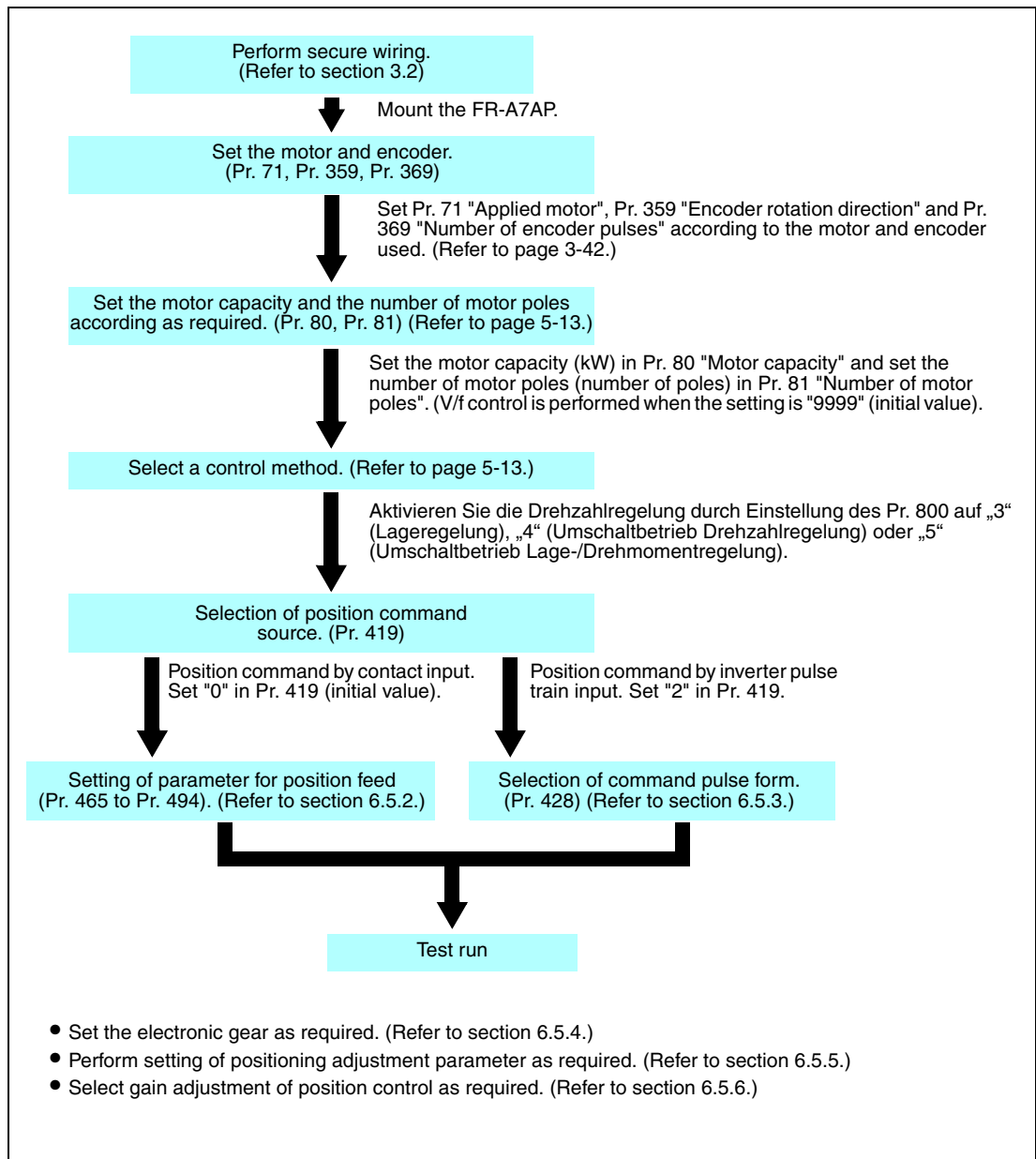

**Fig. 5-13:** Selection of position control

## 5.1.9 To exhibit the best performance of the motor performance (offline auto tuning) (Pr. 9, Pr. 71, Pr. 83, Pr. 84, Pr. 96) Magnetic flux Sensorless Vector

The motor performance can be maximized with offline auto tuning.

- What is offline auto tuning?

When performing advanced magnetic flux vector control, real sensorless vector control or vector control, the motor can be run with the optimum operating characteristics by automatically measuring the motor constants (offline auto tuning) even when each motor constants differs, other manufacturer's motor is used, or the wiring length is long.

Pr. No.	Name	Initial Value	Setting Range	Description	
9	Electronic thermal O/L relay	Inverter rated output current ①	01800 or less	0-500A	Set the rated motor current.
			02160 or more	0-3600A	
71	Applied motor	0	0-8/13-18/20/23/24/30/33/34/40/43/44/50/53/54	By selecting a standard motor or constant-torque motor, thermal characteristic and motor constants of each motor are set.	
83	Motor rated voltage	400V	0-1000V	Set the rated motor voltage (V).	
84	Rated motor frequency	50 Hz	10-120Hz	Set the rated motor frequency (Hz).	
96	Auto tuning setting/status	0	0	Offline auto tuning is not performed	
			1	Offline auto tuning is performed without motor running	
			101	Offline auto tuning is performed with motor running	

① The initial value of the 00023 and 00038 is set to 85% of the rated inverter current.

- This function is made valid only when a value other than "9999" is set in Pr. 80 and Pr. 81 and advanced magnetic flux vector control or real sensorless vector control is selected.
- You can copy the offline auto tuning data (motor constants) to another inverter with the PU (FR-PU04/FR-PU07/FR-DU07).
- Even when motors (other manufacturer's motor, SF-JRC, etc.) other than Mitsubishi standard motor, high efficiency motor (SF-JR SF-HR 0.4kW or more), Mitsubishi constant-torque motor (SF-JRCA, SF-HRCA four-pole 0.4kW to 55kW) and vector control dedicated motor (SF-V5RU) are used or the wiring length is long, using the offline auto tuning function runs the motor with the optimum operating characteristics.
- Tuning is enabled even when a load is connected to the motor. (As the load is lighter, tuning accuracy is higher. Tuning accuracy does not change even if the inertia is large.)
- For the offline auto tuning, you can select either the motor non-rotation mode (Pr. 96 = 1) or rotation mode. (Pr. 96 = 101). The rotation mode has higher tuning accuracy than the non-rotation mode.
- Reading/writing/copy of motor constants tuned by offline auto tuning are enabled.
- The offline auto tuning status can be monitored with the PU.
- Do not connect an output filter to the 01800 or less and sine wave filter to the 02160 or more between the inverter and motor.

**Before performing offline auto tuning**

Check the following before performing offline auto tuning.

- Make sure advanced magnetic flux vector control (Pr. 80, Pr. 81), real sensorless vector control or vector control (Pr. 800) is selected. (Refer to section 5.1.7.)
- A motor should be connected. Note that the motor should be at a stop at a tuning start.
- The motor capacity should be equal to or one rank lower than the inverter capacity. (note that the capacity is 0.4kW or more)
- The maximum frequency is 120Hz.
- Motors such as high-slip motor, high-speed motor and special motor cannot be tuned.
- Even if tuning is performed without motor running (Pr. 96 "Auto tuning setting/status" = 1), the motor may run slightly. Therefore, fix the motor securely with a mechanical brake, or before tuning, make sure that there will be no problem in safety if the motor runs. (Caution is required especially in vertical lift applications). Note that if the motor runs slightly, tuning performance is unaffected.
- Note the following when selecting offline auto tuning performed with motor running (Pr. 96 "Auto tuning setting/status" = 101).
  - Torque is not enough during tuning.
  - The motor may be run at nearly its rated speed.
  - The brake is open.
  - No external force is applied to rotate the motor.
- Offline auto tuning will not be performed properly if it is performed with an output filter connected to the 01800 or less and sine wave filter connected to the 02160 or more between the inverter and motor. Remove it before starting tuning.
- When exercising vector control, use the encoder that is coupled directly to the motor shaft without looseness. Speed ratio should be 1 : 1.

**Setting**

Set "1" or "101" in Pr. 96 "Auto tuning setting/status".

- When the setting is "1"  
Tuning is performed without motor running. It takes approximately 25 to 120s\* until tuning is completed. (Excitation noise is produced during tuning.)  
(\* Tuning time differs according to the inverter capacity and motor type.)
- When the setting is "101"  
Tuning is performed without motor running. It takes approximately 40s until tuning is completed. The motor runs at nearly its rated frequency.

Set the rated voltage of motor in Pr. 83 "Motor rated voltage" and rated frequency of motor in Pr. 84 "Rated motor frequency".

Set Pr. 71 "Applied motor" according to the motor used.

Motor		Pr. 71 ①
Mitsubishi standard motor, Mitsubishi high efficiency motor	SF-JR, SF-TH	3
	SF-JR 4P-1.5kW or less	23
	SF-HR	43
	Others	3
Mitsubishi constant-torque motor	SF-JRCA 4P, SF-TH (constant-torque)	13
	SF-HRCA 4P	53
	Others (SF-JRC, etc.)	13
Vector control dedicated motor	SF-V5RU, SF-THY	33
Other manufacturer's standard motor	—	3
Other manufacturer's constant-torque motor	—	13

**Tab. 5-3: Motor selection**

① For other settings of Pr. 71 , refer to section 6.12.2.

## Execution of tuning

**CAUTION:**

***Before performing tuning, check the monitor display of the operation panel (FR-DU07) or parameter unit (FR-PU04/FRPU07) if the inverter is in the state ready for tuning (refer to Tab. 5-4). When the start command is turned on under V/f control, the motor starts.***

When performing PU operation, press the FWD or REV key of the operation panel.

For external operation, turn on the run command (STF signal or STR signal). Tuning starts.

**NOTES**

When selecting offline auto tuning performed with motor running (Pr. 96 "Auto tuning setting/status" = 101), caution must be taken since the motor runs.

To force tuning to end, use the MRS or RES signal or press the STOP/RESET key of the operation panel. (Turning the start signal (STF signal or STR signal) off also ends tuning.)

During offline auto tuning, only the following I/O signals are valid:

–Input signals:

STOP, OH, MRS, RT, CS, RES, STF, and STR

–Output terminal:

RUN, OL, IPF, CA, AM, A1, B1, and C1

Note that the progress status of offline auto tuning is output from AM and CA when speed and output frequency are selected.

Since the RUN signal turns on when tuning is started, caution is required especially when a sequence which releases a mechanical brake by the RUN signal has been designed.

When executing offline auto tuning, input the run command after switching on the main circuit power (R/L1, S/L2, T/L3) of the inverter.

Do not perform ON/OFF switching of the second function selection signal (RT) during execution of offline auto tuning. Auto tuning is not executed properly.

Setting offline auto tuning (Pr. 96 "Auto tuning setting/status" = 1 or 101) will make pre-excitation invalid.

### Display during tuning

Monitor is displayed on the parameter unit (FR-DU07/FR-PU04/FR-PU07) during tuning as below. The monitored value is the value of parameter 96..

	Parameter unit FR-PU07/FR-PU04 Display		Parameter unit FR-DU07 Display	
	1	101	1	101
Setting				
Tuning in progress				
Normal end				
Error end (when inverter protective function operation is activated)				

**Tab. 5-4:** Display during tuning (monitor display)

Offline Auto Tuning Setting	Time
Non-rotation mode (Pr. 96 = 1)	Approximately 25 to 120s (Tuning time differs according to the inverter capacity and motor type.)
Rotation mode (Pr. 96 = 101)	Approximately 40s (Offline auto tuning time varies with the acceleration and deceleration time settings as indicated below. Offline auto tuning time = acceleration time + deceleration time + approx. 30s)

**Tab. 5-5:** Offline auto tuning time (when the initial value is set)

### Return to normal operation

When offline auto tuning ends, press the STOP/RESET key of the operation panel during PU operation. For external operation, turn off the start signal (STF signal or STR signal). This operation resets the offline auto tuning and the PU's monitor display returns to the normal indication. (Without this operation, next operation cannot be started.)

**NOTE**

Do not change the Pr. 96 setting after completion of tuning (3 or 103). If the Pr. 96 setting is changed, tuning data is made invalid. If the Pr. 96 setting is changed, tuning must be performed again.



If offline auto tuning ended in error (see the table below), motor constants are not set. Perform an inverter reset and restart tuning.

Pr. 96 Setting	Error Cause	Remedy
8	Forced end	Set "1" or "101" in Pr. 96 and perform tuning again.
9	Inverter protective function operation	Make setting again.
91	Current limit (stall prevention) function was activated.	Increase acceleration/deceleration time. Set "1" in Pr. 156 .
92	Converter output voltage reached 75% of rated value.	Check for fluctuation of power supply voltage.
93	– Calculation error – A motor is not connected.	Überprüfen Sie den Motoranschluss und wiederholen Sie die Selbsteinstellung.

**Tab. 5-6:** Parameter 96 setting

When tuning is ended forcibly by pressing the STOP/RESET key or turning off the start signal (STF or STR) during tuning, offline auto tuning does not end normally. (The motor constants have not been set.) Perform an inverter reset and restart tuning.

#### NOTES

The motor constants measured once in the offline auto tuning are stored as parameters and their data are held until the offline auto tuning is performed again.

An instantaneous power failure occurring during tuning will result in a tuning error. After power is restored, the inverter goes into the normal operation mode. Therefore, when STF (STR) signal is on, the motor runs in the forward (reverse) rotation.

Any alarm occurring during tuning is handled as in the ordinary mode. Note that if an error retry has been set, retry is ignored.

The set frequency monitor displayed during the offline auto tuning is 0Hz.



#### CAUTION:

- **Note that the motor may start running suddenly.**
- **When the offline auto tuning is used in vertical lift application, e.g. a lifter, it may drop due to insufficient torque.**

### 5.1.10 High accuracy operation unaffected by the motor temperature (online auto tuning) Magnetic flux Sensorless Vector

When online auto tuning is selected under advanced magnetic flux vector control, real sensorless vector control or vector control, excellent torque accuracy is provided by temperature compensation even if the secondary resistance value of the motor varies with the rise of the motor temperature.

Pr. No.	Name	Initial Value	Setting Range	Description
95	Online auto tuning selection	0	0	Online auto tuning is not performed
			1	Start-time online auto tuning
			2	Magnetic flux observer (normal tuning)

#### Start-time online auto tuning (Pr. 96 = 1)

- By quickly tuning the motor constants at a start, high accuracy operation unaffected by the motor temperature and stable operation with high torque down to ultra low speed can be performed.
- Make sure advanced magnetic flux vector control (Pr. 80, Pr. 81 ) or real sensorless vector control (Pr.800 ) is selected. (Refer to section 5.1.7.)
- Before performing online auto tuning, perform offline auto tuning without fail.

Operation method:

- ① Check that "3" or "103" (offline auto tuning completion) is set in Pr. 96 "Auto tuning setting/status".
- ② Set "1" (start-time online auto tuning) in Pr. 95 "Online auto tuning selection". Online auto tuning is performed from the next starting.
- ③ When performing PU operation, press the FWD or REV key of the operation panel. For external operation, turn on the run command (STF signal or STR signal).



#### CAUTION:

*For using start-time online auto tuning in vertical lift applications, examine the utilization of a brake sequence for the brake opening timing at a start. Torque is not provided fully during the tuning period. Therefore, note that there may be a possibility of drop due to gravity.*

**Magnetic flux observer (normal tuning) (Pr. 95 = 2)**

- When exercising vector control using a motor with encoder, it is effective for torque accuracy improvement. The current flowing in the motor and the inverter output voltage are used to estimate/observe the magnetic flux in the motor. The magnetic flux of the motor is always detected with high accuracy so that an excellent characteristic is provided regardless of the change in the temperature of the secondary resistance.
- Vector control (Pr. 80, Pr. 81, Pr. 800) should be selected. (Refer to section 5.1.8).

**NOTES**

For the SF-V5RU, SF-JR (with encoder), SF-HR (with encoder), SF-JRCA (with encoder) or SF-HRCA (with encoder), it is not necessary to perform offline auto tuning to select adaptive magnetic flux observer. (Note that it is necessary to perform offline auto tuning (non-rotation mode) for the wiring length resistance to be reflected on the control when the wiring length is long (30m or longer as reference).

Online auto tuning does not operate if the MRS signal is input, if the preset speed is less than the Pr. 13 "Starting frequency", or if the starting conditions of the inverter are not satisfied, e.g. inverter error.

Online auto tuning does not operate during deceleration or at a restart during DC brake operation.

Invalid for jog operation.

Automatic restart after instantaneous power failure overrides when automatic restart after instantaneous power failure is selected. (Start-time online auto tuning is not performed at frequency search.)

Perform online auto tuning at a stop with the X28 signal when using automatic restart after instantaneous power failure together. (Refer to page 6.12.4.)

Zero current detection and output current detection are valid during online auto tuning.

The RUN signal is not output during online auto tuning. The RUN signal turns on at a start.

If the period from an inverter stop to a restart is within 4s, start-time tuning is performed but the tuning results are not reflected.

### 5.1.11 To perform high accuracy / fast response operation (gain adjustment of real sensorless vector control) (Pr. 818 to Pr. 821, Pr. 880) Sensorless Vector

The ratio of the load inertia to the motor inertia (load inertia moment ratio) is estimated in real time from the torque command and speed during motor operation by vector control. As optimum gain of speed control and position control are automatically set from the load inertia ratio and response level, time and effort of making gain adjustment are reduced. (Easy gain tuning)

When the load inertia ratio can not be estimated due to load fluctuation or real sensorless vector control is exercised, control gain is automatically set by manually inputting the load inertia ratio. Make a manual input adjustment when vibration, noise or any other unfavorable phenomenon occurs due to large load inertia or gear backlash, for example, or when you want to exhibit the best performance that matches the machine..

Pr. No.	Name	Initial Value	Setting Range	Description
<b>818</b>	Easy gain tuning response level setting	2	1–15	Set the response level. 1: Slow response to 15: Fast response
<b>819</b>	Easy gain tuning selection	0	0	Without easy gain tuning
			1	With load estimation, with gain calculation (only under vector control and real sensorless vector control)
			2	With load (Pr. 880) manual input, gain calculation
<b>820</b>	Speed control P gain 1	60%	0–1000%	Set the proportional gain for speed control. (Increasing the value improves trackability in response to a speed command change and reduces speed variation with disturbance.)
<b>821</b>	Speed control integral time 1	0.333s	0–20s	Set the integral time during speed control. (Decrease the value to shorten the time taken for returning to the original speed if speed variation with disturbance occurs.)
<b>880</b>	Load inertia ratio	7	0–200	Set the load inertia ratio to the motor.

#### NOTE

The initial values of the control parameters above allow to perform a wide range of applications.

Maybe you have to change the initial values to optimise the control behaviour. For detailed information refer to section 6.3.4.

**Easy gain tuning execution procedure (Pr. 819 = 1 load inertia ratio automatic estimation)**

Easy gain tuning (load inertia ratio automatic estimation) is valid only in the speed control or position control mode under vector control. It is invalid under torque control, V/f control, advanced magnetic flux vector control and real sensorless vector control.

- ① Set the response level using Pr. 818 "Easy gain tuning response level setting". Refer to the diagram below and set the response level. Increasing the value will improve trackability to the command, but too high value will generate vibration.

Pr. 818	1	2	3	4	5	6	7	8	9	10	11	12	13	14	15
Response level	Slow response			← Middle response →						Fast response					
Guideline of machine resonance frequency [Hz]	8	10	12	15	18	22	28	34	42	52	64	79	98	122	150
Application															

1001482E

**Tab. 5-7:** Response level setting

- ② Each control gain is automatically set from the load inertia ratio estimated during acceleration/deceleration operation and the Pr. 818 "Easy gain tuning response level setting" value. Pr. 880 "Load inertia ratio" is used as the initial value of the load inertia ratio for tuning. Estimated value is set in Pr. 880 during tuning. The load inertia ratio may not be estimated well, e.g. it takes a long time for estimation, if the following conditions are not satisfied.
  - Time taken for acceleration/deceleration to reach 1500r/min is 5s or less.
  - Speed is 150r/min or more.
  - Acceleration/deceleration torque is 10% or more of the rated torque.
  - Abrupt disturbance is not applied during acceleration/deceleration.
  - Load inertia ratio is approx. 30 times or less.
  - No gear backlash nor belt looseness is found.
- ③ Press the FWD or REV key to estimate the load inertia ratio or calculate gain any time. (The operation command for external operation is the STF or STR signal.)

Easy gain tuning execution procedure (Pr. 819 = 2 load inertia manual input)

Easy gain tuning (load inertia ratio manual input) is valid only in the speed control under real sensorless vector control or in the speed control or position control mode under vector control.

- ① Set the load inertia ratio to the motor in Pr. 880 "Load inertia ratio".
- ② Set "2" (with easy gain tuning) in Pr. 819 "Easy gain tuning selection". Then, Pr. 820 "Speed control P gain 1" and Pr. 821 "Speed control integral time 1" are automatically set by gain calculation. Operation is performed in a gain adjusted status from the next operation.
- ③ Perform a test run and set the response level in Pr. 818 "Easy gain tuning response level setting". Increasing the value will improve trackability to the command, but too high value will generate vibration. (When "2" (parameter write enabled during operation) is set in Pr. 77 "Parameter write selection", response level adjustment can be made during operation.)

#### NOTES

When "1 or 2" is set in Pr. 819 and then returned the Pr. 819 setting to "0" after tuning is executed, tuning results which are set in each parameter remain unchanged.

When good tuning accuracy is not obtained after executing easy gain tuning due to disturbance and such, perform fine adjustment by manual input. Set "0" (without easy gain tuning) in Pr. 819.

The following table indicates the relationship between easy gain tuning function and gain adjustment parameter.

	Easy Gain Tuning Selection (Pr. 819 ) Setting		
	0	1	2
Load inertia ratio (Pr. 880)	Manual input	a) Inertia estimation result (RAM) by easy gain tuning is displayed. b) Set the value in the following cases: <ul style="list-style-type: none"> <li>● Every hour after power-on</li> <li>● When a value other than "1" is set in Pr. 819</li> <li>● When vector control is changed to other control (V/f control etc.) using Pr. 800</li> </ul> c) Write is enabled only during a stop (manual input)	Manual input
Speed control P gain 1 (Pr. 820) Speed control integral time 1 (Pr. 821) Model speed control gain (Pr. 828) Position loop gain (Pr. 422)	Manual input	a) Tuning result (RAM) is displayed. b) Set the value in the following cases: <ul style="list-style-type: none"> <li>● Every hour after power-on</li> <li>● When a value other than "1" is set in Pr. 819</li> <li>● When vector control is changed to other control (V/f control etc.) using Pr. 800</li> </ul> c) Write (manual input) disabled	a) Gain and integral time is calculated when "2" is set in Pr. 819 and the result is set in the parameter. b) When the value is read, the tuning result (parameter setting value) is displayed. c) Write (manual input) disabled

**Tab. 5-8:** Automatically set parameters by easy gain tuning



#### CAUTION:

**Performing easy gain tuning with larger inertia than the specified value during vector control may cause malfunction such as hunting. In addition, when the motor shaft is fixed with servo lock or position control, bearing may be damaged. To prevent these, make gain adjustment by manual input without performing easy gain tuning.**

**Manual input speed control gain adjustment**

Make adjustment when any of such phenomena as unusual machine vibration/noise, low response level and overshoot has occurred.

- Pr. 820 "Speed control P gain 1" = 60% (initial value) is equivalent to 120rad/s (speed response of the motor alone). Increasing the setting value improves the response level, but a too large gain will produce vibration and/or unusual noise.

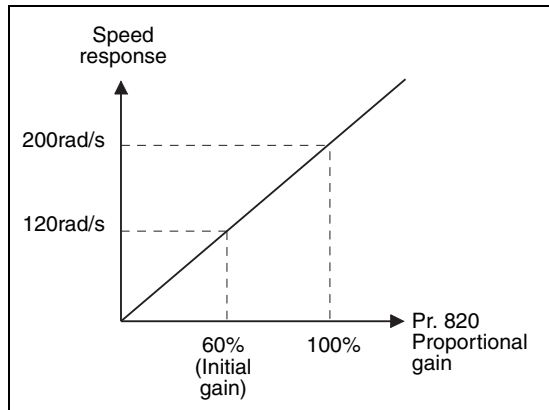

**Fig. 5-14:**  
Setting of the proportional gain

1001483E

- Decreasing the Pr. 821 "Speed control integral time 1" shortens the return time taken at a speed change. However, a too short time will generate an overshoot.
- When there is load inertia, the actual speed gain is as given below.

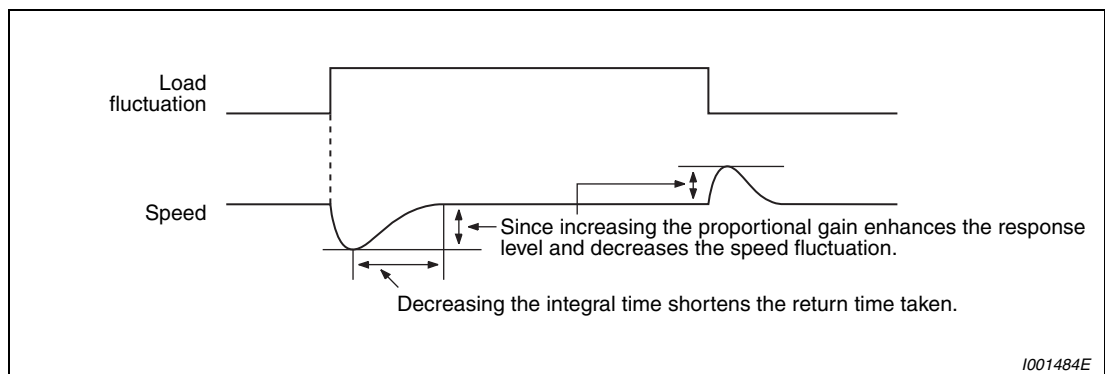

1001484E

**Fig. 5-15:** Speed characteristic at load fluctuation

Also, when there is load inertia, the actual speed gain decreases as indicated below.

$$\text{Actual speed gain} = \text{speed gain of motor without load} \times \frac{JM}{JM + JL}$$

JM: Inertia of the motor

JL: Motor shaft-equivalent load inertia

- Adjustment procedures are as below:  
Check the conditions and simultaneously change the Pr. 820 value.  
If you cannot make proper adjustment, change the Pr. 821 value and repeat the step above.

No	Phenomenon/Condition	Adjustment Method	
1	Load inertia is large	Set the Pr. 820 and Pr. 821 values a little higher.	
		Pr. 820	When a speed rise is slow, increase the value 10% by 10% until just before vibration/noise is produced, and set about 0.8 to 0.9 of that value.
		Pr. 821	If an overshoot occurs, double the value until an overshoot does not occur, and set about 0.8 to 0.9 of that value.
2	Vibration/noise generated from mechanical system	Set the Pr. 820 value a little lower and the Pr. 821 value a little higher.	
		Pr. 820	Decrease the value 10% by 10% until just before vibration/noise is not produced, and set about 0.8 to 0.9 of that value.
		Pr. 821	If an overshoot occurs, double the value until an overshoot does not occur, and set about 0.8 to 0.9 of that value.
3	Slow response	Set the Pr. 820 value a little higher.	
		Pr. 820	When a speed rise is slow, increase the value 5% by 5% until just before vibration/noise is produced, and set about 0.8 to 0.9 of that value.
4	Long return time (response time)	Set the Pr. 821 value a little lower.	
		Decrease the Pr. 821 value by half until just before an overshoot or the unstable phenomenon does not occur, and set about 0.8 to 0.9 of that value.	
5	Overshoot or unstable phenomenon occurs	Set the Pr. 821 value a little higher.	
		Double the Pr. 821 value until just before an overshoot or the unstable phenomenon does not occur, and set about 0.8 to 0.9 of that value.	

**Tab. 5-9:** Adjustment procedures for parameter 820 and 821

**NOTE**

When making manual input gain adjustment, set "0" (without easy gain tuning) (initial value) in Pr. 819 "Easy gain tuning selection".

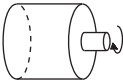
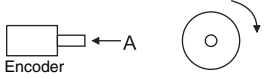
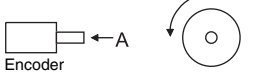
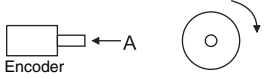
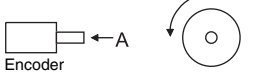
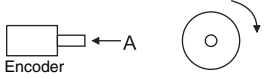
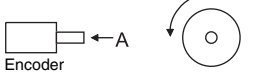

**Troubleshooting**

	Phenomenon	Cause	Countermeasures						
1	Motor does not rotate. (Vector control)	<p>(1) The motor wiring is wrong</p> <p>(2) Encoder specifications (encoder specification selection switch FR-A7AP) are wrong</p> <p>(3) The encoder wiring is wrong.</p> <p>(4) The Pr. 369 "Number of encoder pulses" setting and the number of encoder used are different.</p> <p>(5) Encoder power specifications are wrong. Or, power is not input.</p>	<p>(1) Wiring check Select V/f control (Pr. 800 = 20) and check the rotation direction of the motor. Check the speed monitor output from output terminal CA. For the FR-V5RU, set "340V" for 3.7kW or less and " 320V " for more in Pr. 19 "Base frequency voltage", and set "50Hz" in Pr. 3 "Base frequency".</p> <p>When the forward rotation signal is input, the motor running in the clockwise direction as viewed from the motor shaft is normal. (If it runs in the clockwise direction, the phase sequence of the inverter secondary side wiring is incorrect.)</p>  <p>(2) Check the encoder specifications. Check the encoder specifications selection switch (FR-A7AP) of differential/complimentary.</p> <p>(3) Check that FWD is displayed when running the motor in the clockwise direction from outside during a stop of the inverter with vector control setting. If REV is displayed, the encoder phase sequence is wrong. Perform the correct wiring or match the Pr. 359 "Encoder rotation direction"..</p> <table border="1" data-bbox="1007 1055 1423 1435"> <thead> <tr> <th data-bbox="1007 1055 1139 1115">Pr. 359</th> <th data-bbox="1139 1055 1423 1115">Relationship between the motor and encoder</th> </tr> </thead> <tbody> <tr> <td data-bbox="1007 1115 1139 1267">0</td> <td data-bbox="1139 1115 1423 1267">  <p>Clockwise direction as viewed from A is forward rotation</p> </td> </tr> <tr> <td data-bbox="1007 1267 1139 1435">1 (Initial value)</td> <td data-bbox="1139 1267 1423 1435">  <p>Counter clockwise direction as viewed from A is forward rotation</p> </td> </tr> </tbody> </table> <p>(4) The motor will not run if the parameter setting is smaller than the number of encoder pulses used. Set the Pr. 369 "Number of encoder pulses" correctly.</p> <p>(5) Check the power specifications (5V/12V/15V/24V) of encoder and input the external power supply.</p>	Pr. 359	Relationship between the motor and encoder	0	 <p>Clockwise direction as viewed from A is forward rotation</p>	1 (Initial value)	 <p>Counter clockwise direction as viewed from A is forward rotation</p>
Pr. 359	Relationship between the motor and encoder								
0	 <p>Clockwise direction as viewed from A is forward rotation</p>								
1 (Initial value)	 <p>Counter clockwise direction as viewed from A is forward rotation</p>								

**Tab. 5-10: Troubleshooting (1)**

	Phenomenon	Cause	Countermeasures
2	Motor does not run at correct speed. (Speed command does not match actual speed)	<p>(1) The speed command from the command device is incorrect. The speed command is compounded with noise.</p> <p>(2) The speed command value does not match the inverter-recognized value.</p> <p>(3) The number of encoder pulses setting is incorrect.</p>	<p>(1) Check that a correct speed command comes from the command device. Decrease Pr. 72 "PWM frequency selection".</p> <p>(2) Readjust speed command bias/gain Pr. 125, Pr. 126, C2 to C7 and C12 to C15.</p> <p>(3) Check the setting of Pr. 369 "Number of encoder pulses". (vector control)</p>
3	Speed does not rise to the speed command.	<p>(1) Insufficient torque. Torque limit is actuated.</p> <p>(2) Only P (proportional) control is selected.</p>	<p>(1)-1 Increase the torque limit value. (Refer to torque limit of speed control in section 6.3.3.)</p> <p>(1)-2 Insufficient capacity</p> <p>(2) When the load is heavy, speed deviation will occur under P (proportional) control. Select PI control.</p>
4	Motor speed is unstable.	<p>(1) The speed command varies.</p> <p>(2) Insufficient torque.</p> <p>(3) The speed control gains do not match the machine. (machine resonance)</p>	<p>(1)-1 Check that a correct speed command comes from the command device. (Take measures against noises.)</p> <p>(1)-2 Decrease Pr. 72 "PWM frequency selection".</p> <p>(1)-3 Increase Pr. 822 "Speed setting filter 1". (Refer to section 6.20.4.)</p> <p>(2) Increase the torque limit value. (Refer to torque limit of speed control in section 6.3.3.)</p> <p>(3)-1 Perform easy gain tuning. (Refer to section 5.1.11).</p> <p>(3)-2 Adjust Pr. 820, Pr. 821. (Refer to page 5-35).</p> <p>(3)-3 Perform speed feed forward/model adaptive speed control.</p>
5	Motor or machine hunts (vibration/noise is produced).	<p>(1) The speed control gain is high.</p> <p>(2) The torque control gain is high.</p> <p>(3) The motor wiring is wrong.</p>	<p>(1)-1 Perform easy gain tuning. (Refer to section 5.1.11).</p> <p>(1)-2 Decrease Pr. 820 and increase Pr. 821.</p> <p>(1)-3 Perform speed feed forward control and model adaptive speed control.</p> <p>(2) Decrease the Pr. 824 value. (Refer to section 6.4.5.)</p> <p>(3) Check the wiring.</p>

**Tab. 5-10: Troubleshooting (2)**

	Phenomenon	Cause	Countermeasures
6	Acceleration/deceleration time does not match the setting.	(1) Insufficient torque.  (2) Large load inertia.	(1)-1 Increase the torque limit value. (Refer to torque limit of speed control in section 6.3.3.) (1)-2 Perform speed feed forward control. (2) Set the acceleration/deceleration time that meets the load.
7	Machine operation is unstable	(1) The speed control gains do not match the machine.  (2) Slow response because of improper acceleration/deceleration time of the inverter.	(1)-1 Perform easy gain tuning. (Refer to section 5.1.11). (1)-2 Adjust Pr. 820, Pr. 821. (Refer to page 5-35). (1)-3 Perform speed feed forward control and model adaptive speed control. (2) Change the acceleration/deceleration time to an optimum value.
8	Speed fluctuates at low speed.	(1) Adverse effect of high carrier frequency. (2) Low speed control gain.	(1) Decrease Pr. 72 "PWM frequency selection". (2) Increase Pr. 820 "Speed control P gain 1".

**Tab. 5-10: Troubleshooting (3)**

## 5.2 PU operation mode

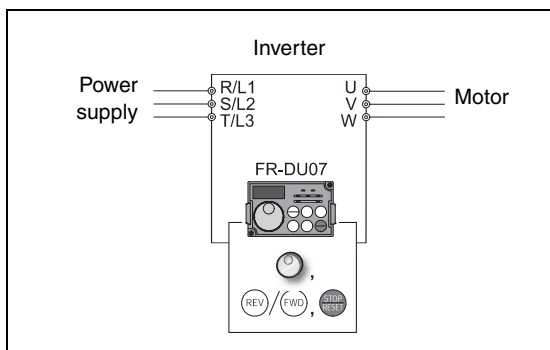

**Fig. 5-16:**  
PU operation mode

1001069E

From where is the frequency command given?

- Operation at the frequency set in the frequency setting mode of the operation panel. (Refer to section 5.2.1.)
- Operation using the digital dial as the volume. (Refer to section 5.2.2.)
- Change of frequency with ON/OFF switches connected to terminals. (Refer to section 5.2.3.)
- Frequency setting with a voltage output device. (Refer to section 5.2.4.)
- Frequency setting with a current output device. (Refer to section 5.2.5.)

## 5.2.1 Set the set frequency to operate

### Example ▾ Performing operation at 30Hz

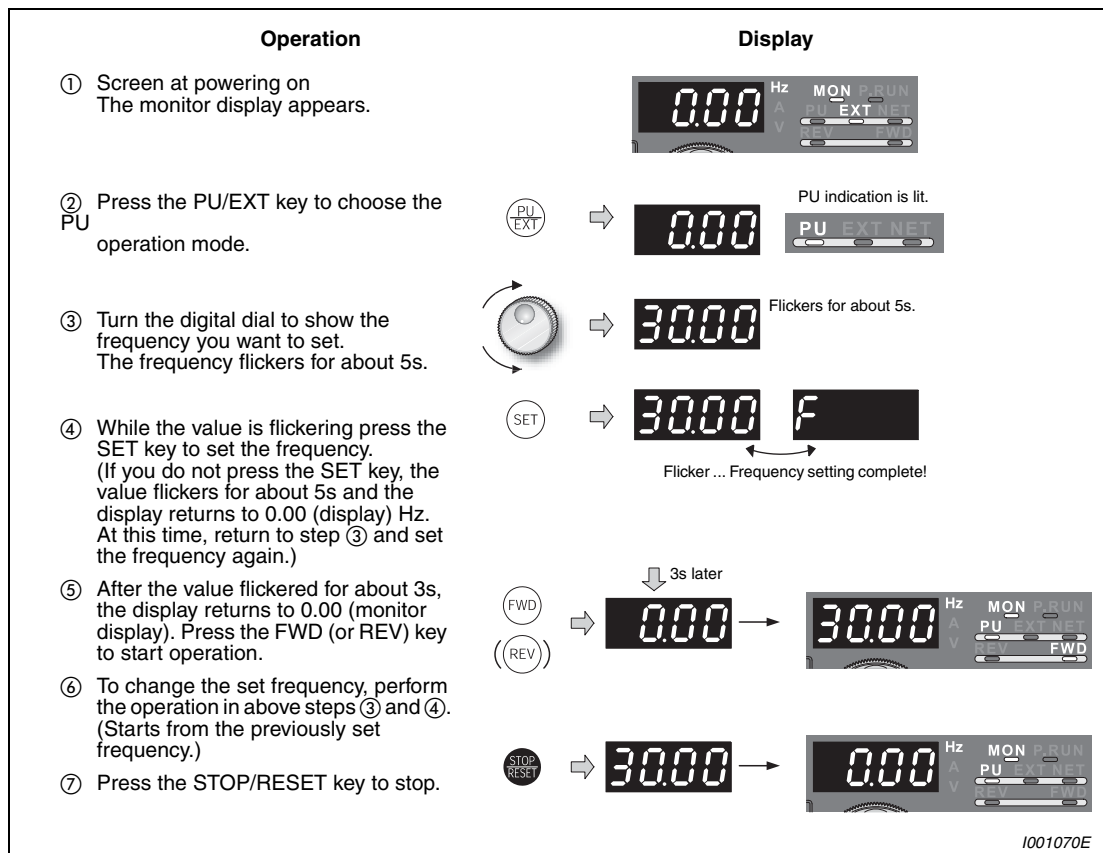

**Fig. 5-17:** Frequency setting with the digital dial

#### Possible faults:

- Operation cannot be performed at the set frequency.
  - Did you press the SET key within 5s after turning the digital dial?
- The frequency does not change by turning the digital dial.
  - Check to see if the operation mode selected is the external operation mode. (Press the PU/EXT key to change to the PU operation mode.)
- Operation does not change to the PU operation mode.
  - Check that "0" (initial value) is set in Pr. 79 Operation mode selection.
  - Check that the start command is not on.

Change the acceleration time using Pr. 7 (refer to section 5.1.5) and the deceleration time using Pr. 8 (refer to section 5.1.5).

The maximum output frequency is set in Pr. 1. (Refer to section 5.1.4).

#### NOTES

Press the digital dial to show the set frequency.

The digital dial can also be used like a potentiometer to perform operation. (Refer to section 5.2.2.)



### 5.2.2 Use the digital dial like a potentiometer to perform operation

- Set "1" (setting dial potentiometer mode) in Pr. 161 "Frequency setting/key lock operation selection".

**Example** ▾

Change the frequency from 0Hz to 50Hz during operation.

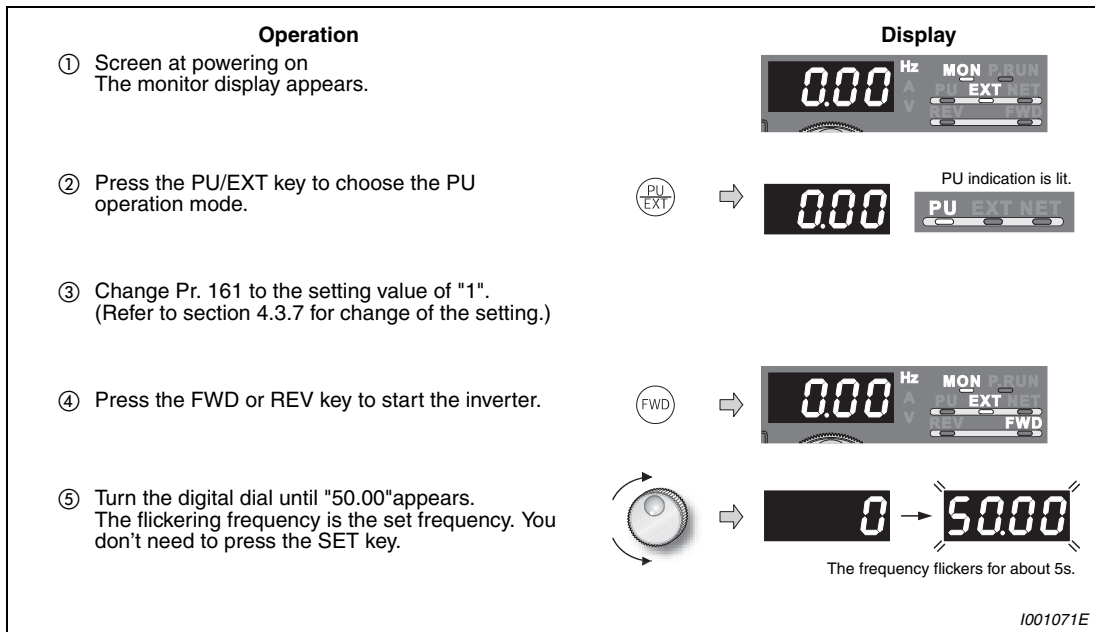

**Fig. 5-18:** Use the digital dial like a potentiometer to perform operation

**NOTES**

- ▮ If flickering "50.00" turns to "0.0", the Pr. 161 "Frequency setting/key lock operation selection" setting may not be "1".
- ▮ Independently of whether the inverter is running or at a stop, the frequency can be set by merely turning the digital dial.



### 5.2.3 Use switches to give the frequency command (multi-speed setting)

- Pr. 79 "Operation mode selection" must be set to "4" (external/PU combined operation mode 2).
- Use the FWD or REV key to give a start command.
- The initial values of the terminals RH, RM, RL are 50Hz, 30Hz, and 10Hz. (Refer to section 5.3.2 to change frequencies using Pr. 4, Pr. 5 and Pr. 6.)
- Operation at 15-speed can be performed by turning on two (or three) terminals simultaneously.

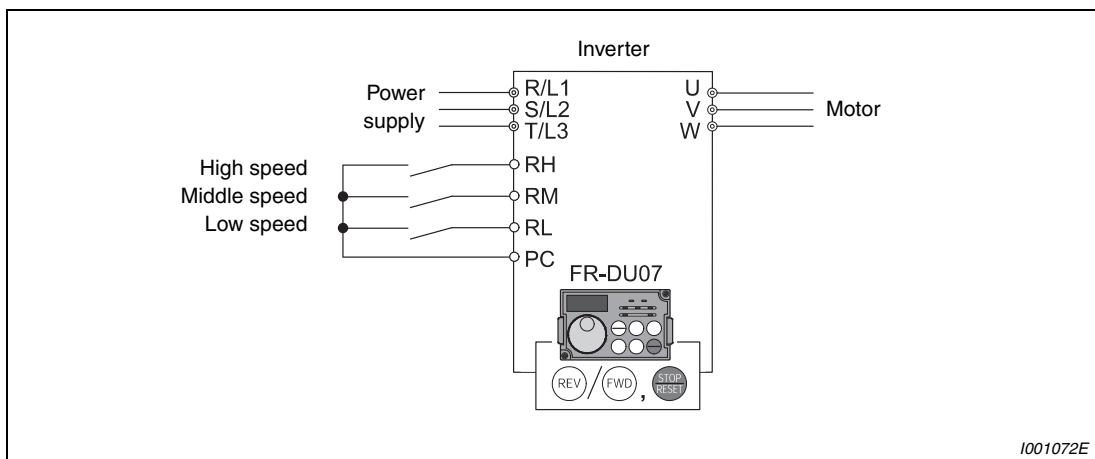

Fig. 5-19: Use switches to give the frequency command

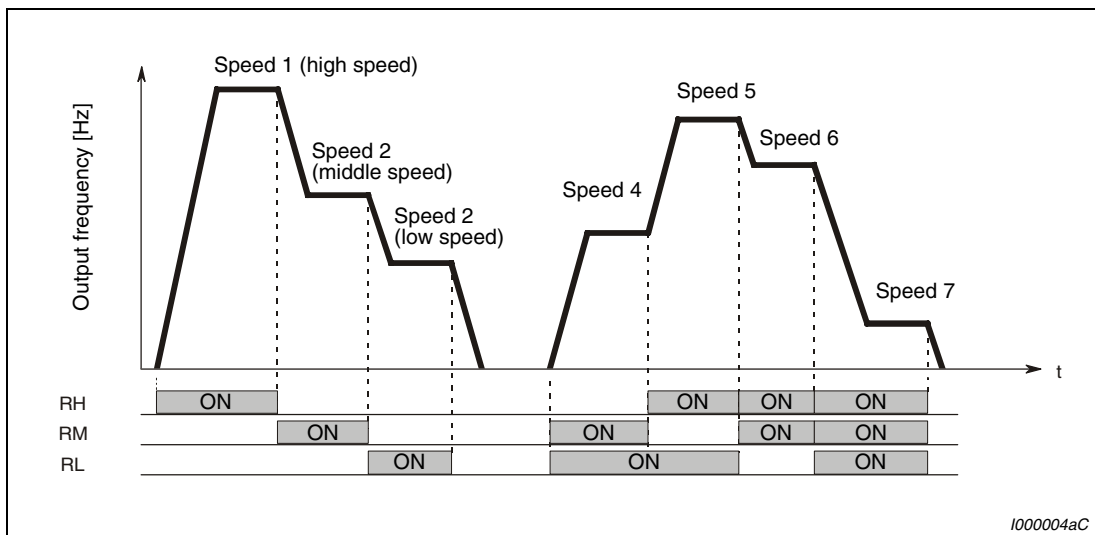
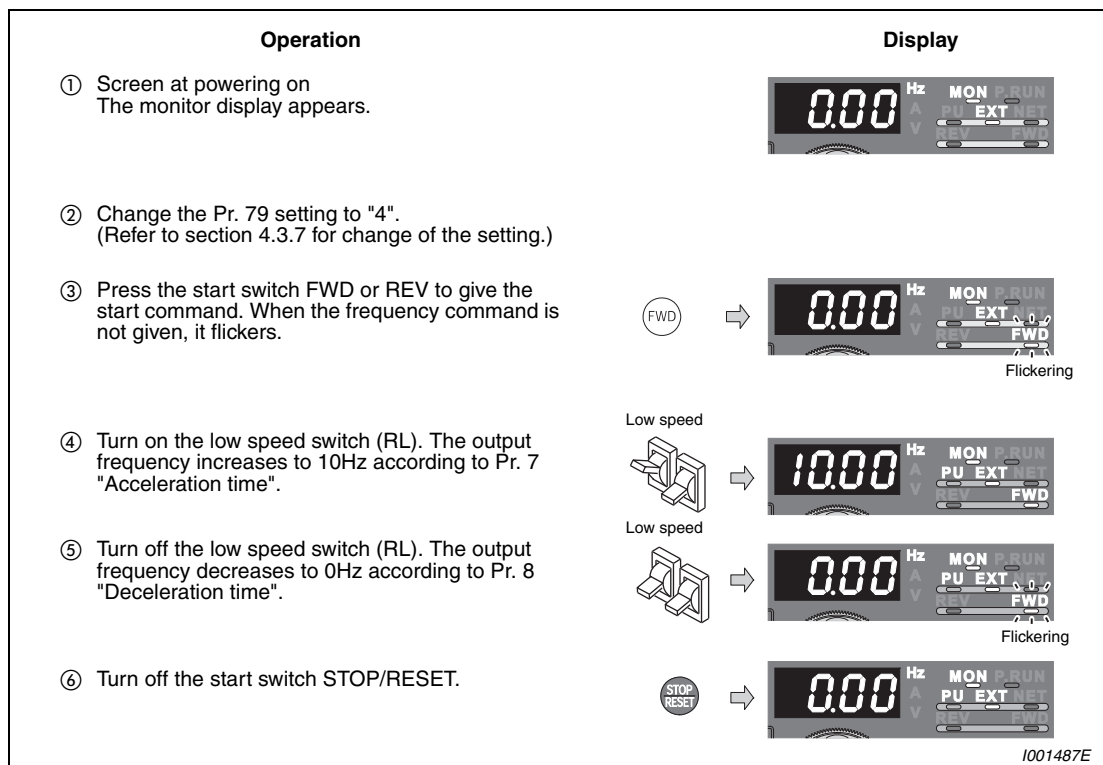

Fig. 5-20: Multi-speed selection by external terminals



**Fig. 5-21: Operate the inverter by using multi-speed setting**

**Possible faults:**

- 50Hz for the RH, 30Hz for the RL and 10Hz for the RL are not output when they are turned on.
  - Check for the setting of Pr. 4, Pr. 5, and Pr. 6 once again.
  - Check for the setting of Pr. 1 "Maximum frequency" and Pr. 2 "Minimum frequency" once again. (Refer to section 5.1.4.)
  - Check that Pr. 180 "RL terminal function selection" = "0", Pr. 181 "RM terminal function selection" = "2", Pr.182 "RH terminal function selection" and Pr. 59 "Remote function selection" = "0" (all are initial values).
- FWD (or REV) lamp is not lit.
  - Check that wiring is correct. Check the wiring once again.
  - Check for the Pr. 79 setting once again. (Pr. 79 must be set to "4".) (Refer to section 5.1.6.)

**NOTE**

Refer to section 5.3.2 to change the running frequency at each terminal in Pr. 4 "Multi-speed setting (highspeed)", Pr. 5 "Multi-speed setting (middle speed)", and Pr. 6 "Multi-speed setting (low speed)".



## 5.2.4 Perform frequency setting by analog voltage input

- Pr. 79 "Operation mode selection" must be set to "4" (external/PU combined operation mode 2).
- Use the FWD or REV key to give a start command.

The frequency setting potentiometer is supplied with 5V of power from the inverter (terminal 10).

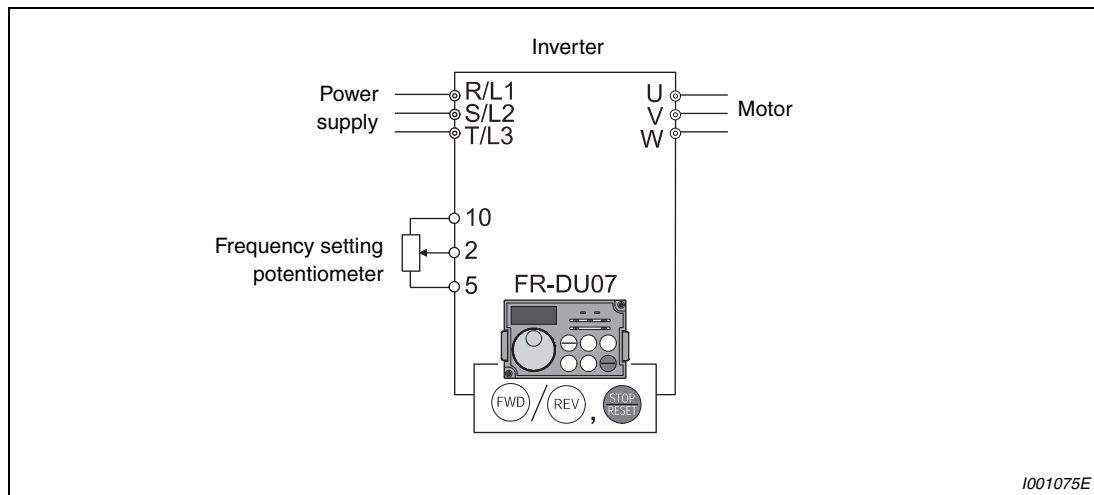

**Fig. 5-22:** Frequency setting by analog voltage input

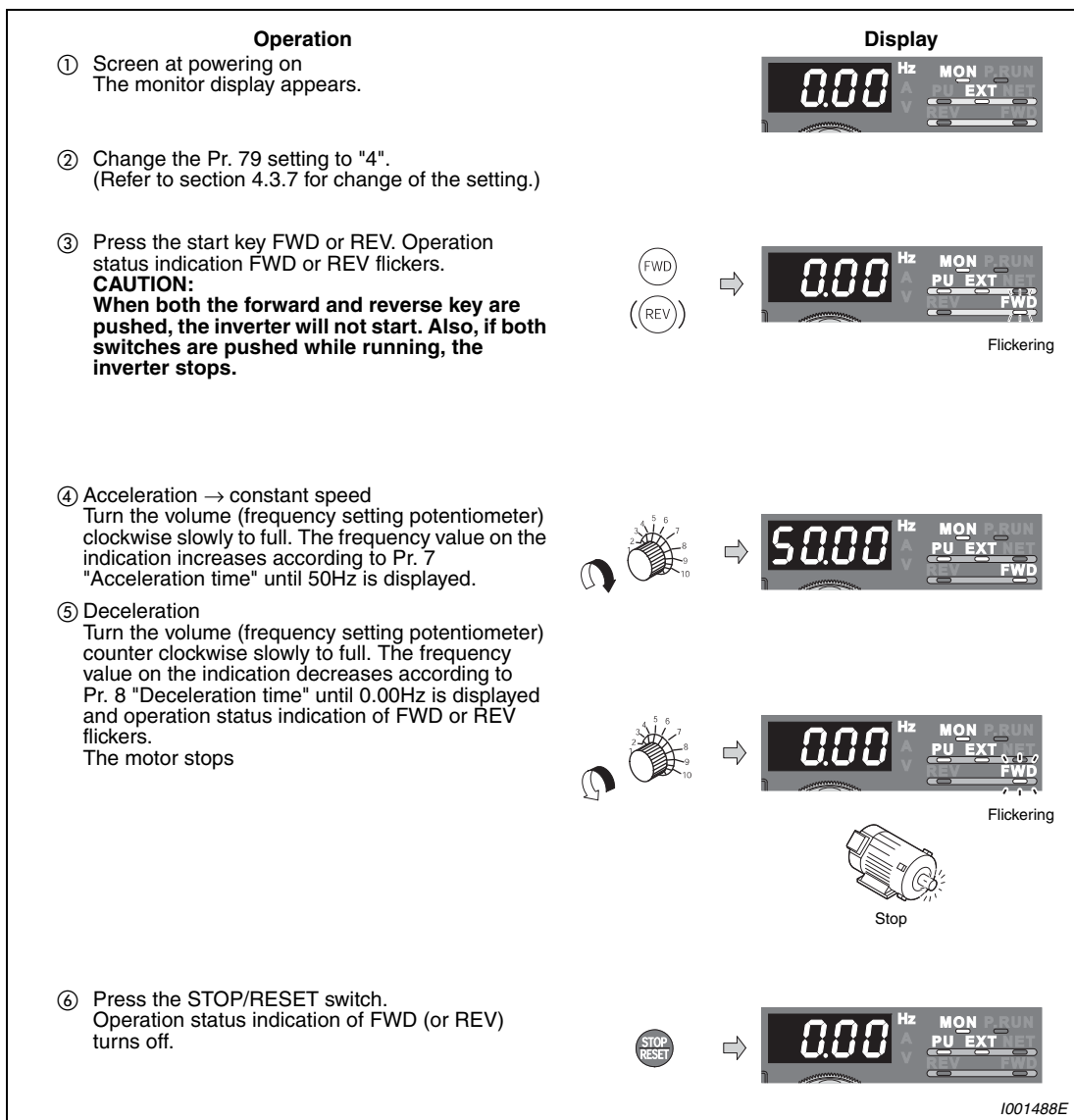

Fig. 5-23: Operate the inverter by using the analog voltage input

**NOTES**

Change the frequency (50Hz) of the maximum value of potentiometer (at 5V, initial value) by adjusting the frequency in Pr. 125 "Terminal 2 frequency setting gain frequency". (Refer to section 5.3.4.).

Change the frequency (0Hz) of the minimum value of potentiometer (at 0V, initial value) by adjusting the frequency in calibration parameter C2 "Terminal 2 frequency setting bias frequency". (Refer to section 6.20.5.)

### 5.2.5 Perform frequency setting by analog current input

- Pr. 79 "Operation mode selection" must be set to "4" (external/PU combined operation mode 2).
- Use the FWD or REV key to give a start command.

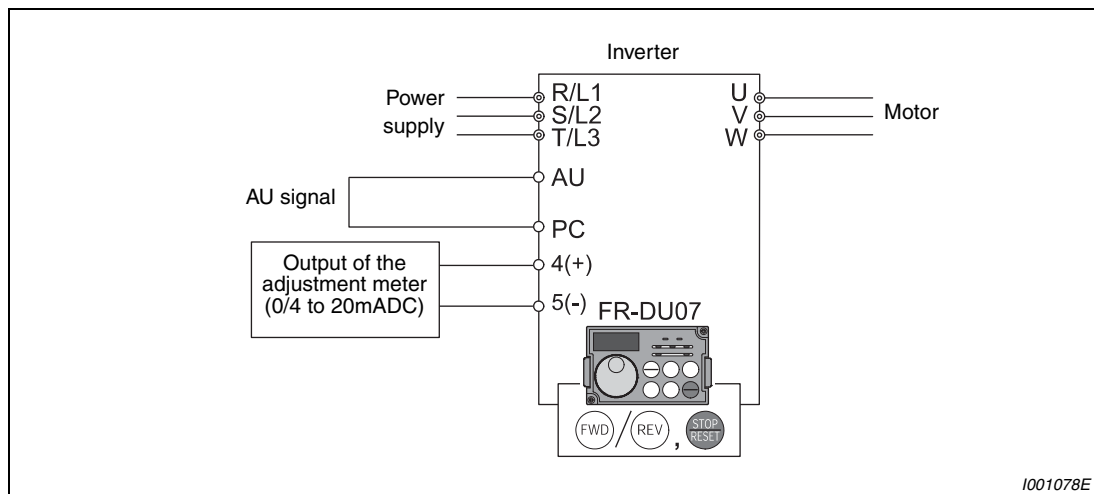

**Fig. 5-24:** Frequency setting by analog current input

#### NOTE

Turn the AU signal on to activate the analog current input (0/4 to 20mA). Use a jumper or the like as shown in Fig. 5-24.

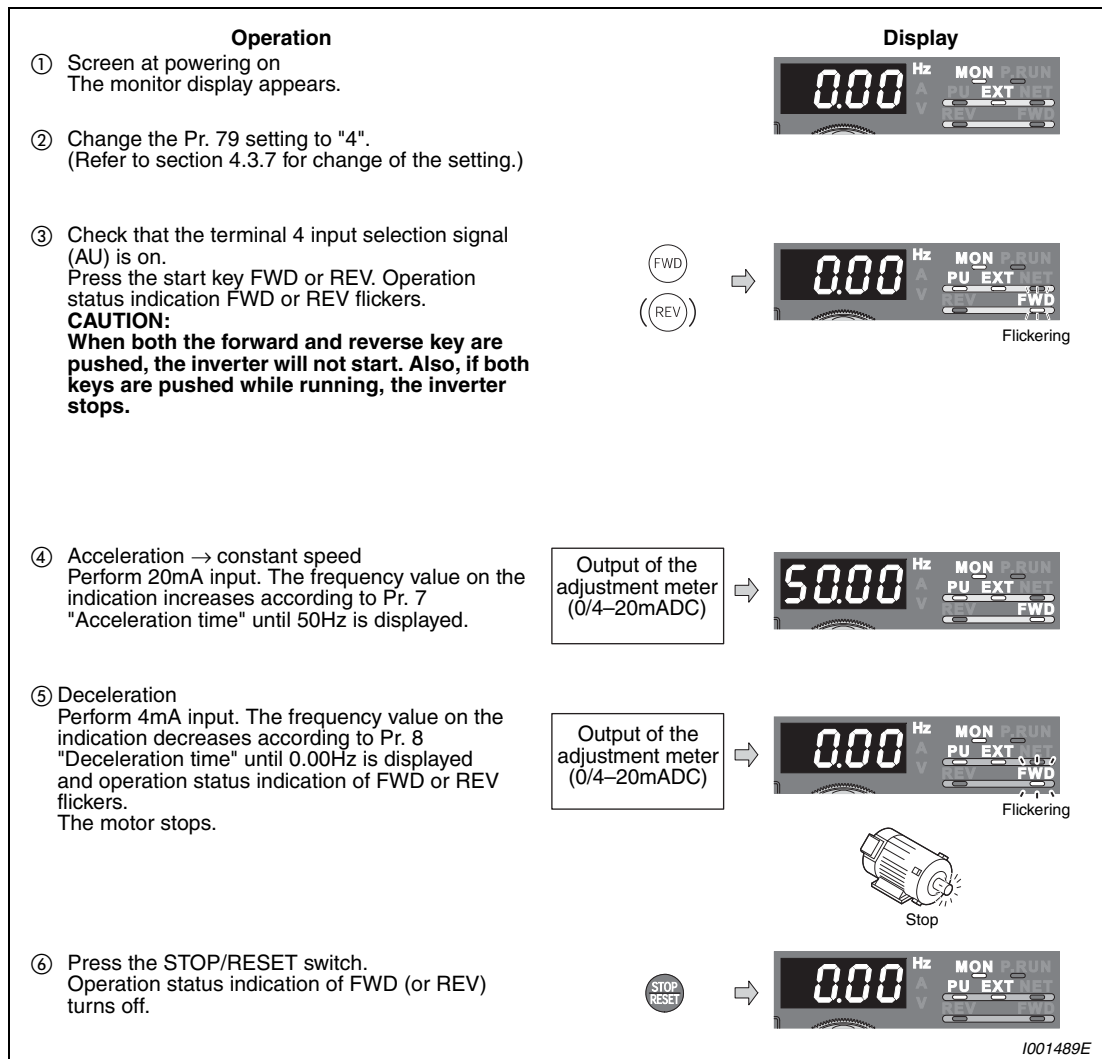

**Fig. 5-25: Operate the inverter by using the analog current input**

**NOTES**

- Pr. 184 "AU terminal function selection" must be set to "4" (AU signal) (initial value). (Refer to section 6.14.1.)
- Change the frequency (50Hz) at the maximum value of potentiometer (at 20mA) by adjusting the frequency in Pr. 126 "Terminal 4 frequency setting gain frequency". (Refer to section 5.3.6.)
- Change the frequency (0Hz) at the minimum value of potentiometer (at 4mA) by adjusting the frequency in calibration parameter C5 "Terminal 4 frequency setting bias frequency". (Refer to section 6.20.5.)

## 5.3 External operation

From where is the frequency command given?

- Operation at the frequency set in the frequency setting mode of the operation panel. (Refer to section 5.3.1.)
- Give a frequency command by switch (multi-speed setting). (Refer to section 5.3.2.)
- Perform frequency setting by a voltage output device. (Refer to section 5.3.3.)
- Perform frequency setting by a current output device. (Refer to section 5.3.4.)

### 5.3.1 Use the set frequency set by the operation panel (Pr. 79 = 3)

- Set "3" in Pr. 79 (External/PU combined operation mode 1).
- Switch terminal STF (STR)-PC on to give a start command.
- Refer to section 5.2.1 for the set frequency by the operation panel.

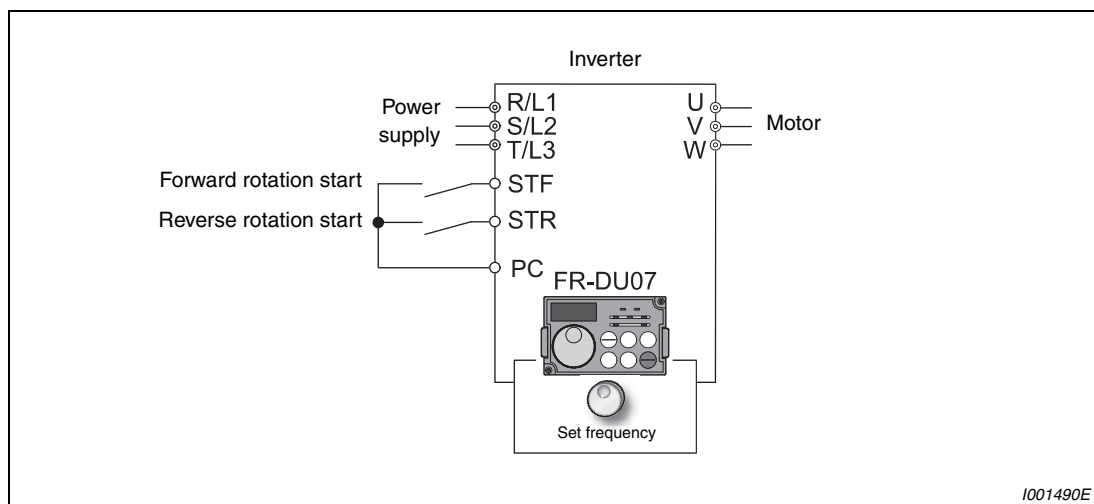

**Fig. 5-26:** External operation

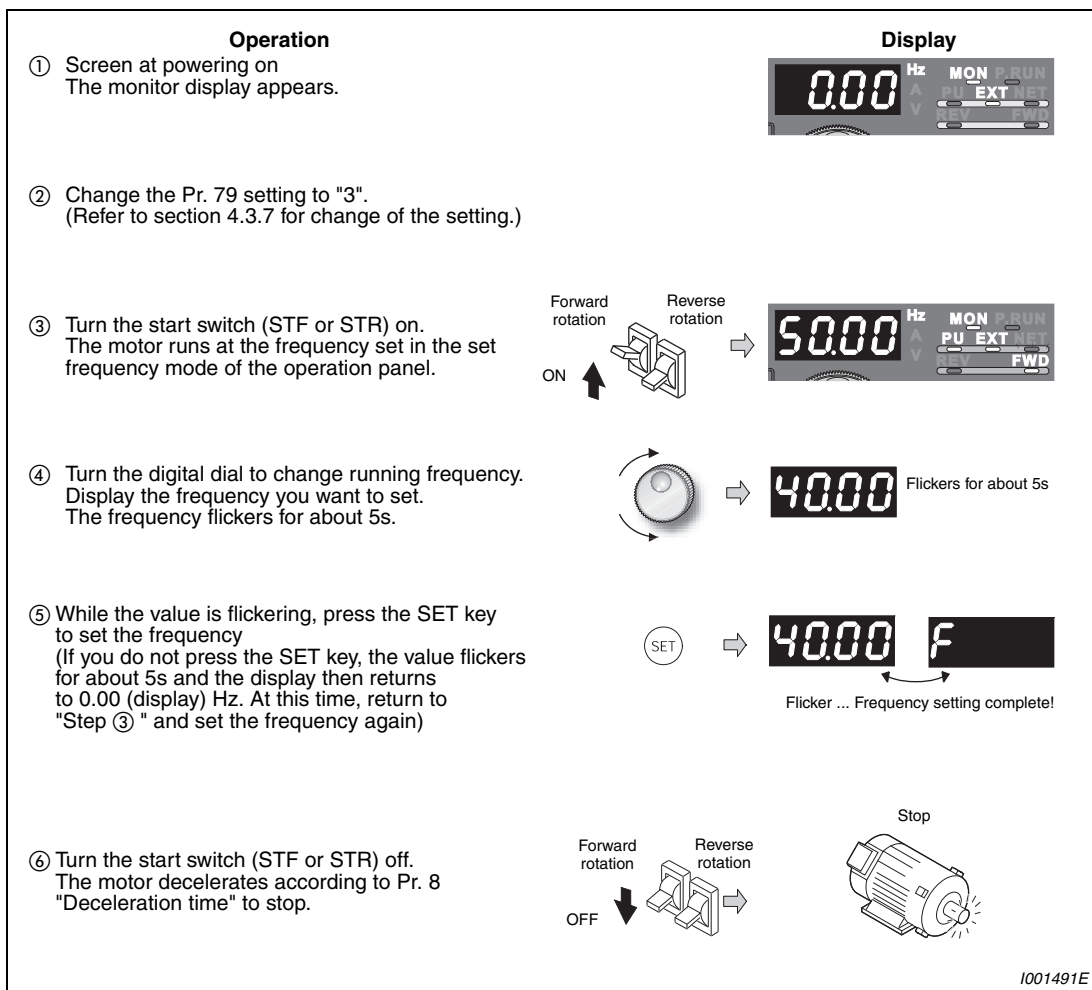



Fig. 5-27: Operate the inverter by using external signals

**NOTES**

Pr. 178 "STF terminal function selection" must be set to "60" (or Pr. 179 "STR terminal function selection" must be set to "61"). (All are initial values.)

When Pr. 79 "Operation mode selection" is set to "3", multi-speed operation (Refer to section 5.3.2) is also made valid.

**Possible faults:**

- When the inverter is stopped by the STOP/RESET key of the operation panel (FR-DU07),  and  are displayed alternately.
  - Turn the start switch (STF or STR) off.
  - The display can be reset by PU/EXT.

### 5.3.2 Use switches to give a start command and a frequency command (multi-speed setting) (Pr. 4 to Pr. 6)

- Start command by terminal STF (STR)-PC.
- Frequency command by terminal RH, RM, RL and STR-PC.
- "EXT" must be lit. (When "PU" is lit, switch it to "EXT" with the PU/EXT key.)
- The initial values of the terminals RH, RM, RL are 50Hz, 30Hz, and 10Hz. (Use Pr. 4, Pr. 5 and Pr. 6 to change.)
- Operation at 15-speed can be performed by turning two (or three) terminals simultaneously. (Refer to section 6.10.1.)

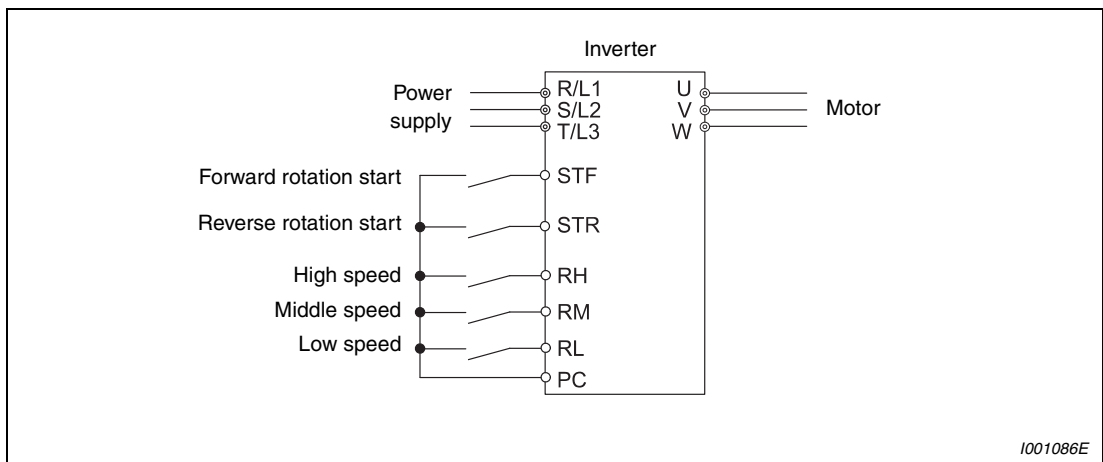

**Fig. 5-28:** Frequency and start command by switches

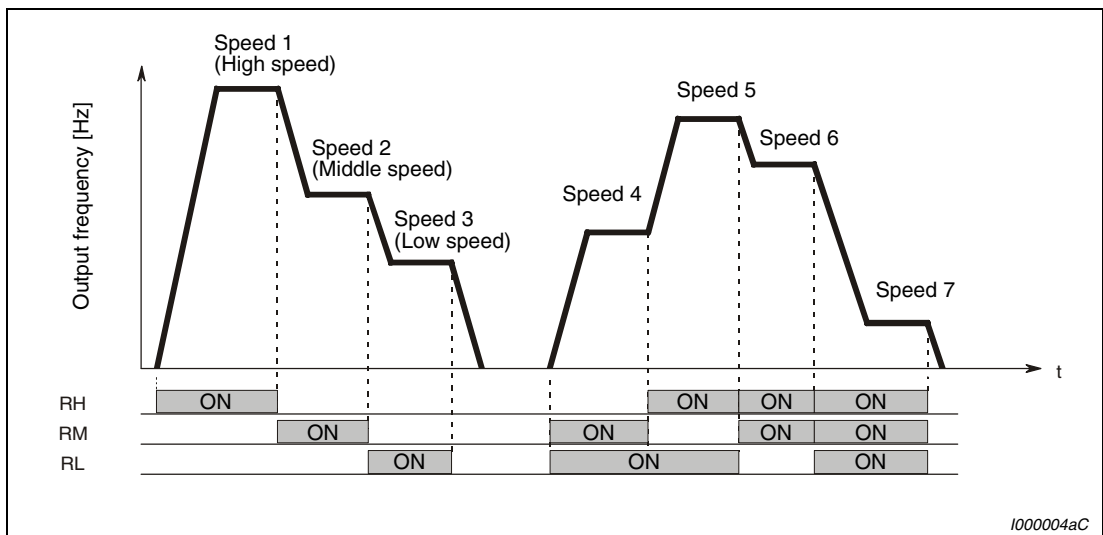

**Fig. 5-29:** Multi-speed setting in dependence on the terminals

**Example** ▽

Set "40Hz" in Pr. 4 "Multi-speed setting (high speed)" and turn on terminals RH and STF (STR)-SD to operate.

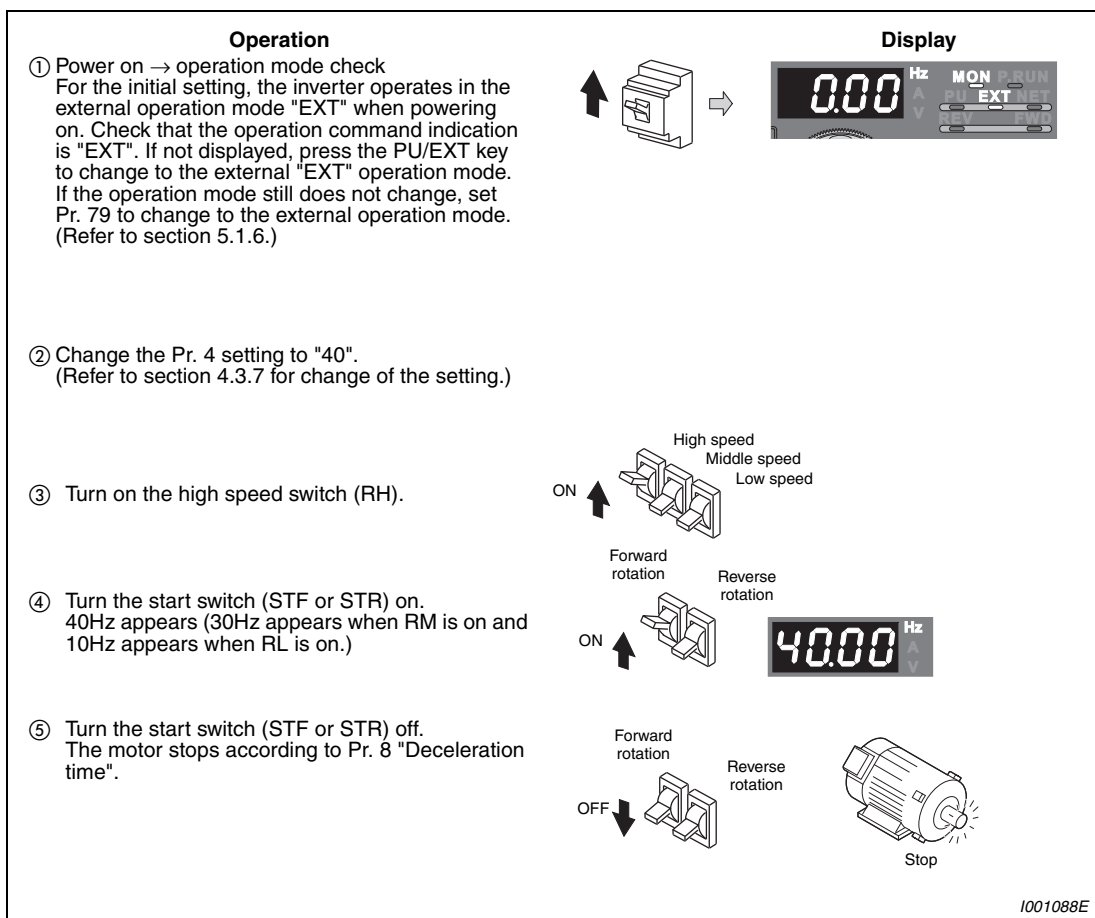

**Fig. 5-30:** Operate the inverter by using external signals





**Possible faults:**

- The EXT lamp is not lit even when the PU/EXT key is pressed.
  - Switchover of the operation mode with is valid when Pr. 79 = 0 (initial value).
- 40Hz, 30Hz and 10Hz are not output from RH, RM and RL respectively when they are turned on.
  - Check for the setting of Pr. 4, Pr. 5, and Pr. 6 once again.
  - Check for the setting of Pr. 1 "Maximum frequency" and Pr. 2 "Minimum frequency" once again. (Refer to section 5.1.4.)
  - Check for the Pr. 79 setting once again. (Pr. 79 must be set to "0" or "2".) (Refer to section 5.1.6.)
  - Check that Pr. 180 "RL terminal function selection" = "0", Pr. 181 "RM terminal function selection" = "1", Pr. 182 "RH terminal function selection" = "2" and Pr. 59 "Remote function selection" = "0". (All are initial values.)
- The FWD or REV lamp is not lit.
  - Check that wiring is correct. Check it again.
  - Check that "60" is set in Pr. 178 "STF terminal function selection" (or "61" is set in Pr. 179 "STR terminal function selection"). (All are initial values.)
- How is the frequency setting from 4 to 7 speed?
  - The setting differs according to Pr. 24 to Pr. 27 (multi-speed setting). (Refer to section 6.10.1).
- How is a multi-speed operation higher than 8 speed performed?
  - Use the REX signal to perform the operation. (Refer to section 6.10.1).

**NOTE**

External operation is fixed by setting "2" (external operation mode) in Pr. 79 "Operation mode selection" when you do not want to take time pressing the PU/EXT key or when you want to use the current start command and frequency command.

### 5.3.3 Perform frequency setting by analog voltage input

The frequency setting potentiometer is supplied with 5V of power from the inverter (terminal 10).

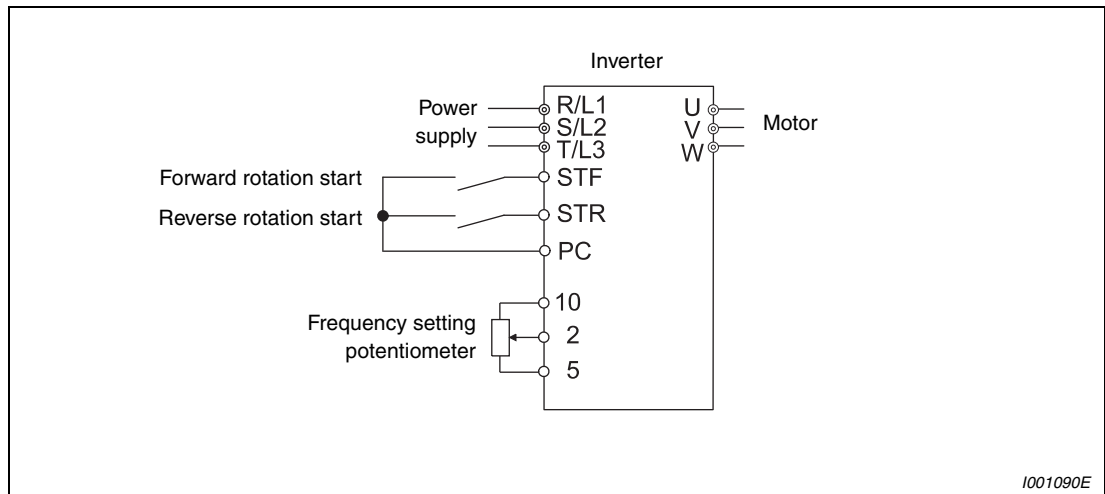

**Fig. 5-31:** Frequency setting by analog voltage input

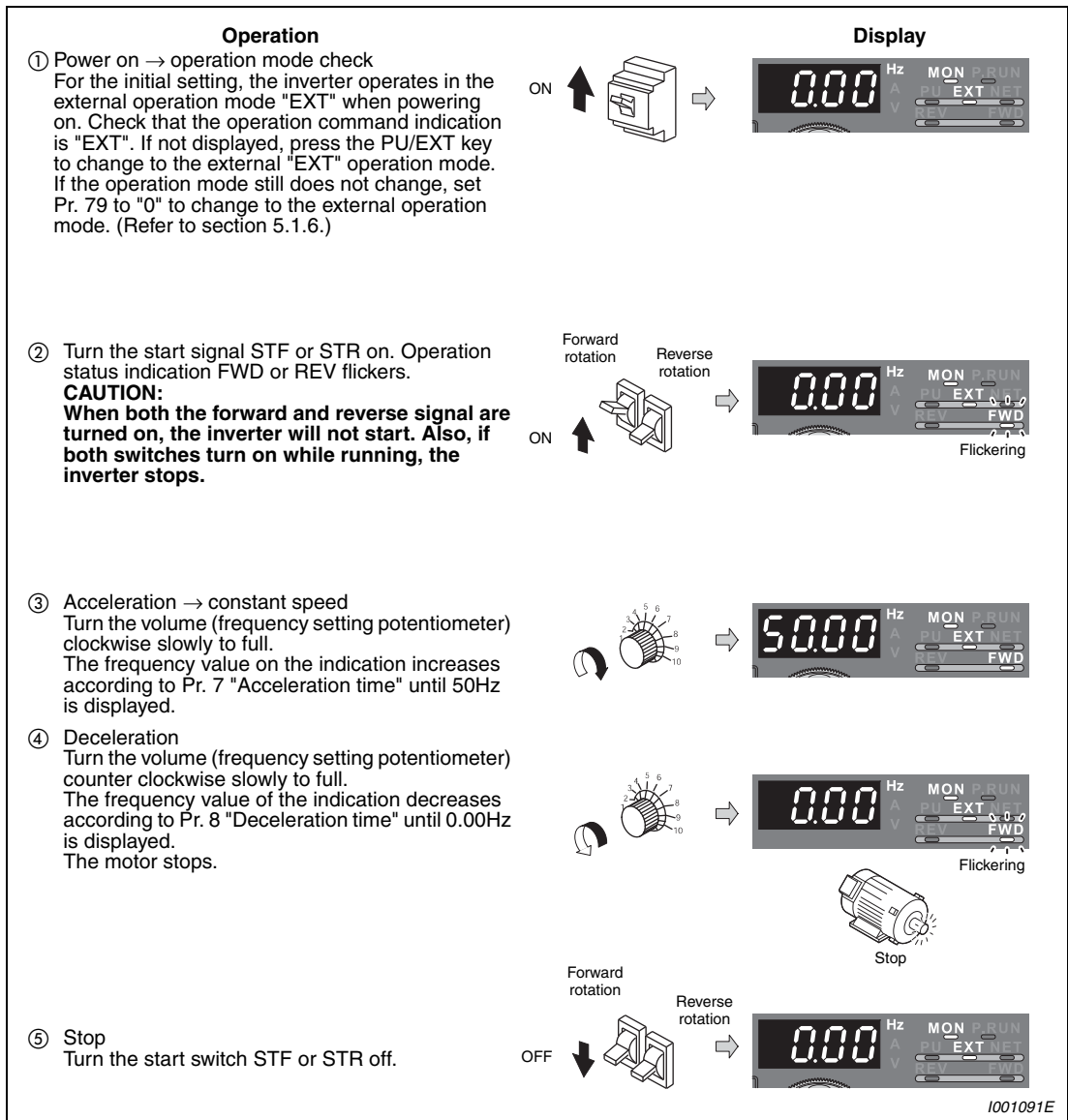

Fig. 5-32: Operate the inverter by using the analog voltage input

**NOTES**

When you want to operate in the external operation mode always at powering on or when you want to save the trouble of input, set "2" (external operation mode) in Pr. 79 "Operation mode selection" to choose external operation mode always.

Pr. 178 "STF terminal function selection" must be set to "60" (or Pr. 179 "STR terminal function selection" must be set to "61"). (All are initial values.)

**Possible faults:**

- The motor will not rotate.
  - Check that the EXT lamp is lit. The external operation mode is valid when Pr. 79 = 0 (initial value) or "2". Use the PU/EXT key to change into the external operation mode.
  - Check that wiring is correct. Check once again.

**NOTES**









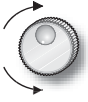

Change the frequency (0Hz) of the minimum value of potentiometer (at 0V, initial value) by adjusting the frequency in calibration parameter C2 "Terminal 2 frequency setting bias frequency". (Refer to section 6.20.5.)

When you want to compensate frequency setting, use terminal 1.

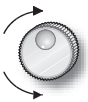
### 5.3.4 Change the frequency (50Hz) of the maximum value of potentiometer (at 5V)

**Example** ▽

The frequency of the maximum analog voltage of the potentiometer (at 5V) has to be changed from the initial setting of 50Hz to 40 Hz. Set 40Hz in Pr. 125.

Operation	Display
① Turn the digital dial until P.125 (Pr. 125) appears.	 → 
② Press the SET key to show the currently set value. The initial value "50.00" (50.00Hz) appears.	 → 
③ Turn the digital dial to change the set value to "40.00" (40.00Hz).	 → 
④ Press the SET key to set.	 → 
⑤ Press the MODE key twice to choose monitor/frequency monitor.	 → 
⑥ Turn the start switch (STF or STR) on and turn the volume (frequency setting potentiometer) clockwise to full slowly. (Refer to Fig. 5-32, step ② to ⑤).	

1001092E

**Fig. 5-33:** Change the frequency of the maximum analog value



**NOTES**

Set the frequency at 0V using calibration parameter C2.

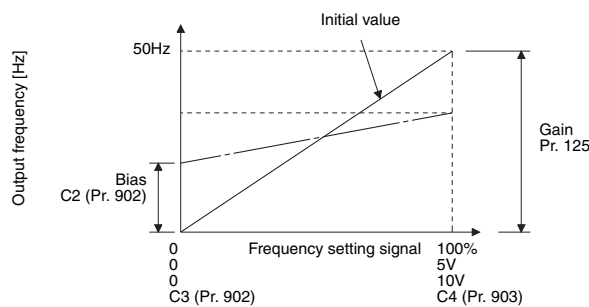

As other adjustment methods of frequency setting voltage gain, there are methods to adjust with a voltage applied to across terminals 2-5 and adjust at any point without a voltage applied. (Refer to section 6.20.5 for the setting method of calibration parameter C4.)

### 5.3.5 Perform frequency setting by analog current input

- Switch terminal STF (STR)-PC on to give a start command.
- Turn the AU signal on.
- Pr. 79 "Operation mode selection" must be set to "2" (external operation mode).

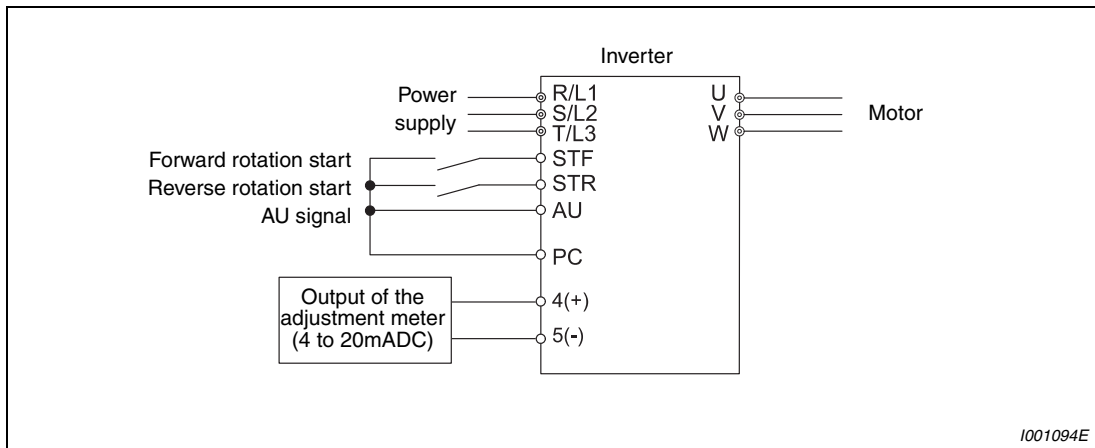

**Fig. 5-34:** Frequency setting by analog current input

**NOTE**

Turn the AU signal on to activate the analog current input (0/4 to 20mA). Use a jumper or the like as shown in Fig. 5-34.

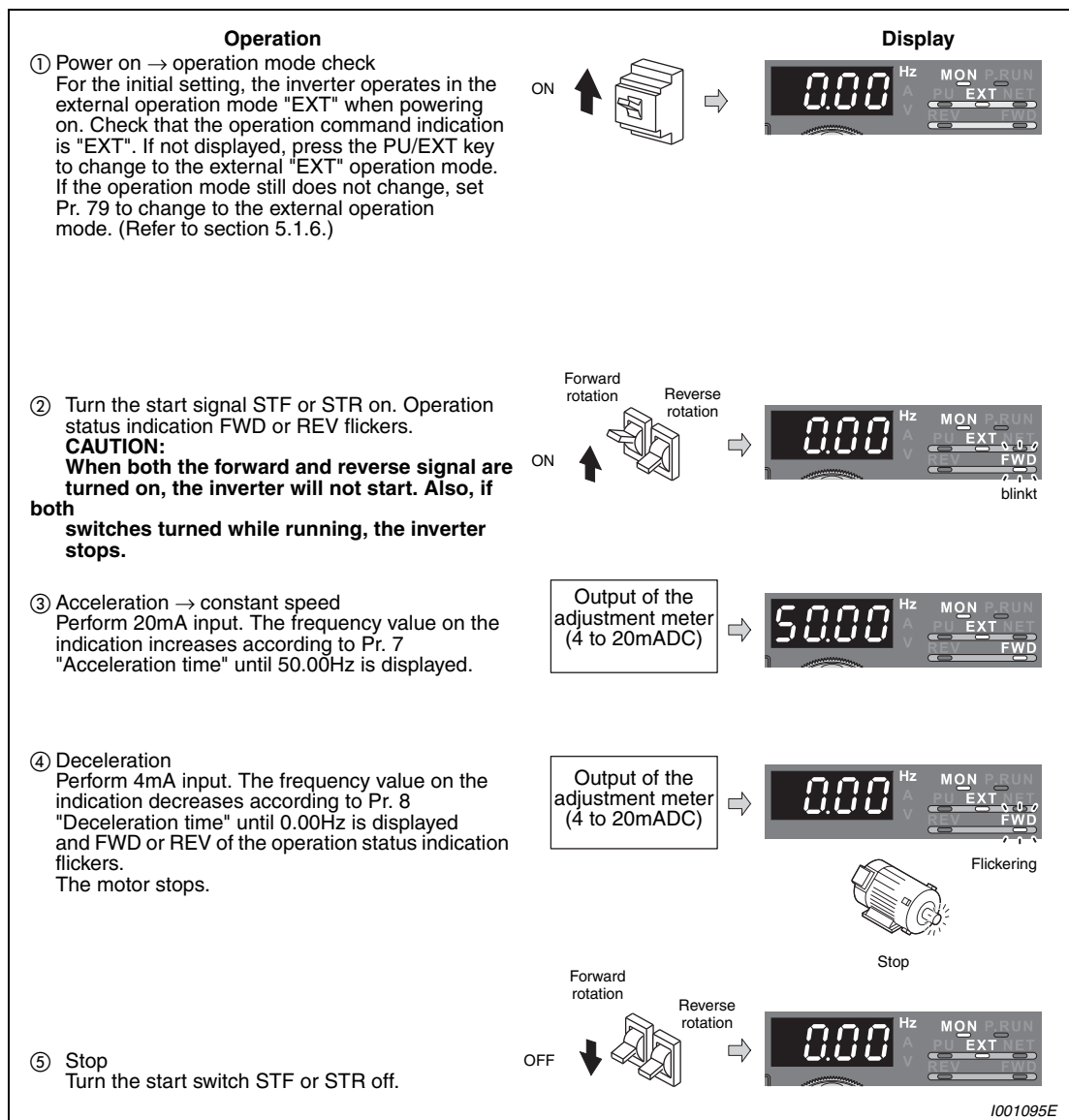

**Fig. 5-35:** Operate the inverter by using the analog current input

**NOTE**

Pr. 184 "AU terminal function selection" must be set to "4" (AU signal) (initial value).

**Possible faults:**

- The motor will not rotate.
  - Check that the EXT lamp is lit. The external operation mode is valid when Pr. 79 = 0 (initial value) or "2". Use the PU/EXT key to change into the external operation mode.
  - The AU signal must be turned on.
  - Check that wiring is correct. Check once again.









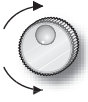

**NOTE**

Change the frequency (0Hz) of the minimum value of potentiometer (at 4mA, initial value) by adjusting the frequency in calibration parameter C5 "Terminal 4 frequency setting bias frequency". (Refer to section 6.20.5.)

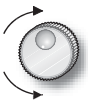
### 5.3.6 Change the frequency (50Hz) of the maximum value of potentiometer (at 20mA)

**Example** ▽

The frequency of the maximum analog current of the potentiometer (at 20mA) has to be changed from the initial setting of 50Hz to 40 Hz. Set 40Hz in Pr. 126.

Operation	Display
① Turn the digital dial until P.126 (Pr. 126) appears.	 → 
② Press the SET key to show the currently set value. The initial value "50.00" (50.00Hz) appears.	 → 
③ Turn the digital dial to change the set value to "40.00" (40.00Hz).	 → 
④ Press the SET key to set.	 → 
⑤ Press the MODE key twice to choose monitor/frequency monitor.	 → 
⑥ Turn the start switch STF or STR on to allow 20mA current to flow. (Refer to Fig. 5-35, step ② to ⑤.)	

I001096E

**Fig. 5-36:** Change the frequency of the maximum analog value



**NOTES**

Set the frequency at 4mA using calibration parameter C5.

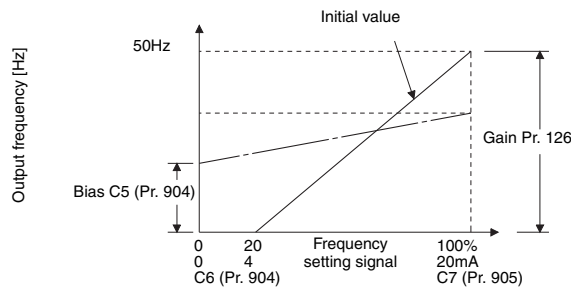

As other adjustment methods of frequency setting current gain, there are methods to adjust with a current flowing in the terminals 4-5 and adjust at any point without a current flowing. (Refer to section 6.20.5 for the setting method of calibration parameter C7.)







# 6 Parameter

## 6.1 Parameter overview



For simple variable-speed operation of the inverter, the initial setting of the parameters may be used as they are. Set the necessary parameters to meet the load and operational specifications. Parameter setting, change and check can be made from the operation panel FR-DU07.

⊙ indicates simple mode parameters. (initially set to extended mode)

The abbreviations in the explanations below are as follows:

-  V/f control
-  Advanced magnetic flux vector control
-  Real sensorless vector control
-  Vector control

Parameters without any indication are valid for all control. The half-tone screened parameters allow its setting to be changed during operation even if "0" (initial value) is set in Pr. 77 "Parameter write selection".

Function	Parameter	Name	Increments	Initial Value	Setting Range	Description	Parameter copy	Parameter clear	All parameter clear	Refer to page												
							✓: enabled —: disabled															
Manual torque boost 	0 ⊙	Torque boost	0.1%	6/4/3/ 2/1 *	0–30%	Set the output voltage at 0Hz as % * Initial values differ according to the inverter capacity:	✓	✓	✓	6-168												
						<table border="1"> <thead> <tr> <th>Inverter capacity</th> <th>Initial value</th> </tr> </thead> <tbody> <tr> <td>00023/00038</td> <td>6%</td> </tr> <tr> <td>00052–00126</td> <td>4%</td> </tr> <tr> <td>00170/00250</td> <td>3%</td> </tr> <tr> <td>00310–01800</td> <td>2%</td> </tr> <tr> <td>02160 or more</td> <td>1%</td> </tr> </tbody> </table>					Inverter capacity	Initial value	00023/00038	6%	00052–00126	4%	00170/00250	3%	00310–01800	2%	02160 or more	1%
						Inverter capacity					Initial value											
						00023/00038					6%											
00052–00126	4%																					
00170/00250	3%																					
00310–01800	2%																					
02160 or more	1%																					
46	Second torque boost	0.1%	9999	0–30%	Set the torque boost when the RT signal is on.	✓	✓	✓														
				9999	Without second torque boost																	
112	Third torque boost	0.1%	9999	0–30%	Set the torque boost when the X9 signal is on.	✓	✓	✓														
				9999	Without third torque boost																	
Minimum/maximum frequency 	1 ⊙	Maximum frequency	0.01Hz	120/ 60Hz *	0–120Hz	Set the upper limit of the output frequency * The setting depends on the inverter capacity: (01800 or less/02160 or more)	✓	✓	✓	6-168												
	2 ⊙	Minimum frequency	0.01Hz	0Hz	0–120Hz	Set the lower limit of the output frequency	✓	✓	✓													
						18					High speed maximum frequency	0.01Hz	120/ 60Hz *	120–400Hz	Set when performing operation at 120 Hz or more * The setting depends on the inverter capacity: (01800 or less/02160 or more)	✓	✓	✓				

Tab. 6-1: Parameter overview (1)

Function	Parameter	Name	Increments	Initial Value	Setting Range	Description	Parameter copy	Parameter clear	All parameter clear	Refer to page	
							✓: enabled —: disabled				
Base frequency, voltage	3	⊙	Base frequency	0.01Hz	50Hz	0–400Hz	Set the frequency when the motor rated torque is generated. (50Hz/60Hz)	✓	✓	✓	6-172
		19	Base frequency voltage	0.1V	8888	0–1000V	Maximum inverter output voltage	✓	✓	✓	
	8888					95% of power supply voltage	✓	✓	✓		
	9999					Same as power supply voltage	✓	✓	✓		
	47	Second V/f (base frequency)	0.01Hz	9999	0–400Hz	Set the base frequency when the RT signal is on.	✓	✓	✓		
					9999	Second V/f is invalid.	✓	✓	✓		
113	Third V/f (base frequency)	0.01Hz	9999	0–400Hz	Set the base frequency when the X9 signal is on.	✓	✓	✓			
				9999	Third V/f is invalid.	✓	✓	✓			
Multi-speed setting operation	4	⊙	Multi-speed setting (high speed)	0.01Hz	50Hz	0–400Hz	Set frequency when the RH signal is on.	✓	✓	✓	6-183
		⊙	Multi-speed setting (middle speed)	0.01Hz	30Hz	0–400Hz	Set frequency when the RM signal is on.	✓	✓	✓	
	6	⊙	Multi-speed setting (low speed)	0.01Hz	10Hz	0–400Hz	Set frequency when the RL signal is on.	✓	✓	✓	
		<sup>24</sup> / <sub>27</sub>	Multi-speed setting 4 speed to 7 speed	0.01Hz	9999	0–400Hz/9999	Frequency from 4 speed to 15 speed can be set according to the combination of the RH, RM, RL and REX signals. 9999: not selected	✓	✓	✓	
		<sup>232</sup> / <sub>239</sub>	Multi-speed setting 8 speed to 15 speed	0.01Hz	9999	0–400Hz/9999		✓	✓	✓	

Tab. 6-1: Parameter overview (2)

Function	Parameter	Name	Increments	Initial Value	Setting Range	Description	Para- meter copy	Para- meter clear	All para- meter clear	Refer to page		
							✓: enabled —: disabled					
Acceleration/deceleration time setting	7	⊙	Acceleration time	0.1/ 0.01s	5/15s *	0–3600/ 360s	Set the motor acceleration time * Initial values differ according to the inverter capacity: (00170 or less/00250 or more)	✓	✓	✓	6-195	
	8	⊙	Deceleration time	0.1/ 0.01s	5/15s *	0–3600/ 360s	Set the motor deceleration time * Initial values differ according to the inverter capacity: (00170 or less/00250 or more)	✓	✓	✓		
	20		Acceleration/ deceleration reference frequency	0.01Hz	50Hz	1–400Hz	Set the frequency referenced as acceleration/deceleration time. As acceleration/deceleration time, set the frequency change time from stop to Pr. 20.	✓	✓	✓		
	21		Acceleration/ deceleration time increments	1	0	0	Increments: 0.1s Range: 0–3600s	Increments and setting range of acceleration/ deceleration time setting can be changed.	✓	✓		✓
						1	Increments: 0.1s Range: 0–360s		✓	✓		✓
	44		Second acceleration/ deceleration time	0.1/ 0.01 s	5s	0–3600/ 360s	Set the acceleration/deceleration time when the RT signal is on.	✓	✓	✓		
	45		Second deceleration time	0.1/ 0.01s	9999	0–3600/ 360s	Set the deceleration time when the RT signal is on.	✓	✓	✓		
						9999	Acceleration time = deceleration time					
	110		Third acceleration/ deceleration time	0.1/ 0.01s	9999	0–3600/ 360s	Set the acceleration/deceleration time when the X9 signal is on.	✓	✓	✓		
						9999	Function invalid					
111		Third deceleration time	0.1/ 0.01s	9999	0–3600/ 360s	Set the deceleration time when the X9 signal is on.	✓	✓	✓			
					9999	Acceleration time = deceleration time						

**Tab. 6-1:** Parameter overview (3)

Function	Parameter	Name	Increments	Initial Value	Setting Range	Description	Parameter copy	Parameter clear	All parameter clear	Refer to page	
							✓: enabled —: disabled				
Motor protection from overheat (electronic thermal relay function)	9	⊙	Electronic thermal O/L relay	0.01/0.1A *	Rated inverter output current	0–500/0–3600A *	Set the rated motor current. * The setting depends on the inverter capacity: (01800 or less/02160 or more)	✓	✓	✓	6-212
		51	Second electronic thermal O/L relay	0.01/0.1A *	9999	0–500/0–3600A *	Made valid when the RT signal is on. Set the rated motor current. * The setting depends on the inverter capacity: (01800 or less/02160 or more)	✓	✓	✓	
	9999					Second electronic thermal O/L relay invalid					
DC injection brake	10		DC injection brake operation frequency	0.01Hz	3Hz	0–120Hz	Set the operation frequency of the DC injection brake.	✓	✓	✓	6-241
						9999	Operate when the output frequency becomes less than or equal to Pr. 13 "Starting frequency".				
	11	DC injection brake operation time	0.1s	0.5s	0	DC injection brake disabled	✓	✓	✓		
					0.1–10s	Set the operation time of the DC injection brake.					
					8888	Operate DC injection brake for the time X13 signal is on.					
	12	DC injection brake operation voltage	0.1%	4/2/1% *	0	DC injection brake disabled	✓	✓	✓		
					0.1–30%	Set the DC injection brake voltage (torque). * Initial values differ according to the inverter capacity: (00250 or less/00310–01800/02160 or more)					
					0	Zero speed control				Setting can be made under vector control.	
					1	Servo lock					
	802	Pre-excitation selection	1	0	0	Zero speed control	✓	✓	✓		
1					Servo lock						
0					DC injection brake						
850	Brake operation selection	1	0	1	Zero speed control (under real sensorless vector control)	✓	✓	✓			
				2	Magnetic flux decay output shutoff						
Starting frequency	13		Starting frequency	0.01Hz	0.5Hz	0–60Hz	Starting frequency can be set.	✓	✓	✓	6-199
						571	Holding time at a start				
	9999	Holding function at start is invalid.									

Tab. 6-1: Parameter overview (4)

Function	Parameter	Name	Increments	Initial Value	Setting Range	Description	Parameter copy	Parameter clear	All parameter clear	Refer to page	
							✓: enabled —: disabled				
V/f pattern matching applications 	14	Load pattern selection	1	0	0	For constant torque load	✓	✓	✓	6-175	
					1	For variable-torque load					
					2	For constant torque lift					Boost for reverse rotation 0%
					3						Boost for forward rotation 0%
					4	RT signal ON: For constant-torque load (same as in setting 0) RT signal OFF: For constant-torque lift, boost for reverse rotation 0% (same as in setting 2)					
					5	RT signal ON: For constant-torque load (same as in setting 0) RT signal OFF: For constant-torque lift, boost for forward rotation 0% (same as in setting 3)					
Jog operation	15	Jog frequency	0.01 Hz	5Hz	0–400Hz	Set the frequency for jog operation.	✓	✓	✓	6-186	
	16	Jog acceleration/ deceleration time	0.1/ 0.01 s	0.5s	0–3600s/ 360s	Set the acceleration/deceleration time for jog operation. Set the time taken to reach the frequency set in Pr. 20 "Acceleration/deceleration reference frequency" for acceleration/deceleration time (initial value is 50Hz). In addition, acceleration/deceleration time can not be set separately.	✓	✓	✓		
MRS input selection	17	MRS input selection	1	0	0	Open input always	✓	✓	✓	6-293	
					2	Normally closed input (NC contact input specifications)					
					4	External terminal: Normally closed input (NC contact input specifications) Communication: Normally open input					
—	18	Refer to Pr. 1 and Pr. 2									
	19	Refer to Pr. 3									
	20 21	Refer to Pr. 7 and Pr. 8									



Tab. 6-1: Parameter overview (5)

Function	Parameter	Name	Increments	Initial Value	Setting Range	Description	Parameter copy	Parameter clear	All parameter clear	Refer to page
							✓: enabled —: disabled			
Stall prevention operation	22	Stall prevention operation level	0.1%	150%	0	Stall prevention operation selection becomes invalid.	✓	✓	✓	6-155
					0.1-400%	Function as stall prevention operation under V/f control and advanced magnetic flux vector control. Set the current value at which stall prevention operation is started. Refer to page 6-7 for torque limit level.				
	23	Stall prevention operation level compensation factor at double speed	0.1%	9999	0-200%	The stall operation level can be reduced when operating at a high speed above the rated frequency.	✓	✓	✓	
					9999	Constant according to Pr. 22				
	48	Second stall prevention operation current	0.1%	150%	0	Second stall prevention operation invalid	✓	✓	✓	
					0.1-220%	The stall prevention operation level can be set.				
	49	Second stall prevention operation frequency	0.01Hz	0Hz	0	Second stall prevention operation invalid	✓	✓	✓	
					0.01-400Hz	Set the frequency at which stall prevention operation of Pr. 48 is started.				
					9999	Pr. 48 is valid when the RT signal is on.				
	66	Stall prevention operation reduction starting frequency	0.01Hz	50Hz	0-400Hz	Set the frequency at which the stall operation level is started to reduce.	✓	✓	✓	
	114	Third stall prevention operation current	0.1%	150%	0	Third stall prevention operation invalid	✓	✓	✓	
					0.1-220%	The stall prevention operation level can be set.				
	115	Third stall prevention operation frequency	0.01Hz	0	0	Third stall prevention operation invalid	✓	✓	✓	
					0.01-400Hz	Set the frequency at which stall prevention operation of Pr. 114 is started.				
	148	Stall prevention level at 0V input.	0.1%	150%	0-220%	When "4" is set in Pr. 868 (Pr. 858), stall prevention operation level can be changed by the analog signal input to terminal 1 (terminal 4).	✓	✓	✓	
	149	Stall prevention level at 10V input.	0.1%	200%	0-220%		✓	✓	✓	
	154	Voltage reduction selection during stall prevention operation	1	1	0	With voltage reduction	✓	✓	✓	
					1	Without voltage reduction				
							You can select whether to use output voltage reduction during stall prevention operation or not.			
	156	Stall prevention operation selection	1	0	0-31/100/101	Pr. 156 allows you to select whether to use stall prevention or not according to the acceleration/deceleration status.	✓	✓	✓	
	157	OL signal output timer	0.1s	0s	0-25s	Set the output start time of the OL signal output when stall prevention is activated.	✓	✓	✓	
					9999	Without the OL signal output				
858	Terminal 4 function assignment	Refer to page 6-60								
868	Terminal 1 function assignment									

Tab. 6-1: Parameter overview (6)

Function	Parameter		Increments	Initial Value	Setting Range	Description	Parameter copy	Parameter clear	All parameter clear	Refer to page		
	Related parameters	Name					✓: enabled —: disabled					
Torque limit level <span style="border: 1px solid black; padding: 2px;">Vector</span> <span style="border: 1px solid black; padding: 2px;">Sensorless</span>			22	Torque limit level	0.1%	150%/200%*	0–400%	This functions as torque limit level under real sensorless vector control and vector control. * For the 00126 or less, the initial value changes from 150% to 200% when V/f control or advanced magnetic flux vector is changed to real sensorless vector control or vector control. Refer to page 6-6 for stall prevention operation level.	✓	✓	✓	6-80
	803	Constant power range torque characteristic selection		1	0	0	Constant output limit (torque current limit and control)	✓	✓	✓		
						1	Constant torque limit (torque limit and control)					
	810	Torque limit input method selection		1	0	0	Internal torque limit Parameter-set torque limit operation is performed.	✓	✓	✓		
						1	External torque limit Torque limit based on the analog input from terminal 1 and 4.					
	811	Set resolution switchover		1	0	0	Running speed increments	✓	✓	✓		
						1	1r/min				0.1% increments	
						10	0.1r/min					
						11	1r/min				0.01% increments	

Tab. 6-1: Parameter overview (7)

Function	Parameter		Increments	Initial Value	Setting Range	Description	Parameter copy	Parameter clear	All parameter clear	Refer to page
	Related parameters	Name								
Torque limit level  	812	Torque limit level (regeneration)	0.1%	9999	0-400%	Set the torque limit level for forward rotation regeneration.	✓	✓	✓	6-80
					9999	Pr. 22 value is used for limit.				
	813	Torque limit level (3rd quadrant)	0.1%	9999	0-400%	Set the torque limit level for reverse rotation driving.	✓	✓	✓	
					9999	Pr. 22 value is used for limit.				
	814	Torque limit level (4th quadrant)	0.1%	9999	0-400%	Set the torque limit level for reverse rotation regeneration.	✓	✓	✓	
					9999	Pr. 22 value is used for limit.				
	815	Torque limit level 2	0.1%	9999	0-400%	When the torque limit selection (TL) signal is on, the Pr. 815 value is a torque limit value regardless of Pr. 810.	✓	✓	✓	
					9999	Pr. 22 value is used for limit.				
816	Torque limit level during acceleration	0.1%	9999	0-400%	Set the torque limit value during acceleration.	✓	✓	✓		
				9999	Same torque limit as at constant speed					
817	Torque limit level during deceleration	0.1%	9999	0-400%	Set the torque limit value during deceleration.	✓	✓	✓		
				9999	Same torque limit as at constant speed					
874	OLT level setting	0.1%	150%	0-200%	This function can make an alarm stop if the torque limit is activated to stall the motor. Set the output torque at which an alarm stop is made in Pr. 874.	✓	✓	✓		
—	24 — 27	Refer to Pr. 4 to Pr. 6								
Compensation of the set frequency	28	Multi-speed input compensation selection	1	0	0	Without compensation	✓	✓	✓	6-190
					1	With compensation				

Tab. 6-1: Parameter overview (8)



Function	Parameter	Name	Increments	Initial Value	Setting Range	Description	Parameter copy	Parameter clear	All parameter clear	Refer to page
							✓: enabled —: disabled			
Acceleration/deceleration pattern and backlash compensation	29	Acceleration/deceleration pattern selection	1	0	0	Linear acceleration/deceleration	✓	✓	✓	6-201
					1	S-pattern acceleration/deceleration A				
					2	S-pattern acceleration/deceleration B				
					3	Backlash measures				
					4	S-pattern acceleration/deceleration C				
					5	S-pattern acceleration/deceleration D				
	140	Backlash acceleration stopping frequency	0.01Hz	1Hz	0–400Hz	Set the stopping frequency and time for backlash measures. Valid when Pr. 29 = 3	✓	✓	✓	
	141	Backlash acceleration stopping time	0.1s	0.5s	0–360s		✓	✓	✓	
	142	Backlash deceleration stopping frequency	0.01Hz	1Hz	0–400Hz		✓	✓	✓	
	143	Backlash deceleration stopping time	0.1s	0.5s	0–360s		✓	✓	✓	
	380	Acceleration Spattern 1	1%	0%	0–50%	Valid when S-pattern acceleration/deceleration C (Pr. 29 = 4) is set. Set the time taken for S-pattern from starting of acceleration/deceleration to linear acceleration as % to the acceleration/deceleration time (Pr. 7, Pr. 8, etc.) An acceleration/deceleration pattern can be changed with the X20 signal.	✓	✓	✓	
	381	Deceleration Spattern 1	1%	0%	0–50%		✓	✓	✓	
	382	Acceleration Spattern 2	1%	0%	0–50%		✓	✓	✓	
	383	Deceleration Spattern 2	1%	0%	0–50%		✓	✓	✓	
	516	S-pattern time at a start of acceleration	0.1s	0.1s	0.1–2.5s	Valid when S-pattern acceleration/deceleration D (Pr. 29 = 5) is set. Set the time taken for S-pattern acceleration/deceleration (S-pattern operation).	✓	✓	✓	
517	S-pattern time at a completion of acceleration	0.1s	0.1s	0.1–2.5s	✓		✓	✓		
518	S-pattern time at a start of deceleration	0.1s	0.1s	0.1–2.5s	✓		✓	✓		
519	S-pattern time at a completion of deceleration	0.1s	0.1s	0.1–2.5s	✓		✓	✓		

**Tab. 6-1:** Parameter overview (9)

Function	Parameter		Increments	Initial Value	Setting Range	Description	Parameter copy	Parameter clear	All parameter clear	Refer to page		
	Related parameters	Name					✓: enabled —: disabled					
Selection of regeneration unit			30	Regenerative function selection	1	0	0	External brake unit FR-BU and external brake resistor unit FR-BR	✓	✓	✓	6-249
	1	—					External brake unit MT-BU5, power regeneration converter MT-RC					
	2						High-duty brake resistor (FR-ABR), brake unit (MT-BU5), power regeneration converter (MT-RC)					
	10						Built-in brake unit, brake unit (FR-BU)	DC feeding mode 1 (operated by DC feeding only)				
	11						High-duty brake resistor (FR-ABR), brake unit (MT-BU5)					
	20						Built-in brake unit, brake unit (FR-BU)	DC feeding mode 2 (operated by switching between AC and DC)				
	21						High-duty brake resistor (FR-ABR), brake unit (MT-BU5)					
70	Special regenerative brake duty	0.1%	0%	0-30%/0-10%*	You can set the brake duty when a brake unit or power regeneration converter is used. Setting can be made for the 01800 or more. * The setting depends on the inverter capacity: (01800 or less/02160 or more)	✓	✓	✓				
Avoid mechanical resonance points	31	Frequency jump 1A	0.01Hz	9999	0-400Hz/9999	1A to 1B, 2A to 2B, 3A to 3B are frequency jumps 9999: Function invalid	✓	✓	✓	6-170		
	32	Frequency jump 1B	0.01Hz	9999	0-400Hz/9999		✓	✓	✓			
	33	Frequency jump 2A	0.01Hz	9999	0-400Hz/9999		✓	✓	✓			
	34	Frequency jump 2B	0.01Hz	9999	0-400Hz/9999		✓	✓	✓			
	35	Frequency jump 3A	0.01Hz	9999	0-400Hz/9999		✓	✓	✓			
	36	Frequency jump 3B	0.01Hz	9999	0-400Hz/9999		✓	✓	✓			

Tab. 6-1: Parameter overview (10)

Function	Parameter	Name	Increments	Initial Value	Setting Range	Description	Parameter copy	Parameter clear	All parameter clear	Refer to page
							✓: enabled —: disabled			
Speed display and speed setting	37	Speed display	1	0	0	Frequency display, setting	✓	✓	✓	6-321
					1–9998	Set the machine speed at 60Hz.				
	144	Speed setting switch over	1	4	0/2/4/6/8/10/102/104/106/108/110	Set the machine speed for Pr.505 set frequency.	✓	✓	✓	
	505	Speed setting reference	0.01Hz	50Hz	1–120Hz	Set the frequency that will be the basis of machine speed display.	✓	✓	✓	
	811	Easy gain tuning response level setting	1	0		Running speed increments	✓	✓	✓	
					0	Torque limit increments				
					1	0.1% increments				
10					0.01% increments					
				11	0.1r/min					
Detection of output frequency and motor speed (SU, FU, FU2, FU3, FB, FB2, FB3, LS signal)	41	Up-to-frequency sensitivity (SU output)	0.1%	10%	0–100%	Set the level where the SU signal turns on.	✓	✓	✓	6-312
	42	Output frequency detection (FU output)	0.01Hz	6Hz	0–400Hz	Set the frequency where the FU (FB) signal turns on.	✓	✓	✓	
	43	Output frequency detection for reverse rotation	0.01Hz	9999	0–400Hz	Set the frequency where the FU (FB) signal turns on in reverse rotation.	✓	✓	✓	
					9999	Same as Pr. 42 setting				
	50	Second output frequency detection	0.01Hz	30Hz	0–400Hz	Set the frequency where the FU2 (FB2) signal turns on.	✓	✓	✓	
	116	Third output frequency detection	0.01Hz	60Hz	0–400Hz	Set the frequency where the FU3 (FB3) signal turns on.	✓	✓	✓	
865	Low speed detection	0.01Hz	1.5Hz	0–400Hz	Set the frequency where the LS signal turns on.	✓	✓	✓		
—	44 45	Refer to Pr. 7 and Pr. 8								
	46	Refer to Pr. 0								
	47	Refer to Pr. 3								
—	48 49	Refer to Pr. 22 and Pr. 23								
	50	Refer to Pr. 41 to Pr. 43								
—	51	Refer to Pr. 9								

**Tab. 6-1:** Parameter overview (11)

Function	Parameter		Incre-ments	Initial Value	Setting Range	Description	Para-meter copy	Para-meter clear	All para-meter clear	Refer to page
	Related parameters	Name					✓: enabled —: disabled			
Display functions		52	DU/PU main display data selection	1	0	0/5-14/ 17-20/ 22-25/ 32-35/46 50-57/100	Select monitor to be displayed on the operation panel and parameter unit and monitor to be output to the terminal AM and CA. 0: Output frequency (Pr. 52)	✓	✓	✓
	54	CA terminal function selection	1	1		1: Output frequency (Pr. 54, Pr. 158) 2: Output current (Pr. 54, Pr. 158) 3: Output voltage (Pr. 54, Pr. 158) 5: Frequency setting 6: Running speed 7: Motor torque 8: Converter output voltage 9: Regenerative brake duty 10: Electronic thermal relay function load factor 11: Output current peak value 12: Converter output voltage peak value 13: Input power 14: Output power 17: Load meter 18: Motor excitation current 19: Position pulse * (Pr. 52) 20: Cumulative energization time (Pr. 52) 21: Reference voltage output (Pr. 54, Pr. 158) 22: Orientation status * (Pr. 52) 23: Actual operation time (Pr. 52)	✓	✓	✓	
	158	AM terminal function selection	1	1	1-3/5-14/ 17/18/21/ 24/32-34/ 46/50/52/ 53/70	24: Motor load factor 25: Cumulative power (Pr. 52) 32: Torque command 33: Torque current command 34: Motor output 35: Feedback pulse * (Pr. 52) 46: Motor temperature monitor (available with FR-A7AZ only) 50: Power saving effect 51: Cumulative saving power (Pr. 52) 52: PID set point 53: PID measured value 54: PID deviation (Pr. 52) 55: Input/output terminal status (Pr. 52) 56: Option input terminal status (Pr. 52) 57: Option output terminal status (Pr. 52) 70: PLC function output 100: Set frequency is displayed during a stop and output frequency is displayed during operation (Pr. 52). * Available only when the FR-A7AP is mounted.	✓	✓	✓	

Tab. 6-1: Parameter overview (12)

Function	Parameter	Name	Increments	Initial Value	Setting Range	Description	Para- meter copy	Para- meter clear	All para- meter clear	Refer to page									
							✓: enabled —: disabled												
Display functions	170	Watt-hour meter clear	1	9999	0	Set "0" to clear the watt-hour meter monitor.	✓	—	✓	6-324									
					10	Set the maximum value when monitoring from communication to 0 to 9999kWh.													
					9999	Set the maximum value when monitoring from communication to 0 to 65535kWh.													
	171	Operation hour meter clear	1	9999	0/9999	Set "0" in the parameter to clear the watt hour monitor. Setting "9999" has no effect.	—	—	—										
	268	Monitor decimal digits selection	1	9999	0	Displays the monitor as integral value.	✓	✓	✓										
					1	Displays the monitor in increments of 0.1.													
					9999	No fixed decimal position													
	563	Energizing time carrying-over times	1	0	0-65535	The numbers of cumulative energizing time monitor exceeded 65535h is displayed. Reading only	—	—	—										
	564	Operating time carrying-over times	1	0	0-65535	The numbers of operation time monitor exceeded 65535h is displayed. Reading only	—	—	—										
	891	Cumulative power monitor digit shifted times	1	9999	0-4	Set the number of times to shift the cumulative power monitor digit. Clamp the monitor value at maximum.	✓	✓	✓										
9999					No shift Clear the monitor value when it exceeds the maximum value.														
Change of the monitor output from terminal CA and AM	55	Frequency monitoring reference	0.01 Hz	50Hz	0-400Hz	Set the full-scale value to output the output frequency monitor value to terminal CA and AM.	✓	✓	✓	6-333									
	56	Current monitoring reference	0.01/ 0.1 A *	Rated inverter output current	0-500/ 0-3600A *	Set the full-scale value to output the output current monitor value to terminal CA and AM. * The setting depends on the inverter capacity: (01800 or less/02160 or more)	✓	✓	✓										
											866	Torque monitoring reference	0.1%	150%	0-400%	Set the full-scale value to output the torque monitor value to terminal CA and AM.	✓	✓	✓
											867	AM output filter	0.01s	0.01s	0-5s	Set the output filter of terminal AM.	✓	✓	✓
											869	Current output filter	0.01s	0.02s	0-5s	Adjust response level of current output.	✓	✓	✓

Tab. 6-1: Parameter overview (13)

Function	Parameter Related parameters	Name	Increments	Initial Value	Setting Range	Description	Para- meter copy	Para- meter clear	All para- meter clear	Refer to page
							✓: enabled —: disabled			
Restart operation after instantaneous power failure	57	Restart coasting time	0.1s	9999	0	The coasting time is as follows: 00052 or less:..... 0.5s, 00083–00250: ..... 1s, 00310–01800: ..... 3.0s, 02160 or more:..... 5.0s	✓	✓	✓	6-340
					0,1–5s/ 0.1–30s *	Set the waiting time for inverter-triggered restart after an instantaneous power failure. * The setting depends on the inverter capacity: (01800 or less/02160 or more)				
					9999	No restart				
	58	Restart cushion time	0.1s	1s	0–60s	Set a voltage starting time at restart.	✓	✓	✓	
						0				
	162	Automatic restart after instantaneous power failure selection	1	0	1	Without frequency search (Reduced voltage system)	✓	✓	✓	
					2	Encoder detection frequency				
					10	Frequency search at every start				
					11	Reduced voltage system at every start				
	163	First cushion time for restart	0.1s	0s	0–20s	Set a voltage starting time at restart.	✓	✓	✓	
						164				
	165	Stall prevention operation level for restart	0.1%	150%	0–220%	Consider the rated inverter current as 100% and set the stall prevention operation level during restart operation.	✓	✓	✓	
	299	Rotation direction detection selection at restarting	1	9999	0	Without rotation direction detection	✓	✓	✓	
					1	With rotation direction detection				
9999					When Pr. 78 = "0", the rotation direction is detected. When Pr. 78 = "1", "2", the rotation direction is not detected.					
611	Acceleration time at a restart	0.1s	5/15s *	0–3600s	Set the acceleration time to reach the set frequency at a restart. * The setting depends on the inverter capacity: (01800 or less/02160 or more)	✓	✓	✓		
				9999	Acceleration time for restart is the normal acceleration time (e.g. Pr. 7).					

Tab. 6-1: Parameter overview (14)

Function	Parameter Related parameters	Name	Increments	Initial Value	Setting Range	Description		Parameter copy	Parameter clear	All parameter clear	Refer to page	
								✓: enabled —: disabled				
Remote setting function	59	Remote function selection	1	0	0	RH, RM, RL signal function	Frequency setting storage function	✓	✓	✓	6-191	
						Multi-speed setting	—					
						Remote setting	Yes					
						Remote setting	No					
Energy saving control selection 	60	Energy saving control selection	1	0	0	Normal operation mode		✓	✓	✓	6-362	
					4	Energy saving operation mode						
Automatic acceleration/deceleration	61	Reference current	0.01/ 0.1 A *	9999	0-500/ 0-3600 A *	Setting value (rated motor current) is referenced * The increments and setting range differ according to the inverter capacity: (01800 or less/02160 or more)		✓	✓	✓	6-178, 6-208	
					9999	Rated inverter current is referenced						
	62	Reference value at acceleration	0.1%	9999	0-220%	0-220% is the setting range Pr. 61 is the reference value	Low values for smooth acceleration		✓	✓		✓
					9999	150% is a limit value Pr. 61 is the reference value	Shortest acceleration time Optimum acceleration					
	63	Reference value at deceleration	0.1%	9999	0-220%	0-220% is the setting range Pr. 61 is the reference value	Low values for smooth deceleration		✓	✓		✓
					9999	150% is a limit value Pr. 61 is the reference value	Shortest deceleration time Optimum deceleration					

Tab. 6-1: Parameter overview (15)

Function	Parameter	Name	Increments	Initial Value	Setting Range	Description	Parameter copy	Parameter clear	All parameter clear	Refer to page	
							✓: enabled —: disabled				
Automatic acceleration/deceleration	64	Starting frequency for elevator mode	0.01Hz	9999	0–10Hz	0 to 10Hz are starting frequency	✓	✓	✓	6-178	
					9999	2Hz is starting frequency					
	292	Automatic acceleration/deceleration	1	0	0	Normal mode	✓	✓	✓		
					1	Shortest acceleration/deceleration mode					Without brake
					11						With brake
					3	Optimum acceleration/deceleration mode					
					5	Elevator mode 1					
					6	Elevator mode 2					
					7	Brake sequence mode 1					
					8	Brake sequence mode 2					
	293	Acceleration/deceleration separate selection	1	0	0	Calculate acceleration/deceleration time of both acceleration and deceleration for the shortest and optimum acceleration/deceleration mode.	✓	✓	✓		
					1	Calculate only acceleration time for the shortest and optimum acceleration/deceleration mode					
					2	Calculate only deceleration time for the shortest and optimum acceleration/deceleration mode					
Retry function at alarm occurrence	65	Retry selection	1	0	0–5	An alarm for retry can be selected.	✓	✓	✓		
					0	No retry function					
	67	Number of retries at alarm occurrence	1	0	1–10	Set the number of retries at alarm occurrence. An alarm output is not provided during retry operation.	✓	✓	✓		
					101–110	Set the number of retries at alarm occurrence. (The setting value minus 100 is the number of retries.) An alarm output is provided during retry operation.					
					68	Retry waiting time				0.1s	1s
69	Retry count display erase	1	0	0	Clear the number of restarts succeeded by retry.	✓	✓	✓			
—	66	Refer to Pr. 22 and Pr. 23									
—	67 – 69	Refer to Pr. 65									
—	70	Refer to Pr. 30									

Tab. 6-1: Parameter overview (16)



Function	Parameter	Name	Increments	Initial Value	Setting Range	Description	Parameter copy	Parameter clear	All parameter clear	Refer to page		
							✓: enabled —: disabled					
Applied motor	71	Applied motor	1	0	0	Thermal characteristics of a standard motor	✓	✓	✓	6-218		
					1	Thermal characteristics of the Mitsubishi constant-torque motor						
					2	Thermal characteristic of standard motor Adjustable 5 points V/f						
					20	Mitsubishi standard motor (SF-JR 4P 1.5kW or less)						
					30	Thermal characteristics of the Mitsubishi vector motor SF-V5RU						
					40	Thermal characteristic of Mitsubishi high efficiency motor (SF-HR)						
					50	Thermal characteristic of Mitsubishi constant-torque motor (SF-HRCA)						
					3	Standard motor					Select "offline auto tuning setting"	
					13	Constant-torque motor						
					23	Mitsubishi standard motor (SF-JR 4P 1.5kW or less)						
					33	Mitsubishi vector motor (SF-V5RU/SF-THY)						
					43	Mitsubishi high efficiency motor (SF-HR)						
					53	Mitsubishi constant-torque motor (SF-HRCA)						
					4	Standard motor						Auto tuning data can be read, changed, and set.
					14	Constant-torque motor						
					24	Mitsubishi standard motor (SF-JR 4P 1.5kW or less)						
					34	Mitsubishi vector motor (SF-V5RU/SF-THY)						
					44	Mitsubishi high efficiency motor (SF-HR)						
					54	Mitsubishi constant-torque motor (SF-HRCA)						

**Tab. 6-1:** Parameter overview (17)

Function	Parameter	Name	Increments	Initial Value	Setting Range	Description	Parameter copy	Parameter clear	All parameter clear	Refer to page
							✓: enabled —: disabled			
Applied motor	71	Applied motor	1	0	5	Standard motor Star connection Direct input of motor constants is enabled	✓	✓	✓	6-218
					15	Constant-torque motor				
					6	Standard motor Delta connection Direct input of motor constants is enabled				
					16	Constant-torque motor				
					7	Standard motor Star connection Motor constants direct input + Offline auto tuning				
					17	Constant-torque motor				
					8	Standard motor Delta connection Motor constants direct input + Offline auto tuning				
					18	Constant-torque motor				
	450	Second applied motor	1	9999	0-8/13-18/ 20/23/24/ 30/33/34/ 40/43/44/ 50/53/54 9999	Set when using the second motor. (same specifications as Pr. 71) Second motor is invalid	✓	✓	✓	
Carrier frequency and Soft-PWM selection	72	PWM frequency selection	1	2	0-15/ 0-6/25 *	PWM carrier frequency can be changed. The setting displayed is in [kHz]. Note that 0 indicates 0.7kHz, 15 indicates 14.5kHz and 25 indicates 2.5kHz. (25 is exclusively for a sine wave filter.) The following settings are for real sensorless vector control and vector control: 0 to 5: 2kHz, 6 to 9: 6kHz, 10 to 13: 10kHz, 14 to 15: 14kHz * The setting depends on the inverter capacity: (01800 or less/02160 or more)	✓	✓	✓	6-370
					0	Soft-PWM invalid	✓	✓	✓	
					1	When Pr. 72 = "0 to 5" ("0 to 4" for the 02160 or more), Soft-PWM is valid.	✓	✓	✓	
					260	PWM frequency automatic switch over	1	1	0	
	1	Decreases PWM carrier frequency automatically when load increases.	✓	✓	✓					

Tab. 6-1: Parameter overview (18)

Function	Parameter	Name	Increments	Initial Value	Setting Range	Description	Parameter copy	Parameter clear	All parameter clear	Refer to page		
							✓: enabled —: disabled					
Analog input selection	73	Analog input selection	1	1	0-7/10-17	You can select the input specifications of terminal 2 (0 to 5V, 0 to 10V, 4 to 20mA) and input specifications of terminal 1 (0 to ±5V, 0 to ±10V). For the 00170 or more, the input specifications can be selected when the voltage/current input switch is off. Terminal 2 is always used for current input when the switch is on, the parameter needs to be set to current input. Override and reversible operation can be selected.	✓	—	✓	6-372		
		242	Terminal 1 added compensation amount (terminal 2)	0.1%	100%	0-100%	Set the ratio of added compensation amount when terminal 2 is the main speed.	✓	✓		✓	
		243	Terminal 1 added compensation amount (terminal 4)	0.1%	75%	0-100%	Set the ratio of added compensation amount when terminal 4 is the main speed.	✓	✓		✓	
		252	Override bias	0.1%	50%	0-200%	Set the bias side compensation value of override function.	✓	✓		✓	
		253	Override gain	0.1%	150%	0-200%	Set the gain side compensation value of override function.	✓	✓		✓	
		267	Terminal 4 input selection	1	0	0	Terminal 4 input 0/4 to 20mA	For the 00170 or more, the input specifications can be selected when the voltage/current input switch is off. Set "0" when the switch is ON.	✓		—	✓
						1	Terminal 4 input 0 to 5V					
						2	Terminal 4 input 0 to 10V					
		573	4mA input check selection	1	9999	1	When the current input drops to or below 2mA, the LF signal is output and inverter continues operation at the frequency (average value) just before current reaches 2mA.	✓	✓		✓	
						9999	4mA input is not checked.					

**Tab. 6-1:** Parameter overview (19)

Function	Parameter	Name	Increments	Initial Value	Setting Range	Description	Parameter copy	Parameter clear	All parameter clear	Refer to page	
							✓: enabled —: disabled				
Noise elimination at the analog input	74	Input filter time constant	1	1	0–8	The primary delay filter time constant for the analog input can be set. A larger setting results in a larger filter.	✓	✓	✓	6-383	
		822	Speed setting filter 1	0.001s	9999	0–5s/9999	Set the time constant of the primary delay filter relative to the external speed command (analog input command).	✓	✓		✓
		826	Torque setting filter 1	0.001s	9999	0–5s/9999	Set the time constant of the primary delay filter relative to the external torque command (analog input command).	✓	✓		✓
		832	Speed setting filter 2	0.001s	9999	0–5s/9999	Second function of Pr. 822 (valid when the RT terminal is on)	✓	✓		✓
		836	Torque setting filter 2	0.001s	9999	0–5s/9999	Second function of Pr. 826 (valid when the RT terminal is on)	✓	✓		✓
		849	Analog input offset adjustment	0.1%	100%	0–200%	This function provides speed command by analog input (terminal 2) with offset and avoids frequency command to be given due to noise under 0 speed command.	✓	✓		✓
Reset selection/ disconnected PU/PU stop	75	Reset selection/disconnected PU detection/ PU stop selection	1	14	0–3/14–17/ 100–103/ 114–117 * <i>* 100 to 103 and 114 to 117 can be set only for Q2160 or more.</i>	You can select the reset input acceptance, disconnected PU (FR-DU07/FR-PU07/FRPU04) connector detection function and PU stop function. For the initial value, reset always enabled, without disconnected PU detection, and with PU stop function are set.	✓	—	—	6-406	
Output function of alarm code	76	Alarm code output selection	1	0	0	Without alarm code output	✓	✓	✓	6-358	
					1	With alarm code output					
					2	Alarm code output at alarm occurrence only					

**Tab. 6-1:** Parameter overview (20)

Function	Parameter		Increments	Initial Value	Setting Range	Description	Parameter copy	Parameter clear	All parameter clear	Refer to page
	Related parameters	Name					✓: enabled —: disabled			
Prevention of parameter rewrite			77	Parameter write selection	1	0	0	Write is enabled only during a stop	✓	✓
	1	Parameter write is disabled.								
	2	Parameter write is enabled in any operation mode regardless of operation status. <i>Note:</i> <i>Parameters that generally can't be written during operation, can't be written with this setting either.</i>								
Prevention of reverse rotation of the motor	78	Reverse rotation prevention selection	1	0	0	Both forward and reverse rotations allowed	✓	✓	✓	6-414
					1	Reverse rotation disallowed				
					2	Forward rotation disallowed				
Operation mode selection	79	⊙ Operation mode selection	1	0	0	External/PU switch over mode	✓	✓	✓	6-418
					1	Fixed to PU operation mode				
					2	Fixed to External operation mode				
					3	External/PU combined operation mode 1				
					4	External/PU combined operation mode 2				
					6	Switch-over mode				
					7	External operation mode (PU operation interlock)				
	340	Communication start-up mode selection	1	0	0	As set in Pr. 79.	✓	✓	✓	6-430
					1/2	Started in the network operation mode. When the setting is "2", it will resume the preinstantaneous power failure operation mode after an instantaneous power failure occurs.				
					10/12	Started in the network operation mode. Operation mode can be changed between the PU operation mode and network operation mode from the operation panel. When the setting is "12", it will resume the preinstantaneous power failure operation mode after an instantaneous power failure occurs.				

**Tab. 6-1:** Parameter overview (21)

Function	Parameter Related parameters	Name	Increments	Initial Value	Setting Range	Description	Para- meter copy	Para- meter clear	All para- meter clear	Refer to page	
							✓: enabled —: disabled				
Selection of control method Magnetic flux Sensorless Vector	80	Motor capacity	0.01kW/ 0.1kW *	9999	0.4–55kW/ 0–3600kW *	Set the applied motor capacity. * The increments and setting range differ according to the inverter capacity. (01800 or less/02160 or more)	✓	✓	✓	6-171	
					9999	V/f control is performed.					
	81	Number of motor poles	1	9999	2/4/6/8/10	Set the number of motor poles.	✓	✓	✓		
					12/14/16/ 18/20	X18 signal-ON: V/f control	Set 10 + number of motor poles.				
					9999	V/f control is performed.					
	89	Speed control gain (magnetic flux vector)	0.1%	9999	0–200%	Motor speed fluctuation due to load fluctuation is adjusted during advanced magnetic flux vector control. 100% is a referenced value.	✓	—	✓		
					9999	Gain matching with the motor set in Pr. 71.					
	451	Second motor control method selection	1	9999	10/11/12	Select the method of controlling the second motor. (same as Pr. 800)	✓	✓	✓		
					20/9999	V/f Control (advanced magnetic flux vector control)					
	453	Second motor capacity	0.01kW/ 0.1kW *	9999	0.4–55kW/ 0–3600kW *	Set the capacity of the second motor. * The increments and setting range differ according to the inverter capacity. (01800 or less/02160 or more)	✓	✓	✓		
						V/f control is performed.					
	454	Number of second motor poles	1	9999	2/4/6/8/10	Set the number of poles of the second motor.	✓	✓	✓		
					V/f control is performed.						
569	Second motor speed control gain	0.1%	9999	0–200%	Second motor speed fluctuation due to load fluctuation is adjusted during advanced magnetic flux vector control. 100% is a referenced value.	✓	—	✓			
				9999	Gain matching with the motor set in Pr. 450.						

Tab. 6-1: Parameter overview (22)

Function	Parameter		Name	Increments	Initial Value	Setting Range	Description	Parameter copy	Parameter clear	All parameter clear	Refer to page
	Related parameters							✓: enabled —: disabled			
Selection of control method	800	Control method selection	1	20	0	Speed control	Vector control (FR-A7AP)	✓	✓	✓	6-171
					1	Torque control					
					2	MC signal-ON: torque MC signal-OFF: speed					
					3	Position control					
					4	MC signal-ON: position MC signal-OFF: speed					
					5	MC signal-ON: torque MC signal-OFF: position					
					9	Vector control test operation Test operation of vector control (speed control) can be performed without connecting a motor.					
					10	Speed control	Real sensorless vector control				
					11	Torque control					
					12	MC signal-ON: torque MC signal-OFF: speed					
20	V/f Control (advanced magnetic flux vector control)										

**Tab. 6-1:** Parameter overview (23)

Function	Parameter Related parameters	Name	Increments	Initial Value	Setting Range	Description	Parameter copy	Parameter clear	All parameter clear	Refer to page
							✓: enabled —: disabled			
Offline auto tuning Vector Sensorless Magnetic flux	82	Motor excitation current	0.01A/ 0.1A *	9999	0–500A/ 0–3600A *	Tuning data (The value measured by offline auto tuning is automatically set.) * The increments and setting range differ according to the inverter capacity. (01800 or less/02160 or more)	✓	—	✓	6-150
					9999	Use the Mitsubishi motor (SF-JR, SFHRCA) constants				
	83	Motor rated voltage	0.1V	400V	0–1000V	Set the rated motor voltage.	✓	✓	✓	
	84	Rated motor frequency	0.01Hz	50Hz	10–120Hz	Set the rated motor frequency.	✓	✓	✓	
	90	Motor constant (R1)	0.001Ω/ 0.01mΩ *	9999	0–50Ω/ 0–400mΩ *	Tuning data (The value measured by offline auto tuning is automatically set.) * The increments and setting range differ according to the inverter capacity. (01800 or less/02160 or more)	✓	—	✓	
					9999	Use the Mitsubishi motor (SF-JR, SF-HRCA) constants				
	91	Motor constant (R2)	0.001Ω/ 0.01mΩ *	9999	0–50Ω/ 0–400mΩ *	Tuning data (The value measured by offline auto tuning is automatically set.) * The increments and setting range differ according to the inverter capacity. (01800 or less/02160 or more)	✓	—	✓	
					9999	Use the Mitsubishi motor (SF-JR, SF-HRCA) constants				
	92	Motor constant (L1)	0.001Ω (0.1mH) 0.01mΩ (0.01mH) *	9999	0–50Ω (0–1000mH)/ 0–3600mΩ (0–400mH) *	Tuning data (The value measured by offline auto tuning is automatically set.) * The increments and setting range differ according to the inverter capacity. (01800 or less/02160 or more)	✓	—	✓	
					9999	Use the Mitsubishi motor (SF-JR, SF-HRCA) constants				
93	Motor constant (L2)	0.001Ω (0.1mH)/ 0.01mΩ (0.01mH) *	9999	0–50Ω (0–1000mH)/ 0–3600mΩ (0–400mH) *	Tuning data (The value measured by offline auto tuning is automatically set.) * The increments and setting range differ according to the inverter capacity. (01800 or less/02160 or more)	✓	—	✓		
				9999	Use the Mitsubishi motor (SF-JR, SF-HRCA) constants					

Tab. 6-1: Parameter overview (24)



Function	Parameter	Name	Increments	Initial Value	Setting Range	Description	Parameter copy	Parameter clear	All parameter clear	Refer to page
							✓: enabled —: disabled			
Offline auto tuning Magnetic flux Sensorless Vector	94	Motor constant (X)	0.01Ω (0.1%)/ 0.01Ω (0.01%)*	9999	0–500Ω (0–100%/ 0–100Ω (0–100mH))*	Tuning data (The value measured by offline auto tuning is automatically set.) * The increments and setting range differ according to the inverter capacity. (01800 or less/02160 or more)	✓	—	✓	6-222
					9999	Use the Mitsubishi motor (SF-JR, SF-HRCA) constants				
	96	Auto tuning setting/status	1	0	0	Auto tuning is not performed	✓	—	✓	
					1	Tuning performed without motor running				
					101	Tuning performed with motor running				
	455	Motor-Erregerstrom (Motor 2)	0.01A/ 0.1A*	9999	0–500A/ 0–3600A*	Tuning data of the second motor (The value measured by offline auto tuning is automatically set.) * The increments and setting range differ according to the inverter capacity. (01800 or less/02160 or more)	✓	—	✓	
					9999	Use the Mitsubishi motor (SF-JR, SF-HRCA) constants				
	456	Rated second motor voltage	0.1V	400V	0–1000V	Set the rated voltage of the second motor.	✓	✓	✓	
	457	Rated second motor frequency	0.01Hz	50Hz	10–120Hz	Set the rated frequency (Hz) of the second motor.	✓	✓	✓	
	458	Second motor constant (R1)	0.001Ω/ 0.01mΩ*	9999	0–50Ω/ 0–400mΩ*	Tuning data of the second motor (The value measured by offline auto tuning is automatically set.) * The increments and setting range differ according to the inverter capacity. (01800 or less/02160 or more)	✓	—	✓	
					9999	Use the Mitsubishi motor (SF-JR, SF-HRCA) constants				
	459	Second motor constant (R2)	0.001Ω/ 0.01mΩ*	9999	0–50Ω/ 0–400mΩ*	Tuning data of the second motor (The value measured by offline auto tuning is automatically set.) * The increments and setting range differ according to the inverter capacity. (01800 or less/02160 or more)	✓	—	✓	
9999					Use the Mitsubishi motor (SF-JR, SF-HRCA) constants					

Tab. 6-1: Parameter overview (25)

Function	Parameter	Name	Increments	Initial Value	Setting Range	Description	Parameter copy	Parameter clear	All parameter clear	Refer to page	
							✓: enabled —: disabled				
Offline auto tuning	Related parameters Vector Sensorless Magnetic flux	460	Second motor constant (L1)	0.001Ω (0.1mH) 0.01mΩ (0.01mH) *	9999	0–50Ω (0–1000mH)/ 0–3600mΩ (0–400mH) *	Tuning data of the second motor (The value measured by offline auto tuning is automatically set.) * The increments and setting range differ according to the inverter capacity. (01800 or less/02160 or more)	✓	—	✓	6-150
						9999					
		461	Second motor constant (L2)	0.001Ω (0.1mH)/ 0.01mΩ (0.01mH) *	9999	0–50Ω (0–1000mH)/ 0–3600mΩ (0–400mH) *	Tuning data of the second motor (The value measured by offline auto tuning is automatically set.) * The increments and setting range differ according to the inverter capacity. (01800 or less/02160 or more)	✓	—	✓	
						9999					
		462	Second motor constant (X)	0.01Ω (0.1%)/ 0.01Ω (0.01%) *	9999	0–500Ω (0–100%)/ 0–100Ω (0–100mH) *	Tuning data of the second motor (The value measured by offline auto tuning is automatically set.) * The increments and setting range differ according to the inverter capacity. (01800 or less/02160 or more)	✓	—	✓	
						9999					
		463	Second motor auto tuning setting/status	1	0	0/1/101	Set the tuning mode of the second motor. (same as Pr. 96)	✓	—	✓	
		684	Tuning data unit switchover	1	0	0	Internal data converter value	✓	✓	✓	
						1	Displayed in "A, Ω, mH, %"				
		859	Torque current	0.01A/ 0.1A *	9999	0–500A/ 0–3600A *	Tuning data (The value measured by offline auto tuning is automatically set.) * The increments and setting range differ according to the inverter capacity. (01800 or less/02160 or more)	✓	—	✓	
						9999					
		860	Second motor torque current	0.01A/ 0.1A *	9999	0–500A/ 0–3600A *	Tuning data of the second motor (The value measured by offline auto tuning is automatically set.) * The increments and setting range differ according to the inverter capacity. (01800 or less/02160 or more)	✓	—	✓	
9999	Use the Mitsubishi motor (SF-JR, SF-HRCA) constants										

Tab. 6-1: Parameter overview (26)

Function	Parameter	Name	Increments	Initial Value	Setting Range	Description	Parameter copy	Parameter clear	All parameter clear	Refer to page
							✓: enabled —: disabled			
—	89	Refer to Pr. 81								
	90 - 94	Refer to Pr. 82 to 84								
Online auto tuning Vector Sensorless Magnetic flux	95	Online auto tuning selection	1	0	0	Online auto tuning selection	✓	✓	✓	6-236
					1	Start-time tuning (at start-up)				
2					Magnetic flux observer (normal)					
	574	Second motor online auto tuning	1	0	0/1	Select the second motor online auto tuning. (same as Pr. 95)	✓	✓	✓	
—	96	Refer to Pr. 82 to 84								
Adjustable 5 points V/f V/F	100	V/f1 (first frequency)	0.01Hz	9999	0-400Hz/ 9999	Set each points (frequency, voltage) of V/f pattern. 9999: No V/f setting	✓	✓	✓	6-181
	101	V/f1 (first frequency voltage)	0.1V	0V	0-1000V		✓	✓	✓	
	102	V/f2 (second frequency)	0.01Hz	9999	0-400Hz/ 9999		✓	✓	✓	
	103	V/f2 (second frequency voltage)	0.1V	0V	0-1000V		✓	✓	✓	
	104	V/f3 (third frequency)	0.01Hz	9999	0-400Hz/ 9999		✓	✓	✓	
	105	V/f3 (third frequency voltage)	0.1V	0V	0-1000V		✓	✓	✓	
	106	V/f4 (fourth frequency)	0.01Hz	9999	0-400Hz/ 9999		✓	✓	✓	
	107	V/f4 (fourth frequency voltage)	0.1V	0V	0-1000V		✓	✓	✓	
	108	V/f5 (fifth frequency)	0.01Hz	9999	0-400Hz/ 9999		✓	✓	✓	
	109	V/f5 (fifth frequency voltage)	0.1V	0V	0-1000V		✓	✓	✓	
	71	Refer to page 6-15								
—	110 111	Refer to Pr. 7								
	112	Refer to Pr. 0								
	113	Refer to Pr. 3								
	114 115	Refer to Pr. 22								
	116	Refer to Pr. 41								

Tab. 6-1: Parameter overview (27)

Function	Parameter Related parameters	Name	Increments	Initial Value	Setting Range	Description	Parameter copy	Parameter clear	All parameter clear	Refer to page
							✓: enabled —: disabled			
Communication initial setting	117	PU communication station	1	0	0–31	Specify the inverter station number. Set the inverter station numbers when two or more inverters are connected to one personal computer.	✓	✓	✓	6-448
	118	PU communication speed	1	192	48/96/192/384	Set the communication speed. The setting value × 100 equals the communication speed. For example, the communication speed is 19200bps when the setting value is "192".	✓	✓	✓	
	119	PU communication stop bit length.	1	1	0	Stop bit length: 1bit data length: 8bit	✓	✓	✓	
					1	Stop bit length: 2bit data length: 8bit				
					10	Stop bit length: 1bit data length: 7bit				
					11	Stop bit length: 2bit data length: 7bit				
	120	PU communication parity check	1	2	0	Without parity check	✓	✓	✓	
					1	With odd parity check				
					2	With even parity check				
	121	Number of PU communication retries	1	1	0–10	Set the permissible number of retries at occurrence of a data receive error. If the number of consecutive errors exceeds the permissible value, the inverter will come to an alarm stop.	✓	✓	✓	
					9999	If a communication error occurs, the inverter will not come to an alarm stop.				
	122	PU communication check time interval	0.1s	9999	0	No PU connector communication	✓	✓	✓	
					0.1–999.8s	Set the communication check time interval. If a no-communication state persists for longer than the permissible time, the inverter will come to an alarm stop.				
9999					No communication check					
123	PU communication waiting time setting	1	9999	0–150ms	Set the waiting time between data transmission to the inverter and response.	✓	✓	✓		
				9999	Set with communication data.					

**Tab. 6-1:** Parameter overview (28)

Function	Parameter Related parameters	Name	Increments	Initial Value	Setting Range	Description	Parameter copy	Parameter clear	All parameter clear	Refer to page
							✓: enabled —: disabled			
Communication initial setting	124	PU communication CR/LF presence/absence selection	1	1	0	Without CR/LF	✓	✓	✓	6-448
					1	With CR				
					2	With CR/LF				
	331	RS-485 communication station	1	0	0-31 (0-247)	Set the inverter station number. (same specifications as Pr.117 ) When "1" (Modbus-RTU protocol) is set in Pr.549, the setting range within parenthesis is applied.	✓	✓	✓	
	332	RS-485 communication speed	1	96	3/6/12/24/48/96/192/384	Used to select the communication speed. (same specifications as Pr. 118)	✓	✓	✓	
	333	RS-485 communication stop bit length	1	1	0/1/10/11	Select stop bit length and data length. (same specifications as Pr. 119)	✓	✓	✓	
	334	RS-485 communication parity check selection	1	2	0/1/2	Select the parity check specifications. (same specifications as Pr. 120)	✓	✓	✓	
	335	RS-485 communication retry count	1	1	0-10/9999	Set the permissible number of retries at occurrence of a data receive error. (same specifications as Pr. 121)	✓	✓	✓	
	336	RS-485 communication check time interval	0.1s	0s	0	RS-485 communication can be made, but the inverter will come to an alarm stop in the NET operation mode.	✓	✓	✓	
					0.1-9998s	Set the communication check time interval. (same specifications as Pr. 122)				
					9999	No communication check				
	337	RS-485 communication waiting time setting	1	9999	0-150ms/9999	Set the waiting time between data transmission to the inverter and response. (same specifications as Pr. 123)	✓	✓	✓	
	341	RS-485 communication CR/LF selection	1	1	0/1/2	Select presence/absence of CR/LF. (same specifications as Pr. 124)	✓	✓	✓	
	342	Communication EEPROM write selection	1	0	0	Parameter values written by communication are written to the EEPROM and RAM.	✓	✓	✓	
					1	Parameter values written by communication are written to the RAM.				
	343	Communication error count	1	0	Read only	Display the number of communication errors during Modbus-RTU communication. Read only. Displayed only when Modbus-RTU protocol is selected.	—	—	—	
	539	Modbus-RTU communication check time interval	0.1s	9999	0	Modbus-RTU communication can be made, but the inverter will come to an alarm stop in the NET operation mode.	✓	✓	✓	
0.1-999.8					Set the interval of communication check time. (same specifications as Pr. 122)					
9999					No communication check (signal loss detection)					
549	Protocol selection	1	0	0	Mitsubishi inverter (computer link) protocol	✓	✓	✓		
				1	Modbus-RTU protocol					

Tab. 6-1: Parameter overview (29)

Function	Parameter	Name	Increments	Initial Value	Setting Range	Description	Parameter copy	Parameter clear	All parameter clear	Refer to page		
							✓: enabled —: disabled					
Change of analog input frequency, adjustment of voltage, current input and frequency (calibration)	125	⊙	Terminal 2 frequency setting gain frequency	0.01Hz	50Hz	0–400Hz	Set the frequency of terminal 2 input gain (maximum).	✓	—	✓	6-385	
	126	⊙	Terminal 4 frequency setting gain frequency	0.01Hz	50Hz	0–400Hz	Set the frequency of terminal 4 input gain (maximum). (Valid when Pr. 858 = 0 (initial value))	✓	—	✓		
	241		Analog input display unit switch over	1	0	0	Displayed in %	Select the unit for analog input display.	✓	✓		✓
						1	Displayed in V/mA					
	C2 (902)		Terminal 2 frequency setting bias frequency	0.01Hz	0Hz	0–400Hz	Set the frequency on the bias side of terminal 2 input.	✓	—	✓		
	C3 (902)		Terminal 2 frequency setting bias	0.1%	0%	0–300%	Set the converted % of the bias side voltage (current) of terminal 2 input.	✓	—	✓		
	C4 (903)		Terminal 2 frequency setting gain	0.1%	100%	0–300%	Set the converted % of the gain side voltage of terminal 2 input.	✓	—	✓		
	C5 (904)		Terminal 4 frequency setting bias frequency	0.01Hz	0Hz	0–400Hz	Set the frequency on the bias side of terminal 4 input. (Valid when Pr. 858 = 0 (initial value))	✓	—	✓		
	C6 (904)		Terminal 4 frequency setting bias	0.1%	20%	0–300%	Set the converted % of the bias side current (voltage) of terminal 4 input. (Valid when Pr. 858 = 0 (initial value))	✓	—	✓		
C7 (905)		Terminal 4 frequency setting gain	0.1%	100%	0–300%	Set the converted % of the gain side current (voltage) of terminal 4 input. (Valid when Pr. 858 = 0 (initial value))	✓	—	✓			

Tab. 6-1: Parameter overview (30)

Funktion	Parameter	Steht in Beziehung zu Pr.	Bedeutung	Schrittweite	Werkeinstellung	Einstellbereich	Beschreibung	Parameter kopieren	Parameter löschen	Alle Parameter löschen	Ref.-seite	
								✓: möglich —: nicht möglich				
PID operation	127		PID control automatic switchover frequency	0,01 Hz	9999	0–400 Hz	Set the frequency at which the control is automatically changed to PID control.	✓	✓	✓	6-491	
						9999	Without PID automatic switchover function					
	128			PID action selection	1	10	10	PID reverse action Deviation value signal input (terminal 1 )	✓	✓		✓
							11	PID forward action				
							20	PID reverse action Measured value (terminal 4 )				
							21	PID forward action Set point (terminal 2 or Pr. 133)				
							50	PID reverse action Deviation value signal input LONWORKS , CC-Link communication)				
							51	PID forward action				
							60	PID reverse action Measured value, set point input LONWORKS , CC-Link communication)				
							61	PID forward action				
							70	PID reverse action Deviation value signal input (PLC function)				
							71	PID forward action				
							80	PID reverse action Measured value, set point input (PLC function)				
							81	PID forward action				
							90	PID reverse action Deviation value signal input (PLC function) (Not reflected to the inverter frequency)				
							91	PID forward action				
							100	PID reverse action Measured value, set point input (PLC function) (Not reflected to the inverter frequency)				
							101	PID forward action				

Tab. 6-1: Parameter overview (31)

Function	Parameter	Name	Increments	Initial Value	Setting Range	Description	Parameter copy	Parameter clear	All parameter clear	Refer to page
							✓: enabled —: disabled			
PID control	129	PID proportional band	0.1%	100%	0.1–1000%	If the proportional band is narrow (parameter setting is small), the manipulated variable varies greatly with a slight change of the measured value. Hence, as the proportional band narrows, the response sensitivity (gain) improves but the stability deteriorates, e.g. hunting occurs. Gain $K = 1/\text{proportional band}$	✓	✓	✓	6-491
					9999	No proportional control.				
	130	PID integral time	0.1s	1s	0.1–3600s	Time required for only the integral (I) action to provide the same manipulated variable as that for the proportional (P) action. As the integral time decreases, the set point is reached earlier but hunting occurs more easily.	✓	✓	✓	
					9999	No integral control.				
	131	PID upper limit	0.1%	9999	0–100%	Set the upper limit value. If the feedback value exceeds the setting, the FUP signal is output. The maximum input (20mA/5V/10V) of the measured value (terminal 4) is equivalent to 100%.	✓	✓	✓	
					9999	No function				
	132	PID lower limit	0.1%	9999	0–100%	Set the lower limit value. If the process value falls below the setting range, the FDN signal is output. The maximum input (20mA/5V/10V) of the measured value (terminal 4) is equivalent to 100%.	✓	✓	✓	
					9999	No function				
	133	PID action set point	0.01%	9999	0–100%	Used to set the set point for PID control in the PU operation mode.	✓	✓	✓	
					9999	Terminal 2 input voltage is the set point.				
	134	PID differential time	0.01s	9999	0.01–10.00s	Time required for only the differential (D) action to provide the same manipulated variable as that for the proportional (P) action. As the differential time increases, greater response is made to a deviation change.	✓	✓	✓	
					9999	No differential control.				
	575	Output interruption detection time	0.1s	1s	0–3600s	If the output frequency after PID operation remains lower than the Pr. 576 setting for longer than the time set in Pr. 575, the inverter stops operation.	✓	✓	✓	
					9999	Without output interruption function				
576	Output interruption detection level	0.01Hz	0Hz	0–400Hz	Set the frequency at which the output interruption processing is performed.	✓	✓	✓		
577	Output interruption release level	0.1%	1000%	900–1100%	Set the level (Pr. 577 minus 1000%) to release the PID output interruption function.	✓	✓	✓		

Tab. 6-1: Parameter overview (32)



Function	Parameter	Name	Increments	Initial Value	Setting Range	Description	Parameter copy	Parameter clear	All parameter clear	Refer to page
							✓: enabled —: disabled			
Switch between the inverter operation and commercial power-supply operation	135	Commercial power-supply switchover sequence output terminal selection	1	0	0	Without commercial power-supply switchover sequence	✓	✓	✓	6-505
					1	With commercial power-supply switchover sequence				
	136	MC switchover interlock time	0.1s	1s	0–100s	Set the operation interlock time of MC2 and MC3.	✓	✓	✓	
	137	Start waiting time	0.1s	0.5s	0–100s	Set the time slightly longer (0.3 to 0.5s or so) than the time from when the ON signal enters MC3 until it actually turns on.	✓	✓	✓	
	138	Commercial power-supply operation switchover selection at an alarm	1	0	0	Inverter output is stopped (motor coast) at inverter fault.	✓	✓	✓	
					1	Operation is automatically switched to the commercial power-supply operation at inverter fault. (Not switched when an external thermal error occurs.)				
	139	Automatic switchover frequency between inverter and commercial power-supply operation	0.01Hz	9999	0–60Hz	Set the frequency to switch the inverter operation to the commercial power-supply operation.	✓	✓	✓	
					9999	Without automatic switchover				
	159	Automatic switchover ON range between commercial power-supply and inverter operation	0.01Hz	9999	0–10Hz	Valid during automatic switchover operation (Pr.139 ≠ 9999) When the frequency command decreases below (Pr. 139 to Pr. 159) after operation is switched from inverter operation to commercial power-supply operation, the inverter automatically switches operation to the inverter operation and operates at the frequency of frequency command. When the inverter start command (STF/STR) is turned off, operation is switched to the inverter operation also.	✓	✓	✓	
					9999	Valid during automatic switchover operation (Pr.139 ≠ 9999) When the inverter start command (STF/STR) is turned off after operation is switched from the inverter operation to commercial power-supply inverter operation, operation is switched to the inverter operation and the motor decelerates to stop.				
—	140–143	Refer to Pr. 29								
	144	Refer to Pr. 37								

**Tab. 6-1:** Parameter overview (33)

Function	Parameter	Name	Increments	Initial Value	Setting Range	Description	Parameter copy	Parameter clear	All parameter clear	Refer to page	
							✓: enabled —: disabled				
Parameter unit language switchover	145	PU display language selection	1	1	0	Japanese	✓	—	—	6-541	
					1	English					
					2	German					
					3	French					
					4	Spanish					
					5	Italian					
					6	Swedish					
7	Finnish										
—	148 149	Refer to Pr. 22									
Detection of output current (Y12 signal) and Detection of zero current (Y13 signal)	150	Output current detection level	0.1%	150%	0–220%	Set the output current detection level. 100% is the rated inverter current.	✓	✓	✓	6-315	
	151	Output current detection signal delay time	0.1s	0s	0–10s	Set the output current detection period. Set the time from when the output current has risen above the setting until the output current detection signal (Y12) is output.	✓	✓	✓		
	152	Zero current detection level	0.1%	5%	0–220%	Set the zero current detection level. Suppose that the rated inverter current at the specified overload capacity is 100%.	✓	✓	✓		
	153	Zero current detection time	0.01s	0.5s	0–1s	Set this parameter to define the period from when the output current drops below the Pr. 152 value until the zero current detection signal (Y13) is output.	✓	✓	✓		
		166	Output current detection signal retention time	0.1s	0.1s	0–10s	Set the retention time when the Y12 signal is on.	✓	✓		✓
						9999	The Y12 signal on status is retained. The signal is turned off at the next start.				
	167	Output current detection operation selection	1	0	0	Operation continues when the Y12 signal is on.	✓	✓	✓		
1					The inverter is brought to an alarm stop when the Y12 signal is on. (E.CDO)						
—	154	Refer to Pr. 22									
Selection of action conditions of the second function	155	RT signal reflection time selection	1	0	0	Second function is immediately made valid with on of the RT (X9) signal.	✓	✓	✓	6-295	
					10	Second function is valid only during the RT signal is on and constant speed operation. (Invalid during acceleration/deceleration)					
—	156 157	Refer to Pr. 22									
	158	Refer to Pr. 54									
	159	Refer to Pr. 135									

Tab. 6-1: Parameter overview (34)

Function	Parameter	Name	Increments	Initial Value	Setting Range	Description	Parameter copy	Parameter clear	All parameter clear	Refer to page	
							✓: enabled —: disabled				
User group function	160	⊙ User group read selection	1	9999	0	Simple mode and extended mode parameters can be displayed.	✓	✓	✓	6-415	
					1	Only parameters registered in the user group can be displayed.					
					9999	Only the simple mode parameters can be displayed.					
	172	User group registered display/batch clear	1	0	(0-16)	Displays the number of cases registered as a user group (reading only).	✓	—	—		
					9999	Batch clear the user group registration					
	173	User group registration	1	9999	0-999/9999	Set the parameter numbers to be registered to the user group. Read value is always "9999".	—	—	—		
174	User group clear	1	9999	0-999/9999	Set the parameter numbers to be cleared from the user group. Read value is always "9999".	—	—	—			
Operation selection of the operation panel	161	Frequency setting/key lock operation selection	1	0	0	Setting dial frequency setting mode	✓	—	✓	6-542	
					1	Setting dial potentiometer mode					Key lock mode invalid
					10	Setting dial frequency setting mode					Key lock mode valid
					11	Setting dial potentiometer mode					
—	162 — 165	Refer to Pr. 57									
	166 167	Refer to Pr. 150									
	168 169	Parameter for manufacturer setting. Do not set.									
	170 171	Refer to Pr. 52									
	172 — 174	Refer to Pr. 160									

**Tab. 6-1:** Parameter overview (35)

Function	Parameter	Name	Increments	Initial Value	Setting Range	Description	Parameter copy	Parameter clear	All parameter clear	Refer to page
							✓: enabled —: disabled			
Function assignment of input terminal	178	STF terminal function selection	1	60	0-20/ 22-28/37/ 42-44/50/ 60/62/ 64-71/74/ 9999	0: Low-speed operation command 1: Middle-speed operation command 2: High-speed operation command	✓	—	✓	6-289
	179	STR terminal function selection	1	61	0-20/ 22-28/37/ 42-44/50/ 61/62/ 64-71/74/ 9999	3: Second function selection 4: Terminal 4 input selection 5: Jog operation selection 6: Selection of automatic restart after instantaneous power failure	✓	—	✓	
	180	RL terminal function selection	1	0	0-20/ 22-28/37/ 42-44/50/ 62/64-71/ 74/9999	7: External thermal relay input 8: Fifteen speed selection 9: Third function 10: Inverter operation enable signal (FR-HC, MT-HC, FR-CV connection)	✓	—	✓	
	181	RM terminal function selection	1	1		11: FR-HC, MT-HC connection, instantaneous power failure detection	✓	—	✓	
	182	RH terminal function selection	1	2		12: PU operation external interlock 13: External DC injection brake start 14: PID control valid terminal 15: Brake opening completion signal	✓	—	✓	
	183	RT terminal function selection	1	3		16: PU-external operation switchover 17: Load pattern selection forward/reverse rotation boost	✓	—	✓	
	184	AU terminal function selection	1	4		18: V/f switch over 19: Load torque high-speed frequency 20: S-pattern acceleration/deceleration C switching terminal	✓	—	✓	
	185	JOG terminal function selection	1	5	0-20/ 22-28/37/ 42-44/50/ 62-71/74/ 9999	22: Orientation command 23: Pre-excitation 24: Output stop 25: Start self-holding selection	✓	—	✓	
	186	CS terminal function selection	1	6		26: Control mode changing 27: Torque limit selection 28: Start time tuning 37: Traverse function selection	✓	—	✓	
	187	MRS terminal function selection	1	24		42: Torque bias selection 1 * 43: Torque bias selection 2 * 44: P/PI control switchover 50: Sequence start	✓	—	✓	
	188	STOP terminal function selection	1	25		60: Forward rotation command (assigned to STF terminal (Pr. 178) only) 61: Reverse rotation command (assigned to STR terminal (Pr. 179) only)	✓	—	✓	
189	RES terminal function selection	1	62	0-20/ 22-28/37/ 42-44/50/ 62/64-71/ 74/9999	62: Inverter reset 63: PTC thermistor input (assigned to AU terminal (Pr. 184) only) 64: PID forward/reverse action switchover 65: NET/PU operation switchover 66: External/NET operation switchover 67: Command source switchover 68: Conditional position pulse train sign * 69: Conditional position droop pulse clear * 70: DC feeding operation permission 71: DC feeding cancel 74: Magnetic flux decay output shutoff 9999: No function * Available only when used with the FR-A7AP.	✓	—	✓		

Tab. 6-1: Parameter overview (36)

Function	Parameter	Name	Increments	Initial Value	Setting Range	Description	Parameter copy	Parameter clear	All parameter clear	Refer to page
							✓: enabled —: disabled			
Function assignment of output terminal	190	RUN terminal function selection	1	0	0–5/7/8/ 10–19/25/ 26/45–47/ 55/64/ 70–78/ 90–96/ 98/99/ 100–105/ 107/108/ 110–116/ 125/126/ 145–147/ 155/164/ 170/ 190–196/ 198/199/ 9999	0/100: Inverter running 1/101: Up to frequency 2/102: Instantaneous power failure/under voltage 3/103: Overload alarm 4/104: Output frequency detection 5/105: Second output frequency detection 6/106: Third output frequency detection 7/107: Regenerative brake prealarm (≥ 01800) 8/108: Electronic thermal relay function prealarm 10/110: PU operation mode 11/111: Inverter operation ready 12/112: Output current detection 13/113: Zero current detection 14/114: PID lower limit 15/115: PID upper limit 16/116: PID forward/reverse rotation output 17/–: Commercial power-supply switchover MC1 18/–: Commercial power-supply switchover MC2 19/–: Commercial power-supply switchover MC3 20/120: Brake opening request 25/125: Fan fault output 26/126: Heatsink overheat prealarm 27/127: Orientation in-position * 28/128: Orientation error * 30/130: Forward rotation output * 31/131: Reverse rotation output * 32/132: Regenerative status output * 33/133: Operation ready 2 34/134: Low speed output 35/135: Torque detection 36/136: In-position * 39/139: Start time tuning completion 41/141: Speed detection 42/142: Second speed detection 43/143: Third speed detection 44/144: Inverter running 2 45/145: Inverter running and start command is on 46/146: During deceleration at occurrence of power failure (retained until release)	✓	—	✓	6-301
	191	SU terminal function selection	1	1		47/147: PID control activated 55/155: Motor temperature detection signal (available with FR-A7AZ only)	✓	—	✓	
	192	IPF terminal function selection	1	2		64/164: During retry 70/170: PID output interruption 84/184: Preparat DC current feeding ready signal * 85/185: DC current feeding 90/190: Life alarm 91/191: Alarm output 3 (power-off signal)	✓	—	✓	
	193	OL terminal function selection	1	3		92/192: Energy saving average value updated timing 93/193: Current average monitor 94/194: Alarm output 2 95/195: Maintenance timer alarm 96/196: Remote output 97/197: Minor fault output 2 98/198: Minor fault output 99/199: Alarm output 9999: No function	✓	—	✓	
	194	FU terminal function selection	1	4		100–199: Source logic 100–199: Sink logic	✓	—	✓	
	195	ABC1 terminal function selection	1	99		* Available only when used with the FR-A7AP	✓	—	✓	
	196	ABC2 terminal function selection	1	9999			✓	—	✓	

Tab. 6-1: Parameter overview (37)

Function	Parameter Related parameters	Name	Increments	Initial Value	Setting Range	Description	Parameter copy	Parameter clear	All parameter clear	Refer to page
							✓: enabled —: disabled			
—	232 — 239	Refer to Pr. 4 to Pr. 6								
	240	Refer to Pr. 72								
	241	Refer to Pr. 125 and Pr. 126								
	242 243	Refer to Pr. 73								
Increase cooling fan life	244	Cooling fan operation selection	1	1	0	Operates at power on Cooling fan on/off control invalid (The cooling fan is always on at power on.)	✓	✓	✓	6-530
					1	Cooling fan on/off control valid The fan is normally on during inverter operation. The fan switches on/off according to the temperature during a stop of the inverter whose status is monitored.				
Slip compensation 	245	Rated slip	0.01%	9999	0–50%	Used to set the rated motor slip.	✓	✓	✓	6-154
					9999	No slip compensation				
	246	Slip compensation time constant	0.01s	0.5 s	0.01–10s	Used to set the response time of slip compensation. When the value is made smaller, response will be faster. However, as load inertia is greater, a regenerative over voltage (E.OV□) error is more liable to occur.	✓	✓	✓	
						247				
9999	Slip compensation is made in the constant output range.									
Selection of motor stopping method	250	Stop selection	0.1s	9999	0–100s	The motor is coasted to a stop when the preset time elapses after the start signal is turned off. STF signal: Forward rotation start STR signal: Reverse rotation start	✓	✓	✓	6-257
					1000–1100s	The motor is coasted to a stop (Pr. 250 setting – 1000)s after the start signal is turned off. STF signal: Start signal STR signal: Forward/reverse signal				
					8888	When the start signal is turned off, the motor decelerates to stop. STF signal: Start signal STR signal: Forward/reverse signal				
					9999					

Tab. 6-1: Parameter overview (38)

Function	Parameter	Name	Increments	Initial Value	Setting Range	Description	Parameter copy	Parameter clear	All parameter clear	Refer to page
							✓: enabled —: disabled			
Input/output phase failure protection selection	251	Output phase failure protection selection	1	1	0	Without output phase failure protection	✓	✓	✓	6-359
					1	With output phase failure protection				
	872	Input phase failure protection selection	1	0	0	Without input phase failure protection	✓	✓	✓	
					1	With input phase failure protection				
—	252 253	Refer to Pr. 73								
Display of the life of the inverter parts	255	Life alarm status display	1	0	(0–15)	Display whether the control circuit capacitor, main circuit capacitor, cooling fan, and each parts of the inrush current limit circuit has reached the life alarm output level or not.	—	—	—	6-531
	256	Inrush current limit circuit life display	1%	100%	(0–100%)	Display the deterioration degree of the inrush current limit circuit. (Reading only)	—	—	—	
	257	Control circuit capacitor life display	1%	100%	(0–100%)	Display the deterioration degree of the control circuit capacitor. (Reading only)	—	—	—	
	258	Main circuit capacitor life display	1%	100%	(0–100%)	Display the deterioration degree of the main circuit capacitor. (Reading only) The value measured by Pr. 259 is displayed.	—	—	—	
	259	Main circuit capacitor life measuring	1	0	0/1	Setting "1" and turning the power supply off starts the measurement of the main circuit capacitor life. When the Pr. 259 value is "3" after powering on again, the measuring is completed. Read the deterioration degree in Pr. 258.	✓	✓	✓	
—	260	Refer to Pr. 72								

**Tab. 6-1:** Parameter overview (39)

Function	Parameter	Name	Increments	Initial Value	Setting Range	Description	Parameter copy	Parameter clear	All parameter clear	Refer to page	
							✓: enabled —: disabled				
Decelerate the motor to a stop at instantaneous power failure	261	Power failure stop selection	1	0	0	Coasting to stop When under voltage or power failure occurs, the inverter output is shut off.	✓	✓	✓	6-349	
					1	Without UV avoidance					When under voltage or a power failure occurs, the inverter can be decelerated to a stop.
					11	With UV avoidance					When under voltage or a power failure occurs, the inverter can be decelerated to a stop.
					2	Without UV avoidance					When under voltage or a power failure occurs, the inverter can be decelerated to a stop. If power is restored during a power failure, the inverter accelerates again.
					12	With UV avoidance					When under voltage or a power failure occurs, the inverter can be decelerated to a stop. If power is restored during a power failure, the inverter accelerates again.
	262	Subtracted frequency at deceleration start	0.01Hz	3Hz	0–20Hz	Normally operation can be performed with the initial value unchanged. But adjust the frequency according to the magnitude of the load specifications (moment of inertia, torque).	✓	✓	✓		
	263	Subtraction starting frequency	0.01Hz	50Hz	0–120Hz	When output frequency ≥ Pr. 263 Decelerate from the speed obtained from output frequency minus Pr. 262. When output frequency < Pr. 263 Decelerate from output frequency	✓	✓	✓		
					9999	Decelerate from the speed obtained from output frequency minus Pr. 262.	✓	✓	✓		
	264	Power-failure deceleration time 1	0.1/0.01s	5s	0–3600/360s	Set a deceleration slope down to the frequency set in Pr. 266.	✓	✓	✓		
	265	Power-failure deceleration time 2	0.1/0.01s	9999	0–3600/360s	Set a deceleration slope below the frequency set in Pr. 266.	✓	✓	✓		
9999					Same slope as in Pr. 264						
266	Power failure deceleration time switchover frequency	0.01Hz	50Hz	0–400Hz	Set the frequency at which the deceleration slope is switched from the Pr. 264 setting to the Pr. 265 setting.	✓	✓	✓			
	294	UV avoidance voltage gain	0.1%	100%	0–200%	Adjust response level at UV avoidance operation. A larger setting will improve responsiveness to the bus voltage change. Since the regeneration amount is large when the inertia is large, decrease the setting value.	✓	✓	✓		
—	267	Refer to Pr. 73									
	268	Refer to Pr. 52									
	269	Parameter for manufacturer setting: Do not set!									

Tab. 6-1: Parameter overview (40)



Function	Parameter	Name	Increments	Initial Value	Setting Range	Description	Parameter copy	Parameter clear	All parameter clear	Refer to page	
							✓: enabled —: disabled				
Load torque high speed frequency control	270	Stop-on contact/load torque high-speed frequency control selection	1	0	0	Without stop-on contact control and load torque high-speed frequency control	✓	✓	✓	6-259	
					1	Stop-on contact control					
					2	Load torque high speed frequency control					
					3	Stop-on contact + load torque high speed frequency control					
					11	Stop-on contact control					E.OLT detection is inactive during stop-on-contact control
					13	Stop-on contact + load torque high speed frequency control					
	271	High-speed setting maximum current	0.1%	50%	0-220%	Set the upper and lower limits of the current at high and middle speeds.	✓	✓	✓		
	272	Middle-speed setting minimum current	0.1%	100%	0-220%		✓	✓	✓		
273	Current averaging range	0.01Hz	9999	0-400Hz	Average current during acceleration from (Pr. 273 × 1/2)Hz to (Pr. 273 )Hz can be achieved	✓	✓	✓			
				9999	Average current during acceleration from (Pr. 5 × 1/2)Hz to (Pr. 5)Hz is achieved.						
274	Current averaging filter time constant	1	16	1-4000	Set the time constant of the primary delay filter relative to the output current. (The time constant [ms] is 0.75 × Pr. 274 and the initial value is 12ms.) A larger setting provides higher stability but poorer response.	✓	✓	✓			
Stop-on contact control	270	Stop-on contact/load torque high-speed frequency control selection	1	0	0	Without stop-on contact control and load torque high-speed frequency control	✓	✓	✓	6-512	
					1	Stop-on contact control					
					2	Load torque high speed frequency control					
					3	Stop-on contact + load torque high speed frequency control					
					11	Stop-on contact control					E.OLT detection is inactive during stop-on contact control
					13	Stop-on contact + load torque high speed frequency control					
	275	Stop-on contact excitation current low-speed multiplying factor	0.1%	9999	0-1000%	Usually set a value between 130% and 180%. Set the force (holding torque) for stop-oncontact control.	✓	✓	✓		
					9999	No compensation.					
276	PWM carrier frequency at stop-on contact	1	9999	0-9/ 0-4 *	Set a PWM carrier frequency for stop-oncontact control. (Valid at the output frequency of 3Hz or less.) * The setting range differs according to the inverter capacity. (01800 or less/02160 or more)	✓	✓	✓			
				9999	As set in Pr. 72 "PWM frequency selection".						

Tab. 6-1: Parameter overview (41)

Function	Parameter	Name	Increments	Initial Value	Setting Range	Description	Parameter copy	Parameter clear	All parameter clear	Refer to page
							✓: enabled —: disabled			
Brake sequence function Vector Sensorless Magnetic flux	278	Brake opening frequency	0.01Hz	3Hz	0–30Hz	Set to the rated slip frequency of the motor + about 1.0Hz. This parameter may be only set if Pr. 278 ≤ Pr. 282.	✓	✓	✓	6-264
	279	Brake opening current	0.1%	130%	0–220%	Generally, set this parameter to about 50 to 90%. If the setting is too low, the load is liable to drop due to gravity at start. Suppose that the rated inverter current is 100%.	✓	✓	✓	
	280	Brake opening current detection time	0.1s	0.3s	0–2s	Generally, set this parameter to about 0.1 to 0.3s.	✓	✓	✓	
	281	Brake operation time at start	0.1s	0.3s	0–5s	Pr. 292 = 7: Set the mechanical delay time until the brake is loosened. Pr. 292 = 8: Set the mechanical delay time until the brake is loosened + about 0.1 to 0.2s.	✓	✓	✓	
	282	Brake operation frequency	0.01Hz	6Hz	0–30Hz	At this frequency, the brake opening request signal (BOF) is switched off. Generally, set this parameter to the Pr. 278 setting + 3 to 4Hz. Setting is enabled only when Pr. 278 ≤ Pr. 282.	✓	✓	✓	
	283	Brake operation time at stop	0.1s	0.3s	0–5s	Pr. 292 = 7: Set the mechanical delay time until the brake is closed + 0.1s. Pr. 292 = 8: Set the mechanical delay time until the brake is closed + about 0.2 to 0.3s.	✓	✓	✓	
	284	Deceleration detection function selection	1	0	0	Deceleration is not detected.	✓	✓	✓	
					1	If deceleration is not normal during deceleration operation, the inverter alarm (E.MB2) is provided to shut off the output and turn off the brake opening request signal (BOF).				
285	Excessive speed deviation detection frequency	0.01Hz	9999	0–30Hz	When brake sequence function is made valid under encoder feedback control If (detected frequency) – (output frequency) > Pr 285 under encoder feedback control, the inverter alarm (E.MB1) is provided to shut off the output and turn off the brake opening request signal (BOF). Overspeed is not detected.	✓	✓	✓		
					Automatic acceleration/deceleration				1	0
Speed deviation excess detection Vector	285	Speed deviation excess detection frequency	0.01Hz	9999	9999	Without speed deviation excessive	✓	✓	✓	6-107
					0–30Hz	If the difference (absolute value) between the speed command value and actual speed exceeds the Pr. 285 "Speed deviation excess detection frequency" setting for longer than the time set in Pr. 853 "Speed deviation time" during speed control under vector control, speed deviation excessive occurs and error "E. OSD" appears, resulting in a stop.				
	853	Speed deviation time	0.1s	1s	0–100s		✓	✓	✓	

Tab. 6-1: Parameter overview (42)

Function	Parameter	Name	Increments	Initial Value	Setting Range	Description	Parameter copy	Parameter clear	All parameter clear	Refer to page	
							✓: enabled —: disabled				
Droop-Steuerung <div style="display: flex; flex-direction: column; align-items: center;"> <div style="border: 1px solid black; padding: 2px; margin-bottom: 2px;">Vector</div> <div style="border: 1px solid black; padding: 2px; margin-bottom: 2px;">Sensorless</div> <div style="border: 1px solid black; padding: 2px;">Magnetic flux</div> </div>	286	Droop gain	0.1%	0%	0	Droop control is invalid	✓	✓	✓	6-516	
					0.1–100%	Set the drooping amount at the rated torque as a percentage with respect to the rated frequency.					
	287	Droop filter time constant	0.01 s	0.3s	0–1s	Set the time constant of the primary delay filter applied to the torque current.	✓	✓	✓		
	288	Droop-Funktion aktivieren	1	0	0/10	Real sensorless vector / vector control	Advanced magnetic flux vector control	✓	✓		✓
						Droop control is not exercised during acceleration/ deceleration. (When Pr. 288 = 10, droop compensation amount is determined using the motor speed as reference.)					
						Droop control is always exercised during operation. (with 0 limit) (When Pr.288 = 11, droop compensation amount is determined using the motor speed as reference.)					
				2	Droop control is always exercised during operation. (without 0 limit)						
Pulse train input	291	Pulse train input selection	1	0	0	Terminal JOG	✓	—	✓	6-518	
					1	Pulse train input					
	384	Input pulse division scaling factor	1	0	0–250	Indicates division scaling factor to the input pulse and the frequency resolution to the input pulse changes according to the value.	✓	✓	✓		
	385	Frequency for zero input pulse	0.01Hz	0	0–400Hz	Set the frequency when the input pulse is 0 (bias).	✓	✓	✓		
386	Frequency for maximum input pulse	0.01Hz	50 Hz	0–400Hz	Set the frequency when the input pulse is maximum (gain).	✓	✓	✓			

Tab. 6-1: Parameter overview (43)

Function	Parameter	Name	Increments	Initial Value	Setting Range	Description	Parameter copy	Parameter clear	All parameter clear	Refer to page
							✓: enabled —: disabled			
—	292 293	Refer to Pr. 61								
—	294	Refer to Pr. 261								
—	299	Refer to Pr. 57								
—	331 — 337	Refer to Pr. 117								
Communication	338	Communication operation command source	1	0	0	Operation command source communication	✓	✓	✓	6-432
					1	Operation command source external (start/stop)				
	339	Communication speed command source	1	0	0	Speed command source communication	✓	✓	✓	
					1	Speed command source external (Frequency setting from communication is invalid, terminal 2 and 1 setting from external is valid)				
					2	Speed command source external (Frequency setting from communication is valid, terminal 2 and 1 setting from external is invalid)				
	550	NET mode operation command source selection	1	9999	0	Communication option valid	✓	✓	✓	
					1	Inverter RS-485 terminal valid				
					9999	Automatic recognition of the communication option Normally, the RS-485 terminals are valid. Communication option is valid when the communication option is mounted				
	551	PU mode operation command source selection	1	2	1	Select the RS-485 terminals as the PU operation mode control source.	✓	✓	✓	
					2	Select the PU connector as the PU operation mode control source.				
					3	Select the USB connector as the PU operation mode control source.				
	—	340	Refer to Pr. 79							
—	341 — 343	Refer to Pr. 117 to Pr. 124								

**Tab. 6-1:** Parameter overview (44)

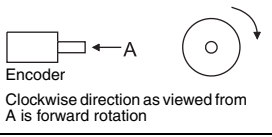
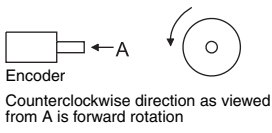
Function	Parameter Related parameters	Name	Increments	Initial Value	Setting Range	Description	Parameter copy	Parameter clear	All parameter clear	Refer to page
							✓: enabled —: disabled			
Orientation control V/F	350	Stop position command selection	1	999	0	Internal stop position command (Pr. 356)	✓	✓	✓	6-269
					1	External stop position command (FR-A7AX 16-bit data)				
					9999	Orientation control invalid				
	351	Orientation speed	0.01Hz	2Hz	0–30Hz	Decrease the motor speed to the set value when the orientation command (X22) is given.	✓	✓	✓	
	352	Creep speed	0.01Hz	0.5Hz	0–10Hz	As soon as the current position pulse reaches the creep switchover position set in Pr. 353 after the speed has reached the orientation command (X22) is given.	✓	✓	✓	
	353	Creep switchover position	1	511	0–16383	As soon as the current position pulse reaches the creep switchover position set in Pr. 353 after the speed has reached the orientation command (X22) is given, the speed decelerates down to the creep speed set in Pr. 352.	✓	✓	✓	
	354	Position loop switchover position	1	96	0–8191	As soon as the current position pulse reaches the set position loop switchover position, control is changed to position loop.	✓	✓	✓	
	355	DC injection brake start position	1	5	0–255	After changed to position loop, DC injection brake is applied and the motor stops as soon as the current position pulse reaches the set DC injection brake start position.	✓	✓	✓	
	356	Internal stop position command	1	0	0–16383	When "0" is set in Pr. 350, the internal position command is activated and the setting value of Pr. 356 becomes a stop position.	✓	✓	✓	
	357	In-position zone	1	5	0–255	Set the in-position zone at a stop of the orientation.	✓	✓	✓	
	358	Servo torque selection	1	1	0–13	Functions at orientation completion can be selected.	✓	✓	✓	
359	Encoder rotation direction	1	1	0	 <p>Encoder Clockwise direction as viewed from A is forward rotation</p>	✓	✓	✓		
				1	 <p>Encoder Counterclockwise direction as viewed from A is forward rotation</p>					

Tab. 6-1: Parameter overview (45)

Function	Parameter	Name	Increments	Initial Value	Setting Range	Description	Parameter copy	Parameter clear	All parameter clear	Refer to page
							✓: enabled —: disabled			
Orientation control	360	16 bit data selection	1	0	0	Speed command	✓	✓	✓	6-269
					1	Position command 16 bit data is used as external position command as is.				
					2-127	Set the stop position dividing up to 128 stop positions at regular intervals.				
	361	Position shift	1	0	0-16383	Shift the origin using a compensation value without changing the origin of the encoder. The stop position is a position obtained by adding the setting value of Pr. 361 to the position command.	✓	✓	✓	
	362	Orientation position loop gain	0.1	1	0.1-100	When servo torque function is selected using Pr. 358, output frequency for generating servo torque increases to the creep speed of Pr. 352 gradually according to the slope set in Pr. 362. Although the operation becomes faster when the value is increased, a machine may hunt, etc..	✓	✓	✓	
	363	Completion signal output delay time	0.1s	0.5s	0-5s	The orientation complete signal (ORA) is output delaying the set time after in-position zone is entered. Also, the signal turns off delaying the set time after in-position zone is out.	✓	✓	✓	
	364	Encoder stop check time	0.1s	0.5s	0-5s	Orientation fault signal (ORM) is output when the encoder remains stopped for the set time without orientation completion in the state where no orientation complete signal (ORA) is output. ORM signal is output when orientation is not completed again in the set time in the state where ORA signal is output.	✓	✓	✓	
365	Orientation limit	1s	9999	0-60s	Measure the time taken after passing the creep switchover position and output the orientation fault signal (ORM) if orientation is not completed within the set time.	✓	✓	✓		
				9999	Set to 120s.					

Tab. 6-1: Parameter overview (46)

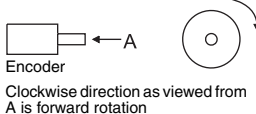
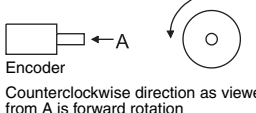
Function	Parameter	Name	Increments	Initial Value	Setting Range	Description	Parameter copy	Parameter clear	All parameter clear	Refer to page
							✓: enabled —: disabled			
Orientation control Vector Magnetic flux V/F	366	Recheck time	0.1s	9999	0-5s	Turning off the start signal with orientation command (X22) on after stopping the motor by orientation control, the present position is checked again after the set time elapses and the orientation complete signal (ORA) or orientation fault signal (ORM) is output.	✓	✓	✓	6-269
					9999	Not checked.				
	369	Number of encoder pulses	1	1024	0-4096	Set the number of pulses of the encoder. Set the number of pulses before multiplied by four.	✓	✓	✓	
	393	Orientation selection	1	0	0	Orientation is executed from the current rotation direction.	✓	✓	✓	
					1	Orientation is executed from the forward rotation direction.				
					2	Orientation is executed from the reverse rotation direction.				
	396	Orientation speed gain (P term)	1	60	0-1000	Servo rigidity is (response level during position control loop) at orientation stop can be adjusted.	✓	✓	✓	
	397	Orientation speed integral time	0.001s	0.333s	0-20.0 s		✓	✓	✓	
398	Orientation speed gain (D term)	0.1%	1%	0-100.0%	Lag/advance compensation gain can be adjusted.	✓	✓	✓		
399	Orientation deceleration ratio	1	20	0-1000	Make adjustment when the motor runs back at orientation stop or the orientation time is long.	✓	✓	✓		
Encoder feedback control Magnetic flux V/F	359	Encoder rotation direction	1	1	0	 Encoder Clockwise direction as viewed from A is forward rotation	✓	✓	✓	6-527
					1	 Encoder Counterclockwise direction as viewed from A is forward rotation				
	367	Speed feedback range	0.01Hz	9999	0-400Hz	Set the region of speed feedback control.	✓	✓	✓	
					9999	Encoder feedback control is invalid				
	368	Feedback gain	0.1	1	0-100	Set when the rotation is unstable or response is slow.	✓	✓	✓	
369	Number of encoder pulses	1	1024	0-4096	Set the number of pulses of the encoder. Set the number of pulses before multiplied by four.	✓	✓	✓		
Overspeed detection	374	Overspeed detection level	0.01Hz	140Hz	0-400Hz	When the motor speed reaches or exceeds the speed set in Pr. 374 during encoder feedback control, real sensorless vector control, or vector control, over speed (E.OS) occurs and stops the inverter output.	✓	✓	✓	6-360

Tab. 6-1: Parameter overview (47)

Function	Parameter	Name	Increments	Initial Value	Setting Range	Description	Parameter copy	Parameter clear	All parameter clear	Refer to page
							✓: enabled —: disabled			
Encoder signal cable breakage detection V/F Magnetic flux Vector	376	Open cable detection enable/disable selection	1	0	0	Signal loss detection is invalid	✓	✓	✓	6-360
					1	Signal loss detection is valid When the cable of the encoder signal is broken during encoder feedback control, orientation control, or vector control, signal loss detection (E.ECT) is activated to stop the inverter output.				
—	380 — 383	Refer to Pr. 29								
	384 — 386	Refer to Pr. 291								
	393 — 399	Refer to Pr. 350 to Pr. 366								
PLC function	414	PLC function operation selection	1	0	0	PLC function is invalid	✓	✓	✓	6-489
					1	PLC function is valid (Inverter reset is necessary to make this setting valid.)				
	415	Inverter operation lock mode setting	1	0	0	The inverter start signal is made valid regardless of the sequence program execution key.	✓	✓	✓	
1					The inverter start signal is made valid only when the sequence program execution key is set to RUN. When the sequence program execution key is in the STOP position, the inverter does not start if the inverter start signal STF or STR is turned on. (If the key is switched from RUN to STOP during inverter operation, the inverter is decelerated to a stop.)					
416	Pre-scale function selection	1	0	0-5	Pre-scale function selection (increments scaling factor) 0: × No function 1: × 1 2: × 0.1 3: × 0.01 4: × 0.001 5: × 0.0001	✓	✓	✓		

Tab. 6-1: Parameter overview (48)



Function	Parameter	Name	Increments	Initial Value	Setting Range	Description	Parameter copy	Parameter clear	All parameter clear	Refer to page
							✓: enabled —: disabled			
PLC function	417	Pre-scale setting value	1	1	0–32767	Set the pre-scale value to calculate the number of sampling pulse when inputting the pulse train.	✓	✓	✓	6-489
		498	Flash-Speicher der integrierten SPS löschen	1	0	0–9999	9696: Flash memory clear Other than 9696: Flash memory is not cleared	—	—	
	506	Parameter 1 for user	1	0	0–65535	Inverter parameters Pr. 506 to Pr. 515 can be used as user parameters. Since this parameter area and the devices used with the PLC function, D110 to D119, are accessible to each other, the values set in Pr. 506 to Pr. 515 can be used in a sequence program. The result of operation performed in the sequence program can also be monitored using Pr. 506 to Pr. 515.	✓	✓	✓	
	507	Parameter 2 for user	1	0	0–65535		✓	✓	✓	
	508	Parameter 3 for user	1	0	0–65535		✓	✓	✓	
	509	Parameter 4 for user	1	0	0–65535		✓	✓	✓	
	510	Parameter 5 for user	1	0	0–65535		✓	✓	✓	
	511	Parameter 6 for user	1	0	0–65535		✓	✓	✓	
	512	Parameter 7 for user	1	0	0–65535		✓	✓	✓	
	513	Parameter 8 for user	1	0	0–65535		✓	✓	✓	
	514	Parameter 9 for user	1	0	0–65535		✓	✓	✓	
515	Parameter 10 for user	1	0	0–65535	✓		✓	✓		
Position control 	419	Position command source selection	1	0	0	Conditional position control function by contact input	✓	✓	✓	6-127
					2	Conditional position pulse train command by pulse train input from the JOG terminal				
	420	Command pulse scaling factor numerator	1	1	0–32767	Set the electronic gear. Pr. 420 is a numerator and Pr. 421 is a denominator.	✓	✓	✓	
	421	Command pulse scaling factor denominator	1	1	0–32767		✓	✓	✓	
	422	Position loop gain	1 1/s	25 1/s	0–150 1/s	Set the gain of the position loop.	✓	✓	✓	
	423	Position feed forward gain	1%	0%	0–100%	Function to cancel a delay caused by the droop pulses of the deviation counter.	✓	✓	✓	
	424	Position command acceleration/deceleration time constant	0.001s	0s	0–50s	Used when rotation has become unsmooth at a large electronic gear ratio (about 10 times or more) and low speed.	✓	✓	✓	
425	Position feed forward command filter	0.001s	0s	0–5s	Enters the primary delay filter in response to the feed forward command.	✓	✓	✓		

Tab. 6-1: Parameter overview (49)

Function	Parameter	Name	Increments	Initial Value	Setting Range	Description	Parameter copy	Parameter clear	All parameter clear	Refer to page	
							✓: enabled —: disabled				
Position control Vector	426	In-position width	1 pulse	100 pulses	0–32767 pulses	The in-position signal (Y36) turns on when the droop pulses become less than the setting.	✓	✓	✓	6-127	
	427	Excessive level error	1	40	0–400	A position error excessive (E.OD) occurs when the droop pulses exceed the setting.	✓	✓	✓		
					9999	Function invalid					
	428	Command pulse selection	1	0	0–2	Pulse train + sign Sink logic	✓	✓	✓		
					3–5	Pulse train + sign Source logic					
	429	Clear signal selection	1	1	0	Deviation counter is cleared at trailing edge (at the moment when H level is changed to L level)	✓	✓	✓		
					1	Deviation counter is cleared at L level					
	430	Pulse monitor selection	1	9999	0	Description	FR-DU07/PU-04 display	✓	✓		✓
						The cumulative command pulse value is displayed.					
					1	The cumulative feedback pulse value is displayed.	Upper 4(5) digits				
							Lower 4(5) digits				
					2	The droop pulses are monitored.	Upper 4(5) digits				
Lower 4(5) digits											
3					Frequency monitor is displayed.	Upper 4(5) digits					
4	Upper 4(5) digits										
5	Lower 4(5) digits										
9999	Upper 4(5) digits										
464	Digital position control sudden stop deceleration time	0.1s	0	0–360.0s	Set the time until the inverter stops when the forward rotation (reverse rotation) command is turned off with the position feed forward function.	✓	✓	✓			
—	450	Refer to Pr. 71									
—	451	Refer to Pr. 80									
—	453 454	Refer to Pr. 80									
—	455 — 463	Refer to Pr. 82									
—	464	Refer to Pr. 419 to Pr. 430									

Tab. 6-1: Parameter overview (50)

Function	Parameter		Increments	Initial Value	Setting Range	Description		Para- meter copy	Para- meter clear	All para- meter clear	Refer to page
	Related parameters	Name						✓: enabled —: disabled			
Vector Conditional position feed function						Selection Method	Position Feed Speed				
	465	First position feed amount lower 4 digits	1	0	0-9999	RH	High speed (Pr. 4)	✓	✓	✓	6-131
	466	First position feed amount upper 4 digits	1	0	0-9999			✓	✓	✓	
	467	Second position feed amount lower 4 digits	1	0	0-9999	RM	Middle speed (Pr. 5)	✓	✓	✓	
	468	Second position feed amount upper 4 digits	1	0	0-9999			✓	✓	✓	
	469	Third position feed amount lower 4 digits	1	0	0-9999	RL	Low speed (Pr. 6)	✓	✓	✓	
	470	Third position feed amount upper 4 digits	1	0	0-9999			✓	✓	✓	
	471	Fourth position feed amount lower 4 digits	1	0	0-9999	RM, RL	Speed 4 (Pr. 24)	✓	✓	✓	
	472	Fourth position feed amount upper 4 digits	1	0	0-9999			✓	✓	✓	
	473	Fifth position feed amount lower 4 digits	1	0	0-9999	RH, RL	Speed 5 (Pr. 25)	✓	✓	✓	
	474	Fifth position feed amount upper 4 digits	1	0	0-9999			✓	✓	✓	
	475	Sixth position feed amount lower 4 digits	1	0	0-9999	RH, RM	Speed 6 (Pr. 26)	✓	✓	✓	
	476	Sixth position feed amount upper 4 digits	1	0	0-9999			✓	✓	✓	
	477	Seventh position feed amount lower 4 digits	1	0	0-9999	RH, RM, RL	Speed 7 (Pr. 27)	✓	✓	✓	
	478	Seventh position feed amount upper 4 digits	1	0	0-9999			✓	✓	✓	
	479	Eighth position feed amount lower 4 digits	1	0	0-9999	REX	Speed 8 (Pr. 232)	✓	✓	✓	
480	Eighth position feed amount upper 4 digits	1	0	0-9999	✓			✓	✓		
481	Ninth position feed amount lower 4 digits	1	0	0-9999	REX, RL	Speed 9 (Pr. 233)	✓	✓	✓		
482	Ninth position feed amount upper 4 digits	1	0	0-9999			✓	✓	✓		

Tab. 6-1: Parameter overview (51)

Function	Parameter	Name	Increments	Initial Value	Setting Range	Description		Parameter copy	Parameter clear	All parameter clear	Refer to page
								✓: enabled —: disabled			
Conditional position feed function Vector	483	Tenth position feed amount lower 4 digits	1	0	0-9999	REX, RM	Speed 10 (Pr. 234)	✓	✓	✓	6-131
	484	Tenth position feed amount upper 4 digits	1	0	0-9999						
	485	Eleventh position feed amount lower 4 digits	1	0	0-9999	REX, RM, RL	Speed 11 (Pr. 235)	✓	✓	✓	
	486	Eleventh position feed amount upper 4 digits	1	0	0-9999						
	487	Twelfth position feed amount lower 4 digits	1	0	0-9999	REX, RH	Speed 12 (Pr. 236)	✓	✓	✓	
	488	Twelfth position feed amount upper 4 digits	1	0	0-9999						
	489	Thirteenth position feed amount lower 4 digits	1	0	0-9999	REX, RH, RL	Speed 13 (Pr. 237)	✓	✓	✓	
	490	Thirteenth position feed amount upper 4 digits	1	0	0-9999						
	491	Fourteenth position feed amount lower 4 digits	1	0	0-9999	REX, RH, RM	Speed 14 (Pr. 238)	✓	✓	✓	
	492	Fourteenth position feed amount upper 4 digits	1	0	0-9999						
	493	Fifteenth position feed amount lower 4 digits	1	0	0-9999	REX, RH, RM, RL	Speed 15 (Pr. 239)	✓	✓	✓	
	494	Fifteenth position feed amount upper 4 digits	1	0	0-9999						
Remote output function (REM signal)	495	Remote output selection	1	0	0	Remote output data clear at powering off	Remote output data clear at inverter reset	✓	✓	✓	6-318
					1	Remote output data retention even at powering off					
					10	Remote output data clear at powering off	Remote output data retention at inverter reset				
					11	Remote output data retention even at powering off					
	496	Remote output data 1	1	0	0-4095	Output terminal can be switched on and off.	—				
497	Remote output data 2	1	0	0-4095	—	—	—				
—	498	Refer to Pr. 417									





Tab. 6-1: Parameter overview (51)

Function	Parameter	Name	Increments	Initial Value	Setting Range	Description	Parameter copy	Parameter clear	All parameter clear	Refer to page
							✓: enabled —: disabled			
To determine the maintenance time of parts.	503	Maintenance timer	1	0	0 (1–9998)	Display the cumulative energizing time of the inverter in 100h increments. Reading only Writing the setting of "0" clears the cumulative energizing time.	—	—	—	6-535
	504	Maintenance timer alarm output set time	1	9999	0–9998	Set the time taken until when the maintenance timer alarm output signal (Y95) is output.	✓	—	✓	
					9999	No Function				
—	505	Siehe Pr. 37								
	516 – 519	Siehe Pr. 29								
Inverter setup using USB communication	547	USB communication station number	1	0	0–31	Specify the inverter station number.	✓	✓	✓	6-490
	548	USB communication check time interval	0.1s	9999	0	USB communication is enabled. However, the inverter will come to an alarm stop (E.USB) if operation is changed to PU operation mode.	✓	✓	✓	
					0.1–999.8s	Set the interval of communication check time.				
					9999	No communication check				
551	Refer to Pr. 338 and Pr. 339									
—	549	Refer to Pr. 117								
	550 – 551	Refer to Pr. 338 and Pr. 339								
Current average monitor signal	555	Current average time	0.1s	1s	0.1–1.0s	Set the time taken to average the current during start bit output (1s).	✓	✓	✓	6-536
	556	Data output mask time	0.1s	0s	0.0–20.0s	Set the time for not obtaining (mask) transient state data.	✓	✓	✓	
	557	Current average value monitor signal output reference current	0.01/0.1A *	Rated inverter current	0–500/0–3600A *	Set the reference (100%) for outputting the signal of the current average value * <i>Setting increments and setting range differ according to the inverter capacity: (01800 or less/02160 or more)</i>	✓	✓	✓	

**Tab. 6-1:** Parameter overview (53)

Function	Parameter Related parameters	Name	Increments	Initial Value	Setting Range	Description	Parameter copy	Parameter clear	All parameter clear	Refer to page
							✓: enabled —: disabled			
—	563 564	Refer to Pr. 52								
	569	Refer to Pr. 80								
Multiple rating	570	Multiple rating setting	1	2	0 *	SLD Ambient temperature 40°C, Overload current rating 110% 60s, 120% 3s (Inverse time characteristics) * This function is valid for V/f control only. This parameter can be set only when "9999" is set in Pr. 80, Pr. 81, Pr. 453, and Pr. 454.	✓	—	—	6-166
					1 *	LD Ambient temperature 50°C, Overload current rating 120% 60s, 150% 3s (Inverse time characteristics) * This function is valid for V/f control only. This parameter can be set only when "9999" is set in Pr. 80, Pr. 81, Pr. 453, and Pr. 454.				
					2	ND Ambient temperature 50°C, Overload current rating 150% 60s, 200% 3s (Inverse time characteristics)				
					3	HD Ambient temperature 50°C, Overload current rating 200% 60s, 250% 3s (Inverse time characteristics)				
—	571	Refer to Pr. 13								
	573	Refer to Pr. 73								
	574	Refer to Pr. 95								
	575 – 577	Refer to Pr. 127								
Traverse function	592	Traverse function selection	1	0	0	Traverse function invalid	✓	✓	✓	6-524
					1	Traverse function is valid only in the external operation mode				
					2	Traverse function is valid independently of operation mode				
	593	Maximum amplitude amount	0.1%	10%	0–25%	Amplitude amount during traverse operation	✓	✓	✓	
	594	Amplitude compensation amount during deceleration	0.1%	10%	0–50%	Compensation amount at the time of amplitude inversion (acceleration → deceleration)	✓	✓	✓	
	595	Amplitude compensation amount during acceleration	0.1%	10%	0–50%	Compensation amount during amplitude inversion operation (deceleration → acceleration)	✓	✓	✓	
596	Amplitude acceleration time	0.1s	5s	0.1–3600s	Acceleration time during traverse operation	✓	✓	✓		
597	Amplitude deceleration time	0.1s	5s	0.1–3600s	Deceleration time during traverse operation	✓	✓	✓		

Tab. 6-1: Parameter overview (54)

Function	Parameter	Name	Increments	Initial Value	Setting Range	Description	Parameter copy	Parameter clear	All parameter clear	Refer to page
							✓: enabled —: disabled			
—	611	Refer to Pr. 57								
	665	Refer to Pr. 882								
	684	Refer to Pr. 82								
	800	Refer to Pr. 81								
	802	Refer to Pr. 10								
	803	Refer to Pr. 22								
Torque command source selection  	804	Torque command source selection	1	0	0	Torque command by terminal 1 analog input	✓	✓	✓	6-113
					1	Torque command by parameter Pr. 805 or Pr. 806 setting (–400 % to +400 %)				
					3	Torque command by using CC-Link (FRA7NC)				
					4	Digital input from the option (FR-A7AX)				
					5	Torque command by using CC-Link (FR-A7NC)				
	6	Torque command by using CC-Link (FR-A7NC)								
805	Torque command value (RAM)	1%	1000%	600 – 1400%	Digital setting of the torque command can be made by setting Pr. 805 or Pr. 806. (Setting from communication option, etc. can be made.) In this case, set the speed limit value to an appropriate value to prevent overspeed.	—	✓	✓		
806	Torque command value (RAM, EEPROM)					✓	✓	✓		
Speed limit  	807	Speed limit selection	1	0	0	Use the speed command value during speed control as speed limit.	✓	✓	✓	6-117
					1	According to Pr. 808 and Pr. 809, set the speed limit in forward and reverse rotation directions individually.				
					2	The analog voltage of the terminal 1 input is used to make speed limit. For 0 to 10V input, set the forward rotation speed limit. (The reverse rotation speed limit is Pr. 1 Maximum frequency.) For –10 to 0V input, set the reverse rotation speed limit. (The forward rotation speed limit is Pr. 1 "Maximum frequency".) The maximum frequency of both the forward and reverse rotations is Pr. 1 "Maximum frequency".				
	808	Forward rotation speed limit	0.01Hz	50Hz	0–120Hz	Set the speed limit level during forward rotation. (valid when Pr. 807 = 1)	✓	✓	✓	
	809	Reverse rotation speed limit	0.01Hz	9999	0–120Hz	Set the speed limit level during reverse rotation. (valid when Pr. 807 = 1)	✓	✓	✓	
9999					The setting is the same as that of the torque limit in the forward rotation direction.					

Tab. 6-1: Parameter overview (55)

Function	Parameter	Name	Increments	Initial Value	Setting Range	Description	Para- meter copy	Para- meter clear	All para- meter clear	Refer to page
							✓: enabled —: disabled			
—	810	Refer to Pr. 22								
	811	Refer to Pr. 22 and Pr. 37								
	812 — 817	Refer to Pr. 22								
Easy gain tuning selection Vector Sensorless	818	Easy gain tuning response level setting	1	2	1–15	1: Slow response ↓ 15: Fast response	✓	✓	✓	6-88
	819	Easy gain tuning selection	1	0	0	No tuning	✓	—	✓	
					1	With load estimation (only under vector control)				
2	The optimum gain is automatically set from the torque command and speed during motor operation. Manual input of load (Pr. 880)									
Speed loop proportional gain setting Vector Sensorless	820	Speed control P gain 1	1%	60%	0–1000%	Set the proportional gain for speed control. (Increasing the value improves trackability in response to a speed command change and reduces speed variation with disturbance.)	✓	✓	✓	6-88
	830	Speed control P gain 2	1%	9999	0–1000%	Second function of Pr. 820 (valid when RT signal is on)	✓	✓	✓	
					9999	No function				
Speed control integral time setting Vector Sensorless	821	Speed control integral time 1	0.001s	0.333s	0–20s	Set the integral time during speed control. (Decrease the value to shorten the time taken for returning to the original speed if speed variation with disturbance occurs.)	✓	✓	✓	6-88
	831	Speed control integral time 2	0.001s	9999	0–20s	Second function of Pr. 821 (valid when the RT terminal is on)	✓	✓	✓	
					9999	No function				
—	822	Siehe Pr. 74								
Speed detection filter function Vector	823	Speed detection filter 1	0.001s	0.001s	0–0.1s	Set the primary delay filter for the speed feedback.	✓	✓	✓	6-144
	833	Speed detection filter 2	0.001s	9999	0–0.1s	Second function of Pr. 823 (valid when RT signal is on)	✓	✓	✓	
					9999	No function				

Tab. 6-1: Parameter overview (56)



Function	Parameter <small>Related parameters</small>	Name	Increments	Initial Value	Setting Range	Description	Parameter copy	Parameter clear	All parameter clear	Refer to page
							✓: enabled —: disabled			
Current loop proportional gain setting <small>(Sensorless)</small> <small>Vector</small>	824	Torque control P gain 1	1%	100%	0–200%	Set the proportional gain for the current control of the q and d axes. (Increasing the value improves trackability in response to a current command change and reduces current variation with disturbance.)	✓	✓	✓	6-124
		834	Torque control P gain 2	1%	9999	0–200%	Second function of Pr. 824 (valid when the RT terminal is on)	✓	✓	
						9999	No function	✓	✓	
Current control integral time setting <small>(Sensorless)</small> <small>Vector</small>	825	Torque control integral time 1	0.1ms	5ms	0–500ms	Set the integral time for the current control of the q and d axes. (Decreasing the value shortens the time taken to return to the original torque if current variation with disturbance occurs.)	✓	✓	✓	6-124
		835	Torque control integral time 2	0.1ms	9999	0–500ms	Second function of Pr. 825 (valid when the RT signal is on)	✓	✓	
						9999	No function	✓	✓	
—	826	Refer to Pr. 74								
Torque detection filter function <small>(Sensorless)</small> <small>Vector</small>	827	Torque detection filter 1	0.001s	0 s	0–0.1s	Set the primary delay filter for the current feedback.	✓	✓	✓	6-144
		837	Torque detection filter 2	0.001s	9999	0–0.1s	Second function of Pr. 827 (valid when the RT signal is on)	✓	✓	
						9999	No function	✓	✓	





Tab. 6-1: Parameter overview (57)

Function	Parameter	Name	Increments	Initial Value	Setting Range	Description	Para- meter copy	Para- meter clear	All para- meter clear	Refer to page
							✓: enabled —: disabled			
Speed feed forward control, model adaptive speed control  <div style="display: flex; justify-content: space-between; align-items: center;"> <div style="border: 1px solid black; padding: 2px; font-size: 8px;">Sensorless</div> <div style="border: 1px solid black; padding: 2px; font-size: 8px;">Vector</div> </div>	828	Model speed control gain	1%	60%	0-1000%	Set the gain for model speed controller.	✓	✓	✓	6-99
	877	Speed feed forward control/model adaptive speed control selection	1	0	0	Normal speed control is exercised				
					1	Speed feed forward control is exercised.	✓	✓	✓	
					2	Model adaptive speed control is enabled.				
	878	Speed feed forward filter	0.01s	0s	0-1s	Set the primary delay filter for the speed feed forward result calculated using the speed command and load inertia ratio.	✓	✓	✓	
	879	Speed feed forward torque limit	0.1%	150%	0-400%	Limits the maximum value of the speed feed forward torque.	✓	✓	✓	
	880	Load inertia ratio	0.1	7	0-200	Set the load inertia ratio. Inertia ratio found by easy gain turning.	✓	—	✓	
881	Speed feed forward gain	1%	0%	0-1000%	Set the feed forward calculation result as a gain.	✓	✓	✓		
—	830	Refer to Pr. 820								
	831	Refer to Pr. 821								
	832	Refer to Pr. 74								
	833	Refer to Pr. 823								
	834	Refer to Pr. 824								
	835	Refer to Pr. 825								
	836	Refer to Pr. 74								
	837	Refer to Pr. 827								

**Tab. 6-1:** Parameter overview (58)

Function	Parameter Related parameters	Name	Increments	Initial Value	Setting Range	Description	Parameter copy	Parameter clear	All parameter clear	Refer to page
							✓: enabled —: disabled			
Torque bias function Vector	840	Torque bias selection	1	9999	0	Set the contact signal (X42, X43) based-torque bias amount using Pr. 841 to Pr. 843.	✓	✓	✓	6-102
					1	Set the terminal 1-based torque bias amount as desired in C16 to C19. (forward rotation)				
					2	Set the terminal 1-based torque bias amount as desired in C16 to C19. (reverse rotation)				
					3	The terminal 1-based torque bias amount can be set automatically in C16 to C19, Pr. 846 according to the load.				
					9999	Without torque bias, rated torque 100%				
	841	Torque bias 1	1%	9999	600 — 999%	Negative torque bias amount (–400% to –1%)	✓	✓	✓	
	842	Torque bias 2			1000 — 1400%	Positive torque bias amount (0% to 400%)				
	843	Torque bias 3			9999	Without torque bias setting				
	844	Torque bias filter	0.001s	9999	0–5s	Time until torque rises.	✓	✓	✓	
					9999	Same operation as when 0s is set.				
	845	Torque bias operation time	0.01s	9999	0–5s	Time for maintaining torque equivalent to the torque bias amount.	✓	✓	✓	
					9999	Same operation as when 0s is set.				
	846	Torque bias balance compensation	0.1V	9999	0–10V	Set the voltage under balanced load.	✓	✓	✓	
9999					Same operation as when 0V is set.					
847	Fall-time torque bias terminal 1 bias	1%	9999	0–400%	Set the bias value of the torque command.	✓	✓	✓		
				9999	Same as at a rise time (C16, C17).					
848	Fall-time torque bias terminal 1 gain	1%	9999	0–400%	Set the gain value of the torque command.	✓	✓	✓		
				9999	Same as at a rise time (C18, C19).					
—	849	Refer to Pr. 74								
	850	Refer to Pr. 10								
	853	Refer to Pr. 285								
Excitation ratio Sensorless Vector	854	Excitation ratio	1%	100%	0–100%	Set the excitation ratio under no load.	✓	✓	✓	6-146

Tab. 6-1: Parameter overview (59)

Function	Parameter	Name	Increments	Initial Value	Setting Range	Description	Parameter copy	Parameter clear	All parameter clear	Refer to page		
							✓: enabled —: disabled					
Function assignment of analog input terminal	858	Terminal 4 function assignment	1	0	0	Frequency/speed command	✓	—	✓	6-372		
					1	Magnetic flux command						
					4	Stall prevention/torque limit						
					9999	No function						
	868	Terminal 1 function assignment	1	0	0	Frequency setting auxiliary	✓	—	✓			
					1	Magnetic flux command						
					2	Regenerative torque limit						
					3	Torque command						
					4	Stall prevention/torque limit/torque command						
					5	Forward/reverse rotation speed limit						
					6	Torque bias						
					9999	No function						
	—	859 860	Refer to Pr. 82									
	Notch filter  	862	Notch filter time constant	1	0	0-60	You can use the machine resonance speed to make this setting to reduce the response level of the machine resonance frequency band, avoiding machine resonance.	✓	✓		✓	6-109
863						Notch filter depth	1			0		
		1	14dB									
		2	8dB									
Torque detection  	864	Torque detection	0.1%	150%	0-400%	You can make setting to output a signal if the motor torque exceeds the predetermined value.	✓	✓	✓	6-317		
					3	4dB						
—	865	Refer to Pr. 41										
	866	Refer to Pr. 55										
	869	Refer to Pr. 55										
	872	Refer to Pr. 251										
Speed limit during speed control 	873	Speed limit	0.01Hz	20Hz	0-120Hz	Frequency is limited at the set frequency + Pr. 873 during vector control.	✓	✓	✓	6-107		

Tab. 6-1: Parameter overview (60)

Function	Parameter	Name	Increments	Initial Value	Setting Range	Description	Parameter copy	Parameter clear	All parameter clear	Refer to page
							✓: enabled —: disabled			
—	874	Refer to Pr. 22								
Fault definition	875	Fault definition	1	0	0	At occurrence of any alarm, the base circuit is shut off immediately. At this time, the alarm output also turns on.	✓	✓	✓	6-361
					1	At occurrence of external thermal operation (OHT), electronic thermal relay function (THM) or PTC thermistor operation (PTC) alarm, the motor is decelerated to a stop and the base circuit is shut off. At occurrence of an alarm other than OHT, THM and PTC, the base circuit is shut off immediately. Same operation as when "0" is set is performed under position control.				
—	877 – 881	Refer to Pr. 828								
Regeneration avoidance function	882	Regeneration avoidance operation selection	1	0	0	Regeneration avoidance function invalid	✓	✓	✓	6-527
					1	Regeneration avoidance function is always valid				
					2	Regeneration avoidance function is valid only at constant speed				
	883	Regeneration avoidance operation level	0.1V	760V	300–800V	Set the bus voltage level at which regeneration avoidance operates. When the bus voltage level is set to low, overvoltage error will be less apt to occur. However, the actual deceleration time increases. The set value must be higher than the power supply voltage $\times \sqrt{2}$ .	✓	✓	✓	
	884	Regeneration avoidance at deceleration detection sensitivity	1	0	0	Regeneration avoidance by bus voltage change ratio is invalid	✓	✓	✓	
					1–5	Set sensitivity to detect the bus voltage change. 1 (low) → 5 (high)				
	885	Regeneration avoidance compensation frequency limit value	0.01Hz	6Hz	0–10Hz	Set the limit value of frequency which rises at activation of regeneration avoidance function.	✓	✓	✓	
9999					Frequency limit invalid					
886	Regeneration avoidance voltage gain	0.1%	100%	0–200%	Adjust responsiveness at activation of regeneration avoidance. Setting a larger value in Pr. 886 will improve responsiveness to the bus voltage change. However, the output frequency could become unstable. When the load inertia of the motor is large, decrease the Pr. 886 setting. When vibration is not suppressed by decreasing the Pr. 886 setting, set a smaller value in Pr. 665.	✓	✓	✓		
665	Regeneration avoidance frequency gain	0.1%	100%	0–200%						

**Tab. 6-1:** Parameter overview (61)

Function	Parameter Related parameters	Name	Incre-ments	Initial Value	Setting Range	Description	Para-meter copy	Para-meter clear	All para-meter clear	Refer to page
							✓: enabled —: disabled			
Free parameter	888	Free parameter 1	1	9999	0–9999	Parameters you can use for your own purposes Used for maintenance, management, etc. by setting a unique number to each inverter when multiple inverters are used.	✓	—	—	6-540
	889	Free parameter 2	1	9999	0–9999		✓	—	—	
Energy saving monitor	891	Refer to Pr. 52								
	892	Load factor	0.1%	100%	30–150%	Set the load factor for commercial power-supply operation. This value is used to calculate the power consumption estimated value during commercial power supply operation.	✓	✓	✓	6-363
	893	Energy saving monitor reference (motor capacity)	0.01/0.1kW *	SLD/LD/ND/HD value of Applied motor Capacity	0.1–55/0–3600kW *	Set the motor capacity (pump capacity). Set when calculating power savings rate and average power savings rate value. * The setting depends on the inverter capacity: (01800 or less/02160 or more)	✓	✓	✓	
	894	Control selection during commercial power-supply operation	1	0	0	Discharge damper control (fan)	✓	✓	✓	
					1	Inlet damper control (fan)				
					2	Valve control (pump)				
					3	Commercial power-supply drive (fixed value)				
	895	Power saving rate reference value	1	9999	0	Consider the value during commercial power-supply operation as 100%.	✓	✓	✓	
					1	Consider the Pr. 893 setting as 100%.				
					9999	No function				
	896	Power unit cost	0.01	9999	0–500	Set the power unit cost. Display the power savings rate on the energy saving monitor	✓	✓	✓	
					9999	No function				
	897	Power saving monitor average time	1	9999	0	Average for 30 minutes	✓	✓	✓	
					1–1000h	Average for the set time				
					9999	No function				
	898	Power saving cumulative monitor clear	1	9999	0	Cumulative monitor value clear	✓	✓	✓	
1					Cumulative monitor value hold					
10					Cumulative monitor continue (communication data upper limit 9999)					
9999					Cumulative monitor continue (communication data upper limit 65535)					
899	Operation time rate (estimated value)	0.1%	9999	0–100%	Use for calculation of annual power saving amount. Set the annual operation ratio (consider 365 days × 24hr as 100%).	✓	✓	✓		
				9999	No function					

Tab. 6-1: Parameter overview (62)

Function	Parameter Related parameters	Name	Increments	Initial Value	Setting Range	Description	Parameter copy	Parameter clear	All parameter clear	Refer to page
							✓: enabled —: disabled			
Adjustment of terminal CA and AM (calibration)	C0 (900)	CA terminal calibration	—	—	—	Calibrate the scale of the meter connected to terminal CA.	✓	—	✓	6-336
	C1 (901)	AM terminal calibration	—	—	—	Calibrate the scale of the analog meter connected to terminal AM.	✓	—	✓	
—	C2 (902) – C7 (905)	Refer to Pr. 125 and Pr. 126								
Analog output current calibration	C8 (930)	Current output bias signal	0.1%	0%	0–100%	Set the output signal value at the minimum analog current output.	✓	✓	✓	6-336
	C9 (930)	Current output bias current	0.1%	0%	0–100%	Set the minimum current value at the minimum analog current output.	✓	✓	✓	
	C10 (931)	Current output gain signal	0.1%	100%	0–100%	Set the output signal value at the maximum analog current output.	✓	✓	✓	
	C11 (931)	Current output gain current	0.1%	100%	0–100%	Set the maximum current value at the maximum analog current output.	✓	✓	✓	
Adjustment of analog input torque magnetic flux command (calibration)	C12 (917)	Terminal 1 bias frequency (speed)	0.01Hz	0Hz	0–400Hz	Set the frequency on the bias side of terminal 1 input. (valid when Pr. 868 = 5)	✓	—	✓	6-385
	C13 (917)	Terminal 1 bias (speed)	0.1%	0%	0–300%	Set the converted % of the bias side voltage (current) of terminal 1 input. (valid when Pr. 868 = 5)	✓	—	✓	
	C14 (918)	Terminal 1 gain frequency (speed)	0.01Hz	50Hz	0–400Hz	Set the frequency of terminal 1 input gain (maximum). (valid when Pr. 868 = 5)	✓	—	✓	
	C15 (918)	Terminal 1 gain (speed)	0.1%	100%	0–300%	Set the converted % of the gain side voltage (current) of terminal 1 input. (valid when Pr. 868 = 5)	✓	—	✓	
	C16 (919)	Terminal 1 bias command (torque/magnetic flux)	0.1%	0%	0–400%	Set the torque/magnetic flux command value on the bias side of terminal 1 input. (valid when Pr. 868 ≠ 0, 5)	✓	—	✓	
	C17 (919)	Terminal 1 bias (torque/magnetic flux)	0.1%	0%	0–300%	Set the converted % of the bias side voltage (current) of terminal 1 input. (valid when Pr. 868 ≠ 0, 5)	✓	—	✓	
	C18 (920)	Terminal 1 gain command (torque/magnetic flux)	0.1%	150%	0–400%	Set the torque/magnetic flux command value on the gain side of terminal 1 input. (valid when Pr. 868 ≠ 0, 5)	✓	—	✓	
	C19 (920)	Terminal 1 gain (torque/magnetic flux)	0.1%	100%	0–300%	Set the converted % of the gain side voltage (current) of terminal 1 input. (valid when Pr. 868 ≠ 0, 5)	✓	—	✓	

**Tab. 6-1:** Parameter overview (63)

Function	Parameter Related parameters	Name	Increments	Initial Value	Setting Range	Description	Parameter copy	Parameter clear	All parameter clear	Refer to page	
							✓: enabled —: disabled				
Adjustment of analog input torque magnetic flux command (calibration)	C38 (932)	Terminal 4 bias command (torque/magnetic flux)	0.1%	0%	0–400%	Set the torque/magnetic flux command value on the bias side of terminal 4 input. (valid when Pr. 858 = 1, 4)	✓	—	✓	6-394	
	C39 (932)	Terminal 4 bias (torque/magnetic flux)	0.1%	20%	0–300%	Set the converted % of the bias side current (voltage) of terminal 4 input. (valid when Pr. 858 = 1, 4)	✓	—	✓		
	C40 (933)	Terminal 4 gain command (torque/magnetic flux)	0.1%	150%	0–400%	Set the torque/magnetic flux command value on the bias side of terminal 4 input. (valid when Pr. 858 = 1, 4)	✓	—	✓		
	C41 (933)	Terminal 4 gain (torque/magnetic flux)	0.1%	100%	0–300%	Set the converted % of the gain side current (voltage) of terminal 4 input. (valid when Pr. 858 = 1, 4)	✓	—	✓		
—	989	Parameter copy alarm release	1	10/100 *	10/100	Parameters for alarm release at parameter copy * The setting depends on the inverter capacity: (01800 or less/02160 or more)	✓	—	✓	—	
Buzzer control of the operation panel	990	PU buzzer control	1	1	0	Without buzzer	✓	✓	✓	6-542	
					1	With buzzer					
PU contrast adjustment	991	PU contrast adjustment	1	58	0–63	Contrast adjustment of the LCD of the parameter unit (FR-PU04/FR-PU07) can be performed. 0 (light) → 63 (dark)	✓	—	✓	6-542	
Parameter clear, parameter copy	Pr.CL	Parameter clear	1	0	0/1	Setting "1" returns all parameters except calibration parameters to the initial values.				4-11	
	ALLC	All parameter clear	1	0	0/1	Setting "1" returns all parameters to the initial values.				4-12	
	Er.CL	Alarm history clear	1	0	0/1	Setting "1" will clear eight past alarms.				7-27	
	PCPY	Parameter copy	1	0	0	0	Cancel				4-13
				0	1	0	1	Read the source parameters to the operation panel.			
0				2	0	2	Write the parameters copied to the operation panel to the destination inverter.				
0				3	0	3	Verify parameters in the inverter and operation panel.				

Tab. 6-1: Parameter overview (64)

**NOTE**

The parameter number in parentheses is the one for use with the parameter unit (FR-PU04/FR-PU07).



## 6.2 Control mode

V/f control (initial setting), advanced magnetic flux vector control, real sensorless vector control and vector control are available with this inverter.

### V/f control

It controls frequency and voltage so that the ratio of frequency (f) to voltage (V) is constant when changing frequency.

### Advanced magnetic flux vector control

This control divides the inverter output current into an excitation current and a torque current by vector calculation and makes voltage compensation to flow a motor current which meets the load torque.

### Real sensorless vector control

By estimating the motor speed, speed control and torque control with more advanced current control function are enabled. When high accuracy and fast response is necessary, select the real sensorless vector control and perform offline auto tuning and online auto tuning. This control can be applied to the following applications:

- To minimize the speed fluctuation even at a severe load fluctuation
- To generate low speed torque
- To prevent machine from damage due to too large torque (torque limit)
- To perform torque control

### Vector control

When the FR-A7AP is mounted, full-scale vector control operation can be performed using a motor with encoder. Fast response/high accuracy speed control (zero speed control, servo lock), torque control, and position control can be performed.

#### ● What is vector control?

Excellent control characteristics when compared to V/f control and other control techniques, achieving the control characteristics equal to those of DC machines. It is suitable for applications below.

- To minimize the speed fluctuation even at a severe load fluctuation
- To generate low speed torque
- To prevent machine from damage due to too large torque (torque limit)
- To perform torque control or position control
- Servo-lock torque control which generates a torque at zero speed (i.e. status of motor shaft = stopped)

### 6.2.1 What is vector control?

Vector control is one of the control techniques for driving an induction motor. To help explain vector control, the fundamental equivalent circuit of an induction motor is shown below:

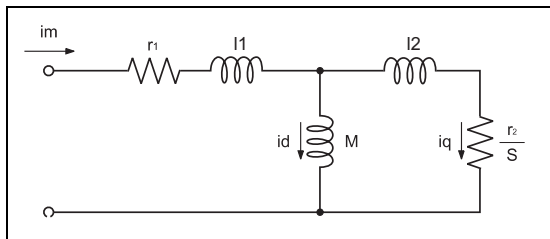

**Fig. 6-1:**  
Equivalent circuit of an induction motor

I001497E

- r1: Primary resistance
- r2: Secondary resistance
- l1: Primary leakage inductance
- l2: Secondary leakage inductance
- M: Mutual inductance
- S: Slip
- id: Excitation current
- iq: Torque current
- im: Motor current

In the above diagram, currents flowing in the induction motor can be classified into a current  $i_d$  (excitation current) for making a magnetic flux in the motor and a current  $i_q$  (torque current) for causing the motor to develop a torque.

- In vector control, the voltage and output frequency are calculated to control the motor so that the excitation current and torque current (as shown in the left figure) flow to the optimum as described below:

The excitation current is controlled to place the internal magnetic flux of the motor in the optimum status. Derive the torque command value so that the difference between the motor speed command and the actual speed (speed estimated value for real sensorless vector control) obtained from the encoder connected to the motor shaft is zero. Torque current is controlled so that torque as set in the torque command is developed.

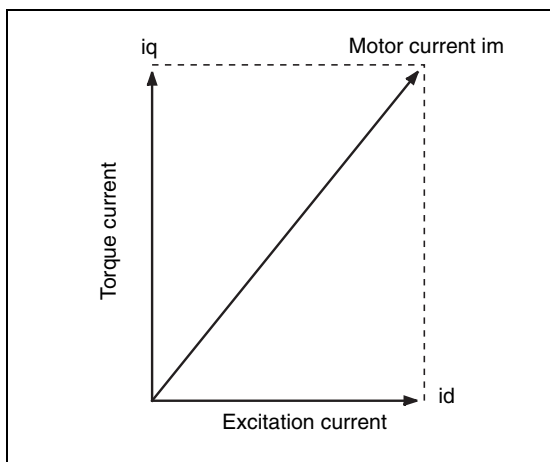

**Fig. 6-2:**  
Motor current components

I001498E

Motor-generated torque ( $T_M$ ), slip angular velocity ( $\omega_s$ ) and the motor's secondary magnetic flux ( $\phi_2$ ) can be found by the following calculation::

$$T_M \sim \phi_2 \times i_q$$

$$\phi_2 = M \times i_d$$

$$\omega_s = \frac{r_2}{L_2} \times \frac{i_q}{i_d}$$

where,  $L_2$  = secondary inductance

$$L_2 = l_2 + M$$

Vector control provides the following advantages:

- Excellent control characteristics when compared to V/f control and other control techniques, achieving the control characteristics equal to those of DC machines.
- Applicable to high-response applications with which induction motors were previously regarded as difficult to use. Applications requiring a wide variable-speed range from extremely low speed to high speed, frequent acceleration/deceleration operations, continuous four-quadrant operations etc.
- Allows torque control.
- Allows servo-lock torque control which generates a torque at zero speed (i.e. status of motor shaft = stopped). (Cannot be performed under real sensorless vector control.)

**Block diagram of real sensorless vector control**

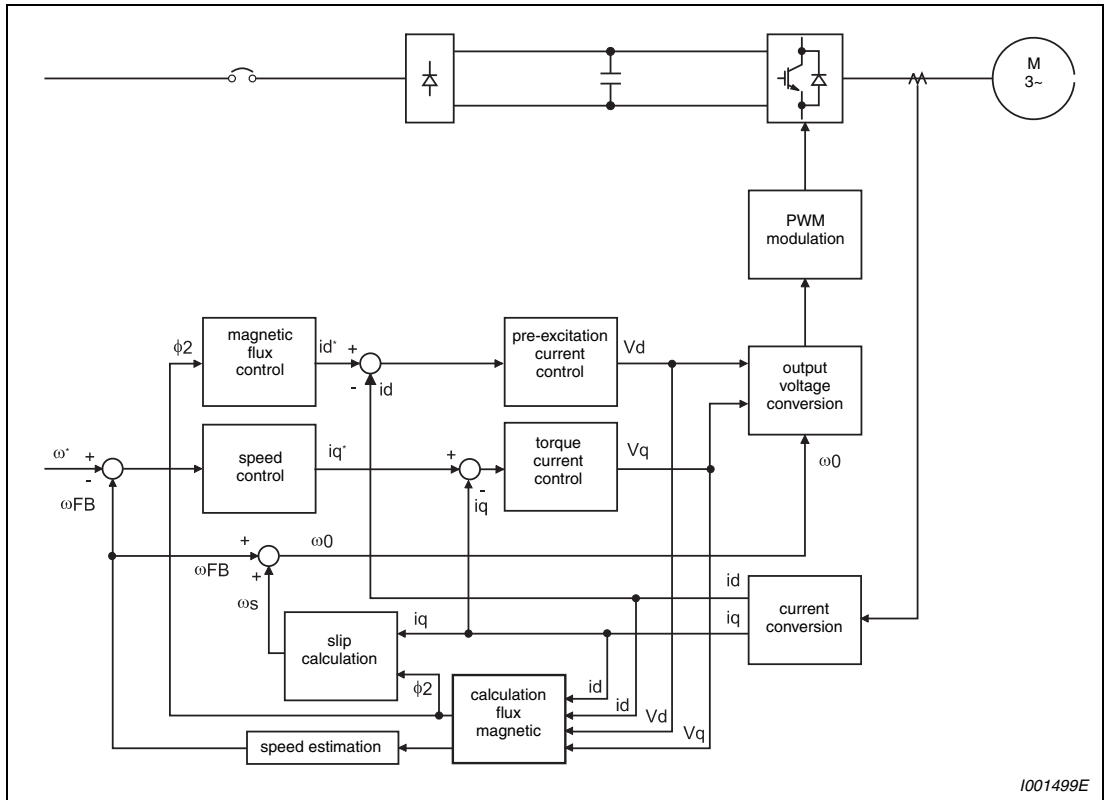

**Fig. 6-3:** Block diagram of real sensorless vector control

**Block diagram of vector control**

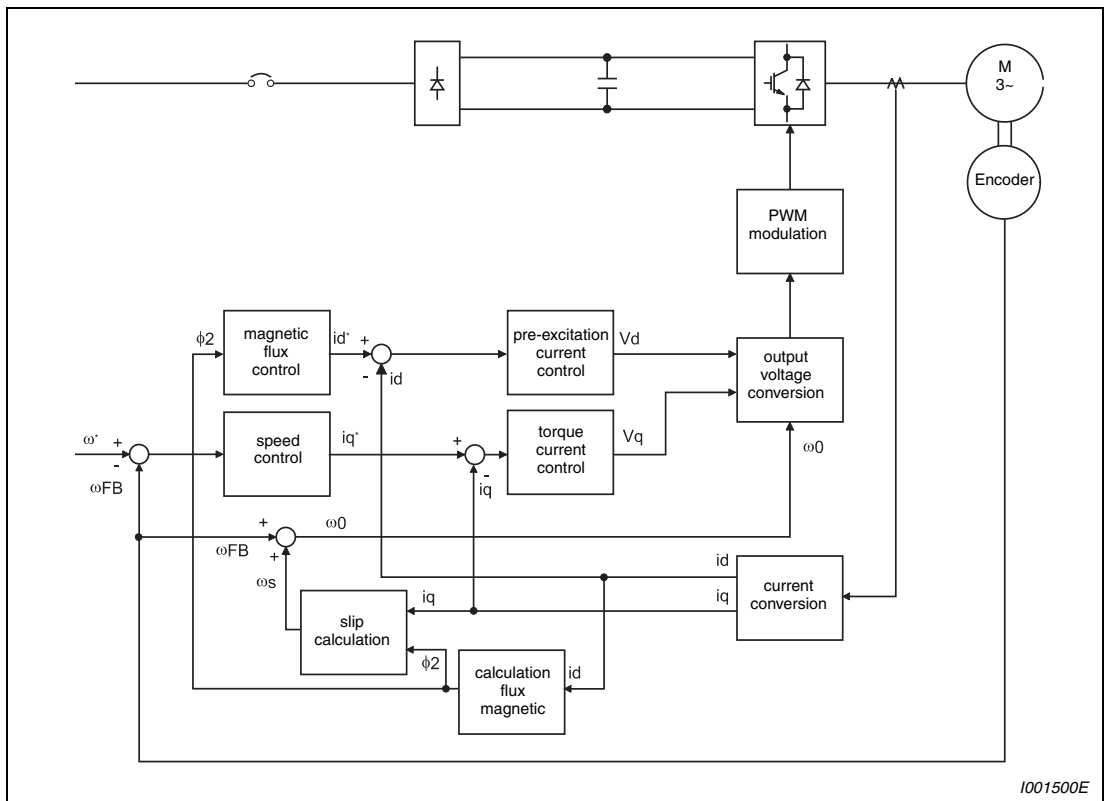

**Fig. 6-4:** Block diagram of vector control

- Speed control  
Speed control operation is performed to zero the difference between the speed command ( $\omega^*$ ) and actual rotation detection value ( $\omega_{FB}$ ). At this time, the motor load is found and its result is transferred to the torque current controller as a torque current command ( $i_q^*$ ).
- Torque current control  
A voltage ( $V_q$ ) is calculated to start a current ( $i_q^*$ ) which is identical to the torque current command ( $i_q$ ) found by the speed controller.
- Magnetic flux control  
The magnetic flux ( $\phi_2$ ) of the motor is derived from the excitation current ( $i_d$ ). The excitation current command ( $i_d^*$ ) is calculated to use that motor magnetic flux ( $\phi_2$ ) as a predetermined magnetic flux.
- Excitation current control  
A voltage ( $V_d$ ) is calculated to start a current ( $i_d$ ) which is identical to the excitation current command ( $i_d^*$ ) found by magnetic flux control.
- Output frequency calculation  
Motor slip ( $\omega_s$ ) is calculated on the basis of the torque current value ( $i_q$ ) and magnetic flux ( $\phi_2$ ). The output frequency is found by adding that slip ( $\omega_s$ ) to the feedback ( $\omega_{FB}$ ) found by a feedback from the encoder.

The above results are used to make PWM modulation and run the motor.

## 6.2.2 Change the control method (Pr. 80, Pr. 81, Pr. 451, Pr. 800)

Set when selecting the advanced magnetic flux vector control, real sensorless vector control or vector control. Select a control mode from speed control mode, torque control mode and position control mode under real sensorless vector control or vector control. The initial value is V/f control.

- Select a control method using Pr. 800 (Pr. 451) "Control method selection".
- Each control method can be switched using a method switching signal (MC).

Pr. No.	Name	Initial Value	Setting Range	Description	Parameters referred to	Refer to Section		
80	Motor capacity	9999	01800 or less	0.4–55kW	Set the applied motor capacity.	Advanced magnetic flux vector control	6.7.2	
			02160 or more	0–3600kW				Real sensorless vector control, vector control (speed control)
			9999		V/f control			
81	Number of motor poles	9999	2/4/6/8/10		Set the number of motor poles.	Real sensorless vector control, vector control (torque control)	6.4	
			12/14/16/18/20	X18 signal-ON: V/f control	Set 10 + number of motor poles			
			9999		V/f control			
800	Control method selection	20	0–5		Vector control	178–189	Input terminal function selection	6.14.1
			9		Vector control test operation			
			10/11/12		Real sensorless vector control	450	Second applied motor	6.12.2
			20		V/f control (advanced magnetic flux vector control)	804	Torque command source selection	6.4.4
451	Second motor control method selection	9999	10/11/12		Real sensorless vector control	807	Speed limit selection	6.4.5
			20		V/f control (advanced magnetic flux vector control)	810	Torque limit input method selection	6.3.2
			9999		Second motor is invalid	858	Terminal 4 function assignment	6.20.1
					868	Terminal 1 function assignment	6.20.1	

### Setting of the motor capacity and the number of motor poles (Pr. 80, Pr. 81 )

- Motor specifications(the motor capacity and the number of motor poles) must be set to select advanced magnetic flux vector control, real sensorless vector control or vector control.
- Set the motor capacity (kW) in Pr. 80 "Motor capacity" and set the number of motor poles in Pr. 81 "Number of motor poles".

### Selection of control method and control mode

Select the inverter control method for V/f control, advanced magnetic flux vector control (speed control), real sensorless vector control (speed control, torque control) and vector control (speed control, torque control, and position control).

Pr. 80, Pr. 81	Pr. 800	Pr. 451	Control Method	Control Mode	Remarks
≠ 9999	0	—	Vector control	Speed control	—
	1	—		Torque control	—
	2	—		Speed control-torque control switchover	MC ON: Torque control MC OFF: Speed control
	3	—		Position control	—
	4	—		Speed control-position control switchover	MC ON: Position control MC OFF: Speed control
	5	—		Position control-torque control switchover	MC ON: Torque control MC OFF: Position control
	9	—	Vector control test operation		
	10		Real sensorless vector control	Speed control	—
	11			Torque control	—
	12			Speed control-torque control switchover	MC ON: Torque control MC OFF: Speed control
	20 Pr. 800 initial value)		Advanced magnetic flux vector control	Speed control	—
	—	9999 (Pr. 451 initial value)	V/f control, advanced magnetic flux vector control		
	9999	— <sup>①</sup>	V/f control		

**Tab. 6-2:** Selection of control method

① Control method is V/f control regardless of the setting value of Pr. 800 when "9999" is set in Pr. 80 "Motor capacity" or Pr. 81 "Number of motor poles".

#### Vector control test operation (Pr. 800 = 9)

Speed control test operation can be performed even when the motor is not connected. The speed calculation value changes to track the speed command and the transition can be checked with the operation panel and analog signal output at CA and AM.

#### NOTES

Since current is not detected and voltage is not output, monitors related to current and voltage such as output current and output voltage, etc. and output signals do not function.

For speed calculation, speed is calculated in consideration of Pr. 880 "Load inertia ratio".

**Control method switching by external terminals (RT signal, X18 signal)**

- The switching of the control method (V/f control, advanced magnetic flux vector control, real sensorless vector control and vector control) by the external terminal may be made in either of the following two ways: switching by the second function selection signal (RT), or V/f switching signal (X18).
- Two types of control method can be switched with the RT signal by setting the type of motor to be used as second motor in Pr. 450 "Second applied motor" and control method of the motor in Pr. 451 "Second motor control method selection". Turn on the RT signal to select the second function.
- For switching by the X18 signal, setting "12, 14, 16, 18, 20" in Pr. 81 "Number of motor poles" and turning the X18 signal on switches the currently selected control method (advanced magnetic flux vector control, real sensorless vector control and vector control) to V/f control. In this case, electronic thermal relay characteristic, etc. can not be changed. Therefore, use this terminal only for changing the control system of one motor. For the terminal used for X18 signal input, set "18" in any of Pr. 178 to Pr. 189 "Input terminal function selection" to assign the function.

First Motor Control Method	Second Motor Control Method (RT signal is on)	Pr. 450	Pr. 453, Pr. 454	Pr. 451
V/f control	V/f control	9999	—	—
	Advanced magnetic flux vector control	≠ 9999	9999	—
	Real sensorless vector control		≠ 9999	20, 9999 10–12
Advanced magnetic flux vector control, Real sensorless vector control	Same control as the first motor ①	9999	—	—
	V/f control	≠ 9999	9999	—
	Advanced magnetic flux vector control		≠ 9999	20, 9999
	Real sensorless vector control			10–12

**Tab. 6-3:** Control of the first and second motor

- ① V/f control is selected when "12, 14, 16, 18, 20" is set in Pr. 81 and the X18 signal is on. When the X18 signal is not assigned, turning the RT signal on selects V/f control as the RT signal shares this function.

**NOTES**

The RT signal is assigned to the terminal RT in the initial setting. By setting "3" in any of Pr. 178 to Pr. 189 "Input terminal function selection", you can assign the RT signal to the other terminal.

The RT signal acts as the second function selection signal and makes the other second functions valid. (Refer to section 6.14.3.)



### Switching the control method from the external terminal (MC signal)

- When "12 (2)" is set in Pr. 800 (Pr. 451 ), speed control is selected when the control mode switching signal (MC) is off, and torque control is selected when the signal is on under real sensorless vector control and vector control. Switching between speed control and torque control is always enabled.

Under vector control, speed control/position control switchover and torque control/position control switchover can be made by setting "4, 5" in Pr. 800. For the terminal used for MC signal input, set "26" in any of Pr. 178 to Pr. 189 "Input terminal function selection" to assign the function.

- When an analog input terminal (terminal 1,4) is used for torque limit, torque command, etc., terminal functions also switch as below if control mode is switched.

### Terminal 1 function according to control

Pr. 868	Real Sensorless Vector Control (Pr. 800 = 12), Vector Control (Pr. 800 = 2)	
	Speed control (MC signal-OFF)	Torque control (MC signal-ON)
0 (initial value)	Speed setting auxiliary	Speed limit auxiliary
1	Magnetic flux command	Magnetic flux command
2	Regenerative torque limit (Pr. 810 = 1)	—
3	—	Torque command (Pr. 804 = 0)
4	Torque limit (Pr. 810 = 1)	Torque command (Pr. 804 = 0)
5	—	Forward reverse speed limit (Pr. 807 = 2)
6	—	—
9999	—	—

**Tab. 6-4:** Terminal 1 function when Pr. 800 = 12 or 2

Pr. 868	Vector Control (Pr. 800 = 4)	
	Speed control (MC signal-OFF)	Position control (MC signal-ON)
0 (initial value)	Speed setting auxiliary	—
1	Magnetic flux command	Magnetic flux command
2	Regenerative torque limit (Pr. 810 = 1)	Regenerative torque limit (Pr. 810 = 1)
3	—	—
4	Torque limit (Pr. 810 = 1)	Torque limit (Pr. 810 = 1)
5	—	—
6	Torque bias	—
9999	—	—

**Tab. 6-5:** Terminal 1 function when Pr. 800 = 4

Pr. 868	Vector Control (Pr. 800 = 5)	
	Position control (MC signal-OFF)	Torque control (MC signal-ON)
0 (initial value)	—	Speed setting auxiliary
1	Magnetic flux command	Magnetic flux command
2	Regenerative torque limit (Pr. 810 = 1)	—
3	—	Torque command (Pr. 804 = 0)
4	Torque limit (Pr. 810 = 1)	Torque command (Pr. 804 = 0)
5	—	Forward reverse speed limit (Pr. 807 = 2)
6	—	—
9999	—	—

**Tab. 6-6:** Terminal 1 function when Pr. 800 = 5

#### Terminal 4 function according to control

Pr. 858	Real Sensorless Vector Control (Pr. 800 = 12), Vector Control (Pr. 800 = 2)	
	Speed control (MC signal-OFF)	Torque control (MC signal-ON)
0 (initial value)	Speed command (AU signal-ON)	Speed limit (AU signal-ON)
1	Magnetic flux command	Magnetic flux command
4	Torque limit (Pr. 810 = 1)	—
9999	—	—

**Tab. 6-7:** Terminal 4 function when Pr. 800 = 12 or 2

Pr. 858	Vector Control (Pr. 800 = 4)	
	Speed control (MC signal-OFF)	Position control (MC signal-ON)
0 (initial value)	Speed command (AU signal-ON)	—
1	Magnetic flux command	Magnetic flux command
4	Torque limit (Pr. 810 = 1)	Torque limit (Pr. 810 = 1)
9999	—	—

**Tab. 6-8:** Terminal 4 function when Pr. 800 = 4

Pr. 858	Vector Control (Pr. 800 = 5)	
	Position control (MC signal-OFF)	Torque control (MC signal-ON)
0 (initial value)	—	Speed limit (AU signal-ON)
1	Magnetic flux command	Magnetic flux command
4	Torque limit (Pr. 810 = 1)	—
9999	—	—

**Tab. 6-9:** Terminal 4 function when Pr. 800 = 5

**NOTES**

Switching between speed control and torque control is always enabled independently of whether the motor is at a stop or running or the DC injection brake operation (pre-excitation).

Speed control/position control switchover and torque control/position control switchover is made when frequency drops to the Pr. 865 "Low speed detection", and not switched during motor operation.

Changing the terminal assignment using Pr. 178 to Pr. 189 "Input terminal function selection" may affect the other functions. Please make setting after confirming the function of each terminal.

## 6.3 Speed control by real sensorless vector control, vector control

Speed control is exercised to match the speed command and actual motor speed.

Purpose	Parameter that should be Set		Refer to Section
To perform torque limit during speed control	Torque limit	Pr. 22, Pr. 803, Pr. 810, Pr. 812–Pr. 817, Pr. 858, Pr. 868, Pr. 874	6.3.2
Gain adjustment of speed control	Easy gain tuning Gain adjustment	Pr. 818–Pr. 821, Pr. 830, Pr. 831, Pr. 880	6.3.3
To enhance the trackability of the motor in response to a speed command change	Speed feed forward control/model adaptive speed control	Pr. 828, Pr. 877–Pr. 881	6.3.4
Stabilize the speed detection signal	Speed detection filter	Pr. 823, Pr. 833	6.6.1
Accelerates the rise of the torque at a start	Torque bias	Pr. 840–Pr. 848	6.3.5
Avoid mechanical resonance	Notch filter	Pr. 862, Pr. 863	6.3.7

### 6.3.1 Selection method of real sensorless vector control (speed control) Sensorless

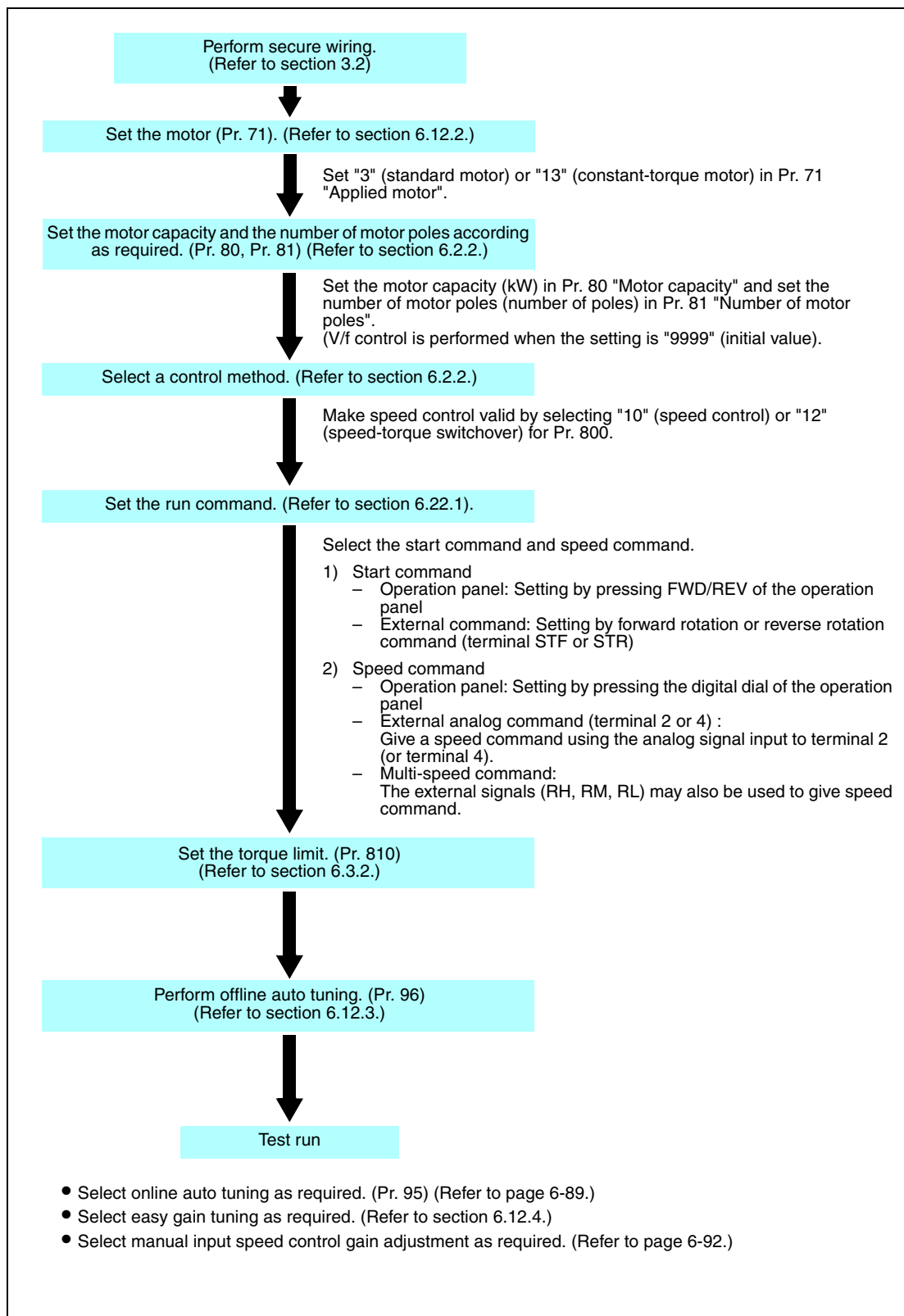

**Fig. 6-5:** Selection of the real sensorless vector control (speed control)

**NOTES**

Make sure to perform offline auto tuning before performing real sensorless vector control.

The carrier frequencies are selectable from among 2k, 6k, 10k, 14kHz for real sensorless vector control.

Torque control can not be performed in the low speed region and at a low speed with light load. Choose vector control.

Do not switch between the STF (forward rotation command) and STR (reverse rotation command) during operation under torque control. Overcurrent shut-off error (E.OC□) or opposite rotation deceleration error (E.11) occurs.

When the inverter is likely to start during motor coasting under real sensorless vector control, set to make frequency search of automatic restart after instantaneous power failure valid (Pr. 57 ≠ 9999, Pr. 162 = 10).

**CAUTION:**

- **Performing pre-excitation (LX signal and X13 signal) under torque control may start the motor running at a low speed even when the start command (STF or STR) is not input. The motor may run also at a low speed when the speed limit value = 0 with a start command input. Perform pre-excitation after making sure that there will be no problem in safety if the motor runs.**
- **For the 00023 to 00126, the speed deviation may become large at 20Hz or less and torque may become insufficient in the low speed region under 1Hz during continuous operation under real sensorless vector control. In such case, stop operation once and reaccelerate to improve the problems.**
- **Enough torque may not be generated in the ultra-low speed range less than approx. 2Hz when performing real sensorless vector control. The guideline of speed control range is as shown below.**

<b>Driving:</b>	1 : 200 (2, 4, 6 poles)	<b>Can be used at 0.3Hz or more at rated 60Hz</b>
	1 : 30 (8, 10 poles)	<b>Can be used at 2Hz or more at rated 60Hz</b>
<b>Regeneration:</b>	1 : 12 (2 bis 10 poles)	<b>Can be used at 5 Hz or more at rated 60 Hz</b>

## Setting procedure of vector control (speed control) Vector

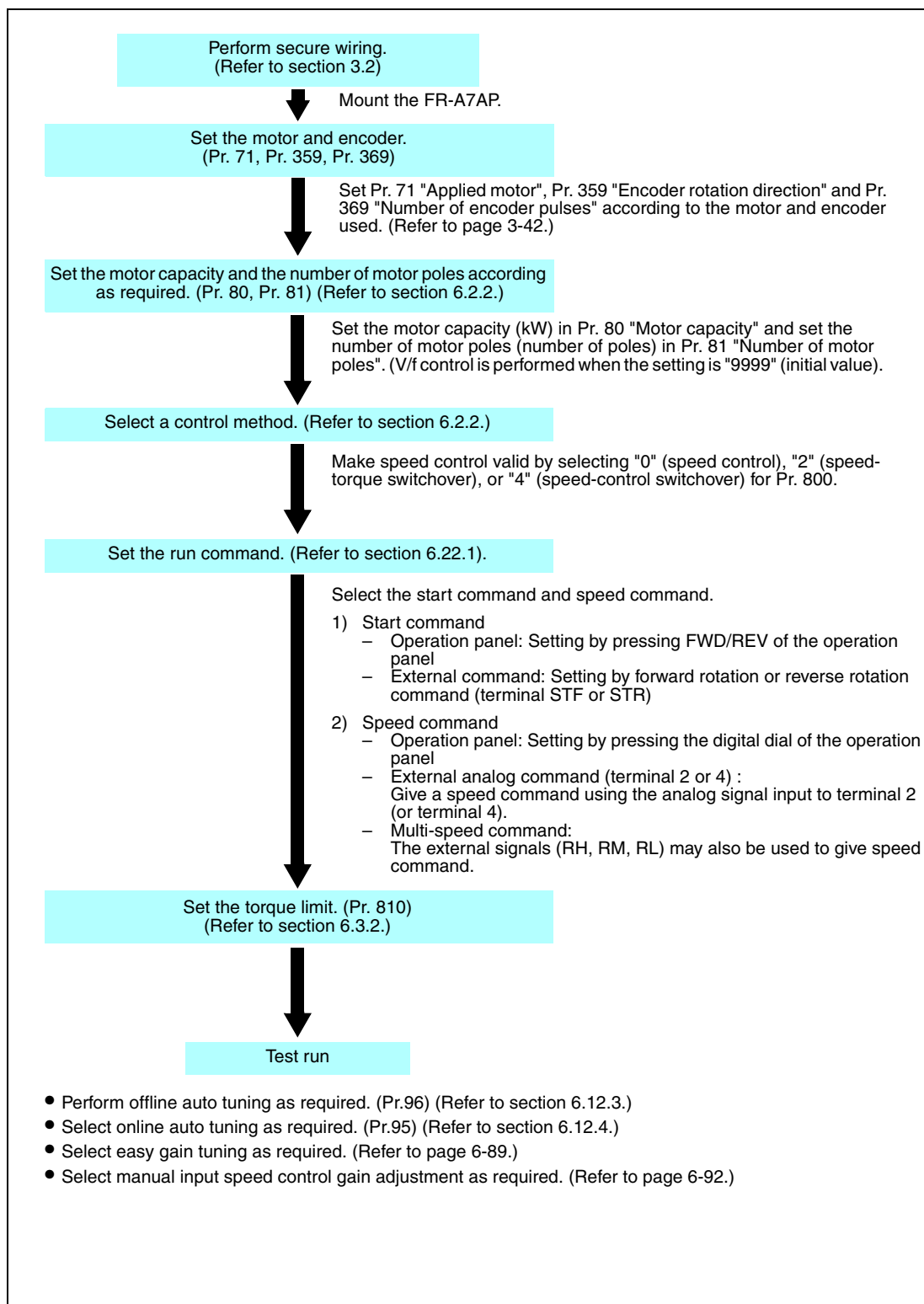

**Fig. 6-6:** Selection of vector control (speed control)

### NOTE

The carrier frequencies are selectable from among 2k, 6k, 10k, 14kHz for vector control.

**6.3.2****Torque limit level setting for speed control****(Pr. 22, Pr. 803, Pr. 810 to Pr. 817, Pr. 858, Pr. 868, Pr. 874)**  

This function limits the output torque to the predetermined value during speed control under real sensorless vector control or vector control.

- Set the torque limit level within the range 0 to 400% in Pr. 22. When the TL signal is turned on, torque limit level 2 functions.
- You can select whether the torque limit level is set using parameters or analog input terminals (terminal 1, 4). In addition, you can set torque limit level for forward (power driving/regeneration) and reverse (power driving/regeneration) operation individually.

**NOTE**

Under real sensorless vector control, the lower limit of torque limit level is set 30% if the value less than 30% is input.



Pr. No.	Name	Initial Value	Setting Range	Description	Parameters referred to	Refer to Section
22	Stall prevention operation level (torque limit level)	150%/200% *	0–400%	Set the torque limit level on the assumption that the rated torque is 100% * For the 00126 or less, the value changes from 150% to 200% when V/f control or advanced magnetic flux vector control is changed to real sensorless vector control or vector control.	22 Stall prevention operation level 178–189 Input terminal function selection) 840 Torque bias selection 865 Low speed detection	6.7.4 6.14.1 6.3.5 6.14.6
803	Constant power range torque characteristic selection	0	0	Constant motor output limit	Select the torque limit in the constant output region by torque limit 1 Constant torque setting.	
			1	Constant torque limit		
810	Torque limit input method selection	0	0	Internal torque limit (torque limit by parameter settings)		
			1	External torque limit (torque limit by terminal 1, 4)		
811	Set resolution switchover ①	0		Speed setting and running speed monitor increments from the PU, RS-485 communication or communication option.	Torque limit setting increments Pr. 22, Pr. 812 to Pr. 817	
			0	1 r/min	0.1%	
			1	0.1 r/min		
			10	1 r/min	0.01%	
			11	0.1 r/min		
812	Torque limit level (regeneration)	9999	0–400%	Set the torque limit level for forward rotation regeneration.		
			9999	Limit at the value of Pr. 22 or analog terminal		
813	Torque limit level (3rd quadrant)	9999	0–400%	Set the torque limit level for reverse rotation driving.		
			9999	Limit at the value of Pr. 22 or analog terminal		
814	Torque limit level (4th quadrant)	9999	0–400%	Set the torque limit level for reverse rotation regeneration.		
			9999	Limit at the value of Pr. 22 or analog terminal		
815	Torque limit level 2	9999	0–400%	When the torque limit selection (TL) signal is on, the Pr. 815 value is a torque limit value regardless of Pr. 810.		
			9999	Limit at the value of Pr. 22 or analog terminal		
816	Torque limit level during acceleration	9999	0–400%	Set the torque limit value during acceleration.		
			9999	Same torque limit as at constant speed		
817	Torque limit level during deceleration	9999	0–400%	Set the torque limit value during deceleration.		
			9999	Same torque limit as at constant speed		
858	Terminal 4 function assignment	0	0/4/9999	When "4" is set in, the torque limit can be changed with a signal to terminal 4.		
868	Terminal 1 function assignment	0	0/2–5/9999	When "4" is set in, the torque limit can be changed with a signal to terminal 1.		
874	OLT level setting	150%	0–200%	This function can make an alarm stop if the torque limit is activated to stall the motor. Set the output at which an alarm stop is made.		

① Setting can be made only when the FR-A7AP is mounted.

**Torque limit block diagram**

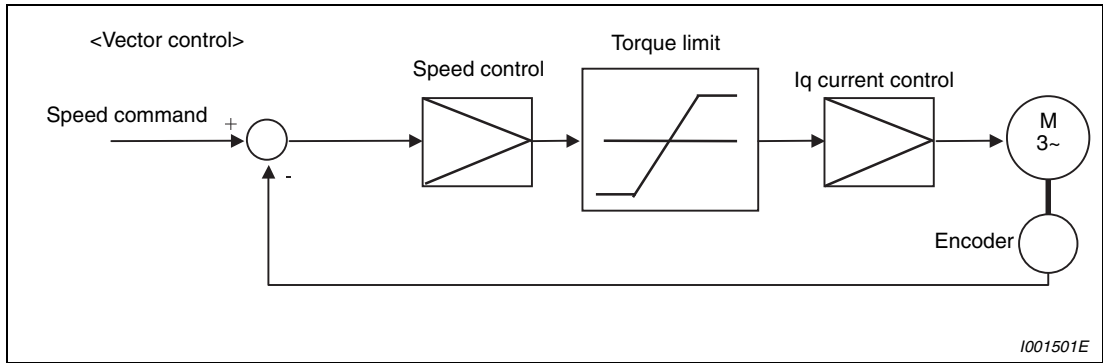

**Fig. 6-7:** Torque limit block diagram

**Selection of torque limit input method (Pr. 810)**

Set Pr. 810 "Torque limit input method selection" to select the method to limit output torque during speed control. Torque limit by parameter setting is initially set.

Pr.	Setting Range	Torque Limit Input Method	Description
810	0 (initial value)	Internal torque limit	Parameter-set torque limit operation is performed. Changing the torque limit parameter value by communication enables torque limit to be input by communication.
	1	External torque limit	Torque limit using the analog voltage (current) from terminal 1 or terminal 4 is made valid.

**Tab. 6-10:** Torque limit input

**Torque limit level by parameter setting (Pr. 810 = 0, Pr. 812 to Pr. 814)**

- In the initial setting, limit is made on all quadrants on the Pr. 22 "Stall prevention operation level (torque limit level)".
- When you want to set the level on a quadrant basis, set the torque limit level in Pr. 812 Torque limit level (regeneration), Pr. 813 "Torque limit level (3rd quadrant)", Pr. 814 "Torque limit level (4th quadrant)". When "9999" is set, Pr. 22 is the torque limit level.

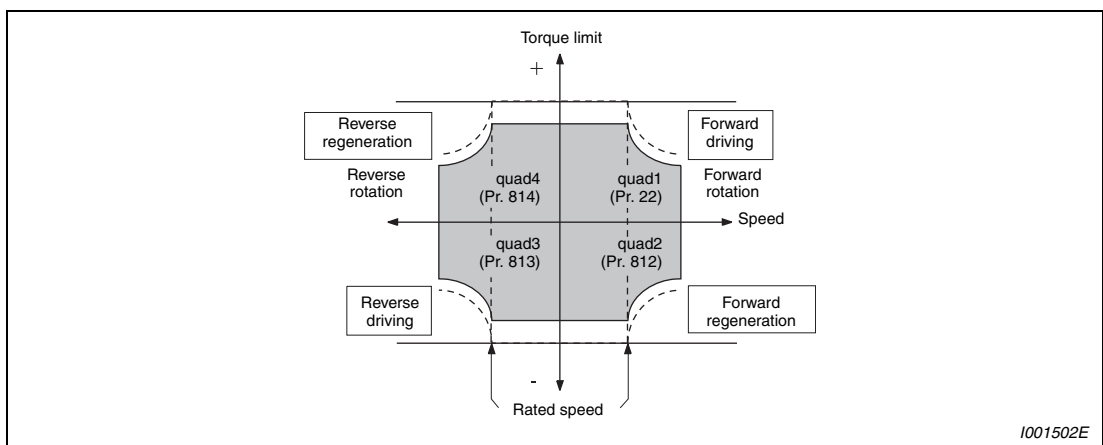

**Fig. 6-8:** Torque limit level by parameter setting

**Torque limit level by analog input (terminal 1, 4) (Pr. 810 = 1, Pr. 858, Pr. 868)**

- With the upper limit of torque limit as set in Pr. 22, the analog input from terminal 1 input is used as the torque limit value within the Pr. 22 setting range.
- When torque limit value is input from terminal 1, set "4" in Pr. 868 "Terminal 1 function assignment". When torque limit value is input from terminal 4, set "4" in Pr. 858 "Terminal 4 function assignment".
- When Pr. 858 = "4" and Pr. 868 = "2", torque is limited by analog input from terminal 1 for regeneration and by terminal 4 for driving.
- Torque limit by analog input can be calibrated using calibration parameter C16 (Pr. 919) to C19 (Pr. 920), C38 (Pr. 932) to C41 (Pr. 933). (Refer to section 6.20.6.)

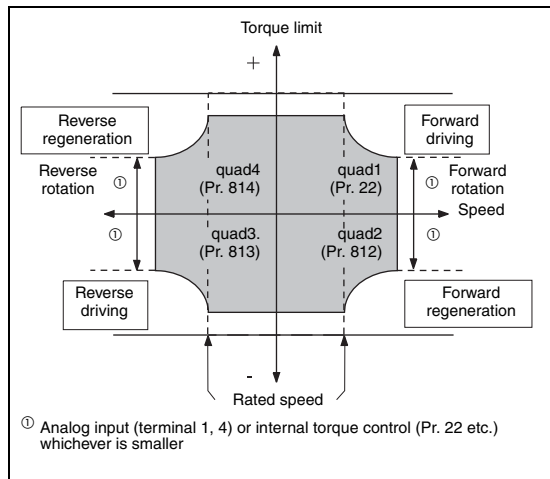

**Fig. 6-9:**  
Torque limit level by analog input

I001503E

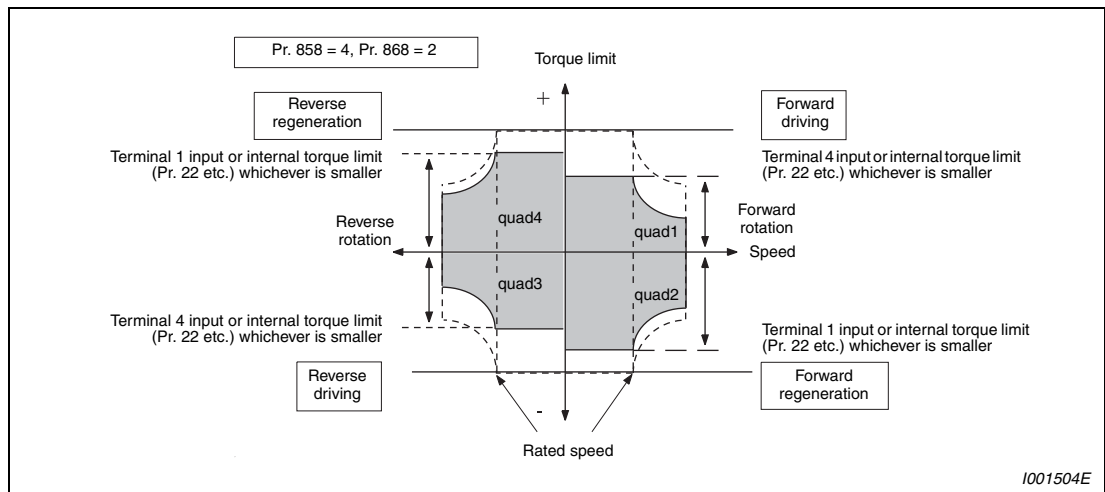

**Fig. 6-10:** Torque limit level by analog input

I001504E

Pr. 858 <sup>①</sup>	Pr. 868 <sup>②</sup>	Real Sensorless Vector Control (Speed Control)	
		Terminal 4 function	Terminal 1 function
0 (initial value)	0 (initial value)	Speed command (AU signal-ON)	Speed setting auxiliary
	1 <sup>④</sup>		Magnetic flux command
	2		—
	3		—
	4		Torque limit (Pr. 810 = 1)
	5		—
	6 <sup>④</sup>		Torque bias (Pr. 840 = 1 to 3)
	9999		—
1 <sup>④</sup>	0 (initial value)	Magnetic flux command	Speed setting auxiliary
	1 <sup>④</sup>	— <sup>③</sup>	Magnetic flux command
	2	Magnetic flux command	—
	3		—
	4		Torque limit (Pr. 810 = 1)
	5		—
	6 <sup>④</sup>		Torque bias (Pr. 840 = 1 to 3)
	9999		—
4 <sup>②</sup>	0 (initial value)	Torque limit (Pr. 810 = 1)	Speed setting auxiliary
	1 <sup>④</sup>	—	Magnetic flux command
	2	Driving torque limit (Pr. 810 = 1)	Regenerative torque limit (Pr. 810 = 1)
	3	Torque limit (Pr. 810 = 1)	—
	4	— <sup>③</sup>	Torque limit (Pr. 810 = 1)
	5	Torque limit (Pr. 810 = 1)	—
	6 <sup>④</sup>		Torque bias (Pr. 840 = 1 to 3)
	9999		—
9999	—	—	—

**Tab. 6-11:** Terminal 1, 4 function according to control

- ① When the Pr. 868 setting is other than "0", other functions of terminal 1 (auxiliary input, override function, PID control) do not function.
- ② When the Pr. 858 setting is other than "0", PID control and speed command from terminal 4 do not function even if the AU signal turns on.
- ③ When "1" (magnetic flux command) or "4" (torque limit) is set in both Pr. 858 and Pr. 868, function of terminal 1 has higher priority and terminal 4 has no function.
- ④ Setting is valid only when exercising vector control with the FR-A7AP.

**Second torque limit level (TL signal, Pr. 815)**

- For Pr. 815 "Torque limit level 2", the Pr. 815 value is a torque limit value regardless of Pr. 810 "Torque limit input method" selection when the torque limit selection signal (TL) is on.
- Set "27" in Pr. 178 to Pr. 189 "Input terminal function selection" to assign a function to the TL signal.

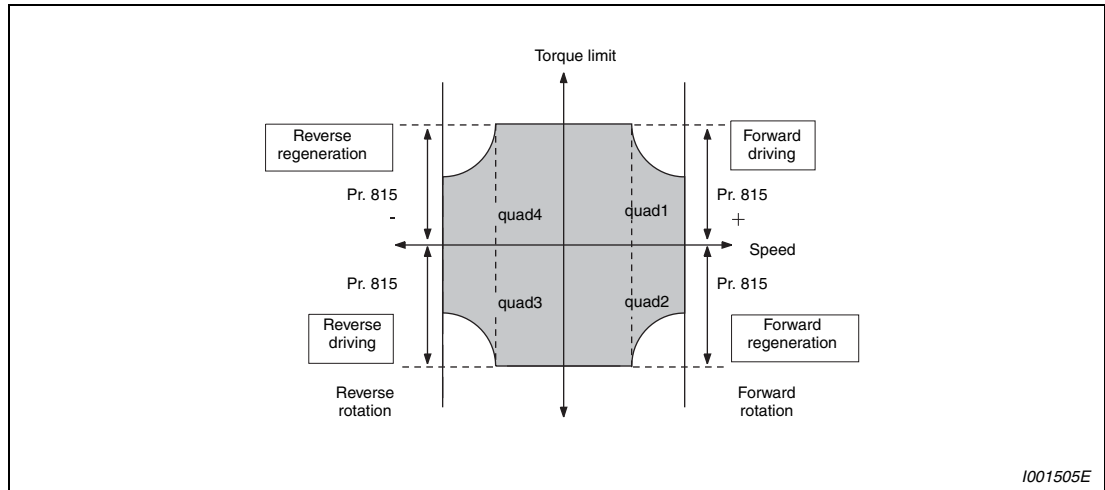

**Fig. 6-11:** Second torque limit level

**NOTE**

Changing the terminal assignment using Pr. 178 to Pr. 189 "Input terminal function selection" may affect the other functions. Please make setting after confirming the function of each terminal.

**Set a torque limit value during acceleration and deceleration individually (Pr. 816, Pr. 817)**

You can set torque limit during acceleration and deceleration individually.

The following chart shows torque limit according to the settings of Pr. 816 "Torque limit level during acceleration" and Pr. 817 "Torque limit level during deceleration".

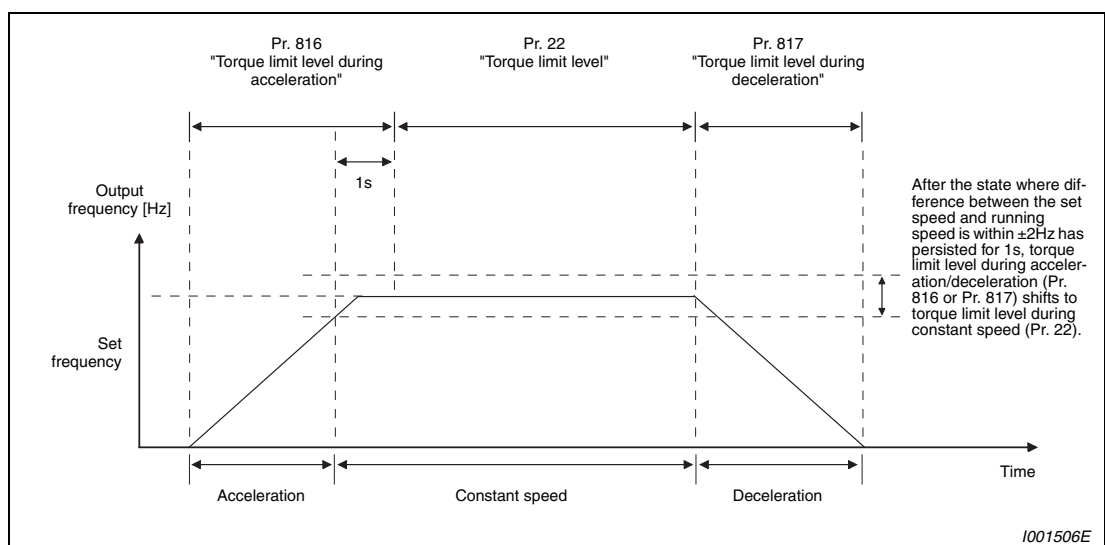

### Setting increments switchover of the torque limit level (Pr. 811)

By setting "10, 11" in Pr. 811 "Set resolution switchover", the setting increments of Pr. 22 "Torque limit level" and Pr. 812 to Pr. 817 "Torque limit level" can be switched to 0.01%.

#### NOTES

The internal resolution of the torque limit is 0.024% ( $100/2^{12}$ ) and the fraction less than the resolution is rounded off.

When the torque limit setting increments have been changed (0.1%  $\leftrightarrow$  0.01%), reset is necessary because the settings of Pr. 22 and Pr. 812 to Pr. 817 are multiplied by 1/10 (ten times).

For example, when 10 (0.01%) set in Pr. 811 is changed to 1 (0.1%) with Pr. 22 = 150.00%, Pr. 22 = 1500.0% and the maximum torque is 400%.

Refer to section 6.15.1 for switchover of speed setting increments.

### Change the torque characteristics in the constant power range (Pr. 803)

You can select whether the torque limit in the constant power range be constant torque limit (setting is "1") or constant power limit (initial setting is "0"), using Pr. 803 "Constant power range torque characteristic selection" under torque limit operation.

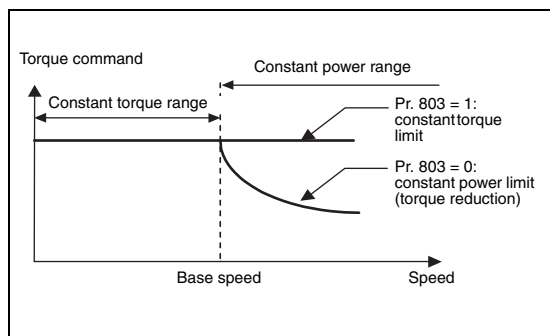
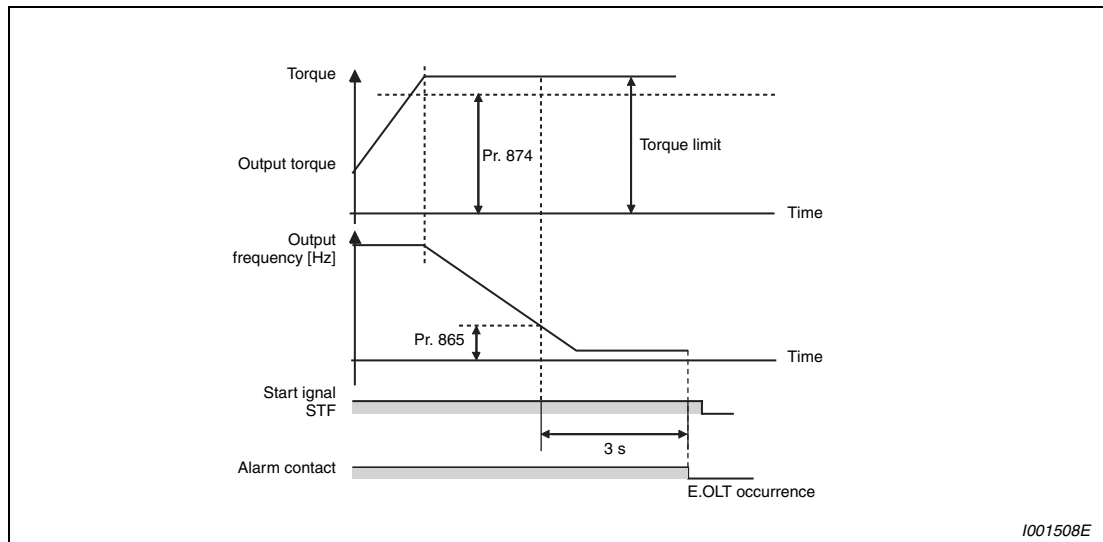

**Fig. 6-13:**  
Torque characteristics in the constant power range

1001507E

**Alarm stop when torque limit is activated (Pr. 874 )**

- This function can make an alarm stop if the torque limit is activated to stall the motor.
- The motor stalls if the torque limit is activated under a high load applied during speed control or position control. At this time, if the motor speed is lower than the speed set in Pr. 865 "Low speed detection" and also the output torque exceeds the level set in Pr. 874 "OLT level setting" for 3s, it is regarded as a stop effected by stall prevention and E. OLT is output, resulting in an alarm stop.



**Fig. 6-14:** Alarm stop when torque limit is activated

**NOTES**

If the frequency has fallen to 0.5Hz by stall prevention operation and remains for 3s under V/f control and advanced magnetic flux vector control, an alarm (E.OLT) appears to shutoff the inverter output. In this case, this function is activated regardless of Pr. 874.

This alarm is not provided under torque control.

### 6.3.3 To perform high accuracy/fast response operation (gain adjustment of real sensorless vector control and vector control) (Pr. 818 to Pr. 821, Pr. 830, Pr. 831, Pr. 880) Sensorless Vector

The ratio of the load inertia to the motor inertia (load inertia moment) is estimated in real time from the torque command and speed during motor operation by vector control. As optimum gain of speed control and position control are automatically set from the load inertia ratio and response level, time and effort of making gain adjustment are reduced. (Easy gain tuning)

When the load inertia ratio can not be estimated due to load fluctuation or real sensorless vector control is exercised, control gain is automatically set by manually inputting the load inertia ratio. Make a manual input adjustment when vibration, noise or any other unfavorable phenomenon occurs due to large load inertia or gear backlash, for example, or when you want to exhibit the best performance that matches the machine.

Pr. No.	Name	Initial Value	Setting Range	Description	Parameters referred to	Refer to Section
<b>818</b>	Easy gain tuning response level setting	2	1–15	Set the response level. 1: Slow response to 15: Fast response	—	
<b>819</b>	Easy gain tuning selection	0	0	Without easy gain tuning		
			1	With load estimation, with gain calculation (valid only during vector control)		
			2	With load (Pr. 880) manual input, gain calculation		
<b>820</b>	Speed control P gain 1	60%	0–1000%	Set the proportional gain for speed control. (Increasing the value improves trackability in response to a speed command change and reduces speed variation with disturbance.)		
<b>821</b>	Speed control integral time 1	0.333s	0–20s	Set the integral time during speed control. (Decrease the value to shorten the time taken for returning to the original speed if speed variation with disturbance occurs.)		
<b>830</b>	Speed control P gain 2	9999	0–1000%	Second function of Pr. 820 (valid when RT signal is on)		
			9999	No function		
<b>831</b>	Speed control integral time 2	9999	0–20s	Second function of Pr. 821 (valid when RT signal is on)		
			9999	No function		
<b>880</b>	Load inertia ratio	7	0–200	Set the load inertia ratio to the motor.		



**Block diagram of easy gain tuning function**

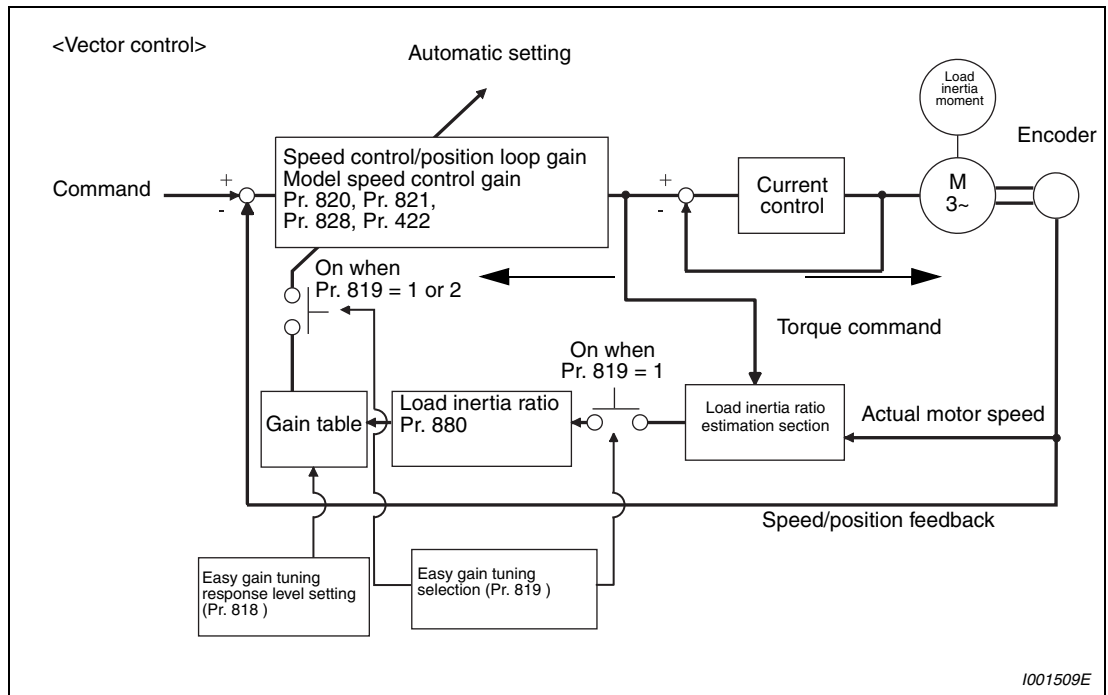
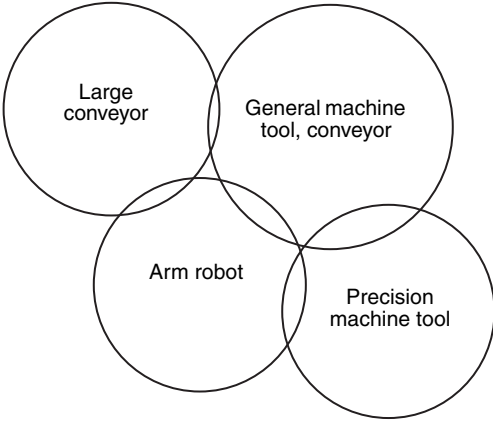

**Fig. 6-15:** Block diagram of easy gain tuning function

**Easy gain tuning execution procedure (Pr. 819 = 1 load inertia ratio automatic estimation)**

Easy gain tuning (load inertia ratio automatic estimation) is valid only in the speed control or position control mode under vector control. It is invalid under torque control, V/f control, advanced magnetic flux vector control and real sensorless vector control.

- ① Set the response level using Pr. 818 "Easy gain tuning response level setting". Refer to the diagram below and set the response level. Increasing the value will improve trackability to the command, but too high value will generate vibration.

Pr. 818	1	2	3	4	5	6	7	8	9	10	11	12	13	14	15
Response level	Slow response					Middle response					Fast response				
Guideline of machine resonance frequency [Hz]	8	10	12	15	18	22	28	34	42	52	64	79	98	122	150
Application															

1001482E

**Tab. 6-12:** Response level setting

- ② Each control gain is automatically set from the load inertia ratio estimated during acceleration/deceleration operation and the Pr. 818 "Easy gain tuning response level setting" value. Pr. 880 "Load inertia ratio" is used as the initial value of the load inertia ratio for tuning. Estimated value is set in Pr. 880 during tuning. The load inertia ratio may not be estimated well, e.g. it takes a long time for estimation, if the following conditions are not satisfied.
- Time taken for acceleration/deceleration to reach 1500r/min is 5s or less.
  - Speed is 150r/min or more.
  - Acceleration/deceleration torque is 10% or more of the rated torque.
  - Abrupt disturbance is not applied during acceleration/deceleration.
  - Load inertia ratio is approx. 30 times or less.
  - No gear backlash nor belt looseness is found.
- ③ Press the FWD or REV key to estimate the load inertia ratio or calculate gain any time. (The operation command for external operation is the STF or STR signal.)

Easy gain tuning execution procedure (Pr. 819 = 2 load inertia manual input)

Easy gain tuning (load inertia ratio manual input) is valid only in the speed control under real sensorless vector control or in the speed control or position control mode under vector control.

- ① Set the load inertia ratio to the motor in Pr. 880 "Load inertia ratio".
- ② Set "2" (with easy gain tuning) in Pr. 819 "Easy gain tuning selection". Then, Pr. 820 "Speed control P gain 1" and Pr. 821 "Speed control integral time 1" are automatically set by gain calculation. Operation is performed in a gain adjusted status from the next operation.
- ③ Perform a test run and set the response level in Pr. 818 "Easy gain tuning response level setting". Increasing the value will improve trackability to the command, but too high value will generate vibration. (When "2" (parameter write enabled during operation) is set in Pr. 77 "Parameter write selection", response level adjustment can be made during operation.)

**NOTES**

When "1 or 2" is set in Pr. 819 and then returned the Pr. 819 setting to "0" after tuning is executed, tuning results which are set in each parameter remain unchanged.

When good tuning accuracy is not obtained after executing easy gain tuning due to disturbance and such, perform fine adjustment by manual input. Set "0" (without easy gain tuning) in Pr. 819.

The following table indicates the relationship between easy gain tuning function and gain adjustment parameter.

	Easy Gain Tuning Selection (Pr. 819 ) Setting		
	0	1	2
Load inertia ratio (Pr. 880)	Manual input	a) Inertia estimation result (RAM) by easy gain tuning is displayed. b) Set the value in the following cases: <ul style="list-style-type: none"> <li>● Every hour after power-on</li> <li>● When a value other than "1" is set in Pr. 819</li> <li>● When vector control is changed to other control (V/f control etc.) using Pr. 800</li> </ul> c) Write is enabled only during a stop (manual input)	Manual input
Speed control P gain 1 (Pr. 820) Speed control integral time 1 (Pr. 821) Model speed control gain (Pr. 828) Position loop gain (Pr. 422)	Manual input	a) Tuning result (RAM) is displayed. b) Set the value in the following cases: <ul style="list-style-type: none"> <li>● Every hour after power-on</li> <li>● When a value other than "1" is set in Pr. 819</li> <li>● When vector control is changed to other control (V/f control etc.) using Pr. 800</li> </ul> c) Write (manual input) disabled	a) Gain and integral time is calculated when "2" is set in Pr. 819 and the result is set in the parameter. b) When the value is read, the tuning result (parameter setting value) is displayed. c) Write (manual input) disabled

**Tab. 6-13:** Automatically set parameters by easy gain tuning



**CAUTION:**

*Performing easy gain tuning with larger inertia than the specified value during vector control may cause malfunction such as hunting. In addition, when the motor shaft is fixed with servo lock or position control, bearing may be damaged. To prevent these, make gain adjustment by manual input without performing easy gain tuning.*

**Manual input speed control gain adjustment**

Make adjustment when any of such phenomena as unusual machine vibration/noise, low response level and overshoot has occurred.

- Pr. 820 "Speed control P gain 1" = 60% (initial value) is equivalent to 120rad/s (speed response of the motor alone). Increasing the setting value improves the response level, but a too large gain will produce vibration and/or unusual noise.

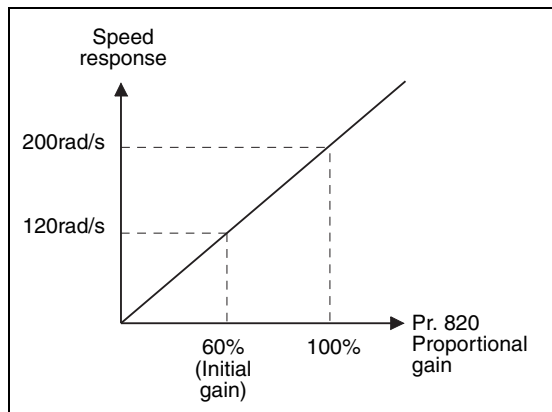

**Fig. 6-16:**  
Setting of the proportional gain

1001483E

- Decreasing the Pr. 821 "Speed control integral time 1" shortens the return time taken at a speed change. However, a too short time will generate an overshoot.
- When there is load inertia, the actual speed gain is as given below.

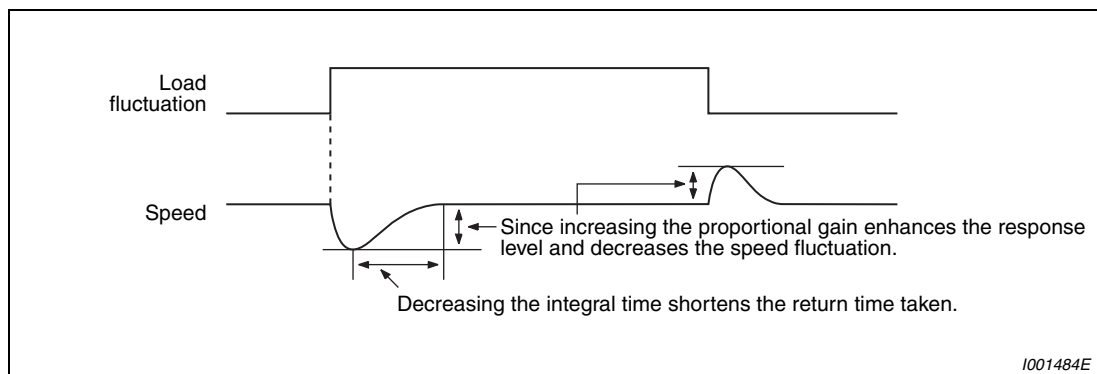

1001484E

**Fig. 6-17:** Speed characteristic at load fluctuation

Also, when there is load inertia, the actual speed gain decreases as indicated below.

$$\text{Actual speed gain} \blacksquare \text{ speed gain of motor without load} \times \frac{JM}{JM + JL}$$

JM: Inertia of the motor  
JL: Motor shaft-equivalent load inertia

- Adjustment procedures are as below:  
Check the conditions and simultaneously change the Pr. 820 value.  
If you cannot make proper adjustment, change the Pr. 821 value and repeat the step above.

No	Phenomenon/Condition	Adjustment Method	
1	Load inertia is large	Set the Pr. 820 and Pr. 821 values a little higher.	
		Pr. 820	When a speed rise is slow, increase the value 10% by 10% until just before vibration/noise is produced, and set about 0.8 to 0.9 of that value.
		Pr. 821	If an overshoot occurs, double the value until an overshoot does not occur, and set about 0.8 to 0.9 of that value.
2	Vibration/noise generated from mechanical system	Set the Pr. 820 value a little lower and the Pr. 821 value a little higher.	
		Pr. 820	Decrease the value 10% by 10% until just before vibration/noise is not produced, and set about 0.8 to 0.9 of that value.
		Pr. 821	If an overshoot occurs, double the value until an overshoot does not occur, and set about 0.8 to 0.9 of that value.
3	Slow response	Set the Pr. 820 value a little higher.	
		Pr. 820	When a speed rise is slow, increase the value 5% by 5% until just before vibration/noise is produced, and set about 0.8 to 0.9 of that value.
4	Long return time (response time)	Set the Pr. 821 value a little lower.	
		Decrease the Pr. 821 value by half until just before an overshoot or the unstable phenomenon does not occur, and set about 0.8 to 0.9 of that value.	
5	Overshoot or unstable phenomenon occurs	Set the Pr. 821 value a little higher.	
		Double the Pr. 821 value until just before an overshoot or the unstable phenomenon does not occur, and set about 0.8 to 0.9 of that value.	

**Tab. 6-14:** Adjustment procedures for parameter 820 and 821

#### NOTES

When making manual input gain adjustment, set "0" (without easy gain tuning) (initial value) in Pr. 819 "Easy gain tuning selection".

Pr. 830 "Speed control P gain 2" and Pr. 831 "Speed control integral time 2" are made valid when the RT terminal is switched on. Make adjustments in the same way as Pr. 820 and Pr. 821.

**When using a multi-pole motor (8 poles or more)**

Specially when using a multi-pole motor with more than 8 poles under vector control (with encoder, real sensorless), adjust speed control P gain (Pr. 820) and torque control P gain (Pr. 824) according to the motor referring to the following methods.

- For speed control P gain Pr. 820, increasing the setting value improves the response level, but a too large gain will produce vibration and/or unusual noise.
- For torque control P gain Pr. 824, note that a too low value will produce current ripples, causing the motor to generate sound synchronizing the cycle of current ripples.

No.	Phenomenon/Condition	Adjustment Method
1	The motor rotation is unstable in the low speed range.	Set a higher value in Pr. 820 "Speed control P gain 1" according to the motor inertia. Since the self inertia of a multi-pole motor tends to become large, make adjustment to improve the unstable phenomenon, then make fine adjustment in consideration of the response level using that setting as reference. In addition, when performing vector control with encoder, gain adjustment according to the inertia can be easily done using easy gain tuning (Pr. 819 = 1).
2	Speed trackability is poor	Set a higher value in Pr. 820 "Speed control P gain 1".
3	Speed variation at the load fluctuation is large	Increase the value 10% by 10% until just before vibration or unusual noise is produced, and set about 0.8 to 0.9 of that value. If you cannot make proper adjustment, increase the value of Pr. 821 "Speed control integral time 1" double by double and make adjustment of Pr. 820 again.
4	Torque becomes insufficient or torque ripple occurs at starting or in the low speed range under real sensorless vector control.	Set the speed control gain a little higher. (same as No. 1) If the problem still persists after gain adjustment, increase Pr. 13 "Starting frequency" or set the acceleration time shorter if the inverter is starting to avoid continuous operation in the ultra low speed range.
5	Unusual motor and machine vibration, noise or overcurrent occurs.	Set a lower value in Pr. 824 "Torque control P gain 1". Decrease the value 10% by 10% until just before the phenomenon is improved, 6 and set about 0.8 to 0.9 of that value.
6	Overcurrent or overspeed (E.OS) occurs at a start under real sensorless vector control.	

**Tab. 6-15: Adjustment method**

**P/PI switchover (X44 signal)**

- By turning the P/PI control switching signal (X44) on/off during seed control operation under real sensorless vector control or vector control, you can select whether to add the integral time (I) or not when performing gain adjustment with P gain and integral time.

When the X44 signal is off PI control

When the X44 signal is on P control

- For the terminal used for X44 signal input, set "44" in any of Pr. 178 to Pr. 189 "Input terminal function selection" to assign the function.

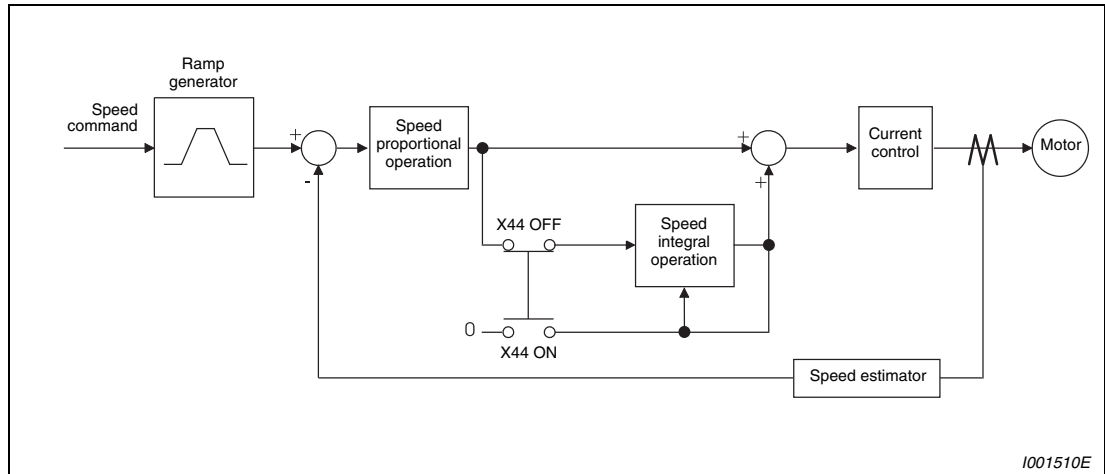
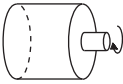
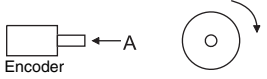
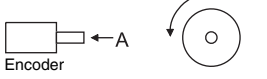
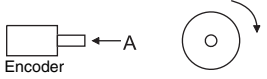
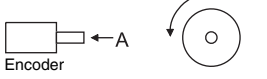
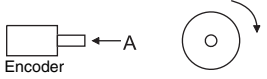
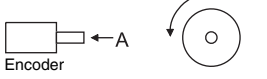

**Fig. 6-18:** Function block diagram]

**NOTE**

Changing the terminal assignment using Pr. 178 to Pr. 189 "Input terminal function selection" may affect the other functions. Make setting after confirming the function of each terminal.

**Troubleshooting**

	Phenomenon	Cause	Countermeasures						
1	Motor does not rotate. (Vector control)	<p>(1) The motor wiring is wrong</p> <p>(2) Encoder specifications (encoder specification selection switch FR-A7AP) are wrong</p> <p>(3) The encoder wiring is wrong.</p> <p>(4) The Pr. 369 "Number of encoder pulses" setting and the number of encoder used are different.</p> <p>(5) Encoder power specifications are wrong. Or, power is not input.</p>	<p>(1) Wiring check Select V/f control (Pr. 800 = 20) and check the rotation direction of the motor. Check the speed monitor output from output terminal CA. For the FR-V5RU, set "340V" for 3.7kW or less and "320V " for more in Pr. 19 "Base frequency voltage", and set "50Hz" in Pr. 3 "Base frequency".</p> <p>When the forward rotation signal is input, the motor running in the clockwise direction as viewed from the motor shaft is normal. (If it runs in the clockwise direction, the phase sequence of the inverter secondary side wiring is incorrect.)</p>  <p>(2) Check the encoder specifications. Check the encoder specifications selection switch (FR-A7AP) of differential/complimentary.</p> <p>(3) Check that FWD is displayed when running the motor in the clockwise direction from outside during a stop of the inverter with vector control setting. If REV is displayed, the encoder phase sequence is wrong. Perform the correct wiring or match the Pr. 359 "Encoder rotation direction"..</p> <table border="1" data-bbox="1007 1055 1423 1435"> <thead> <tr> <th data-bbox="1007 1055 1139 1115">Pr. 359</th> <th data-bbox="1139 1055 1423 1115">Relationship between the motor and encoder</th> </tr> </thead> <tbody> <tr> <td data-bbox="1007 1115 1139 1267">0</td> <td data-bbox="1139 1115 1423 1267">  <p>Clockwise direction as viewed from A is forward rotation</p> </td> </tr> <tr> <td data-bbox="1007 1267 1139 1435">1 (Initial value)</td> <td data-bbox="1139 1267 1423 1435">  <p>Counter clockwise direction as viewed from A is forward rotation</p> </td> </tr> </tbody> </table> <p>(4) The motor will not run if the parameter setting is smaller than the number of encoder pulses used. Set the Pr. 369 "Number of encoder pulses" correctly.</p> <p>(5) Check the power specifications (5V/12V/15V/24V) of encoder and input the external power supply.</p>	Pr. 359	Relationship between the motor and encoder	0	 <p>Clockwise direction as viewed from A is forward rotation</p>	1 (Initial value)	 <p>Counter clockwise direction as viewed from A is forward rotation</p>
Pr. 359	Relationship between the motor and encoder								
0	 <p>Clockwise direction as viewed from A is forward rotation</p>								
1 (Initial value)	 <p>Counter clockwise direction as viewed from A is forward rotation</p>								

**Tab. 6-16: Troubleshooting (1)**



	Phenomenon	Cause	Countermeasures
2	Motor does not run at correct speed. (Speed command does not match actual speed)	<p>(1) The speed command from the command device is incorrect. The speed command is compounded with noise.</p> <p>(2) The speed command value does not match the inverter-recognized value.</p> <p>(3) The number of encoder pulses setting is incorrect.</p>	<p>(1) Check that a correct speed command comes from the command device. Decrease Pr. 72 "PWM frequency selection".</p> <p>(2) Readjust speed command bias/gain Pr. 125, Pr. 126, C2 to C7 and C12 to C15.</p> <p>(3) Check the setting of Pr. 369 "Number of encoder pulses". (vector control)</p>
3	Speed does not rise to the speed command.	<p>(1) Insufficient torque. Torque limit is actuated.</p> <p>(2) Only P (proportional) control is selected.</p>	<p>(1)-1 Increase the torque limit value. (Refer to torque limit of speed control in section 6.3.2.)</p> <p>(1)-2 Insufficient capacity</p> <p>(2) When the load is heavy, speed deviation will occur under P (proportional) control. Select PI control.</p>
4	Motor speed is unstable.	<p>(1) The speed command varies.</p> <p>(2) Insufficient torque.</p> <p>(3) The speed control gains do not match the machine. (machine resonance)</p>	<p>(1)-1 Check that a correct speed command comes from the command device. (Take measures against noises.)</p> <p>(1)-2 Decrease Pr. 72 "PWM frequency selection".</p> <p>(1)-3 Increase Pr. 822 "Speed setting filter 1". (Refer to section 6.20.4.)</p> <p>(2) Increase the torque limit value. (Refer to torque limit of speed control in section 6.3.2.)</p> <p>(3)-1 Perform easy gain tuning. (Refer to page 6-89).</p> <p>(3)-2 Adjust Pr. 820, Pr. 821. (Refer to page 6-92).</p> <p>(3)-3 Perform speed feed forward/model adaptive speed control.</p>
5	Motor or machine hunts (vibration/noise is produced).	<p>(1) The speed control gain is high.</p> <p>(2) The torque control gain is high.</p> <p>(3) The motor wiring is wrong.</p>	<p>(1)-1 Perform easy gain tuning. (Refer to page 6-89).</p> <p>(1)-2 Decrease Pr. 820 and increase Pr. 821.</p> <p>(1)-3 Perform speed feed forward control and model adaptive speed control.</p> <p>(2) Decrease the Pr. 824 value. (Refer to section 6.4.7.)</p> <p>(3) Check the wiring.</p>

**Tab. 6-16: Troubleshooting (2)**

	Phenomenon	Cause	Countermeasures
6	Acceleration/deceleration time does not match the setting.	(1) Insufficient torque.  (2) Large load inertia.	(1)-1 Increase the torque limit value. (Refer to torque limit of speed control in section 6.3.2.) (1)-2 Perform speed feed forward control. (2) Set the acceleration/deceleration time that meets the load.
7	Machine operation is unstable	(1) The speed control gains do not match the machine.  (2) Slow response because of improper acceleration/deceleration time of the inverter.	(1)-1 Perform easy gain tuning. (Refer to section 6-89). (1)-2 Adjust Pr. 820, Pr. 821. (Refer to page 6-92). (1)-3 Perform speed feed forward control and model adaptive speed control. (2) Change the acceleration/deceleration time to an optimum value.
8	Speed fluctuates at low speed.	(1) Adverse effect of high carrier frequency. (2) Low speed control gain.	(1) Decrease Pr. 72 "PWM frequency selection". (2) Increase Pr. 820 "Speed control P gain 1".

**Tab. 6-16: Troubleshooting (3)**

### 6.3.4 Speed feed forward control, model adaptive speed control (Pr. 828, Pr. 877 to Pr. 881) Sensorless Vector

By making parameter setting, select the speed feed forward control or model adaptive speed control.

The speed feed forward control enhances the trackability of the motor in response to a speed command change.

The model adaptive speed control enables individual adjustment of speed trackability and motor disturbance torque response.

Pr. No.	Name	Initial Value	Setting Range	Description
<b>828</b>	Model speed control gain	60%	0–1000%	Set the gain for model speed controller.
<b>877</b>	Speed feed forward control/ model adaptive speed control selection	0	0	Normal speed control is exercised.
			1	Speed feed forward control is exercised.
			2	Model adaptive speed control is enabled.
<b>878</b>	Speed feed forward filter	0 s	0–1s	Set the primary delay filter for the speed feed forward result calculated using the speed command and load inertia ratio.
<b>879</b>	Speed feed forward torque limit	150%	0–400%	Limits the maximum value of the speed feed forward torque.
<b>880</b>	Load inertia ratio	7	0–200	Set the load inertia ratio to the motor.
<b>881</b>	Speed feed forward gain	0%	0–1000%	Set the feed forward calculation result as a gain.

Parameters referred to	Refer to Section
820 Speed control P gain 1	6.3.3
830 Speed control P gain 2	6.3.3
821 Speed control integral time 1	6.3.3
831 Speed control integral time 2	6.3.3

**NOTE**

When model adaptive speed control is selected, the data obtained from easy gain tuning is used for Pr. 828 "Model speed control gain". Perform easy gain tuning also (simultaneously). (Refer to page 6-89.)

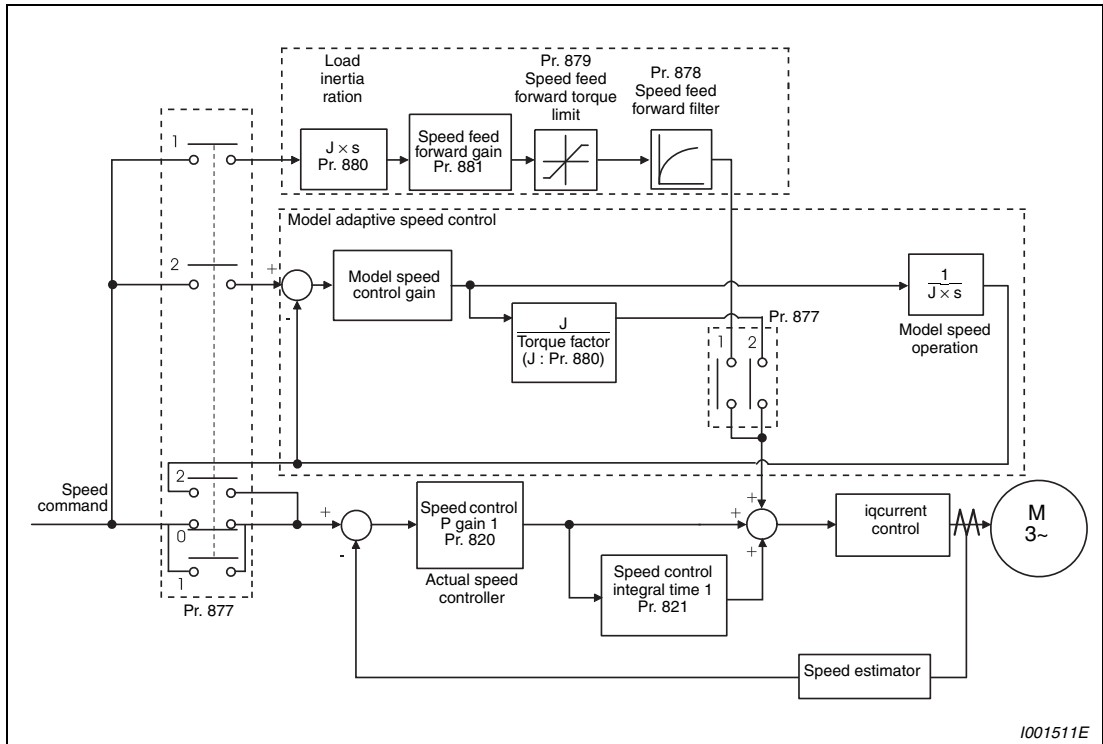

Fig. 6-19: Block diagram

**Speed feed forward control (Pr. 877 = 1)**

- Calculate required torque in response to the acceleration/deceleration command for the inertia ratio set in Pr. 880 and generate torque immediately.
- When the speed feed forward gain is 100%, the calculation result of the speed feed forward is reflected as-is.
- If the speed command changes suddenly, large torque is generated due to the speed feed forward calculation. The maximum value of the speed feed forward is limited using Pr. 879.
- Using Pr. 878, the speed feed forward result can be dulled by the primary delay filter.

**Model adaptive speed control (Pr. 877 = 2)**

- The motor's model speed is calculated to feed back the model side speed controller. This model speed is also used as the actual speed controller command.
- The inertia ratio in Pr. 880 is used for calculation of the torque current command value given by the model side speed controller.
- The torque current command value of the model side speed controller is added to the output of the actual speed controller, and the result is used as the iq current control input. Pr. 828 is used for model side speed control (P control), and the first gain in Pr. 820 is used for the actual speed controller. The model adaptive speed control is valid for the first motor only.
- When Pr. 877 = 2, switching to the second motor handles the second motor as Pr. 877 = 0.

**NOTE**

The adequate gain value for the model and actual loop parts are set according to the response setting of easy gain tuning under model adaptive speed control. To increase the response level, the Pr. 818 "Easy gain tuning response level setting" needs to be changed (increased).

**Combination of easy gain tuning**

The following table indicates the relationships between the speed feed forward/model adaptive speed control and easy gain tuning function.

	Easy Gain Tuning Selection (Pr. 819) Setting		
	0	1	2
Load inertia ratio (Pr. 880)	Manual input	Inertia ratio estimation value found by easy gain tuning is displayed. Manual input enabled only during a stop.	Manual input
Speed control P gain 1 (Pr. 820)	Manual input	Tuning results are displayed. Write disabled	Tuning results are displayed. Write disabled
Speed control integral time 1 (Pr. 821)	Manual input	Tuning results are displayed. Write disabled	Tuning results are displayed. Write disabled
Model speed control gain (Pr. 828)	Manual input	Tuning results are displayed. Write disabled	Tuning results are displayed. Write disabled
Speed feed forward gain (Pr. 881)	Manual input	Manual input	Manual input

**Tab. 6-17:** *Combination of easy gain tuning*

### 6.3.5 Torque biases (Pr. 840 to Pr. 848) Vector

This function accelerates the rise of the torque at a start. Adjust the torque at a motor start using the contact signals or analog signals.

Pr. No.	Name	Initial Value	Setting Range	Description	Parameters referred to	Refer to Section
<b>840</b>	Torque bias selection	9999	0	Set the torque bias amount with the contact signal (X42, X43) using Pr. 841 to Pr. 843.	73 Analog input selection 178–189 Input terminal function selection) C16–C19 Torque setting voltage (current) bias and gain	6.20.2 6.14.1 6.20.6
			1	Set the terminal 1-based torque bias amount as desired in C16 to C19. (in the case a cage goes up when a motor runs reversely)		
			2	Set the terminal 1-based torque bias amount as desired in C16 to C19. (in the case a cage goes up when a motor runs forward)		
			3	The terminal 1-based torque bias amount can be set automatically in C16 to C19, Pr. 846 according to the load.		
			9999	Without torque bias, rated torque 100%		
<b>841</b>	Torque bias 1	9999	600–999%	Negative torque bias amount (–400% to –1%)		
<b>842</b>	Torque bias 2		1000–1400%	Positive torque bias amount (0 % to 400 %)		
<b>843</b>	Torque bias 3		9999	Without torque bias setting		
<b>844</b>	Torque bias filter	9999	0–5s	Time until torque rises.		
			9999	Same operation as when 0s is set.		
<b>845</b>	Torque bias operation time	9999	0–5s	Time for maintaining torque equivalent to the torque bias amount.		
			9999	Same operation as when 0s is set.		
<b>846</b>	Torque bias balance compensation	9999	0–10V	Set the voltage under balanced load.		
			9999	Same operation as when 0V is set.		
<b>847</b>	Fall-time torque bias terminal 1 bias	9999	0–400%	Set the bias value of the torque command.		
			9999	Same as at a rise time (C16, C17 (Pr. 919)).		
<b>848</b>	Fall-time torque bias terminal 1 gain	9999	0–400%	Set the gain value of the torque command.		
			9999	Same as at a rise time (C18, C19 (Pr. 920)).		

The above parameters can be set when the FR-A7AP (option) is mounted.

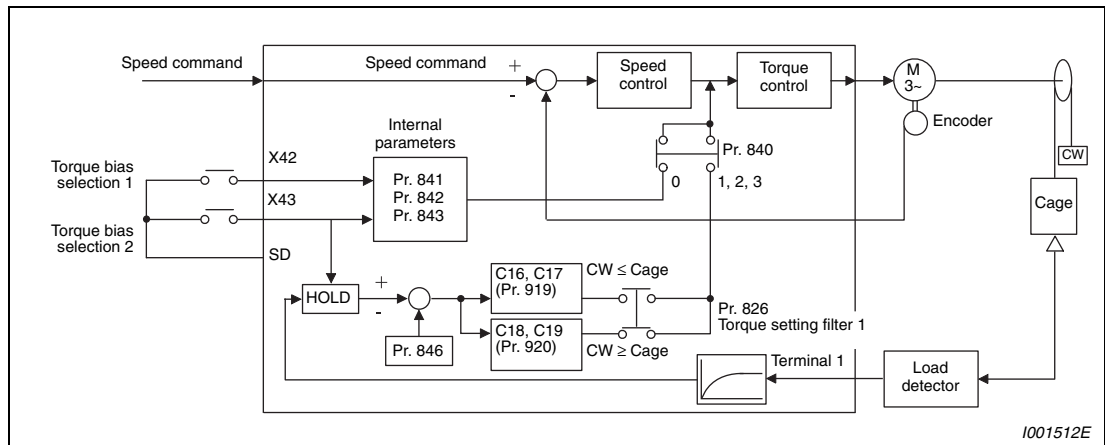

Fig. 6-20: Block diagram

**Setting torque bias amount with the contact input (Pr. 840 = 0)**

- Select the torque bias amount in the table below according to the combination of contact signals.
- Set "42" in Pr. 178 to Pr. 189 "Input terminal function selection" for the terminal used for X42 signal input and set "43" for the terminal used for X43 signal input to assign functions.

Torque Bias Selection 1 (X42)	Torque Bias Selection 2 (X43)	Torque Bias Amount
OFF	OFF	0%
ON	OFF	Pr. 841: -400% to +400% (Setting value: 600 to 1400)
OFF	ON	Pr. 842: -400% to +400% (Setting value: 600 to 1400)
ON	ON	Pr. 843: -400% to +400% (Setting value: 600 to 1400)

Tab. 6-18: Setting torque bias amount with the contact input

**NOTE**

Changing the terminal assignment using Pr. 178 to Pr. 189 "Input terminal function selection" may affect the other functions. Make setting after confirming the function of each terminal.

**Setting torque bias amount with terminal 1 (Pr. 840 = 1 or 2)**

- Calculate torque bias from the load input from terminal 1 as shown in the diagram below and provide torque bias.
- When torque bias amount is set from terminal 1, set "6" in Pr. 868 "Terminal 1 function assignment".

Pr. 840	Rise (Motor Forward Rotation)	Fall (Motor Reverse Rotation)
1	<p style="text-align: right;">1001513E</p>	<p style="text-align: right;">1001514E</p>
2	<p style="text-align: right;">1001515E</p>	<p style="text-align: right;">1001516E</p>

**Tab. 6-19:** Setting torque bias amount with terminal 1

**Example** ▽

Pr. 841 = 1025 for 25%  
 Pr. 842 = 975 for -25%  
 Pr. 843 = 925 for -75%





**Setting torque bias amount with terminal 1 (Pr. 840 = 3)**

- C16 "Terminal 1 bias command (torque/magnetic flux)", C17 "Terminal 1 bias (torque/magnetic flux)", C18 "Terminal 1 gain command (torque/magnetic flux)", C19 "Terminal 1 gain (torque/magnetic flux)", and Pr. 846 "Torque bias balance compensation" can be set automatically according to the load.
- When torque command is set from terminal 1, set "6" in Pr. 868 "Terminal 1 function assignment".
- Setting C16, C17 (Pr. 919) , C18, C19 (Pr. 920):

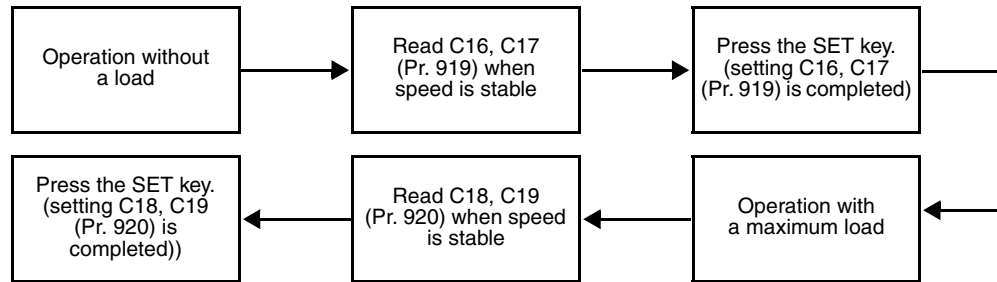

- Setting Pr. 846:

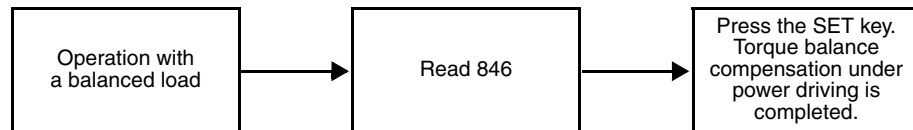
**NOTE**

When starting torque bias operation after completion of automatic setting, set "1 or 2" in Pr. 840.

**Torque bias operation**

- When a value other than 9999 is set in Pr. 844 "Torque bias filter", you can slow the rise of torque. At this time, the torque rises according to the time constant of the primary delay filter.
- Set the time for output torque be maintained with the torque bias command value alone in Pr. 845 "Torque bias operation time".

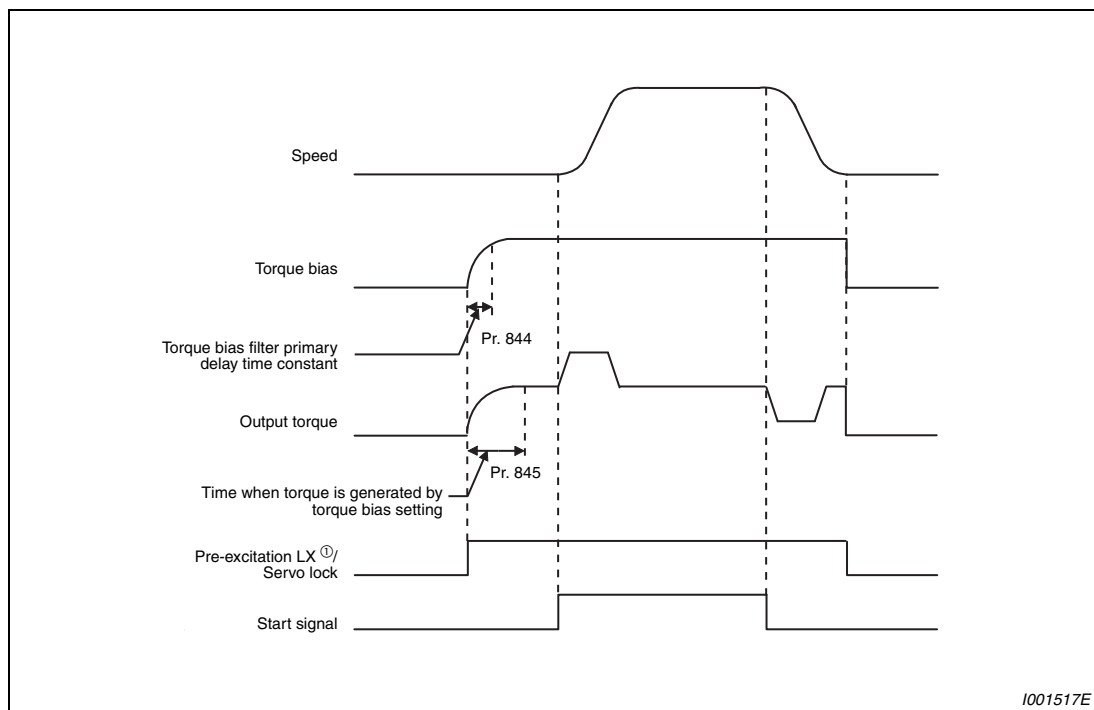
**Fig. 6-21: Torque output**

- ① When pre-excitation is not made, the torque bias functions simultaneously with the start signal.

**NOTES**

When torque bias is made valid and "6" is set in Pr. 868, terminal 1 serves as torque command not as frequency setting auxiliary. When override compensation is set by Pr. 73 and terminal 1 acts as main speed, no main speed (main speed = 0Hz) is selected.

Changing the terminal assignment using Pr. 178 to Pr. 189 "Input terminal function selection" may affect the other functions. Make setting after confirming the function of each terminal.

### 6.3.6 Prevent the motor from overrunning

(Pr. 285, Pr. 853, Pr. 873) Vector Sensorless Magnetic flux V/F

This function prevents the motor from overrunning when the load torque is too large and incorrect number of encoder is set.

Pr. No.	Name	Initial Value	Setting Range	Description	Parameters referred to	Refer to Section
<b>285</b>	Excessive speed deviation detection frequency <sup>①</sup>	9999	9999	Without speed deviation excessive	285	Overspeed detection frequency
			0–30Hz	If the difference (absolute value) between the speed command value and actual speed during speed control under vector control exceeds the Pr. 285 "Excessive speed deviation detection frequency" for more than the time set in Pr. 853 "Speed deviation time", speed deviation excessive occurs and inverter error (E.OSD) appears, resulting in a stop.		
<b>853</b>	Speed deviation time <sup>②</sup>	1.0s	0–100s			
<b>873</b>	Speed limit <sup>②</sup>	20Hz	0–120Hz	Frequency is limited at the set frequency + Pr. 873.		

① Acts as Overspeed detection frequency under encoder feed back operation.

② This parameter can be set when the FR-A7AP (option) is mounted.

#### Speed deviation excessive (Pr. 285, Pr. 853)

When the deviation between the set frequency and actual speed is large, e.g. too large load torque, this function can cause the inverter to provide a speed deviation excessive alarm (E.OSD) and come to an alarm stop.

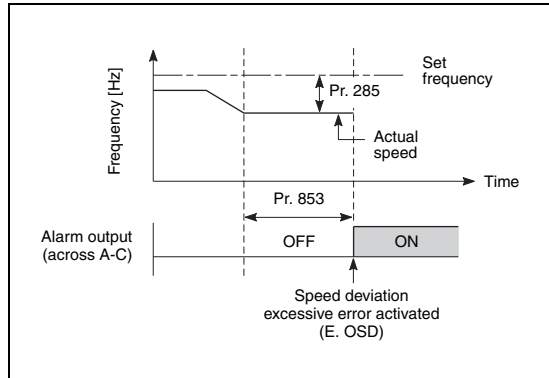
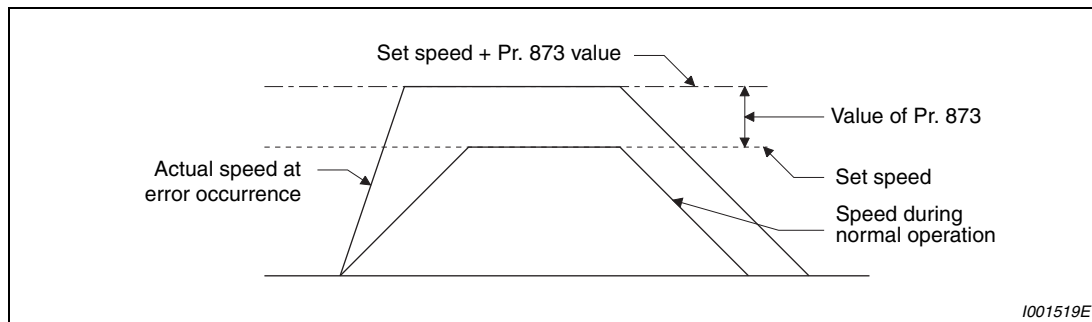

**Fig. 6-22:**  
Speed deviation excessive detection

1001518E

**Speed limit (Pr. 873)**

- This function prevents the motor from overrunning when the setting of number of encoder pulses and the actual number differ.  
When the setting of number of encoder pulses is smaller than the actual number, the motor may increase its speed. To prevent this, restrict the output frequency with frequency (obtained by adding the set frequency and Pr. 873 ).

**Fig. 6-23:** Speed limit**NOTES**

If automatic restart after instantaneous power failure (Pr. 57  $\neq$  9999) is selected when the setting of number of encoder pulses is smaller than the actual number, the output speed is limited with the synchronous speed obtained by adding the maximum setting (Pr. 1) and Pr. 873 setting.

When speed limit function is activated due to regenerative torque limit, output torque may suddenly decrease. In addition, output phase error (E.LF) may occur when speed limit function is activated during pre-excitation. When the setting of number of encoder pulses are correct, it is recommended to set a maximum value (120Hz) in Pr. 873.

### 6.3.7 Notch filter (Pr. 862, Pr. 863) Sensorless Vector

You can reduce the response level of speed control in the resonance frequency band of the mechanical system to avoid mechanical resonance.

Pr. No.	Name	Initial Value	Setting Range	Description	Parameters referred to	Refer to Section
<b>862</b>	Notch filter time constant	0	0–60	Refer to the following table	—	
<b>863</b>	Notch filter depth	0	0–3	0 (deep) → 3 (shallow)		

#### Notch filter time constant (Pr. 862)

- If you do not know the mechanical resonance frequency, decrease notch frequency gradually from the highest value. The point at which the smallest vibration is generated is the notch frequency setting.
- Machine characteristic can be obtained beforehand with machine analyzer by FR-Configurator. Necessary notch frequency can be determined from this.

Setting	0	1	2	3	4	5	6	7	8	9
Frequency	—	1000	500	333.3	250	200	166.7	142.9	125	111.1

Setting	10	11	12	13	14	15	16	17	18	19
Frequency	100	90.9	83.3	76.9	71.4	66.7	62.5	58.8	55.6	52.6

Setting	20	21	22	23	24	25	26	27	28	29
Frequency	50	47.6	45.5	43.5	41.7	40	38.5	37	35.7	34.5

Setting	30	31	32	33	34	35	36	37	38	39
Frequency	33.3	32.3	31.3	30.3	29.4	28.6	27.8	27.0	26.3	25.6

Setting	40	41	42	43	44	45	46	47	48	49
Frequency	25.0	24.4	23.8	23.3	22.7	22.2	21.7	21.3	20.8	20.4

Setting	50	51	52	53	54	55	56	57	58	59
Frequency	20.0	19.6	19.2	18.9	18.5	18.2	17.9	17.5	17.2	16.9

Setting	60
Frequency	16.7

#### Notch filter depth (Pr. 863)

Setting	3	2	1	0
Attenuation	4dB	8dB	14dB	40dB

## 6.4 Torque control by real sensorless vector control, vector control

Purpose	Parameter that must be Set		Refer to Section
Selection of torque command source and setting of torque command value	Torque command	Pr. 803–Pr. 806	6.4.4
Prevent the motor overspeed	Speed limit	Pr. 807–Pr. 809	6.4.5
Improve torque control accuracy	Gain adjustment for torque control	Pr. 824, Pr. 825, Pr. 834, Pr. 835	6.4.7
Stabilize the torque detection signal	Torque detection filter	Pr. 827, Pr. 837	6.6.1

### 6.4.1 Setting procedure of real sensorless vector control (torque control) Sensorless

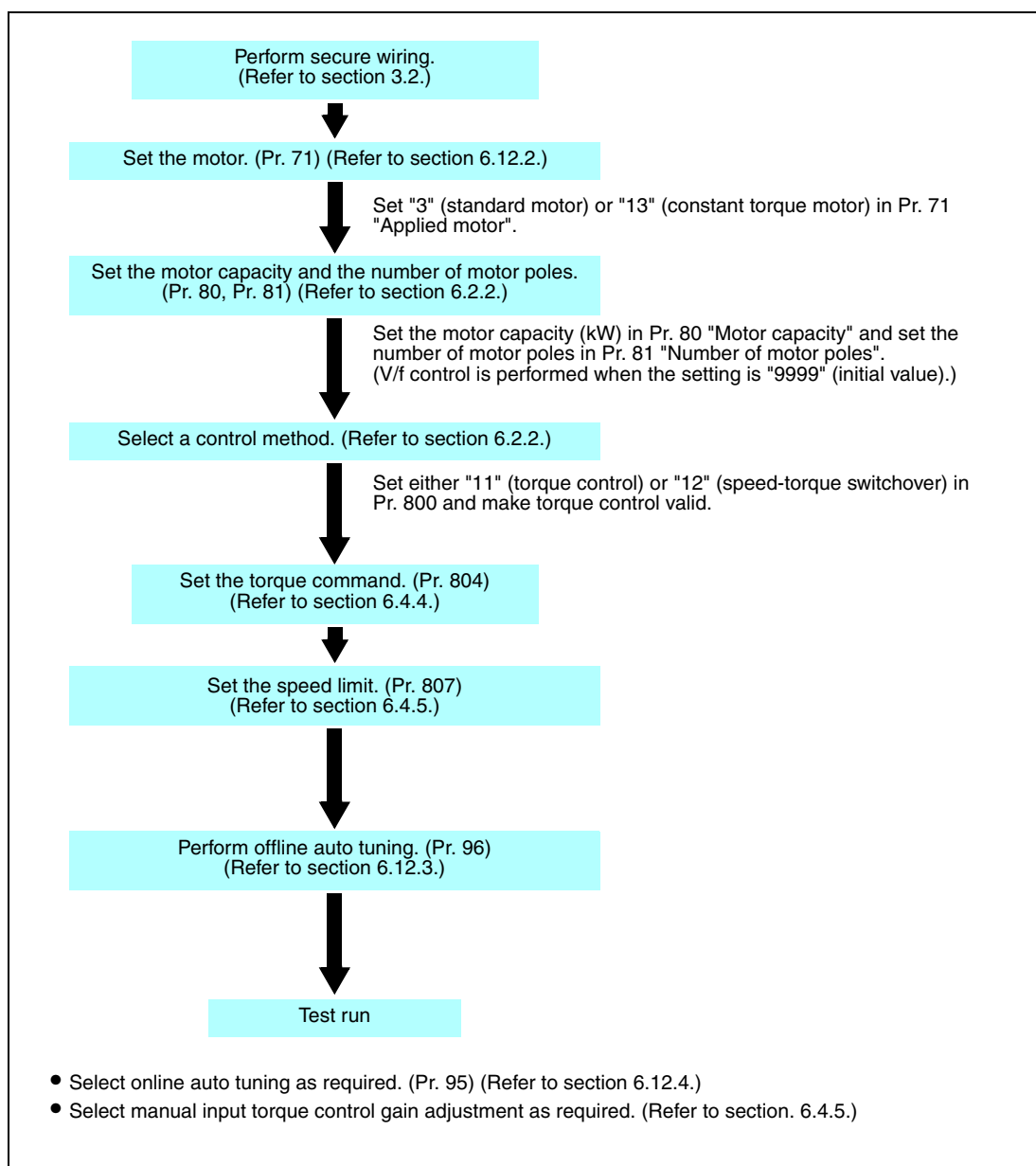

**Fig. 6-24:** Setting procedure of real sensorless vector control (torque control)

**NOTES**

Make sure to perform offline auto tuning before performing real sensorless vector control.

The carrier frequencies are selectable from among 2k, 6k, 10k, 14kHz for real sensorless vector control.

Torque control can not be performed in the low speed region and at a low speed with light load. Choose vector control.

Do not switch between the STF (forward rotation command) and STR (reverse rotation command) during operation under torque control. Overcurrent shut-off error (E.OC□) or opposite rotation deceleration error (E.11) occurs.

When the inverter is likely to start during motor coasting under real sensorless vector control, set to make frequency search of automatic restart after instantaneous power failure valid (Pr. 57 ≠ 9999, Pr. 162 = 10).

**CAUTION:**

- ***Performing pre-excitation (LX signal and X13 signal) under torque control may start the motor running at a low speed even when the start command (STF or STR) is not input. The motor may run also at a low speed when the speed limit value = 0 with a start command input. Perform pre-excitation after making sure that there will be no problem in safety if the motor runs.***
- ***For the 00023 to 00126, the speed deviation may become large at 20Hz or less and torque may become insufficient in the low speed region under 1Hz during continuous operation under real sensorless vector control. In such case, stop operation once and reaccelerate to improve the problems.***

## 6.4.2 Setting procedure of vector control (torque control) Vector

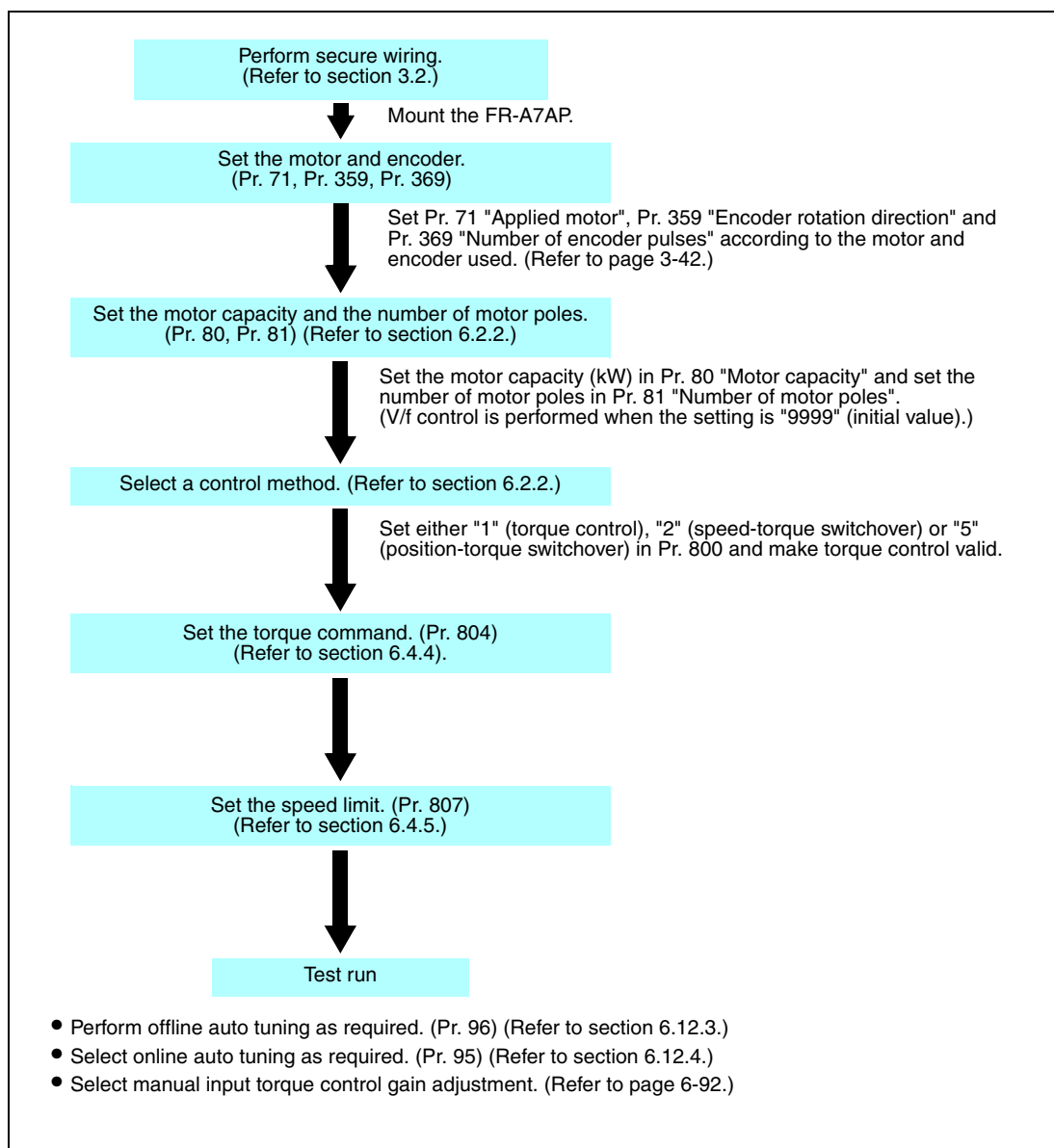

**Fig. 6-25:** Setting procedure of vector control (torque control)



### 6.4.3 Torque control

- Torque control is exercised to develop torque as set in the torque command.
- The motor speed becomes constant when the motor output torque and load torque are balanced. For torque control, therefore, the speed is determined by the load.
- For torque control, the motor gains speed as the motor output torque becomes greater than the motor load. To prevent overspeed, set the speed limit value so that the motor speed does not increase too high. (Torque control is disabled under speed limit since speed control is exercised.)
- When speed limit is not set, the speed limit value setting is regarded as 0Hz to disable torque control.

### 6.4.4 Torque command (Pr. 803 to Pr. 806) Sensorless Vector

Torque command source for torque control can be selected.

Pr. No.	Name	Initial Value	Setting Range	Description	Parameters referred to	Refer to Section	
<b>803</b>	Constant power range torque characteristic selection	0	0	Constant motor output limit	868 Terminal 1 function assignment C16–C19 Terminal 1 bias, gain torque	6.3.2 6.20.6	
			1	Constant torque limit			
<b>804</b>	Torque command source selection	0	0	Torque command by terminal 1 analog input (Refer to section 6.20.6.)			
			1	Torque command by parameter setting (Pr. 805 or Pr. 806) (–400% to +400%)			
			3	Torque command by parameter setting (Pr. 805 or Pr. 806) (–400% to +400%)			Torque command with using CC-Link communication (FR-A7NC) Setting from the remote resistor can be made. (–400% to +400%)
			4	12 bit/16 bit digital input (FR-A7AX)			
			5	Torque command by parameter setting (Pr. 805 or Pr. 806) (–400% to +400%)			Torque command with using CC-Link communication (FR-A7NC) Setting from the remote resistor can be made. (–327.68% to +327.67%)
6		Torque command with using CC-Link communication (FR-A7NC) (–327.68% to +327.67%)					
<b>805</b>	Torque command value (RAM)	1000%	600–1400%	Writes the torque command value to the RAM. On the assumption that 1000% is 0%, the torque command is set by an offset from 1000%.			
<b>806</b>	Torque command value (RAM, EEPROM)	1000%	600–1400%	Writes the torque command value to the RAM and EEPROM. On the assumption that 1000% is 0%, the torque command is set by an offset from 1000%.			

**Control block diagram**

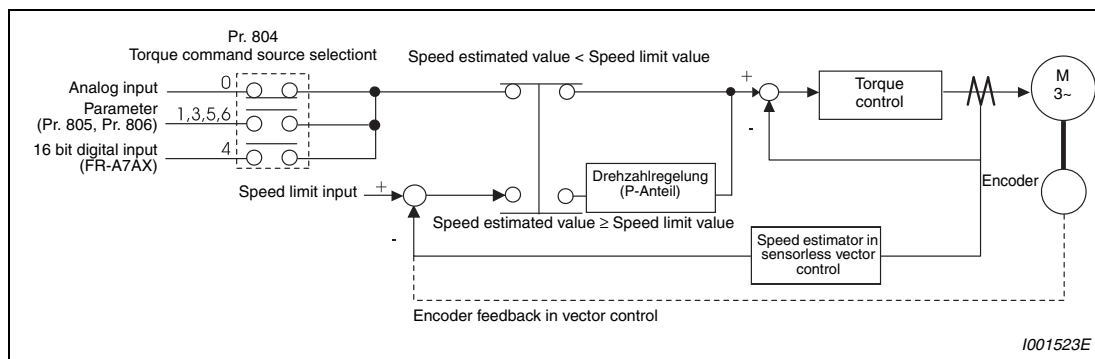

**Fig. 6-26: Block diagram**

**Torque command (Pr. 804 = 0 (initial value)) by analog input (terminal 1)**

- Torque command is given by voltage (current) input to terminal 1.
- When torque command is input from terminal 1, set "4 or 3" in Pr. 868 "Terminal 1 function assignment".
- Torque command by analog input can be calibrated using calibration parameter C16 (Pr. 919) to C19 (Pr. 920). (Refer to section 6.20.6.)

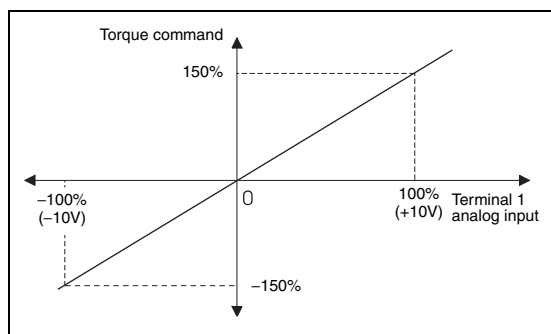
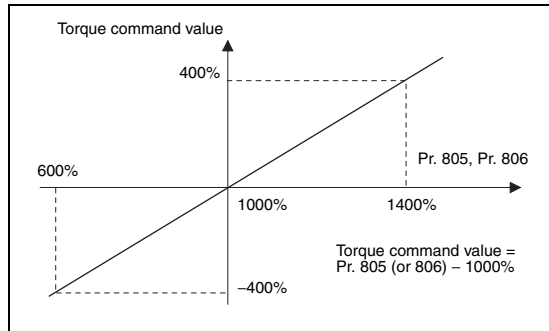

**Fig. 6-27: Torque command by terminal 1**

I001524E

**Torque command using parameters (Pr. 804 = 1)**

- Torque command value can be set by setting Pr. 805 "Torque command value (RAM)" or Pr. 806 "Torque command" value (RAM, EEPROM)".
- For Pr. 805 or Pr. 806, the torque command is set by an offset from 1000% on the assumption that 1000% is 0%. The relationship between the Pr. 805 or Pr. 806 setting and actual torque command value at this time is shown on the left.
- When changing the torque command frequently, write to Pr. 805. Performing frequent parameter write to Pr. 806 will shorten the life of the EEPROM.



**Fig. 6-28:**  
Torque command using parameters

1001525E

**NOTE**

When torque command is set in Pr. 805 (RAM), powering off the inverter will erase the changed parameter values. Therefore, the parameter value available when power is switched on again is the value set in Pr. 806 (EEPROM).

**CAUTION:**

*When giving a torque command by parameter setting, set the speed limit value to an appropriate value to prevent overspeed.*

**Torque command by CC-Link communication (Pr. 804 = 3, 5, 6)**

- Writing a value to Pr. 805 or Pr. 806 using the FR-A7NC (communication option) sets the torque command value.
- When "3 or 5" is set in Pr.804, torque command can be set in remote register RWw1 or RWwC using the FR-A7NC (communication option).
- By setting "5, 6" in Pr.804, the range of torque command setting from FR-A7NC (communication option) is set from -327.68% to 327.67% (0.01% increments).

Pr. 804	Torque Command Source	Setting Range	Increments
1	Torque command by parameter setting (Pr. 805 or Pr. 806)	600 to 1400 (-400% to 400%)	1%
3	Torque command by parameter setting (Pr. 805 or Pr. 806)	600 to 1400 (-400% to 400%)	1%
	Torque command from remote register (RWw1 or RWwC) with using CC-Link communication (FR-A7NC)		
5	Torque command by parameter setting (Pr. 805 or Pr. 806)	600 to 1400 (-400% to 400%)	1%
	Torque command from remote register (RWw1 or RWwC) with using CC-Link communication (FR-A7NC)		
6	Torque command by parameter setting (Pr. 805 or Pr. 806) without using CC-Link communication (FR-A7NC)	600 to 1400 (-400% to 400%)	1%
	Torque command by parameter setting (Pr. 805 or Pr. 806) with using CC-Link communication (FR-A7NC)		

**Tab. 6-20:** Torque command by CC-Link communication**NOTE**

For details of the setting with the FR-A7NC, refer to the FR-A7NC instruction manual.

**Torque command by 16 bit digital input (Pr. 804 = 4)**

Give a torque command by 16 bit or 12 bit digital input using the FR-A7AX (plug-in option).

**NOTE**

For details of the setting with the FR-A7AX, refer to the FR-A7AX instruction manual.

**Change the torque characteristics in the constant power (Pr. 803)**

Due to the motor characteristics, torque is reduced at or above the base frequency. Set "1" in Pr. 803 "Constant power range torque characteristic selection" when you want to limit the torque to be constant even at or above the base frequency.

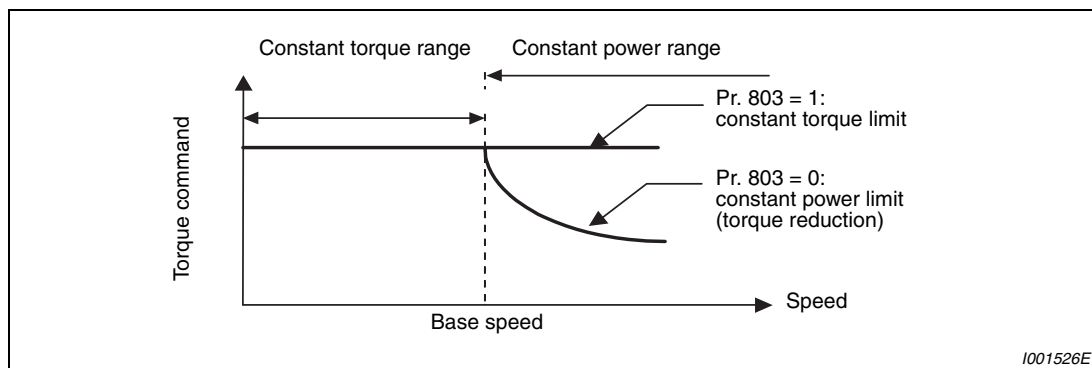
**Fig. 6-29:** Motor characteristic

**6.4.5 Speed limit (Pr. 807 to Pr. 809)** Sensorless Vector

Set the speed limit value to prevent overspeed of the motor in case the load torque becomes less than the torque command value, etc. during torque control operation.

Pr. No.	Name	Initial Value	Setting Range	Description	Parameters referred to	Refer to Section
<b>807</b>	Speed limit selection	0	0	Use the speed command value during speed control as speed limit.	1 Maximum frequency, 2 Minimum frequency 7 Acceleration time 8 Deceleration time 13 Starting frequency 4-6 Multi-speed operation 24-27 232-239 868 125 Terminal 1 function assignment 126 Frequency setting voltage (current) bias/gain C2-C7 C12-C15	6.8.1 6.8.1 6.11.1 6.11.1 6.11.2 6.10.1 6.3.2 6.20.5
			1	According to Pr. 808 and Pr. 809, set the speed limit in forward and reverse rotation directions individually.		
			2	Forward/reverse rotation speed limit The analog voltage of the terminal 1 input is used to make speed limit. The speed limit of the forward rotation and reverse rotation is switched according to the polarity.		
<b>808</b>	Forward rotation speed limit	50Hz	0-120Hz	Set the speed limit for the forward rotation direction.		
<b>809</b>	Reverse rotation speed limit	9999	0-120Hz	Set the speed limit of the reverse rotation side.		
			9999	As set in Pr. 808.		

**Control block diagram**

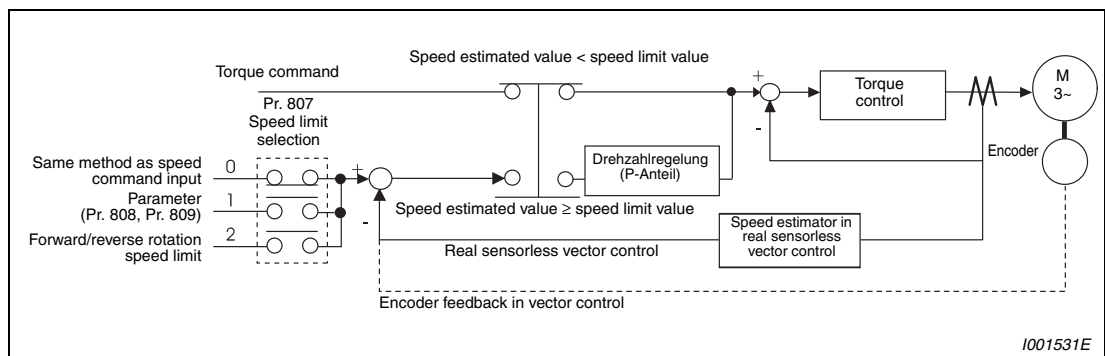

**Fig. 6-30: Control block diagram**

**Use the speed command for speed control (Pr. 807 = 0, initial value)**

- Set the speed limit in the same method as speed setting for speed control (speed setting by the PU (FR-DU07/FR-PU07/FR-PU04), multi-speed setting, options, etc.)
- According to the acceleration time set in Pr. 7 "Acceleration time", the limit level is increased from 0Hz upon turning on of the start signal, and when the start signal turns off, the speed limit level is decreased from the then speed limit level to the DC injection brake operation speed in Pr. 10 to a stop in accordance with the deceleration time set in Pr. 8 "Deceleration time".

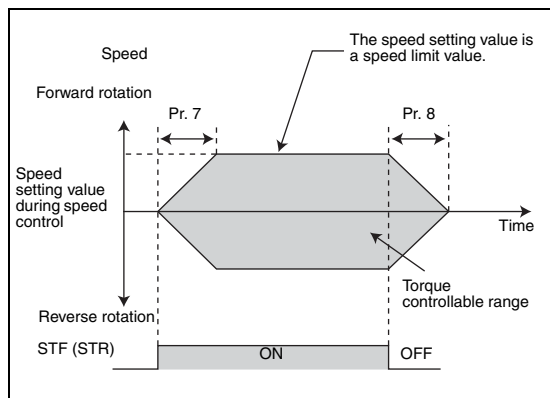
**Fig. 6-31:**

Use the speed command for speed control

1001532E

**NOTES**

When the above speed limit command is greater than the Pr. 1 "Maximum frequency" value, the speed limit value is the Pr. 1 "Maximum frequency" value, and when the speed limit command is less than the Pr. 2 "Minimum frequency" value, the speed limit value is the Pr. 2 "Minimum frequency" value. Similarly when the speed limit command is smaller than Pr. 13 "Starting frequency", the speed limit value is 0Hz.

When speed limit is to be made using analog input, perform calibration of the analog input terminal 1, 2 and 4. (Refer to section 6.20.6.)

**CAUTION:**

**When speed limit is to be made using the analog command (terminal 1, 2, 4), turn off the external signals (RH, RM, RL). If any of external signals (RH, RM, RL) is on, multi-speed limits are made valid.**

**Set the forward rotation and reverse rotation individually (Pr. 807 = 1)**

Set the speed limit during forward rotation using Pr. 808 "Forward rotation speed limit" and the speed limit during reverse rotation using Pr. 809 "Reverse rotation speed limit". The speed during forward and reverse rotation is limited at the setting value of Pr. 808 when "9999" (initial value) is set in Pr. 809.

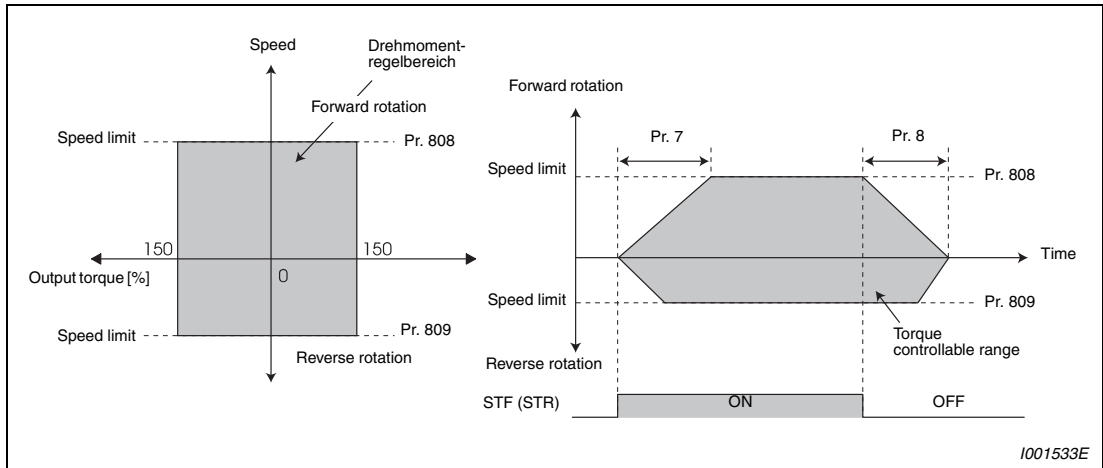

**Fig. 6-32:** Set the forward rotation and reverse rotation individually

**Forward rotation/reverse rotation speed limit (Pr. 807 = 2)**

- When making a speed limit using analog input from terminal 1, the speed limit of the forward and reverse rotation can be switched according to the polarity of voltage.
- Forward/reverse rotation speed limit is made valid when Pr. 868 "Terminal 1 function assignment" = 5.
- For 0 to 10V input, set the forward rotation speed limit. The reverse rotation speed limit at this time is the value of Pr. 1 "Maximum frequency".
- For -10 to 0V input, set the reverse rotation speed limit. The forward rotation speed limit at this time is the value of Pr. 1 "Maximum frequency".
- The maximum speed of both the forward and reverse rotations is Pr. 1 "Maximum frequency".

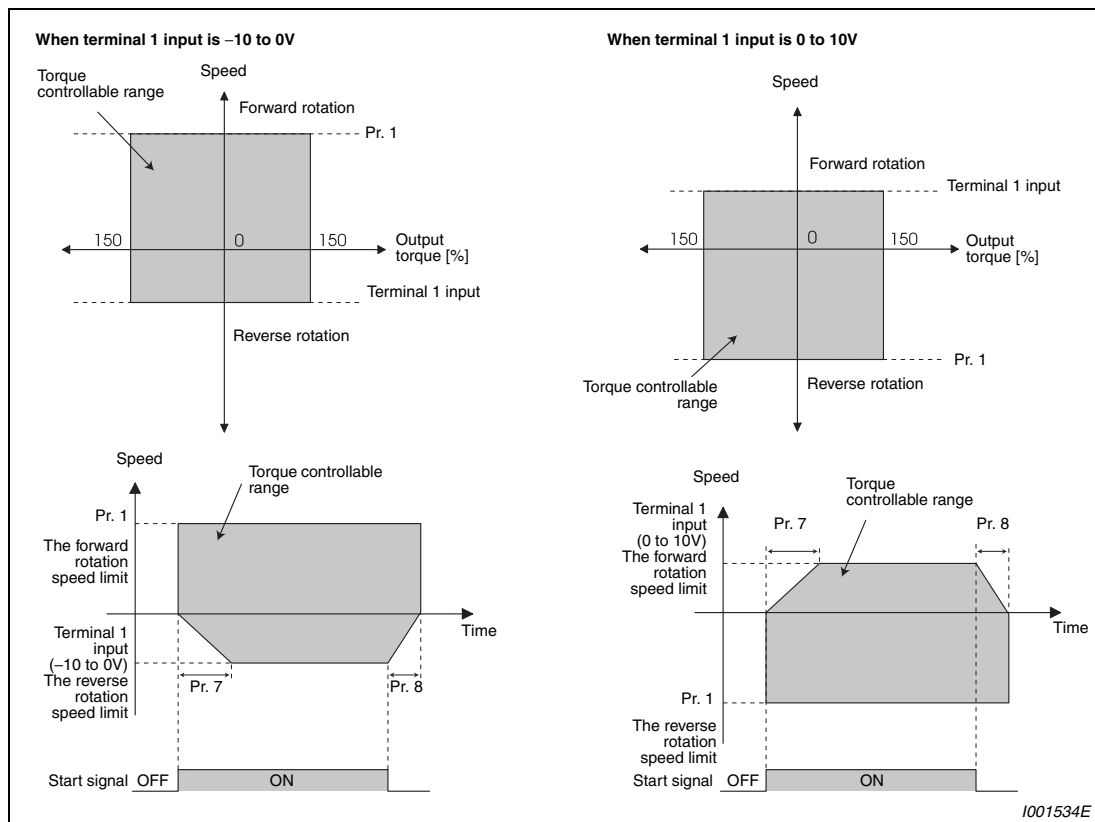

**Fig. 6-33:** Forward rotation/reverse rotation speed limit

**NOTE**

When making speed limit from terminal 1, make calibration of terminal 1. (Refer to section 6.20.6).

**CAUTION:**

When the actual speed reaches or exceeds the speed limit value, torque control is switched to speed control to prevent overspeed. "SL" appears on the operation panel during speed limit operation and the OL signal is output. (Refer to section 6.4.6.)



### 6.4.6 Activation of torque control during start and stop processes

The inverter does not immediately reach the torque command value when the start signal is turned on. Motor torque is built up during the transition time by increasing the speed with the acceleration time set in parameter 7 as shown in Fig. 6-34.

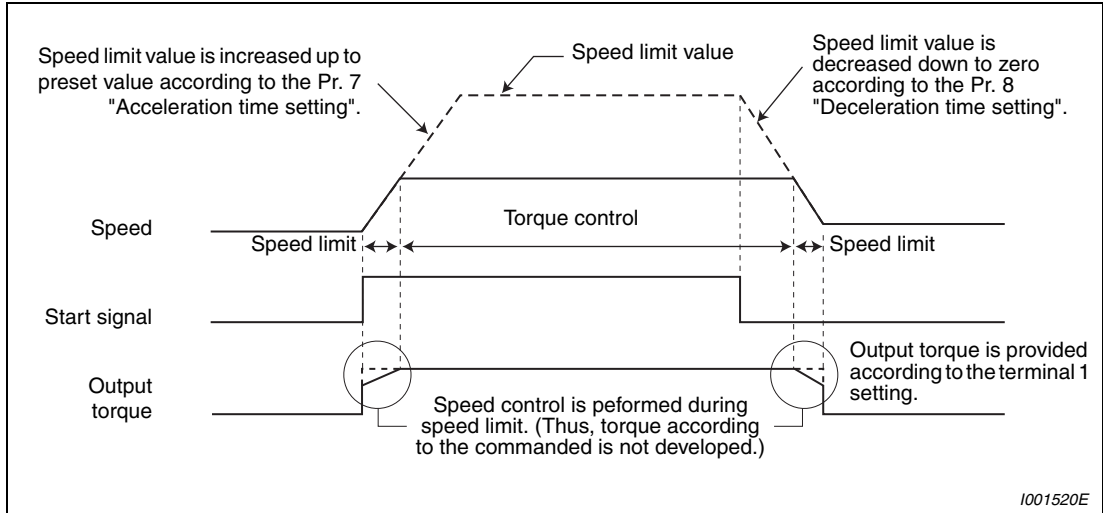

Fig. 6-34: Transition operation

When "0" is set in Pr. 7 or Pr. 8 , speed control is exercised upon powering off a start signal and the output torque is limited at the torque limit value.

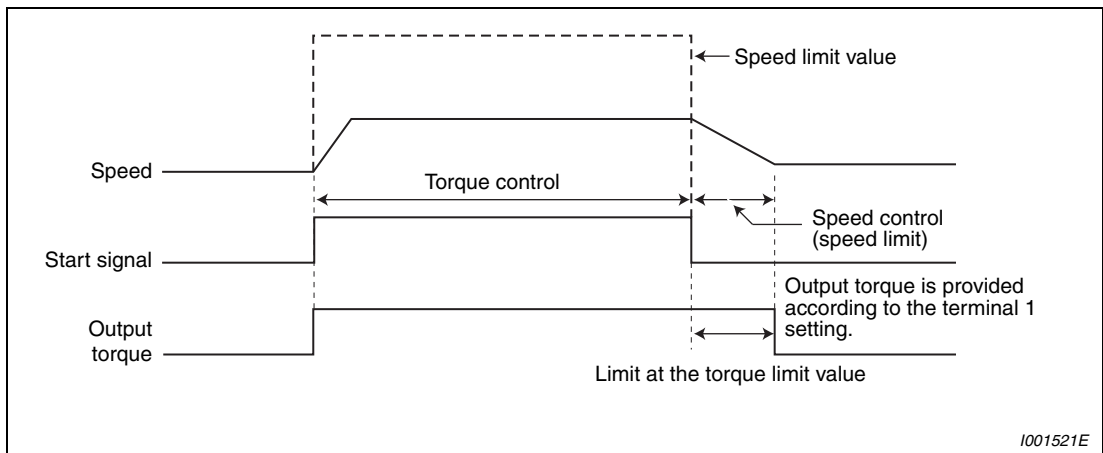

Fig. 6-35: Transition operation

Signal	Description	
Start signal	External operation	STF-, STR signal
	PU operation	FWD and REV key of FR-DU07, FR-PU07 or FR-PU04
Torque command	Select the input method of torque command and input the torque command.	
Speed limit	Select the input method of speed limit and input the speed limit value.	

Tab. 6-21: Signal input

**Operation example (when Pr. 804 = 0)**

Torque control is enabled if the actual speed is less than the speed limit value. When the actual speed reaches or exceeds the speed limit value, speed limit operation starts, torque control is stopped, and speed control (proportional control) starts.

The following shows the operations in response to the analog input command from terminal 1.

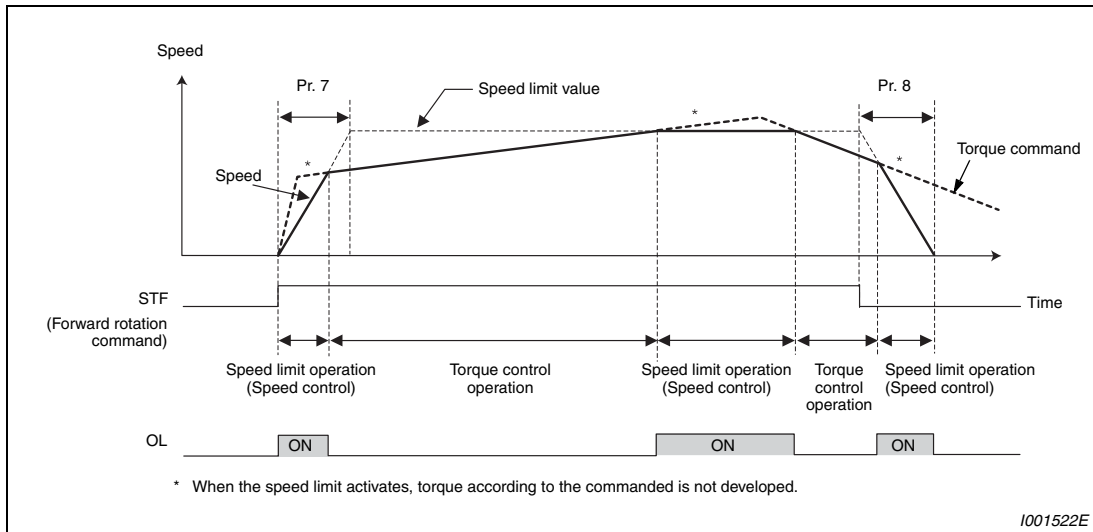

**Fig. 6-36: Transition operation**

- 1)When STF signal is turned on, the speed limit value is increased according to the time set in Pr. 7.
- 2)Speed control operation is performed if the actual speed rises to or above the speed limit value. OL signal is output during speed limit.
- 3)When the STF signal is turned off, the speed limit value is decreased according to the time set in Pr. 8.
- 4)For torque control, the actual speed becomes constant when the torque command and load torque are balanced.
- 5)The motor torque developing direction is determined by the combination of the torque command input polarity and start signal as indicated in the following table.

Torque Command Polarity	Torque Developing Direction	
	STF signal ON	STR signal ON
Positive	Forward rotation direction (forward rotation driving/reverse rotation regeneration)	Reverse rotation direction (forward rotation regeneration/reverse rotation driving)
Negative	Reverse rotation direction (forward rotation regeneration/reverse rotation driving)	Forward rotation direction (forward rotation driving/reverse rotation regeneration)

**Tab. 6-22: Motor torque developing direction**

**NOTES**

When speed limit operation starts, speed control is exercised to enable internal torque limit (Pr. 22 "Torque limit level") (initial value). Speed control may not be returned to torque control in this case. Torque limit be set to external torque limit (terminal 1, 4)

Undervoltage avoidance function (Pr. 261 = 11, 12) of power-failure deceleration stop function is made invalid under torque control. When Pr. 261 = 11 (12), the inverter operates in the same manner as when 1 (2) is set in Pr. 261.

Set linear acceleration/deceleration (Pr. 29 = 0 (initial value)) when torque control is exercised. When acceleration/deceleration patterns other than the linear acceleration/deceleration are selected, the protective function of the inverter may function. (Refer to section 6.11.3).

**CAUTION:**

*Performing pre-excitation (LX signal and X13 signal) under torque control (real sensorless vector control or vector control) may start the motor running at a low speed even when the start command (STF or STR) is not input. The motor may run also at a low speed when the speed limit value = 0 with a start command input. Perform pre-excitation after making sure that there will be no problem in safety if the motor runs.*

## 6.4.7 Gain adjustment of torque control

(Pr. 824, Pr. 825, Pr. 834, Pr. 835) Sensorless Vector

Although stable operation is possible with the initial value, make adjustment when any of such phenomena as unusual motor and machine vibration/noise and overcurrent has occurred.

Pr. No.	Name	Initial Value	Setting Range	Description	Parameters referred to	Refer to Section
<b>824</b>	Torque control P gain 1	100%	0–200%	Set the current loop proportional gain. 100% is equivalent to 2000rad/s.	72 PWM frequency selection	6.19.1
<b>825</b>	Torque control integral time 1	5ms	0–500ms	Set the current loop integral compensation time.	178–189 Input terminal function selection)	6.14.1
<b>834</b>	Torque control P gain 2	9999	0–200%	Set the current loop proportional gain when the RT signal is on.	800 Control method selection	6.2.2
			9999	Without torque control P gain 2 function	807 Speed limit selection	6.4.5
<b>835</b>	Torque control integral time 2	9999	0–500ms	Set the current loop integral compensation time when the RT signal is on.	C16–C19 Torque setting voltage (current) bias and gain	6.20.6
			9999	Without torque control integral time 2 function		

### Adjustment of current loop proportional (P) gain

- For general adjustment, make setting within the range 50 to 200% as a guideline.
- Increasing the value improves trackability in response to a current command change and reduces current variation with disturbance. However, a too large gain will cause instability, generating harmonic torque pulsation.

### Adjustment of current control integral time

- A small value enhances the torque response level, but a too small value will cause current fluctuation.
- Decreasing the value shortens the time taken to return to the original torque if current variation with disturbance occurs.

### Use multiple gains

- When you want to change the gain according to applications, switch multiple motors with one inverter, etc., use "Torque control P gain 2" and "Torque control integral time 2".
- Pr. 834 "Torque control P gain 2" and Pr. 835 "Torque control integral time 2" are valid when the RT signal is on.

### NOTES

The RT signal acts as the second function selection signal and makes the other second functions valid. (Refer to section 6.14.3.)

The RT signal is assigned to the terminal RT in the initial setting. By setting "3" in any of Pr. 178 to Pr. 189 "Input terminal function selection", you can assign the RT signal to the other terminal.

### Adjustment procedure

Make adjustment when any of such phenomena as unusual motor and machine vibration/noise/ current and overcurrent has occurred.

- ① Check the conditions and simultaneously change the Pr. 824 value.
- ② If you cannot make proper adjustment, change the Pr. 825 value and repeat step ①.

Adjustment Method	
Set Pr. 824 a little lower and Pr. 825 a little higher. First lower Pr. 824 and check the motor for unusual vibration/ noise and overcurrent. If the problem still persists, increase Pr. 825.	
Pr. 824	Decrease the value 10% by 10% until just before unusual noise and current are improved, and set about 0.8 to 0.9 of that value. Note that a too low value will produce current ripples, causing the motor to generate sound synchronizing the cycle of current ripples.
Pr. 825	Increase the current value double by double until just before an unusual noise and current does not occur, and set about 0.8 to 0.9 of that value. Note that taking a too long time will produce current ripples, causing the motor to generate sound synchronizing the cycle of current ripples.

**Tab. 6-23:** Adjustment method for setting parameter 824 and 825

### Troubleshooting (Torque)

	Phenomenon	Cause	Countermeasures
1	Torque control is not exercised normally.	(1) The phase sequence of the motor or encoder wiring is wrong. (2) The Pr. 800 "Control method selection" setting is improper. (3) The speed limit value is not input. (4) The torque command varies. (5) The torque command does not match the inverter-recognized value. (6) Torque variation due to the change in the motor temperature.	(1) Check the wiring. (Refer to section 3.2.) (2) Check the Pr. 800 setting. (Refer to section 6.2.2.) (3) Set the speed limit value. (If the speed limit value is not input, the motor will not rotate since the speed limit value is regarded as 0Hz.) (4)-1 Check that the command device gives a correct torque command. (4)-2 Decrease Pr. 72 "PWM frequency selection". (4)-3 Increase Pr. 826 "Torque setting filter 1". (5) Recalibrate C16 "Terminal 1 bias command (torque/magnetic flux)", C17 "Terminal 1 bias (torque/magnetic flux)", C18 "Terminal 1 gain command (torque/magnetic flux)", C19 "Terminal 1 gain (torque/magnetic flux)". (Refer to section 6.20.6.) (6) Select magnetic flux observer by setting Pr. 95 "Online auto tuning selection". (Refer to section 6.12.4.)

**Tab. 6-23:** Troubleshooting during torque control (1)

	Phenomenon	Cause	Countermeasures
2	When the torque command is small, the motor rotates in the direction opposite to the start signal.	The offset calibration of the torque command does not match.	Recalibrate C16 "Terminal 1 bias command (torque/magnetic flux)" and C17 "Terminal 1 bias (torque/magnetic flux)". (Refer to section 6.20.6).
3	Normal torque control cannot be exercised during acceleration/deceleration. The motor vibrates.	The speed limit is activated. (When Pr. 807 = 0 or 2, the speed limit may be activated since the speed limit value changes with the setting of the acceleration/deceleration time in Pr. 7 and Pr. 8. )	Reduce the acceleration/deceleration time. Or, set the acceleration/deceleration time to "0". (The speed limit during acceleration/deceleration depends on the speed limit during the constant speed.)
4	Output torque is not linear in response to the torque command.	Insufficient torque.	Return the excitation ratio in Pr. 854 to the initial value.

**Tab. 6-23:** Troubleshooting during torque control (2)

## 6.5 Position control by vector control

This position control function allows precise movements to pre-selected positions. A cascaded control loop consisting of a position controller and a subordinated speed controller guarantee high-precision positioning.

The control loop can be optimised by changing the control parameters if required.

Purpose	Parameter that must be Set		Refer to Section
Conditional position control by parameter setting	Position command by parameter	Pr. 419, Pr. 464–Pr. 494	6.5.2
Position control by pulse train input of the inverter	Position command by conditional pulse train	Pr. 419, Pr. 428–Pr. 430	6.5.3
Adjust the gear ratio of motor and machine	Setting the electronic gear	Pr. 420, Pr. 421, Pr. 424	6.5.4
Setting of positioning adjustment parameter	In-position width Excessive level error	Pr. 426, Pr. 427	6.5.5
Improve position control accuracy	Gain adjustment of position control	Pr. 422, Pr. 423, Pr. 425	6.5.6

### 6.5.1 Position control

- In the position control, the speed command is calculated so that the difference between command pulse (or parameter setting) and the number of feedback pulses from the encoder is zero to run the motor.
- This inverter can perform conditional position feed by contact input and position control by inverter conditional pulse input.

**Setting procedure**

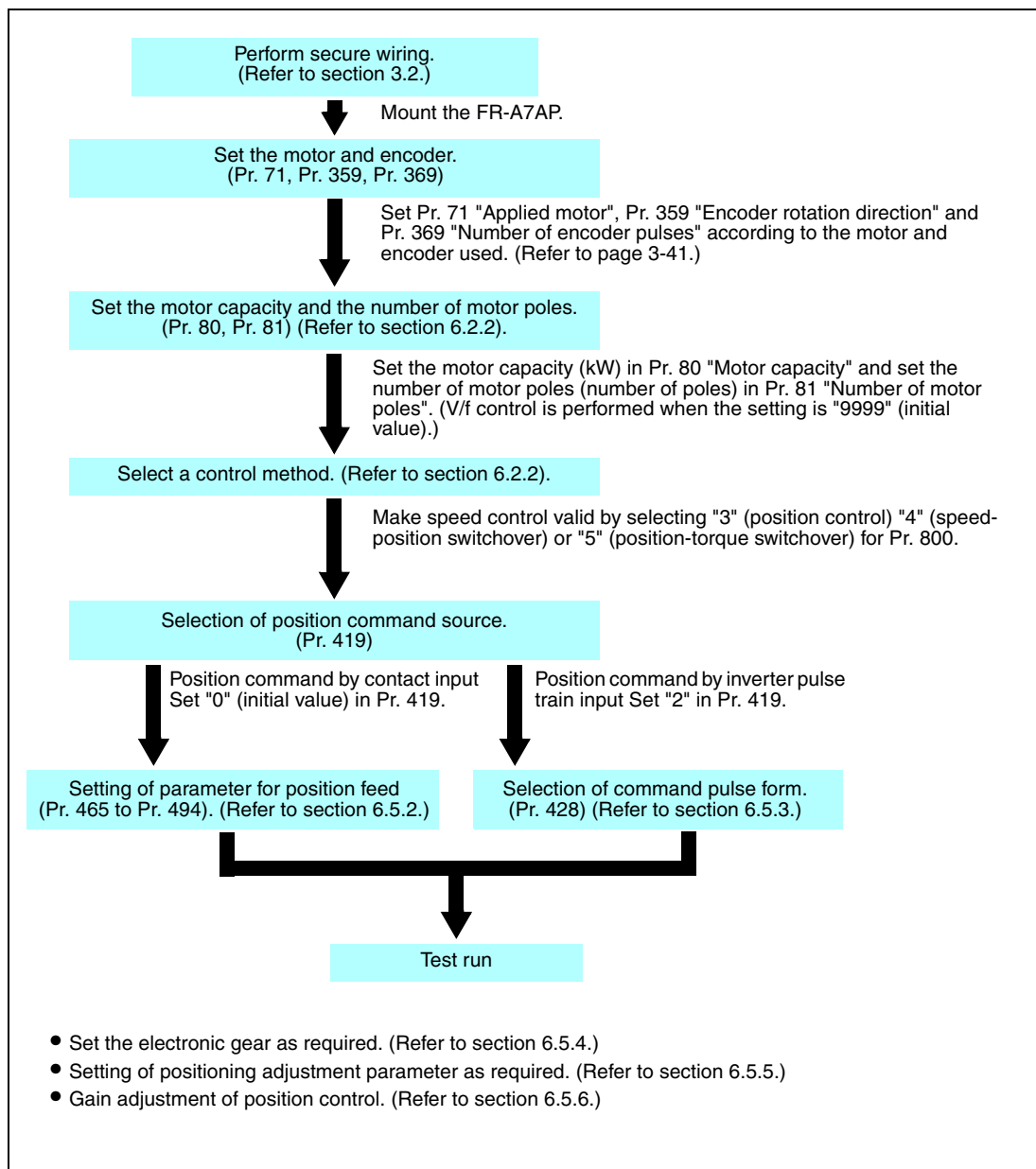

**Fig. 6-37:** Selection of position control



## Control block diagram

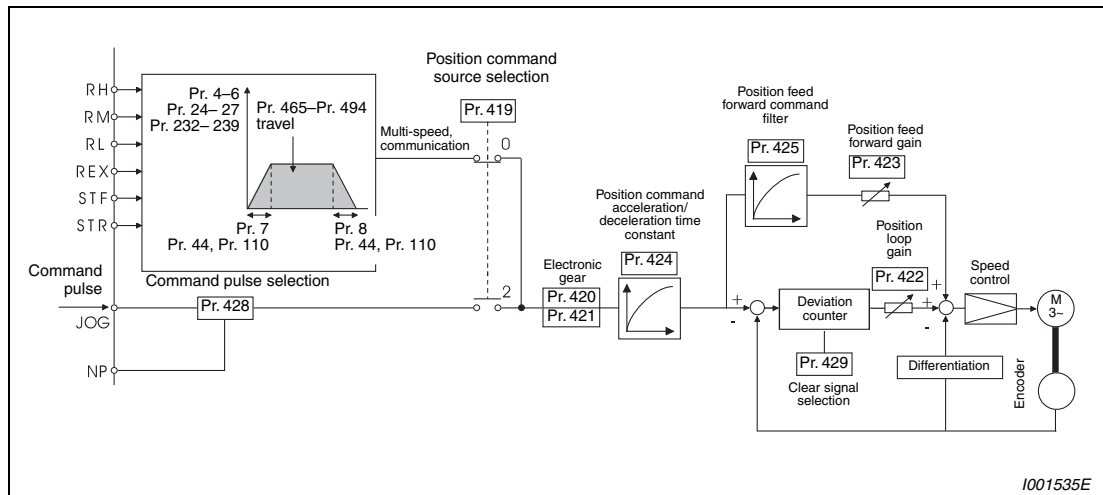
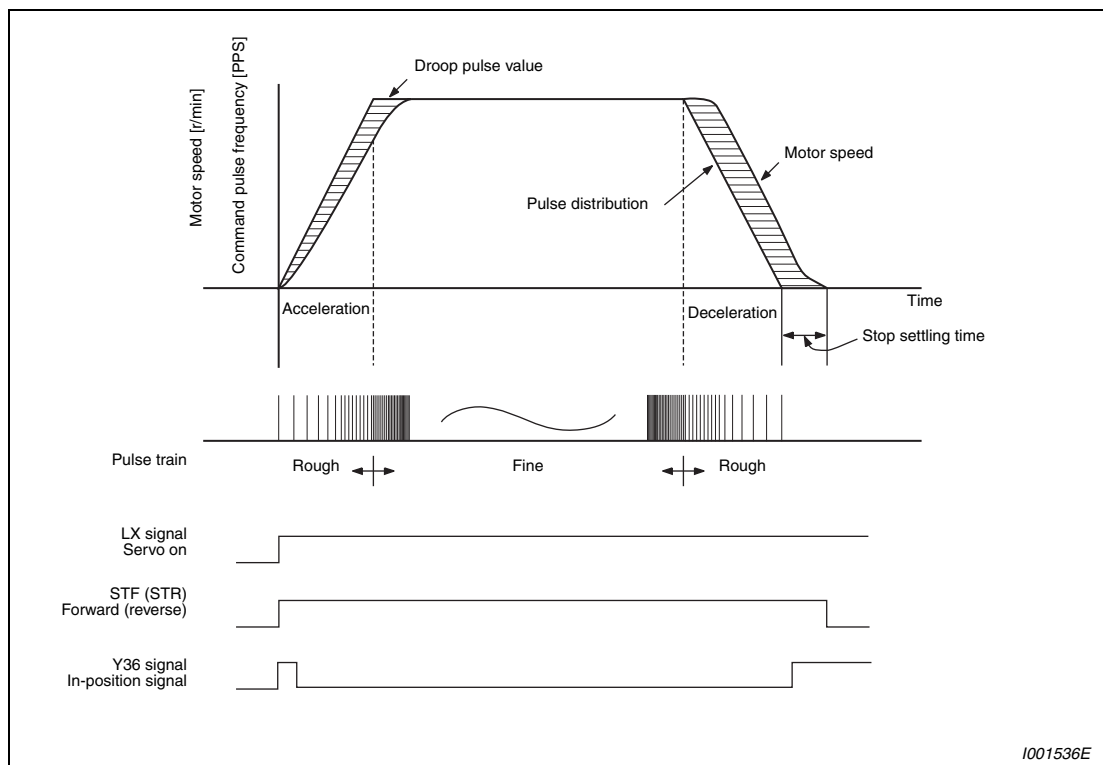

Fig. 6-38: Control block diagram

## Example of operation

The speed command given to rotate the motor is calculated to zero the difference between the number of internal command pulse train pulses (when Pr. 419 = 0, the number of pulses set by parameter (Pr. 465 to Pr. 494) is changed to the command pulses in the inverter) and the number of pulses fed back from the motor end encoder.

- When a pulse train is input, pulses are accumulated in the deviation counter and these droop pulses act as position control pulses to give the speed command.
- As soon as the motor starts running under the speed command of the inverter, the encoder generates feed back pulses and the droop of the deviation counter is counted down. The deviation counter maintains a given droop pulse value to keep the motor running.
- When the command pulse input stops, the droop pulses of the deviation counter decrease, reducing the speed. The motor stops when there are no droop pulses.
- When the number of droop pulses has fallen below the value set in Pr. 426 "In-position width", it is regarded as completion of positioning and the in-position signal (Y36) turns on.



**Fig. 6-39: Positioning**

- For conditional position control function by contact input, the STF and STR terminals provide the forward (reverse) command signal. The motor can run only in the direction where the forward (reverse) signal is on. Turning the STF signal off does not run the motor forward and turning the STR signal off does not run the motor reverse.
- The pulse train is rough during acceleration and coarse at the maximum speed. During deceleration the pulse train is rough and at last there are no pulses. The motor stops shortly after the command pulses stop. This time lag is necessary for maintaining the stop accuracy and called stop settling time.

#### NOTES

For the servo on signal (LX), set "23" in Pr. 178 to Pr. 189 "Input terminal function selection" to assign the function.

For the in-position signal (Y36), set "36" in Pr. 190 to Pr. 196 "Output terminal function selection" to assign the function.

Changing the terminal function using any of Pr. 178 to Pr. 189, 190 to Pr. 196 may affect the other functions. Make setting after confirming the function of each terminal.

## 6.5.2 Conditional position feed function by contact input (Pr. 419, Pr. 464 to Pr. 494)

Inputting the number of pulses (positions) in the parameters and setting multi-speed (refer to page 6-132) and forward (reverse) commands enable position control. The motor does not return to the home position with this conditional position feed function.

Pr. No.	Name	Initial Value	Setting Range	Description	Parameters referred to	Refer to Section
<b>419</b>	Position command source selection	0	0	Conditional position control function by contact input. (position command by parameter settings)	20 Acceleration/deceleration reference frequency	6.11.1
			2	Conditional pulse train position command by inverter pulse train input	29 Acceleration/deceleration pattern selection	6.11.3
<b>464</b>	Digital position control sudden stop deceleration time	0 s	0–360,0 s	Set the time until the inverter stops when the forward rotation (reverse rotation) command is turned off with the position feed forward function.		

Pr. No.	Name	Initial Value	Setting Range	Selection Method (OFF: —, ON: ✓)				Position feed frequency	Parameters referred to	Refer to Section
				REX	RH	RM	RL			
465	First position feed amount lower 4 digits)	0	0–9999	—	✓	—	—	High speed (Pr. 4)	20 Acceleration/deceleration reference frequency 29 Acceleration/deceleration pattern selection	6.11.1 6.11.3
466	First position feed amount upper 4 digits	0	0–9999	—	—	—	—			
467	Second position feed amount lower 4 digits	0	0–9999	—	—	✓	—	Middle speed (Pr. 5)		
468	Second position feed amount upper 4 digits	0	0–9999	—	—	—	—			
469	Third position feed amount lower 4 digits	0	0–9999	—	—	—	✓	Low speed (Pr. 6)		
470	Third position feed amount upper 4 digits	0	0–9999	—	—	—	—			
471	Fourth position feed amount lower 4 digits	0	0–9999	—	—	✓	✓	4. speed (Pr. 24)		
472	Fourth position feed amount upper 4 digits	0	0–9999	—	—	—	—			
473	Fifth position feed amount lower 4 digits	0	0–9999	—	✓	—	✓	5. speed (Pr. 25)		
474	Fifth position feed amount upper 4 digits	0	0–9999	—	—	—	—			
475	Sixth position feed amount lower 4 digits	0	0–9999	—	✓	✓	—	6. speed (Pr. 26)		
476	Sixth position feed amount upper 4 digits	0	0–9999	—	—	—	—			
477	Seventh position feed amount lower 4 digits	0	0–9999	—	✓	✓	✓	7. speed (Pr. 27)		
478	Seventh position feed amount upper 4 digits	0	0–9999	—	—	—	—			
479	Eighth position feed amount lower 4 digits	0	0–9999	✓	—	—	—	8. speed (Pr. 232)		
480	Eighth position feed amount upper 4 digits	0	0–9999	—	—	—	—			
481	Ninth position feed amount lower 4 digits	0	0–9999	✓	—	—	✓	9. speed (Pr. 233)		
482	Ninth position feed amount upper 4 digits	0	0–9999	—	—	—	—			
483	Tenth position feed amount lower 4 digits	0	0–9999	✓	—	✓	—	10. speed (Pr. 234)		
484	Tenth position feed amount upper 4 digits	0	0–9999	—	—	—	—			
485	Eleventh position feed amount lower 4 digits	0	0–9999	✓	—	✓	✓	11. speed (Pr. 235)		
486	Eleventh position feed amount upper 4 digits	0	0–9999	—	—	—	—			
487	Twelfth position feed amount lower 4 digits	0	0–9999	✓	✓	—	—	12. speed (Pr. 236)		
488	Twelfth position feed amount upper 4 digits	0	0–9999	—	—	—	—			
489	Thirteenth position feed amount lower 4 digits	0	0–9999	✓	✓	—	✓	13. speed (Pr. 237)		
490	Thirteenth position feed amount upper 4 digits	0	0–9999	—	—	—	—			
491	Fourteenth position feed amount lower 4 digits	0	0–9999	✓	✓	✓	—	14. speed (Pr. 238)		
492	Fourteenth position feed amount upper 4 digits	0	0–9999	—	—	—	—			
493	Fifteenth position feed amount lower 4 digits	0	0–9999	✓	✓	✓	✓	15. speed (Pr. 239)		
494	Fifteenth position feed amount upper 4 digits	0	0–9999	—	—	—	—			

The above parameters can be set when the FR-A7AP (option) is mounted.

**Setting of position feed amount by parameter**

- Set position feed amount in Pr. 465 to Pr. 494.
- The feed amount set in each parameter is selected by multi-speed terminal (RH, RM, RL, REX).
- Set (encoder resolution × speed × 4 times) for position feed amount.

**Example ▾**

For example, the formula for stopping the motor after 100 rotations using the FR-V5RU is as follows:

$$2048 \text{ (pulse/rev)} \times 100 \text{ (speed)} \times 4 = 819200 \text{ (feed amount)}$$

To set 819200 for the first position feed amount, divide the value into upper four digits and lower four digits and set 81 (decimal) in Pr. 466 (upper) and 9200 (decimal) in Pr. 465 (lower). Positioning is made with the frequency set in parameter 4.



**Position command operation by parameter**

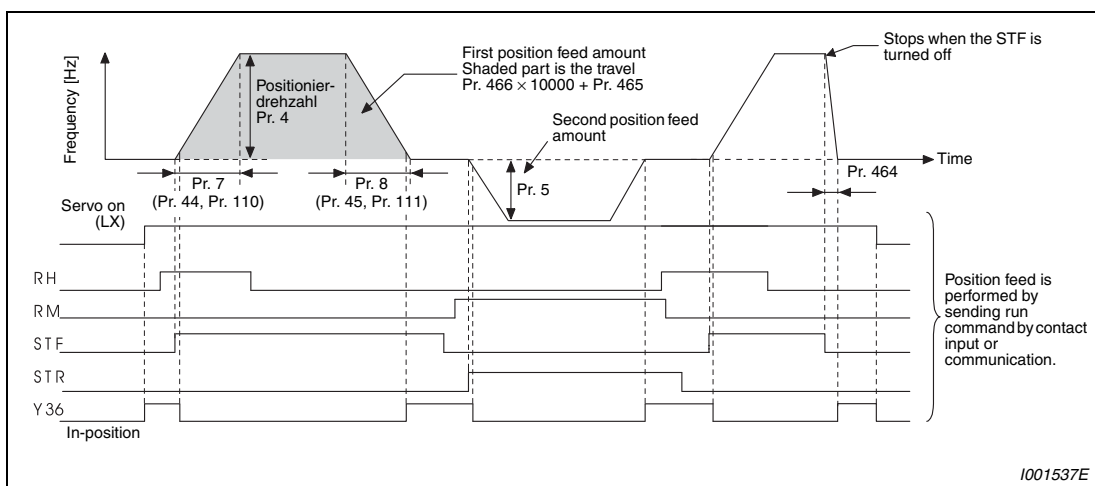

**Fig. 6-40: Position command operation by parameter**

For deceleration by turning the STF(STR) off, use Pr. 464 "Digital position control sudden stop deceleration time" to set deceleration time.

**NOTES**

- | Acceleration/deceleration time is 0.1s minimum and 360s maximum.
- | Pr. 20 "Acceleration/deceleration reference frequency" is clamped at a minimum of 16.66Hz (500r/min).
- | The acceleration/deceleration patterns for position control are all linear acceleration and the setting of Pr. 29 "Acceleration/ deceleration pattern selection" is invalid.



**CAUTION:**

**Information on multi-speed command (position command by RL, RM, RH, and REX signals) is determined at rising of the forward (reverse) command to perform position control. Therefore, set forward (reverse) command after multi-speed command (position command). Position feed is invalid if the multi-speed command is given after forward (reverse) command.**

### 6.5.3 Position control (Pr. 419, Pr. 428 to Pr. 430) by inverter pulse train input Vector

Conditional position pulse train command can be input by pulse train input and sign signal (NP) from the JOG terminal.

Pr. No.	Name	Initial Value	Setting Range	Description	Parameters referred to	Refer to Section
<b>419</b>	Position command source selection	0	0	Conditional position control function by contact input. (position command by parameter settings)	52 DU/PU main display data selection 178-189 Input terminal function selection)	6.3.2 6.15.2
			2	Conditional pulse train position command by inverter pulse train input		
<b>428</b>	Command pulse selection	0	0-2	Pulse train + sign		
			3-5			
<b>429</b>	Clear signal selection (CLR signal)	1	0	Deviation counter is cleared at edge of turning off of the clear signal (CLR) from on		
			1	Deviation counter while the clear signal (CLR) is on		
<b>430</b>	Pulse monitor selection	9999	0-5	The status of various pulses during running is displayed.		
			9999	Frequency monitor is displayed.		

The above parameters can be set when the FR-A7AP (option) is mounted.

#### Operation

Turning on the servo on signal (LX) cancels the output shutoff and the operation ready signal (RDY) turns on after 0.1s. Turning on the STF (forward stroke end signal) or STR (reverse stroke end signal) runs the motor according to the commanded pulse. When the forward (reverse) stroke end signal turns off, the motor does not run in that direction.

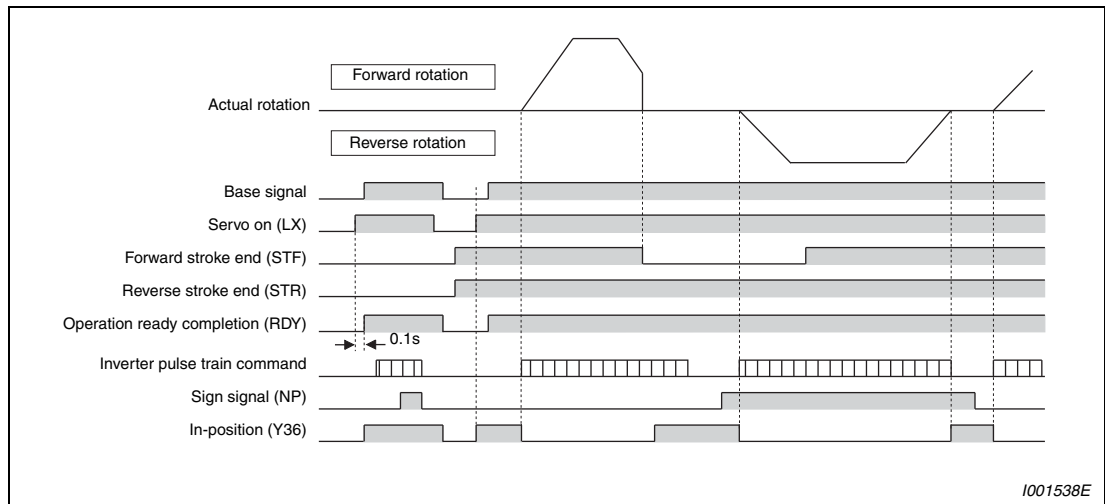









Fig. 6-41: Operation

**Pulse train form type selection (Pr. 428, NP signal)**

- Set "2" (conditional pulse train position command) in Pr. 419.
- Set "68" in Pr. 178 to Pr. 189 "Input terminal function selection" to assign conditional position pulse train sign (NP).
- Select command pulse train using Pr. 428.

Pr. 428	Command Pulse Train Type		At Forward Rotation	At Reverse Rotation
0-2	Sink logic	Pulse train + sign	JOG  NP 	JOG  NP 
3-5	Sink logic	IPulse train + sign	JOG  NP 	JOG  NP 

**Tab. 6-24:** Setting of parameter 428

- Select vector control, then select position control.

**NOTE**

When Pr. 419 "Position command source selection" = 2 (conditional pulse train position command), JOG terminal serves as conditional position pulse train input terminal regardless of the Pr. 291 "Pulse train input selection" setting.

**Selection of clear signal (Pr. 429, CLR signal)**

- Use this function to zero the droop pulse for home position operation, etc.
- When "0" is set in Pr. 429, the deviation counter is cleared at the edge of turning on of the clear signal (CLR). In addition, the CLR signal turns on in synchronization with zero pulse signal of the encoder at home position operation, etc., deviation counter is cleared.
- For the terminal used for CLR signal, set "69" in any of Pr. 178 to Pr. 189 "Input terminal function selection" to assign the function.

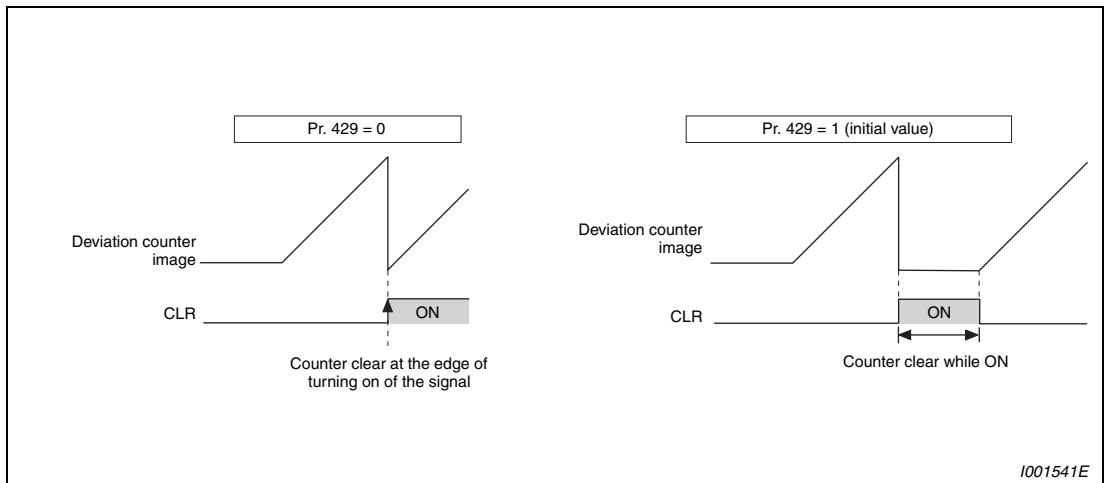

**Fig. 6-42:** Clear the droop pulse

**Pulse monitor selection (Pr. 430)**

The status of various pulses during running is displayed. Set "6" in Pr. 52 "DU/PU main display data selection" to display output frequency monitor.

Pr. 430	Description	Display Range (FR-DU07)	Display Range (FR-PU04/FR-PU07)
0	The cumulative command pulse value is displayed.	Lower 4 digits	Lower 5 digits
1		Upper 4 digits	Upper 5 digits
2	The cumulative feedback pulse value is displayed.	Lower 4 digits	Lower 5 digits
3		Upper 4 digits	Upper 5 digits
4	The droop pulses are monitored.	Lower 4 digits	Lower 5 digits
5		Upper 4 digits	Upper 5 digits
9999	Frequency monitor is displayed. (initial value)		

**Tab. 6-25:** Pulse monitor selection

**NOTES**

Count the number of pulses when the servo is on.

The cumulative pulse value is cleared when the base is shut off or the clear signal (CLR) is turned on.

Changing the terminal assignment using Pr. 178 to Pr. 189 "Input terminal function selection" may affect the other functions. Make setting after confirming the function of each terminal.



## 6.5.4 Setting of the electronic gear (Pr. 420, Pr. 421, Pr. 424) Vector

Set the ratio of the machine side gear and the motor side gear.

Pr. No.	Name	Initial Value	Setting Range	Description	Parameters referred to	Refer to Section
<b>420</b>	Command pulse scaling factor numerator	1	0–32767 ①	Set the electric gear. Pr. 420 is a numerator and Pr. 421 is a denominator.	422 Position loop gain	6.5.6
<b>421</b>	Command pulse scaling factor denominator	1	0–32767 ①			
<b>424</b>	Position command acceleration/deceleration time constant	0s	0–50 s	Used when rotation has become unsmooth at a large electronic gear ratio (about 10 times or more) and low speed.		

The above parameters can be set when the FR-A7AP (option) is mounted.

- ① When the operation panel (FR-DU07) is used, the maximum setting is 9999. When a parameter unit is used, up to the maximum value within the setting range can be set.

### Calculation of the gear ratio (Pr. 420, Pr. 421)

The position resolution (travel per pulse  $\Delta l$  [mm]) is determined by the travel per motor revolution  $\Delta s$  [mm] and the feedback pulses  $P_f$  [pulse/rev] of the detector, and is represented by the following expression.

$$\Delta l = \frac{\Delta s}{P_f}$$

$\Delta l$ : travel per pulse [mm]

$\Delta s$ : travel per motor rotation [mm]

$P_f$ : number of feedback pulses [pulse/rev] (number of pulses after multiplying the number of encoder pulses by four)

Using the parameters, the travel per command pulse can be set separately to set the travel per command pulse without a fraction.

$$\Delta l = \frac{\Delta s}{P_f} \times \frac{\text{Pr. 420}}{\text{Pr. 421}}$$

In addition, the relationship between the motor speed and internal command pulse frequency is as follows:

$$f_o \times \frac{\text{Pr. 420}}{\text{Pr. 421}} = P_f \times \frac{N_o}{60}$$

$f_o$ : Internal command pulse frequency [pps]

$N_o$ : Motor speed [r/min]

#### NOTE

Set the electronic gear in the range of 1/50 to 20. Note that too small a value will decrease the speed command and too large a value will increase the speed ripples.

**Examples** ▾**Setting example 1:**

The travel per pulse is  $\Delta l = 0.01$  mm in a drive system where the ballscrew pitch  $PB = 10$  (mm) and the reduction ratio  $1/n = 1$  and the electronic gear ratio is  $\Delta s = 10$  (mm) when the number of feedback pulses  $Pf = 4000$  (pulse/rev).

According to the following expression,

$$\begin{aligned}\Delta l & \square \frac{\Delta s}{Pf} \times \frac{\text{Pr. 420}}{\text{Pr. 421}} \\ \frac{\text{Pr. 420}}{\text{Pr. 421}} & \square \Delta l \times \frac{Pf}{\Delta s} \\ & \square 0.01 \times \frac{4000}{10} \\ & \square \frac{4}{1}\end{aligned}$$

Therefore, set "4" in Pr. 420 and "1" in Pr. 421 .

**Setting example 2:**

Find the internal command pulse frequency of the dedicated motor rated speed.

Note that the command pulse scaling factor  $\text{Pr. 420}/\text{Pr. 421} = 1$ .

Assuming that the number of encoder pulses is 2048 (pulses/rev) (feedback pulse  $Pf = 2048 \times 4$ ),

$$\begin{aligned}f_o & \square 2048 \times 4 \times \frac{N_o}{60} \times \frac{\text{Pr. 421}}{\text{Pr. 420}} \\ & \square 204800\end{aligned}$$

Therefore, the internal command pulse frequency is 204800 (pps).

△

Relationship between position resolution  $\Delta l$  and overall accuracy

Since overall accuracy (positioning accuracy of machine) is the sum of electrical error and mechanical error, normally take measures to prevent the electrical system error from affecting the overall error. As a guideline, refer to the following relationship.

$$\Delta l < \left( \frac{1}{5} \text{ to } \frac{1}{10} \right) \times \Delta \varepsilon$$

$\Delta \varepsilon$ : positioning accuracy

**Stopping characteristic of motor**

When parameters are used to run the motor, the internal command pulse frequency and motor speed have the relationship as shown in Fig. 6-39, and as the motor speed decreases, pulses are accumulated in the deviation counter of the inverter. These pulses are called droop pulses ( $\epsilon$ ) and the relationship between command frequency ( $f_0$ ) and position loop gain ( $K_p$ : Pr. 422) is as represented by the following expression.

$$\epsilon \square \frac{f_0}{K_p} \text{ [pulse]}$$

$$\epsilon \square \frac{204800}{25} \text{ [pulse] (rated motor speed)}$$

When the initial value of  $K_p$  is  $25 \text{ s}^{-1}$ , the droop pulses ( $\epsilon$ ) are 8192 pulses.

Since the inverter has droop pulses during running, a stop settling time ( $t_s$ ) is needed from when the command has zeroed until the motor stops. Set the operation pattern in consideration of the stop settling time.

$$t_s \square 3 \times \frac{1}{K_p} \text{ [s]}$$

When the initial value of  $K_p$  is  $25 \text{ s}^{-1}$ , the stop settling time ( $t_s$ ) is 0.12s.

The positioning accuracy  $\Delta\epsilon$  is  $(5 \text{ to } 10) \times \Delta l = \Delta\epsilon \text{ [mm]}$

**Position command acceleration/deceleration time constant (Pr. 424 )**

- When the electronic gear ratio is large (about 10 or more times) and the speed is low, rotation will not be smooth, resulting in pulse-wise rotation. At such a time, set this parameter to smooth the rotation.
- When acceleration/deceleration time cannot be provided for the command pulses, a sudden change in command pulse frequency may cause an overshoot or error excess alarm. At such a time, set this parameter to provide acceleration/deceleration time. Normally set 0.

### 6.5.5 Setting of positioning adjustment parameter (Pr. 426, Pr. 427) Vector

Pr. No.	Name	Initial Value	Setting Range	Description	Parameters referred to	Refer to Section
<b>426</b>	In-position width	100 pulses	0-32767 pulses <sup>①</sup>	When the number of droop pulses has fallen below the setting value, the in-position signal (Y36) turns on.	—	
<b>427</b>	Excessive level error	$40 \times 10^3$	0- $400 \times 10^3$	A position error excessive (E.OD) occurs when the number of droop pulses exceeds the setting.		
			9999	Function invalid		

The above parameters can be set when the FR-A7AP (option) is mounted.

<sup>①</sup> When the operation panel (FR-DU07) is used, the maximum setting is 9999. When a parameter unit is used, up to the maximum value within the setting range can be set.

#### In-position width (Pr. 426 )

The Y36 signal acts as an in-position signal.

When the number of droop pulses has fallen below the setting value, the in-position signal (Y36) turns on. For the Y36 signal, assign the function by setting "36" (source logic) or "136" (sink logic) in any of Pr. 190 to Pr. 196 "Output terminal function selection".

#### Excessive level error (Pr. 427)

When droop pulses exceed the value set in Pr. 427, position error large occurs and displays an error (E.OD) to stop the inverter. When you decreased the Pr. 422 "Position loop gain setting", increase the error excessive level setting. Also decrease the setting when you want to detect an error slightly earlier under large load.

When "9999" is set in Pr. 427, position error large (E.OD) does not occur regardless of droop pulses.

## 6.5.6 Gain adjustment of position control (Pr. 422, Pr. 423, Pr. 425) Vector

Pr. No.	Name	Initial Value	Setting Range	Description	Parameters referred to	Refer to Section
<b>422</b>	Position loop gain	$25s^{-1}$	$0-150s^{-1}$	Set the gain of the position loop.	7 Acceleration time 8 Deceleration time	6.11.1 6.11.1
<b>423</b>	Position feed forward gain	0%	0-100%	Function to cancel a delay caused by the droop pulses of the deviation counter.	72 PWM frequency selection 800 Control method selection	6.19.1 6.2.2
<b>425</b>	Position feed forward command filter	0s	0-5s	Enters the primary delay filter in response to the feed forward command.	802 Pre-excitation selection 819 Easy gain tuning selection 820 Speed control P gain 1 821 Speed control integral time 1	6.13.1 6.3.3 6.3.3 6.3.3

The above parameters can be set when the FR-A7AP (option) is mounted.

### Position loop gain (Pr. 422)

- Make adjustment when any of such phenomena as unusual vibration, noise and overcurrent of the motor/machine occurs.
- Increasing the setting improves trackability for the position command and also improves servo rigidity at a stop, but oppositely makes an overshoot and vibration more liable to occur.
- Normally set this parameter within the range about 5 to 50.

Phenomenon/Condition	Adjustment Method	
Slow response	Increase the Pr. 422 value.	
	Pr. 422	Increase the value $3s^{-1}$ by $3s^{-1}$ until just before an overshoot, stop-time vibration or other instable phenomenon occurs, and set about 0.8 to 0.9 of that value.
Overshoot, stop-time vibration or other instable phenomenon occurs.	Decrease the Pr. 422 value.	
	Pr. 422	Decrease the value $3s^{-1}$ by $3s^{-1}$ until just before an overshoot, stop-time vibration or other instable phenomenon does not occur, and set about 0.8 to 0.9 of that value.

**Tab. 6-26:** Setting of parameter 422

### Position feed forward gain (Pr. 423)

- This function is designed to cancel a delay caused by the droop pulses of the deviation counter.
- When a tracking delay for command pulses poses a problem, increase the setting gradually and use this parameter within the range where an overshoot or vibration will not occur.
- This function has no effects on servo rigidity at a stop.
- Normally set this parameter to 0.

## Troubleshooting

	Phenomenon	Cause	Countermeasures
1	Motor does not rotate.	<p>(1) The phase sequence of the motor or encoder wiring is wrong.</p> <p>(2) The control mode selection Pr. 800 setting is improper.</p> <p>(3) The servo on signal or stroke end signal (STF, STR) is not input.</p> <p>(4) Command pulse, position pulse sign (NP) are not correctly input.</p> <p>(5) Pr. 419 "Position command source" selection setting is not correct.</p> <p>(6) When "0" is set in Pr. 419 "Position command source selection", the settings of position feed amount in Pr. 465 to Pr. 494 are not correct.</p>	<p>(1) Check the wiring. (Refer to page 3-38.)</p> <p>(2) Check the Pr. 800 setting. (Refer to section 6.2.2.)</p> <p>(3) Check that the signals are input normally.</p> <p>(4)-1 Check that the command pulses are input normally. (Check the cumulative command pulse value in Pr. 430.)</p> <p>(4)-2 Check the command pulse form and command pulse selection, Pr. 428, setting.</p> <p>(4)-3 Check that the position pulse sign (NP) is assigned to the input terminal. (inverter pulse input)</p> <p>(5) Check the position command source selection in Pr. 419.</p> <p>(6) Check the position feed amount in Pr. 465 to Pr. 494.</p>
2	Position shift occurs.	<p>(1) The command pulses are not input correctly.</p> <p>(2) The command is affected by noise. Or the encoder feedback signal is compounded with noise.</p>	<p>(1)-1 Check the command pulse form and command pulse selection, Pr. 428 setting.</p> <p>(1)-2 Check that the command pulses are input normally. (Check the cumulative command pulse value in Pr. 430 )</p> <p>(1)-3 Check that the position pulse sign (NP) is assigned to the input terminal. (inverter pulse input)</p> <p>(2)-1 Decrease the Pr. 72 "PWM frequency selection" value.</p> <p>(2)-2 Change the earthing (grounding) point of shielded wire. Or leave the cable suspended.</p>
3	Motor or machine hunts.	<p>(1) The position loop gain is high.</p> <p>(2) The speed gain is high.</p>	<p>(1) Decrease the Pr. 422 value.</p> <p>(2)-1 Perform easy gain tuning.</p> <p>(2)-2 Decrease Pr. 820 and increase Pr. 821.</p>
4	Machine operation is unstable.	<p>(1) The acceleration/deceleration time setting has adverse effect.</p>	<p>(1) Decrease Pr. 7 and Pr. 8.</p>

Tab. 6-27: Troubleshooting

6.5.7 Troubleshooting for when position control is not exercised normally Vector

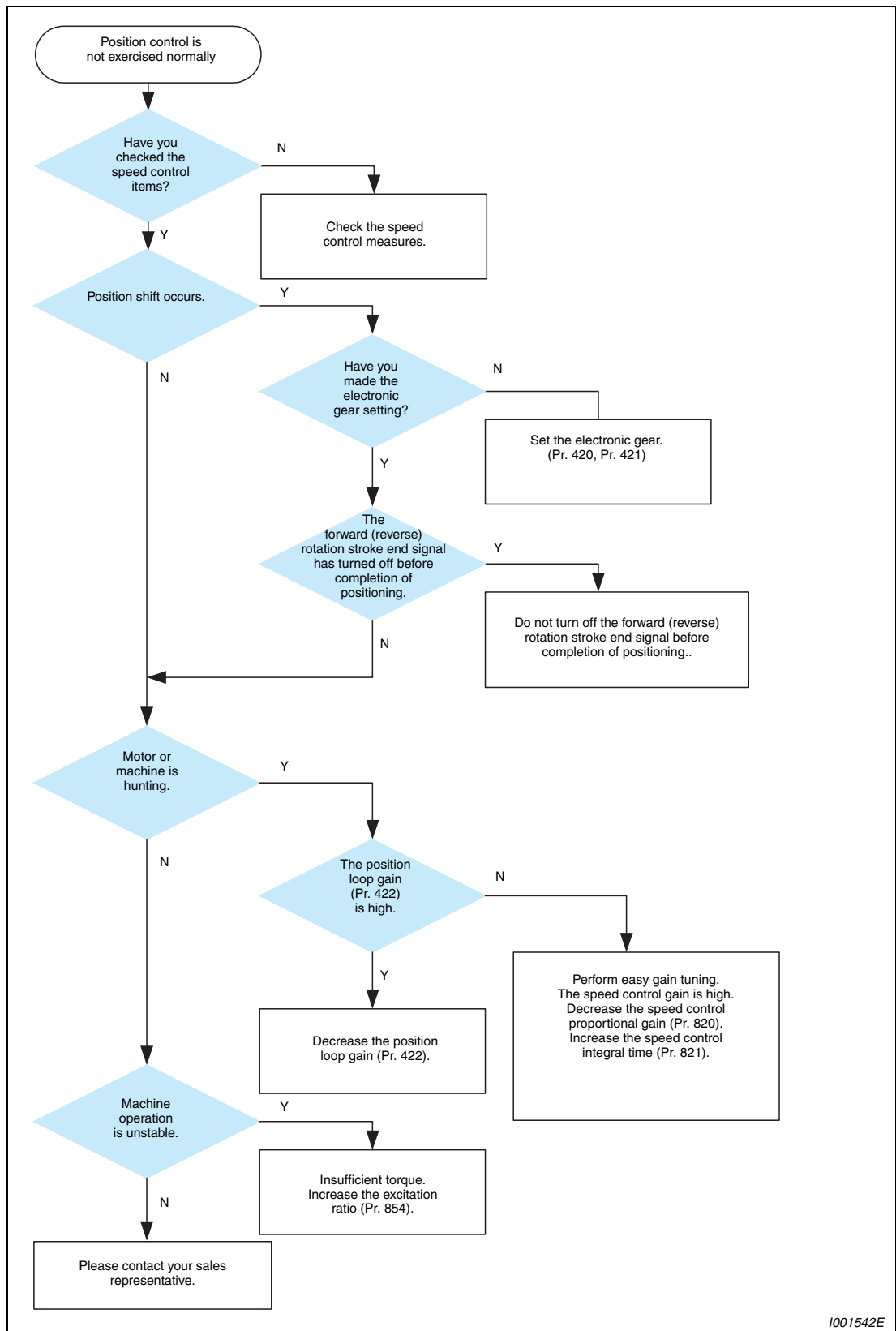

Fig. 6-43: Troubleshooting for when position control is not exercised normally

**NOTE** | The speed command of position control relates to speed control. (Refer to section 6.3.1).

## 6.6 Adjustment of real sensorless vector control, vector control

Purpose	Parameter that should be Set		Refer to Section
Stabilize speed and feedback signal	Speed detection filter Torque detection filter	Pr. 823, Pr. 827, Pr. 833, Pr. 837	6.6.1
Change the excitation ratio	Excitation ratio	Pr. 854	6.6.2

### 6.6.1 Speed detection filter and torque detection filter (Pr. 823, Pr. 827, Pr. 833, Pr. 837) Sensorless Vector

Set the time constant of the primary delay filter relative to the speed feedback signal and torque feedback signal. Since this function reduces the speed loop response, use it with the initial value.

Pr. No.	Name	Initial Value	Setting Range	Description	Parameters referred to	Refer to Section
<b>823</b>	Speed detection filter 1 <sup>①</sup>	0.001s	0	Without filter	—	
			0.001–0.1s	Set the time constant of the primary delay filter relative to the speed feedback signal.		
<b>827</b>	Torque detection filter 1	0s	0	Without filter		
			0.001–0.1s	Set the time constant of the primary delay filter relative to the torque feedback signal.		
<b>833</b>	Speed detection filter 2 <sup>①</sup>	9999	0–0.1s	Second function of Pr. 823 (valid when RT signal is on)		
			9999	Same as the Pr. 823 setting		
<b>837</b>	Torque detection filter 2	9999	0–0.1s	Second function of Pr. 827 (valid when RT signal is on)		
			9999	Same as the Pr. 827 setting		

<sup>①</sup> This parameter can be set when the FR-A7AP (option) is mounted.



**Stabilize speed detection (Pr. 823, Pr. 833)**

- Since the current loop response reduces, use it with the initial value. Increase the setting value gradually and adjust the value to stabilize the speed when speed ripples occur due to harmonic disturbance, etc. A too large value will run the motor unstably.
- Pr. 823 and Pr. 833 are valid only during vector control.

**Stabilize speed detection (Pr. 827, Pr. 837)**

- Since the current loop response reduces, use it with the initial value. Increase the setting value gradually and adjust the value to stabilize the speed when torque ripples occur due to harmonic disturbance, etc. A too large value will run the motor unstably.

**Use multiple primary delay filters**

- Use Pr. 833 and Pr. 837 to change the filter according to applications. Pr. 833 and Pr. 837 are valid when the RT signal is on.

**NOTES**

The RT signal acts as the second function selection signal and makes the other second functions valid. (Refer to section 6.14.3.)

The RT signal is assigned to the RT terminal in the initial setting. By setting "3" in any of Pr. 178 to Pr. 189 "Input terminal function selection", you can assign the RT signal to the other terminal.

## 6.6.2 Excitation ratio Sensorless Vector

Decrease the excitation ratio when you want to improve efficiency under light load. (Motor magnetic noise decreases.)

Pr. No.	Name	Initial Value	Setting Range	Description	Parameters referred to	Refer to Section
<b>854</b>	Excitation ratio	100%	0-100%	Set the excitation ratio under no load.	—	

Note that the rise of output torque becomes slow if excitation ratio is decreased. This function is appropriate for applications as machine tools which repeat rapid acceleration/deceleration up to high speed.

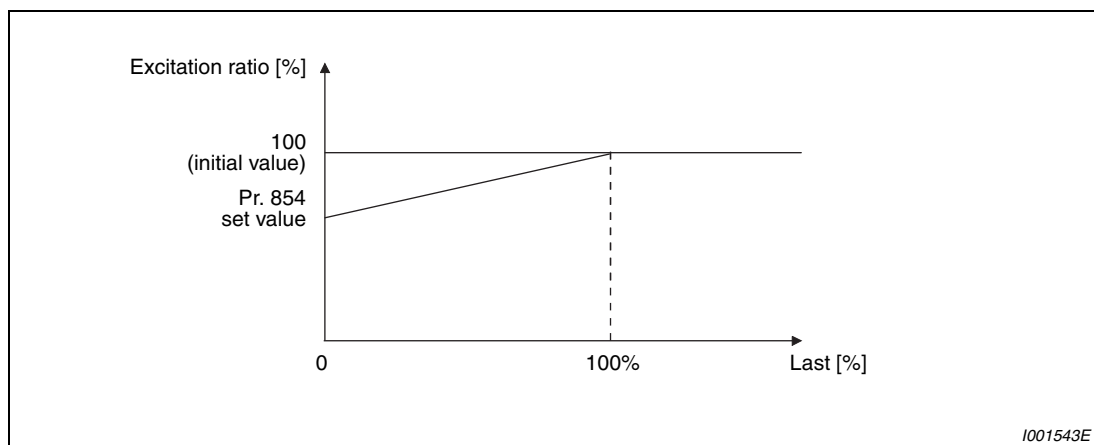

**Fig. 6-44:** Setting of the excitation ratio

### NOTE

When "1" (magnetic flux with terminal) is set in Pr. 858 "Terminal 4 function assignment" or Pr. 868 "Terminal 1 function assignment", the Pr. 854 setting is made invalid.

## 6.7 Adjust the output torque of the motor (current)

Purpose	Parameter that should be Set		Refer to Section
Set starting torque manually	Manual torque boost	Pr. 0, Pr. 46, Pr. 112	6.7.1
Automatically control output current according to load	Advanced magnetic flux vector control	Pr. 71, Pr. 80, Pr. 81, Pr. 89, Pr. 450, Pr. 451, Pr. 453, Pr. 454, Pr. 569, Pr. 800	6.7.2
Compensate for motor slip to secure low-speed torque	Slip compensation	Pr. 245–Pr. 247	6.7.3
Limit output current to prevent inverter trip	Stall prevention operation	Pr. 22, Pr. 23, Pr. 66, Pr. 154, Pr. 156, Pr. 157	6.7.4
Change the overload current rating specifications	Multiple rating setting	Pr. 570	6.7.5

### 6.7.1 Manual torque boost (Pr. 0, Pr. 46, Pr. 112)

You can compensate for a voltage drop in the low-frequency region to improve motor torque reduction in the lowspeed range.

Motor torque in the low-frequency range can be adjusted to the load to increase the starting motor torque.

Three types of starting torque boost can be changed by switching terminals.

Pr. No.	Name	Initial Value		Setting Range	Description	Parameters referred to	Refer to Section
<b>0</b>	Torque boost	00023/ 00038	6%	0–30%	Set the output voltage at 0Hz as %.	3 Base frequency 19 Base frequency voltage 71 Applied motor 178–189 Input terminal function selection	6.9.1 6.9.1 6.12.2 6.14.1
		00052 to 00126	4%				
		00170/ 00250	3%				
		00310 to 01800	2%				
		01800 or größer	1%				
<b>46</b>	Second torque boost	9999		0–30%	Set the torque boost value when the RT signal is on.		
				9999	Without second torque boost		
<b>112</b>	Third torque boost	9999		0–30%	Set the torque boost value when the X9 signal is on.		
				9999	Without third torque boost		

### Starting torque adjustment

On the assumption that Pr. 19 "Base frequency voltage" is 100%, set the output voltage at 0Hz in % to Pr. 0 (Pr. 46, Pr. 112).

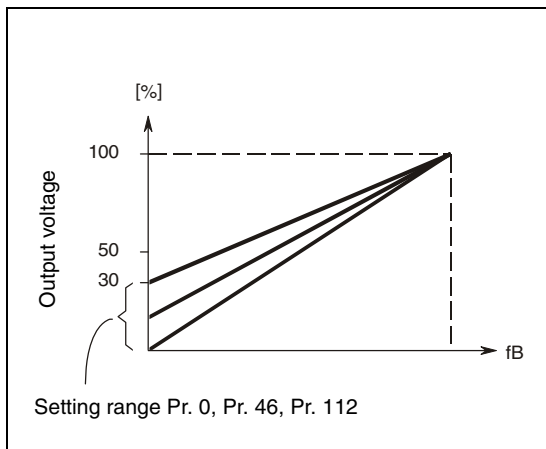

**Fig. 6-45:**

*Relationship between output frequency and output voltage*

1000001C



#### CAUTION:

**Adjust the parameter little by little (about 0.5%), and check the motor status each time. If the setting is too large, the motor will overheat. The guideline is about 10% at the greatest.**

**The requirements of the motor manufacturer must also be observed.**

### Set multiple base frequencies (RT signal, X9 signal, Pr. 46, Pr. 112)

Use the second (third) torque boost when changing the torque boost according to application or when using multiple motors by switching between them by one inverter.

Pr. 46 "Second torque boost" is made valid when the RT signal turns on. The RT signal is assigned to the RT terminal by any of Pr. 178 to Pr. 189 "Input terminal function selection".

Pr. 112 "Third torque boost" is valid when the X9 signal is on. For the terminal used for X9 signal input, set "9" in any of Pr. 178 to Pr. 189 "Input terminal function selection" to assign the X9 signal function.

**NOTES**

The RT(X9) signal acts as the second (third) function selection signal and makes the other second (third) functions valid. (Refer to section 6.14.3.)

The RT signal is assigned to the RT terminal in the default setting. By setting "3" in any of Pr. 178 to Pr. 189 "Input terminal function selection", you can assign the RT signal to the other terminal.

Increase the setting when the distance between the inverter and motor is long or when motor torque is insufficient in the low-speed range. If the setting is too large, an overcurrent trip may occur. Überstromauslösung kommen.

The Pr. 0, Pr. 46, Pr. 112 settings are valid only when V/f control is selected.

When using the inverter dedicated motor (constant torque motor) with the 00170 or 00250, set the torque boost value to 2%. If the initial set Pr. 71 value is changed to the setting for use with a constant-torque motor, the Pr. 0 setting changes to the corresponding value in above.

Changing the terminal assignment using Pr. 178 to Pr. 189 "Input terminal function selection" may affect the other functions. Please make setting after confirming the function of each terminal.

## 6.7.2 Advanced magnetic flux vector control (Pr. 71, Pr. 80, Pr. 81, Pr. 89, Pr. 450, Pr. 451, Pr. 453, Pr. 454, Pr. 569, Pr. 800) Magnetic flux

Advanced magnetic flux vector control can be selected by setting the capacity, number and type of motor to be used in Pr. 80 and Pr. 81.

### ● What is advanced magnetic flux vector control?

The low speed torque can be improved by providing voltage compensation so that the motor current which meets the load torque to flow. Output frequency compensation (slip compensation) is made so that the motor actual speed approximates a speed command value. Effective when load fluctuates drastically, etc.

Pr. No.	Name	Initial Value	Setting Range	Description	Parameters referred to	Refer to Section	
<b>71</b>	Applied motor	0	0-8/13-18/20/23/24/30/33/34/40/43/44/50/53/54	By selecting a standard motor or constant torque motor, thermal characteristic and motor constants of each motor are set.	71 Applied motor	6.12.2	
<b>80</b>	Motor capacity	9999	01800 or less	0.4-55kW	Set the applied motor capacity.	450 Second applied motor	6.12.2
			02160 or more	0-3600kW			
			9999	V/f control			
<b>81</b>	Number of motor poles	9999	2/4/6/8/10	Set the number of motor poles.	800 Control method selection	6.2.2	
			12/14/16/18/20	X18 signal-ON: V/f control <sup>①</sup>			Set 10 + number of motor poles.
			9999	V/f control			
<b>89</b>	Speed control gain (magnetic flux vector)	9999	0-200%	Motor speed fluctuation due to load fluctuation is adjusted during advanced magnetic flux vector control. 100% is a referenced value.	451 Second motor control method selection	6.2.2	
			9999	Gain matching with the motor set in Pr. 71.			
<b>450</b>	Second applied motor	9999	0-8/13-18/20/23/24/30/33/34/40/43/44/50/53/54	Set when using the second motor. (same specifications as Pr. 71 )	71 Applied motor	6.12.2	
			9999	Function invalid (Pr. 71 is valid)			
<b>451</b>	Second motor control method selection	9999	10/11/12	Real sensorless vector control	450 Second applied motor	6.12.2	
			20/9999	V/f control (advanced magnetic flux vector control)			
<b>453</b>	Second motor capacity	9999	01800 or less	0.4-55kW	Set the capacity of the second motor.	800 Control method selection	6.2.2
			02160 or more	0-3600kW			
			9999	V/f control			
<b>454</b>	Number of second motor poles	9999	2/4/6/8/10	Set the number of poles of the second motor.	451 Second motor control method selection	6.2.2	
			9999	V/f control			
<b>569</b>	Second motor speed control gain	9999	0-200%	Second motor speed fluctuation due to load fluctuation is adjusted during advanced magnetic flux vector control. 100% is a referenced value.	450 Second applied motor	6.12.2	
			9999	Gain matching with the motor set in Pr. 450.			
<b>800</b>	Control method selection	20	0-5	Vector control	71 Applied motor	6.12.2	
			9	Vector control test operation			
			10/11/12	Real sensorless vector control			
			20	V/f control (advanced magnetic flux vector control)			

<sup>①</sup> Use Pr. 178 to Pr. 189 to assign the terminals used for the X18 and MC signal.

If the following conditions are not satisfied, select V/f control since malfunction such as insufficient torque and uneven rotation may occur.

- The motor capacity should be equal to or one rank lower than the inverter capacity. (note that the capacity should be 0.4kW or more)
- Motor to be used is either Mitsubishi standard motor (SF-JR, SF-HR two-pole, four-pole, six-pole 0.4kW or more) or Mitsubishi constant torque motor (SF-JRCA, SF-HRCA four-pole 0.4kW to 55kW). When using a motor other than the above (SF-TH, other manufacturer's motors, etc.), perform offline auto tuning without fail.
- Single-motor operation (one motor run by one inverter) should be performed.
- The wiring length from inverter to motor should be within 30m. (Perform offline auto tuning in the state where wiring work is performed when the wiring length exceeds 30m.)
- Do not use an option sine wave filter (MT-BSL/BSC) between the inverter and motor.

## Selection method of advanced magnetic flux vector control

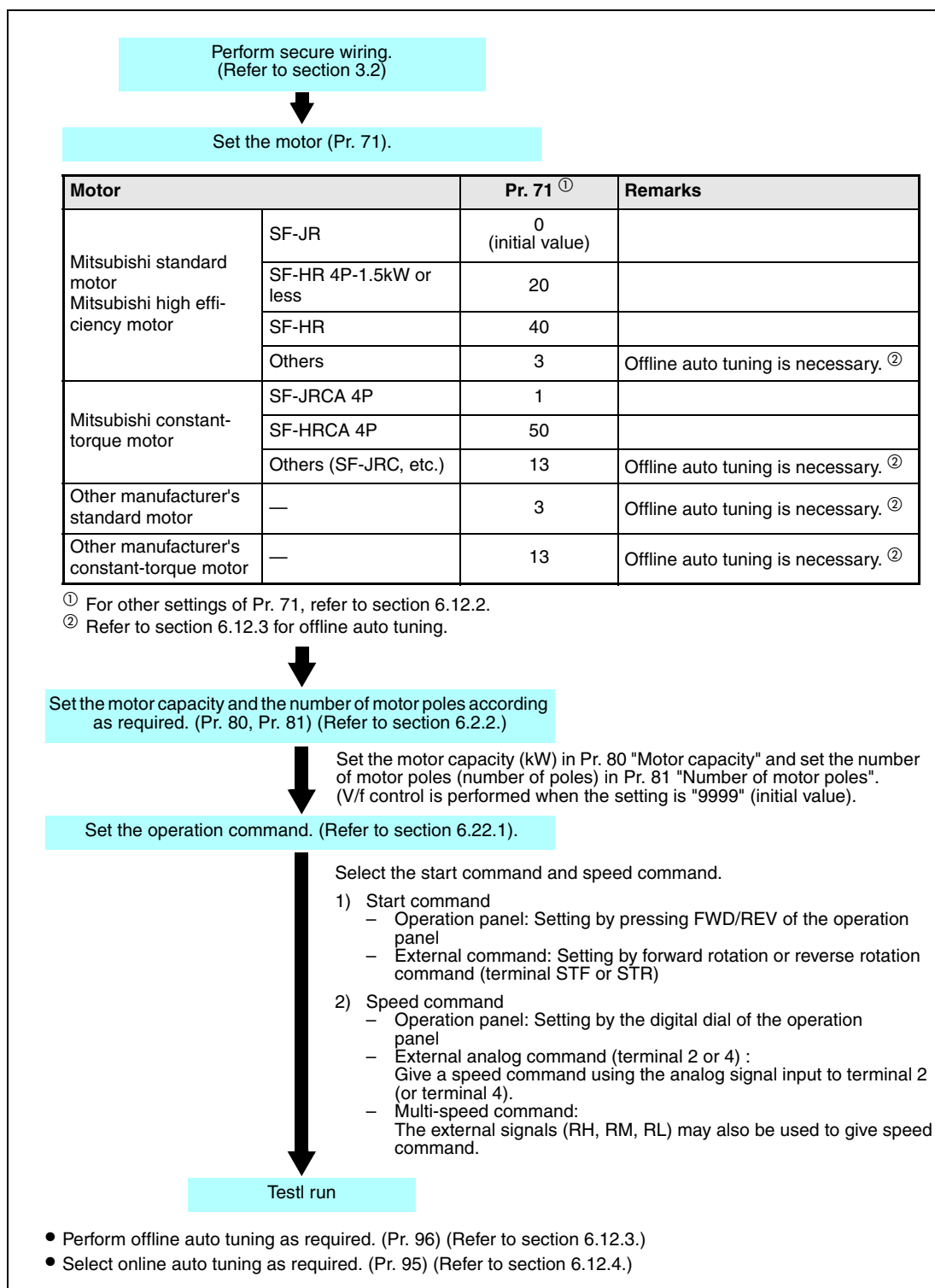

Fig. 6-46: Selection of the advanced magnetic flux vector control

## NOTE

When higher accuracy operation is necessary, set online auto tuning after performing offline auto tuning and select real sensorless vector control.



**NOTES**

Uneven rotation slightly increases as compared to the V/f control. (It is not suitable for machines such as grinding machine and wrapping machine which requires less uneven rotation at low speed.)

When a surge voltage suppression filter (FR-ASF-H) is connected between the inverter and motor, output torque may decrease. (01800 or less)

When terminal assignment is changed using Pr. 178 to Pr. 189 "Input terminal function selection", the other functions may be affected. Make setting after confirming the function of each terminal.

**Adjust the motor speed fluctuation at load fluctuation (speed control gain)**

The motor speed fluctuation at load fluctuation can be adjusted using Pr. 89. (It is useful when the speed command does not match the motor speed after the FR-A500(L) series inverter is replaced with the FR-A700 series inverter, etc.)

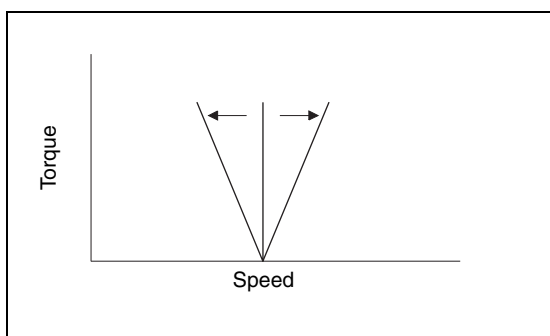

**Fig. 6-47:**  
Adjusting speed fluctuations

1001544E

**Advanced magnetic flux vector control is performed with two motors**

- Turning the RT signal on allows the second motor to be controlled.
- Set the second motor in Pr. 450 Second applied motor. (Initial setting is "9999" (without second applied motor). Refer to section 6.12.2.)

Function	RT signal ON (second motor)	RT signal OFF (first motor)
Applied motor	Pr. 450	Pr. 71
Motor capacity	Pr. 453	Pr. 80
Number of motor poles	Pr. 454	Pr. 81
Speed control gain	Pr. 569	Pr. 89
Control method selection	Pr. 451	Pr. 800

**Tab. 6-28:** Switching the parameters by using the RT signal

**NOTES**

The RT signal acts as the second function selection signal and makes the other second functions valid. (Refer to section 6.14.3.)

The RT signal is assigned to the RT terminal in the default setting. By setting "3" in any of Pr. 178 to Pr. 189 "Input terminal function selection", you can assign the RT signal to the other terminal.

Changing the terminal assignment using Pr. 178 to Pr. 189 "Input terminal function selection" may affect the other functions. Please make setting after confirming the function of each terminal.

### 6.7.3 Slip compensation (Pr. 245 to Pr. 247)

The inverter output current may be used to assume motor slip to keep the motor speed constant.

Pr. No.	Name	Initial Value	Setting Range	Description	Parameters referred to	Refer to Section
245	Rated slip	9999	0.01–50%	Used to set the rated motor slip.	1 Maximum Frequency 3 Base frequency	6.8.1 6.9.1
			0/9999	No slip compensation		
246	Slip compensation time constant	0.5s	0.01–10s	Used to set the slip compensation response time. When the value is made smaller, response will be faster. However, as load inertia is greater, a regenerative over voltage (E.OV□) error is more liable to occur.		
247	Constant-output region slip compensation selection	9999	0	Slip compensation is not made in the constant output range (frequency range above the frequency set in Pr. 3)		
			9999	Slip compensation is made in the constant output range.		

Slip compensation is validated when the motor rated slip calculated by the following formula is set to Pr. 245. Slip compensation is not made when Pr. 245 = 0 or 9999.

$$\text{Rated slip} = \frac{\text{Synchronous speed at base frequency} - \text{Rated speed}}{\text{Synchronous speed at base frequency}} \times 100\%$$

#### NOTE

When performing slip compensation, the output frequency may become greater than the set frequency. Set the Pr. 1 "Maximum frequency" value a little higher than the set frequency.

**6.7.4****Stall prevention operation****(Pr. 22, Pr. 23, Pr. 48, Pr. 49, Pr. 66, Pr. 114, Pr. 115, Pr. 148, Pr. 149, Pr. 154, Pr. 156, Pr. 157, Pr. 858, Pr. 868)**  

This function monitors the output current and automatically changes the output frequency to prevent the inverter from coming to an alarm stop due to overcurrent, overvoltage, etc. It can also limit stall prevention and fastresponse current limit operation during acceleration/deceleration, driving or regeneration. Invalid under real sensorless vector control or vector control.

- **Stall prevention**

If the output current exceeds the stall prevention operation level, the output frequency of the inverter is automatically varied to reduce the output current. Also the second stall prevention function can restrict the output frequency range in which the stall prevention function is valid. (Pr. 49).

- **Fast-response current limit**

If the current exceeds the limit value, the output of the inverter is shut off to prevent an overcurrent.

Pr. No.	Name	Initial Value	Setting Range	Description
22	Stall prevention operation level	150% ①	0	Stall prevention operation selection becomes invalid.
			0.1–400% ①	Set the current value at which stall prevention operation will be started.
23	Stall prevention operation level compensation factor at double speed	9999	0–200% ①	The stall operation level can be reduced when operating at a high speed above the rated frequency.
			9999	Constant according to Pr. 22
48	Second stall prevention operation current	150% ①	0	Second stall prevention operation invalid
			0.1–220% ①	The second stall prevention operation level can be set.
49	Second stall prevention operation frequency	0Hz	0	Second stall prevention operation invalid
			0.01–400Hz	Set the frequency at which stall prevention operation of Pr. 48 is started.
			9999	Pr. 48 is valid when the RT signal is on.
66	Stall prevention operation reduction starting frequency	50Hz	0–400Hz	Set the frequency at which the stall operation level is started to reduce.
114	Third stall prevention operation current	150% ①	0	Third stall prevention operation invalid
			0.1–220%	Stall prevention operation level can be changed with the X9 signal.
115	Third stall prevention operation frequency	0Hz	0	Third stall prevention operation invalid
			0.01–400Hz	Set the frequency at which stall prevention operation when the X9 signal is on starts.
148	Stall prevention level at 0V input	150% ①	0–220% ①	Stall prevention operation level can be changed by the analog signal input to terminal 1 (terminal 4).
149	Stall prevention level at 10V input	200% ①	0–220% ①	
154	Voltage reduction selection during stall prevention operation	1	0	With voltage reduction
			1	Without voltage reduction
156	Stall prevention operation selection	0	0–31/ 100/101	You can select whether stall prevention operation and fast-response current limit operation will be performed or not.
157	OL signal output timer	0 s	0–25s	Set the output start time of the OL signal output when stall prevention is activated.
			9999	Without the OL signal output
858	Terminal 4 function assignment	0	0/1/4/9999	By setting "4", the stall prevention operation level can be changed with a signal to terminal 4.
859	Terminal 1 function assignment	0	0–6/9999	By setting "4", the stall prevention operation level can be changed with a signal to terminal 1.

Parameters referred to	Refer to Section
22 Torque limit level	6.3.2
73 Analog input selection	6.20.2
178–189 Input terminal function selection	6.14.1
190–196 Output terminal function selection	6.14.5
570 Multiple rating setting	6.7.5
858 Terminal 4 function assignment	6.20.1
868 Terminal 1 function assignment	6.20.1

① When Pr. 570 "Multiple rating setting" ≠ "2", performing all parameter clear and inverter reset changes the initial value and setting range.

### Setting of stall prevention operation level (Pr. 22)

Set in Pr. 22 the ratio of the output current to the rated inverter current at which stall prevention operation will be performed. Normally set 150% (initial value).

Stall prevention operation stops acceleration (makes deceleration) during acceleration, makes deceleration during constant speed, and stops deceleration during deceleration.

When stall prevention operation is performed, the OL signal is output.

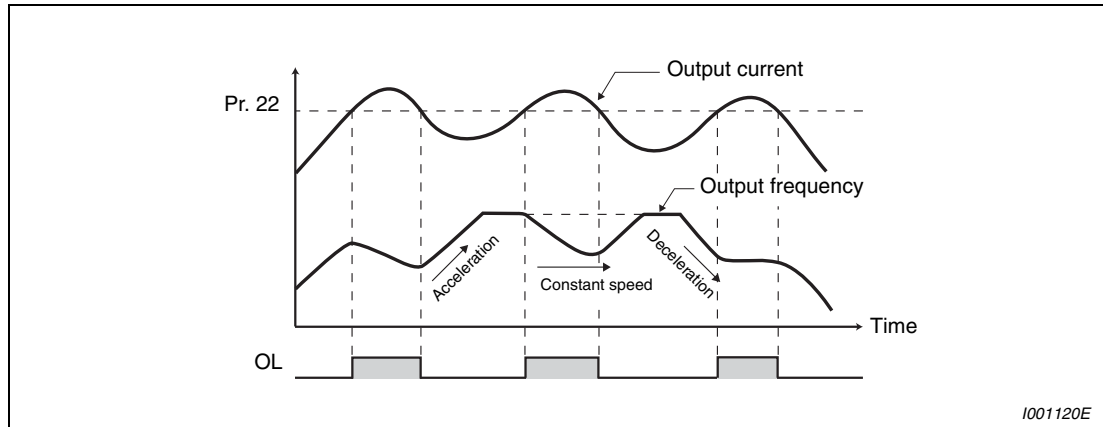

**Fig. 6-48:** Stall prevention operation example

#### NOTES

If an overload status lasts long, an inverter trip (e.g. electronic thermal relay function "E.THM") may occur.

When Pr. 156 has been set to activate the fast-response current limit (initial setting), the Pr. 22 setting should not be higher than 170%. The torque will not be developed by doing so. (When Pr. 570 = 2).

When real sensorless vector control or vector control is selected using Pr. 800 "Control method selection", Pr. 22 serves as torque limit level. For the 00126 or less, the Pr. 22 setting changes from 150% (initial value) to 200%.

**Stall prevention operation signal output and output timing adjustment (Pr. 157)**

When the output power exceeds the stall prevention operation level and stall prevention is activated, the stall prevention operation signal (OL signal) turns on for longer than 100ms. When the output power falls to or below the stall prevention operation level, the output signal turns off.

Use Pr. 157 "OL signal output timer" to set whether the OL signal is output immediately or after a preset period of time.

This operation is also performed when the regeneration avoidance function (over voltage stall) is executed.

Pr. 157 Setting	Description
0 (Initial setting)	Output immediately.
0.1–25s	Output after the set time (s) has elapsed.
9999	Not output.

**Tab. 6-29:** Setting of parameter 157

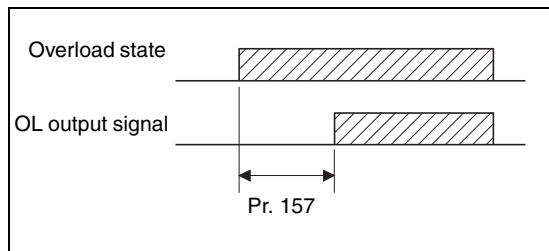

**Fig. 6-49:**  
Output of the OL signal

1001330E

**NOTES**

The OL signal is assigned to the terminal OL in the initial setting. The OL signal can also be assigned to the other terminal by setting "3" (source logic) or "103" (sink logic) to any of Pr. 190 to Pr. 196 "Output terminal function selection".

If the frequency has fallen to 0.5Hz by stall prevention operation and remains for 3s, an alarm (E.OLT) appears to shutoff the inverter output.

When terminal assignment is changed using Pr. 190 to Pr. 196 "Output terminal function selection", the other functions may be affected. Please make setting after confirming the function of each terminal.

**Setting of stall prevention operation in high frequency region (Pr. 22, Pr. 23, Pr. 66)**

During high-speed operation above the rated motor frequency, acceleration may not be made because the motor current does not increase. If operation is performed in a high frequency range, the current at motor lockup becomes smaller than the rated output current of the inverter, and the protective function (OL) is not executed if the motor is at a stop.

To improve the operating characteristics of the motor in this case, the stall prevention level can be reduced in the high frequency region. This function is effective for performing operation up to the high-speed range on a centrifugal separator etc.

Pr. 23 sets the change in the current limiting in the frequency range starting at the frequency set by Pr. 66. For example, if Pr. 66 is set to 75Hz the motor stall prevention operation level at an output frequency of 150Hz will be reduced to 75% when Pr. 23 is set to 100%, and to 66% when Pr. 23 is set to 50% (see the formula below). Generally Pr. 66 is set to 50Hz and Pr. 23 to 100%.

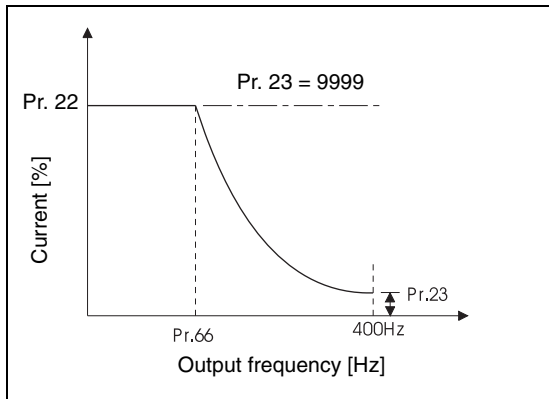

**Fig. 6-50:**  
Stall prevention operation level

I001121C

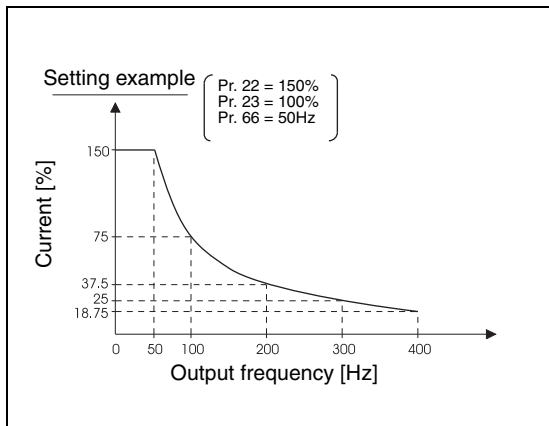

**Fig. 6-51:**  
Stall prevention operation level when  
Pr. 22 = 150 %, Pr. 23 = 100 % and  
Pr. 66 = 50 Hz

I001545C

Formula for stall prevention operation level:

$$\text{Stall prevention operation level [\%]} = A \times B \times \left[ \frac{\text{Pr. 22} \times A}{\text{Pr. 22} \times B} \right] \times \left[ \frac{\text{Pr. 23} \times 100}{100} \right]$$

$$\text{where } A = \frac{\text{Pr. 66 [Hz]} \times \text{Pr. 22 [\%]}}{\text{Output frequency [Hz]}}, B = \frac{\text{Pr. 66 [Hz]} \times \text{Pr. 22 [\%]}}{400\text{Hz}}$$

When Pr. 23 "Stall prevention operation level compensation factor at double speed" = 9999 (initial value), the stall prevention operation level is kept constant at the Pr. 22 setting up to 400Hz.

**Set multiple stall prevention operation levels (Pr. 48, Pr. 49, Pr. 144, Pr. 115)**

Setting "9999" in Pr. 49 "Second stall prevention operation frequency" and turning the RT signal on make Pr. 48 "Second stall prevention operation current" valid.

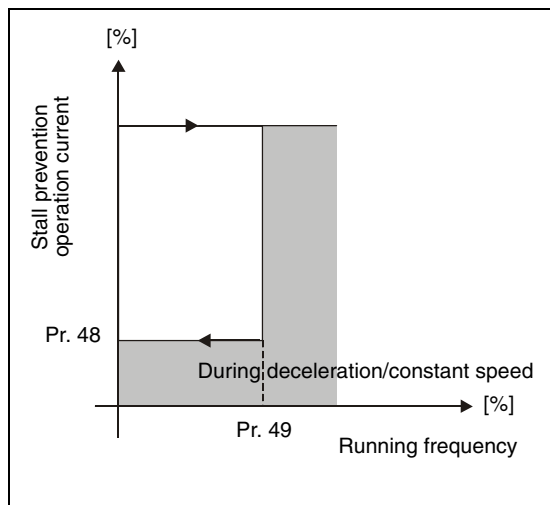

**Fig. 6-52:**  
Second stall prevention operation current setting example

1000022C

In Pr. 48 (Pr. 114), you can set the stall prevention operation level at the output frequency from 0Hz to that set in Pr. 49 (Pr. 115). During acceleration, however, the operation level is as set in Pr. 22.

This function can also be used for stop-on-contact or similar operation by decreasing the Pr. 48 (Pr. 114) setting to weaken the deceleration torque (stopping torque).

Pr. 49 Setting	Operation
0 (Initial setting)	The second (third) stall prevention operation is not performed.
0.01Hz–400Hz	The second (third) stall prevention operation is performed according to the frequency. <sup>①</sup>
9999 <sup>②</sup>	The second (third) stall prevention function is performed according to the RT signal. RT signal ON ... Stall level Pr. 48 RT signal OFF ... Stall level Pr. 22

**Tab. 6-30: Settings of parameter 49**

- ① The smaller setting of the stall prevention operation levels set in Pr. 22 and Pr. 48 has a higher priority.
- ② When Pr. 868 = "4" (Stall prevention operation level analog input), the stall prevention operation level also switches from the analog input (terminal 1 input) to the stall prevention operation level of Pr. 48 when the RT signal turns on. (The second stall prevention operation level cannot be input in an analog form.)

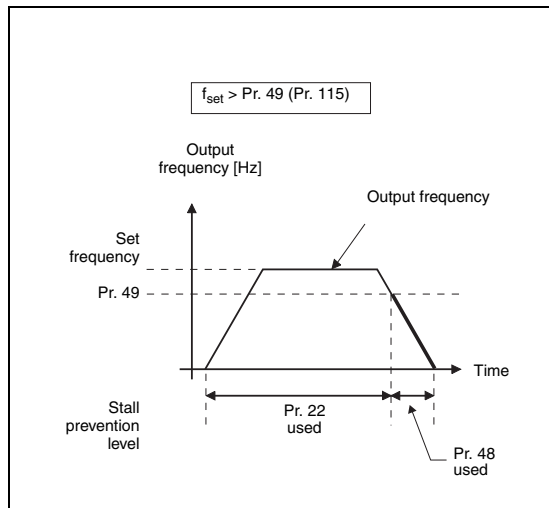

**Fig. 6-53:**

*Stall prevention level, when the set frequency exceeds the value of Pr. 49 (Pr. 115)*

I001123E

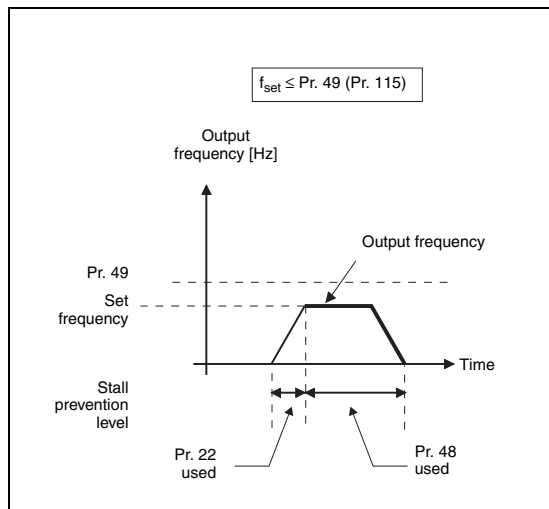
**Fig. 6-54:**

*Stall prevention level, when the set frequency is equal to or less than the value of Pr. 49 (Pr. 115)*

I001124E

**NOTES**

When  $Pr. 49 \neq 9999$  (level changed according to frequency) and  $Pr. 48 = 0\%$   
The stall prevention operation level is 0% at or higher than the frequency set in Pr. 49.

In the initial setting, the RT signal is assigned to the RT terminal. By setting "3" to any of Pr. 178 to Pr. 189 "Input terminal function selection", you can assign the RT signal to the other terminal.

Changing the terminal assignment using Pr. 178 to Pr. 189 "Input terminal function selection" may affect the other functions. Please make setting after confirming the function of each terminal.

The RT (X9) signal acts as the second (third) function selection signal and makes the other second functions valid.

### Stall prevention operation level setting by terminal 1 (terminal 4) (analog variable) (Pr. 148, Pr. 149, Pr. 858, Pr. 868)

- To set the stall prevention operation level using terminal 1 (analog input), set Pr. 868 "Terminal 1 function assignment" to "4".
- Input 0 to 5V (or 0 to 10V) to terminal 1. Select 5V or 10V using Pr. 73 "Analog input selection". When Pr. 73 = 1 (initial value), "0 to  $\pm 10V$ " is input.
- To set stall prevention operation level using terminal 4 (analog current input), set "4" in Pr. 858 "Terminal 4 function assignment". Input 0 to 20mA to terminal 4. The AU signal need not be turned on.
- Set the current limit level at the input voltage of 0V (0mA) in Pr. 148 "Stall prevention level at 0V input".
- Set the current limit level at the input voltage of 10V or 5V (20mA) in Pr. 149 "Stall prevention level at 10V input".

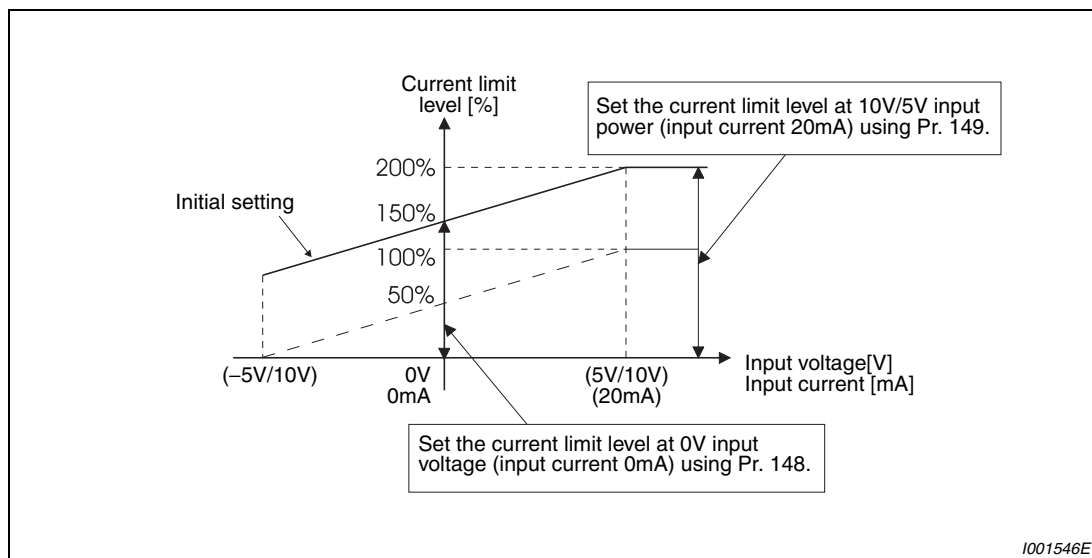

**Fig. 6-55:** Stall prevention operation level setting by terminal 1

Pr. 858	Pr. 868	Real Sensorless Vector Control (Speed Control)	
		Terminal 4 function	Terminal 1 function
0 (initial value)	0 (initial value)	Frequency command (AU signal-ON)	Frequency auxiliary
	1		Magnetic flux command
	2		—
	3		—
	4 ①		Stall prevention
	5		—
	6		Torque bias
	9999		—
1	0 (initial value)	Magnetic flux command	—
	1	—	Magnetic flux command
	2	Magnetic flux command	—
	3		—
	4 ①		Stall prevention
	5		—
	6		Torque bias
	9999		—
4 ②	0 (initial value)	Stall prevention	Frequency auxiliary
	1		Magnetic flux command
	2		—
	3	—	—
	4 ①	— ③	Stall prevention
	5	Stall prevention	—
	6		Torque bias
	9999		—
9999	—	—	—

**Tab. 6-31:** Functions of terminal 1 and 4 in dependence of the control mode

- ① When Pr. 868 = "4" (analog stall prevention), other functions of terminal 1 (auxiliary input, override function, PID control) do not function.
- ② When Pr. 858 = "4" (analog stall prevention), PID control and speed command from terminal 4 do not function even if the AU signal turns on.
- ③ When "4" (stall prevention) is set in both Pr. 858 and Pr. 868, function of terminal 1 has higher priority and terminal 4 has no function.

#### NOTE

The fast-response current limit level cannot be set.

#### To further prevent an alarm stop (Pr. 154)

When Pr. 154 is set to "0", the output voltage reduces during stall prevention operation. By making setting to reduce the output voltage, an over current trip can further become difficult to occur. Use this function where a torque decrease will not pose a problem.

Pr. 154 Setting	Description
0	Output voltage reduced
1 (Initial value)	Output voltage not reduced

**Tab. 6-32:** Settings of parameter 154

### Limit the stall prevention operation and fast-response current limit operation according to the operating status (Pr. 156)

Refer to the following table and select whether fast-response current limit operation will be performed or not and the operation to be performed at OL signal output:

Pr. 156 Setting	Fast-response Current Limit	Stall Prevention Operation Level			OL Signal Output	
		Acceleration	Constant speed	Deceleration	Without alarm	Stop with alarm „E.OLT“
0	✓	✓	✓	✓	✓	—
1	—	✓	✓	✓	✓	—
2	✓	—	✓	✓	✓	—
3	—	—	✓	✓	✓	—
4	✓	✓	—	✓	✓	—
5	—	✓	—	✓	✓	—
6	✓	—	—	✓	✓	—
7	—	—	—	✓	✓	—
8	✓	✓	✓	—	✓	—
9	—	✓	✓	—	✓	—
10	✓	—	✓	—	✓	—
11	—	—	✓	—	✓	—
12	✓	✓	—	—	✓	—
13	—	✓	—	—	✓	—
14	✓	—	—	—	✓	—
15	—	—	—	—	①	①
16	✓	✓	✓	✓	—	✓
17	—	✓	✓	✓	—	✓
18	✓	—	✓	✓	—	✓
19	—	—	✓	✓	—	✓
20	✓	✓	—	✓	—	✓
21	—	✓	—	✓	—	✓
22	✓	—	—	✓	—	✓
23	—	—	—	✓	—	✓
24	✓	✓	✓	—	—	✓
25	—	✓	✓	—	—	✓
26	✓	—	✓	—	—	✓
27	—	—	✓	—	—	✓
28	✓	✓	—	—	—	✓
29	—	✓	—	—	—	✓
30	✓	—	—	—	—	✓
31	—	—	—	—	①	①
100 D ②	✓	✓	✓	✓	✓	—
100 R ②	—	—	—	—	①	①
101 D ②	—	✓	✓	✓	✓	—
101 R ②	—	—	—	—	①	①

**Tab. 6-33:** Setting of parameter 156 (D = Driving, R = Regeneration)

- ① Since both fast-response current limit and stall prevention are not activated, OL signal and E.OLT are not output.
- ② The settings "100" and "101" allow operations to be performed in the driving and regeneration modes, respectively. The setting "101" disables the fast-response current limit in the driving mode.

**NOTES**

When the load is heavy, when the lift is predetermined, or when the acceleration/deceleration time is short, stall prevention is activated and acceleration/deceleration may not be made according to the preset acceleration/deceleration time. Set Pr. 156 and stall prevention operation level to the optimum values.

In vertical lift applications, make setting so that the fast-response current limit is not activated. Torque may not be produced, causing a drop due to gravity.

**CAUTION:**

- *Do not set a small value as the stall prevention operation current. Otherwise, torque generated will reduce.*
- *Always perform test operation.*  
*Stall prevention operation during acceleration may increase the acceleration time.*  
*Stall prevention operation performed during constant speed may cause sudden speed changes.*  
*Stall prevention operation during deceleration may increase the deceleration time, increasing the deceleration distance.*

### 6.7.5 Multiple rating (SLD = Super Light Duty, LD = Light Duty, ND = Normal Duty, HD = Heavy Duty) (Pr. 570)

You can use the inverter by changing the overload current rating specifications according to load applications. Note that the control rating of each function changes.

Pr. No.	Name	Initial Value	Setting Range	Description	Parameters referred to	Refer to Section
570	Multiple rating setting	2	0 <sup>①</sup>	SLD Ambient temperature 40°C, Overload current rating 110% 60s, 120% 3s (Inverse time characteristics)	—	
			1 <sup>①</sup>	LD Ambient temperature 50°C, Overload current rating 120% 60s, 150% 3s (Inverse time characteristics)		
			2	ND Ambient temperature 50°C, Overload current rating 150% 60s, 200% 3s (Inverse time characteristics)		
			3	HD Ambient temperature 50°C, Overload current rating 200% 60s, 250% 3s (Inverse time characteristics)		

<sup>①</sup> This function is valid for V/f control only. This parameter can be set only when "9999" is set in Pr. 80, Pr. 81, Pr. 453, and Pr. 454.

The initial value and setting range of the following parameters are changed by performing all parameter clear and reset after changing this parameter setting.

Pr. No.	Name		Pr. 570				Refer to Page
			0	1	2 (initial value)	3	
9	Electronic thermal O/L relay	Initial Value	SLD rated current <sup>①</sup>	LD rated current <sup>①</sup>	ND rated current <sup>①</sup>	HD rated current <sup>①</sup>	6-212
22	Stall prevention operation level	Setting Range	0–400%	0–400%	0–400%	0–400%	6-80, 6-155
		Initial Value	110 %	120 %	150 %	200 %	
23	Stall prevention operation level compensation factor at double speed	Setting Range	0–150%/9999	0–200%/9999	0–200%/9999	0–200%/9999	6-155
		Initial Value	9999	9999	9999	9999	
48	Second stall prevention operation current	Setting Range	0–120%	0–150%	0–220%	0–280%	6-155
		Initial Value	110%	120%	150%	200%	
56	Current monitoring reference	Initial Value	SLD rated current <sup>①</sup>	LD rated current <sup>①</sup>	ND rated current <sup>①</sup>	HD rated current <sup>①</sup>	6-333
62	Reference value at acceleration	Setting Range	0–120%	0–150%	0–220%	0–280%	6-208
		Initial Value	9999	9999	9999	9999	
63	Reference value at deceleration	Setting Range	0–120%	0–150%	0–220%	0–280%	6-208
		Initial Value	9999	9999	9999	9999	
114	Third stall prevention operation current	Setting Range	0–120%	0–150%	0–220%	0–280%	6-155
		Initial Value	110%	120%	150%	200%	
148	Stall prevention level at 0V input	Setting Range	0–120%	0–150%	0–220%	0–280%	6-155
		Initial Value	110%	120%	150%	200%	
149	Stall prevention level at 10V input	Setting Range	0–120%	0–150%	0–220%	0–280%	6-155
		Initial Value	120%	150%	200%	250%	
150	Output current detection level	Setting Range	0–120%	0–150%	0–220%	0–280%	6-315
		Initial Value	110%	120%	150%	200%	
152	Zero current detection level	Setting Range	0–120%	0–150%	0–220%	0–280%	6-315
		Initial Value	5%	5%	5%	5%	

**Tab. 6-34:** Influence of Pr. 570 on other parameters (1)

Pr. No.	Name		Pr. 570				Refer to Page
			0	1	2 (initial value)	3	
165	Stall prevention operation level for restart	Setting Range	0–120%	0–150%	0–220%	0–280%	6-340
		Initial Value	110%	120%	150%	200%	
271	High-speed setting maximum current	Setting Range	0–120%	0–150%	0–220%	0–280%	6-512
		Initial Value	50%	50%	50%	50%	
272	Middle-speed setting minimum current	Setting Range	0–120%	0–150%	0–220%	0–280%	6-512
		Initial Value	100%	100%	100%	100%	
279	Brake opening current	Setting Range	0–220%	0–220%	0–220%	0–280%	6-264
		Initial Value	130%	130%	130%	130%	
557	Current average value monitor signal output reference current	Initial Value	SLD rated current <sup>①</sup>	LD rated current <sup>①</sup>	ND rated current <sup>①</sup>	HD rated current <sup>①</sup>	6-536
893	Energy saving monitor reference (motor capacity)	Initial Value	SLD value of applied motor capacity <sup>①</sup>	LD value of applied motor capacity <sup>①</sup>	ND value of applied motor capacity <sup>①</sup>	HD value of applied motor capacity <sup>①</sup>	6-363

**Tab. 6-34:** Influence of Pr. 570 on other parameters (2)

① The rated current differs according to the inverter capacity.

**NOTE**

When Pr. 570 = "0 or 1", Pr. 260 "PWM frequency automatic switchover" becomes valid. (Refer to section 6.19.1.)

**Precautions for the FR-A740-01800 or less and FR-A740-02160 or more**

If Pr. 570 is set to "0 (SLD) or 1 (LD)" when using FR-A740-01800, specifications of the inverter change to that of the FR-A740-02160. Setting change of Pr. 570 is made valid after all parameter clear and inverter reset.

Inverter	Multiple Rating Setting	Parameter Setting
FR-A740-01800	SLD	The inverter operates in the same manner as the FR-A740-02160 or more. Parameter setting range, minimum setting increments, initial values, etc. change to those of the 02160 or more. Refer to the parameter list for parameters whose values change.
	LD	
	ND	No change
	HD	
FR-A740-02160	SLD	No change
	LD	
	ND	
	HD	

**Tab. 6-35:** Influence of Pr. 570 on the inverter specifications

**Example** ▽

For example, when using the FR-A740-01800, setting "0" in Pr. 570 and performing inverter reset after all parameter clear will change the setting range of Pr. 9 from "0 to 500A" to "0 to 3600A" and the minimum setting increments from "0.01A" to "0.1A". (Refer to the parameter list for other parameters.)

△

## 6.8 Limit the output frequency

Purpose	Parameters that must be set		Refer to Section
Set upper limit and lower limit of output frequency	Maximum/minimum frequency	Pr. 1, Pr. 2, Pr. 18	6.8.1
Perform operation by avoiding machine resonance points	Frequency jump	Pr. 31–Pr. 46	6.8.2

### 6.8.1 Maximum and minimum frequency (Pr. 1, Pr. 2, Pr. 18)

You can limit the motor speed. Clamp the upper and lower limits of the output frequency.

Pr. No.	Name	Initial Value		Setting Range	Description	Parameters referred to	Refer to Section
1	Maximum frequency	01800 or less	120Hz	0–120Hz	Set the upper limit of the output frequency.	13 Starting frequency	6.11.2
		02160 or more	60Hz			15 Jog frequency	6.10.2
2	Minimum frequency	0Hz		0–120Hz	Set the lower limit of the output frequency.	125 Terminal 2 frequency setting gain frequency	6.20.5
						126 Terminal 4 frequency setting gain frequency	
18	High speed maximum frequency ①	01800 or less	120Hz	120–400Hz	Set when performing the operation at 120Hz or more		
		02160 or more	60Hz				

#### Set the maximum frequency

Set the upper limit of the output frequency in Pr. 1 "Maximum frequency". If the frequency of the frequency command entered is higher than the setting, the output frequency is clamped at the maximum frequency.

When you want to perform operation above 120Hz, set the upper limit of the output frequency to Pr. 18 "High speed maximum frequency". (When Pr. 18 is set, Pr. 1 automatically switches to the frequency of Pr. 18. When Pr. 18 is set, Pr. 18 automatically switches to the frequency of Pr. 1.)

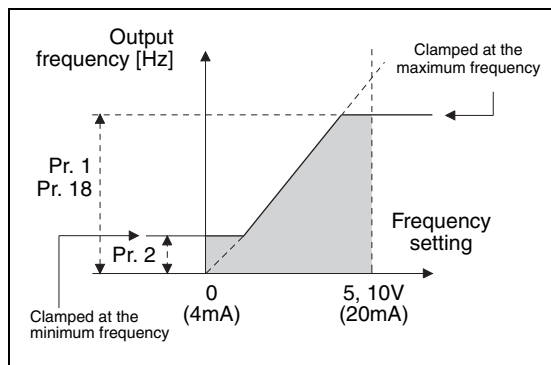

Fig. 6-56: Maximum und minimum output frequency

1001100E

#### NOTE

When performing operation above 50Hz using the frequency setting analog signal, change Pr. 125 (Pr. 126) "Frequency setting gain". (Refer to section 6.20.5.) If only Pr. 1 or Pr. 18 is changed, operation above 50Hz cannot be performed.



**Set the minimum frequency**

Use Pr. 2 "Minimum frequency" to set the lower limit of the output frequency. The output frequency is clamped by the Pr. 2 setting even the set frequency is lower than the Pr. 2 setting (The frequency will not decrease to the Pr. 2 setting.)

**NOTES**

When Pr. 15 "Jog frequency" is equal to or less than Pr. 2, the Pr. 15 setting has precedence over the Pr. 2 setting.

When stall prevention is activated to decrease the output frequency, the output frequency may drop to Pr. 2 or below.

**CAUTION:**

*If the Pr. 2 setting is higher than the Pr. 13 "Starting frequency" value, note that the motor will run at the set frequency according to the acceleration time setting by merely switching the start signal on, without entry of the command frequency.*

### 6.8.2 Avoid mechanical resonance points (Frequency jump) (Pr. 31 to Pr. 36)

When it is desired to avoid resonance attributable to the natural frequency of a mechanical system, these parameters allow resonant frequencies to be jumped.

Pr. No.	Name	Initial Value	Setting Range	Description
<b>31</b>	Frequency jump 1A	9999	0-400Hz/9999	1A to 1B, 2A to 2B, 3A to 3B is frequency jumps 9999: Function invalid
<b>32</b>	Frequency jump 1B	9999	0-400Hz/9999	
<b>33</b>	Frequency jump 2A	9999	0-400Hz/9999	
<b>34</b>	Frequency jump 2B	9999	0-400Hz/9999	
<b>35</b>	Frequency jump 3A	9999	0-400Hz/9999	
<b>36</b>	Frequency jump 3B	9999	0-400Hz/9999	

Parameters referred to	Refer to Section
—	

Up to three areas may be set, with the jump frequencies set to either the top or bottom point of each area.

The settings of frequency jumps 1A, 2A, 3A are jump points, and operation is performed at these frequencies in the jump areas.

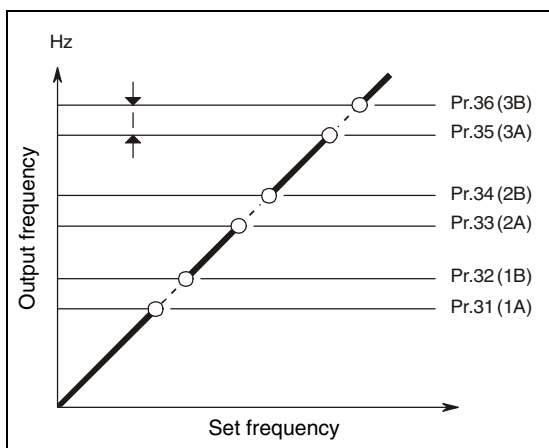

**Fig. 6-57:**  
Definition of the jump areas

1000019C

The following diagrams show how the jump point is selected. The diagram on the left shows a sequence in which the jump takes place at the end of the area to be jumped, for which the lower frequency must be entered in parameter 31 "Frequency jump 1A". In the diagram on the right the jump takes place at the beginning of the frequency area to be jumped, for which the higher frequency must be entered parameter 31 "Frequency jump 1A".

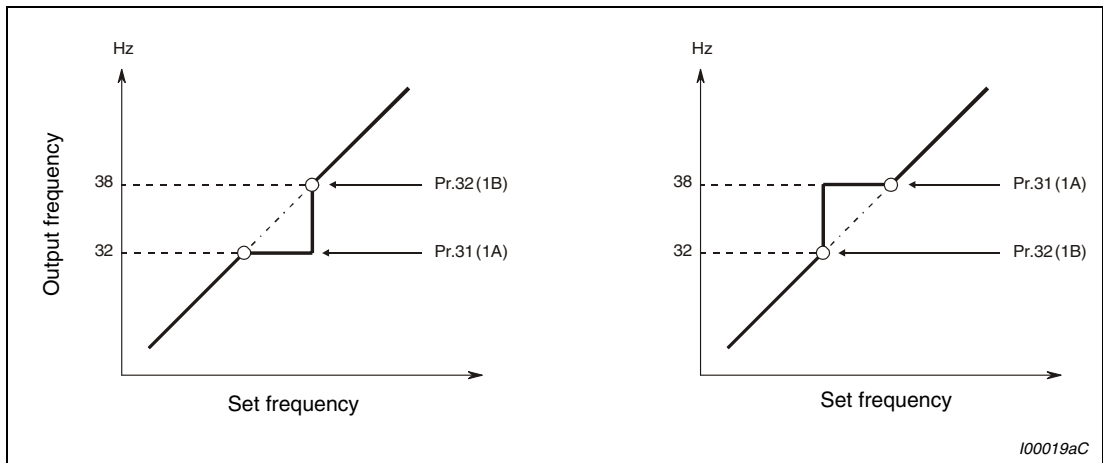

**Fig. 6-58:** Selection of the jump point

**NOTE**

During acceleration/deceleration, the running frequency within the set area is valid.

## 6.9 Set V/f pattern

Purpose	Parameters that must be set		Refer to Section
Set motor ratings	Base frequency, Base frequency voltage	Pr. 3, Pr. 19, Pr. 47, Pr. 113	6.9.1
Select a V/f pattern according to applications	Load pattern selection	Pr. 14	6.9.2
Automatically set a V/f pattern for elevators	Elevator mode (automatic acceleration/ deceleration)	Pr. 61, Pr. 64, Pr. 292	6.9.3
Use special motor	Adjustable 5 points V/f	Pr. 71, Pr. 100–Pr. 109	6.9.4

### 6.9.1 Base frequency, voltage (Pr. 3, Pr. 19, Pr. 47)

Used to adjust the inverter outputs (voltage, frequency) to the motor rating.

Pr. No.	Name	Initial Value	Setting Range	Description	Parameters referred to	Refer to Section
<b>3</b>	Base frequency	50Hz	0–400Hz	Set the frequency when the motor rated torque is generated. (50Hz/ 60Hz)	14 Load pattern selection	6.9.2
<b>19</b>	Base frequency voltage	8888	0–1000V	Set the rated motor voltage.	29 Acceleration/deceleration pattern selection	6.11.3
			8888	95% of power supply voltage	71 Applied motor selection	6.12.2
			9999	Same as power supply voltage	80 Motor capacity (simple magnetic flux vector control)	6.2.2
<b>47</b>	Second V/f (base frequency)	9999	0–400Hz	Set the base frequency when the RT signal is on.	83 Motor rated voltage	6.12.3
			9999	Second V/f invalid	84 Rated motor frequency	6.12.3
<b>113</b>	Third V/f (base frequency)	9999	0–400Hz	Set the base frequency when the X9 signal is ON.	178–189 Input terminal function selection	6.14.1
			9999	Third V/f is invalid	Advanced magnetic flux vector control Real sensorless vector control	6.7.2 6.2.2

**Setting of base frequency (Pr. 3)**

When operating a standard motor, generally set the rated frequency of the motor to Pr. 3 "Base frequency".

When running the motor using commercial power supply-inverter switch-over operation, set Pr. 3 to the same value as the power supply frequency.

If the frequency given on the motor rating plate is "60Hz" only, always set to "60Hz". It may result in an inverter trip due to overload. Caution must be taken especially when Pr. 14 "Loadpattern selection" = "1" (variable torque load).

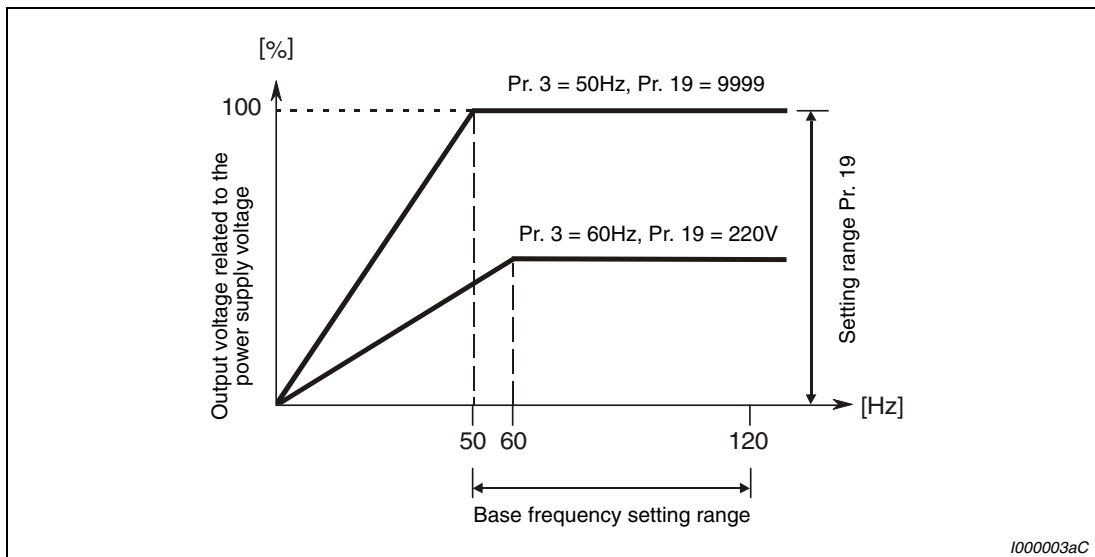

**Fig. 6-59:** Output voltage related to the output frequency

**Set multiple base frequencies (Pr. 47, Pr. 113)**

When you want to change the base frequency when switching two motors with one inverter, use the Pr. 47 "Second V/f (base frequency)".

Pr. 47 "Second V/f (base frequency)" is made valid when the RT signal in ON and Pr. 113 "Third V/f (base frequency)" is made valid when the X9 signal is on. Assign the terminal for X9 signal input using any of Pr. 178 to Pr. 189 "Input terminal function selection".

**NOTES**

The RT(X9) signal acts as the second (third) function selection signal and makes the other second (third) functions valid.

In the initial setting, the RT signal is assigned to the RT terminal. By setting "3" to any of Pr. 178 to Pr. 189 "Input terminal function selection", you can assign the RT signal to the other terminal.

**Base frequency voltage setting (Pr. 19)**

Use Pr. 19 "Base frequency voltage" to set the base voltage (e.g. rated motor voltage). If the setting is less than the power supply voltage, the maximum output voltage of the inverter is as set in Pr. 19.

Pr. 19 can be utilized in the following cases:

- When regeneration frequency is high (e.g. continuous regeneration)  
During regeneration, the output voltage becomes higher than the reference and may cause an over current trip (E.OC□) due to an increased motor current.
- When power supply voltage variation is large  
When the power supply voltage exceeds the rated voltage of the motor, speed variation or motor overheat may be caused by excessive torque or increased motor current.
- For special settings (87Hz function, special motors, field weakening range)  
Pr. 19 can also be set to a value above the power supply voltage when operating motors with special windings, in 87Hz mode or for field weakening operation with a specific output voltage. The inverter will then use a V/f pattern the rise of which is defined by Pr. 3 and Pr. 19. However, the actual effective output voltage cannot be higher than the power supply voltage and is thus limited to this maximum value.

**NOTES**

When operation is discontinued under vector control due to failure of an encoder, etc., setting "20" in Pr. 800 "Control method selection" enables V/f control operation.

When advanced magnetic flux vector control mode, real sensorless vector control or vector control is selected, Pr. 3, Pr. 47, Pr. 113 and Pr. 19 are made invalid and Pr. 83 and Pr. 84 are made valid.

Note that Pr. 3 or Pr. 47 and Pr. 113 values are made valid as inflection points of S-pattern when Pr. 29 "Acceleration/deceleration pattern selection" = 1 (S-pattern acceleration/deceleration A).

When Pr. 71 "Applied motor" is set to 2 (adjustable 5 points V/f characteristic), the Pr. 47 and Pr. 113 setting becomes invalid. In addition, you cannot set "8888" or "9999" in Pr. 19.

Changing the terminal assignment using Pr. 178 to Pr. 189 "Input terminal function selection" may affect the other functions. Make setting after confirming the function of each terminal.

Note that the output voltage of the inverter cannot exceed the power supply voltage.

### 6.9.2 Load pattern selection (Pr. 14) V/F

You can select the optimum output characteristic (V/f characteristic) for the application and load characteristics.

Pr. No.	Name	Initial Value	Setting Range	Description	Parameters referred to	Refer to Section
14	Load pattern selection	0	0	For constant torque load	0 Torque boost 3 Base frequency 178-189 Input terminal function selection Advanced magnetic flux vector control Real sensorless vector control	6.7.1 6.9.1 6.14.1 6.7.2 6.2.2
			1	Quadratisches Lastmoment		
			2	For constant torque elevators (at reverse rotation boost of 0%)		
			3	For constant torque elevators (at forward rotation boost of 0%)		
			4	RT signal on ... for constant torque load RT signal off ... for constant torque elevators at reverse rotation boost of 0%		
			5	RT signal on ... for constant torque load RT signal off ... for constant torque elevators at forward rotation boost of 0%		

#### For constant-torque load (Pr. 14 = 0, initial value)

At or less than the base frequency voltage, the output voltage varies linearly with the output frequency. Set this value when driving the load whose load torque is constant even if the speed varies, e.g. conveyor, cart or roll drive.

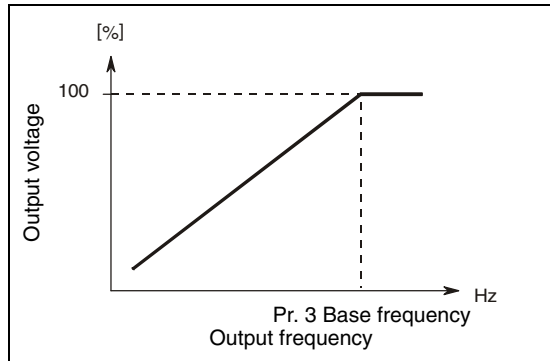
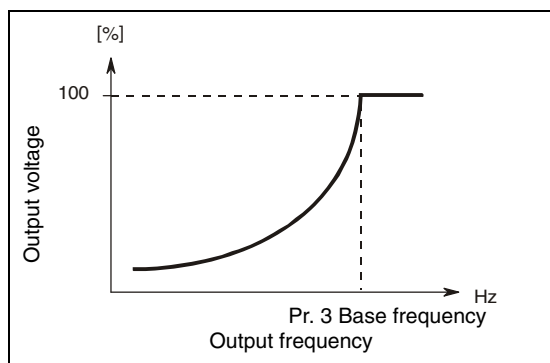

**Fig. 6-60:**  
Constant-torque load

1001322C

#### For variable-torque load (Pr. 14 = 1)

At or less than the base frequency voltage, the output voltage varies with the output frequency in a square curve. Set this value when driving the load whose load torque varies in proportion to the square of the speed, e.g. fan or pump.



**Fig. 6-61:**  
Variable-torque load

1001323C

### Vertical lift load applications (setting values 2 or 3)

Set "2" when a vertical lift load is fixed as power driving load at forward rotation and regenerative load at reverse rotation.

Pr. 0 "Torque boost" is valid during forward rotation and torque boost is automatically changed to "0%" during reverse rotation.

Set "3" for an elevated load that is in the driving mode during reverse rotation and in the regenerative load mode during forward rotation according to the load weight, e.g. counterweight system.

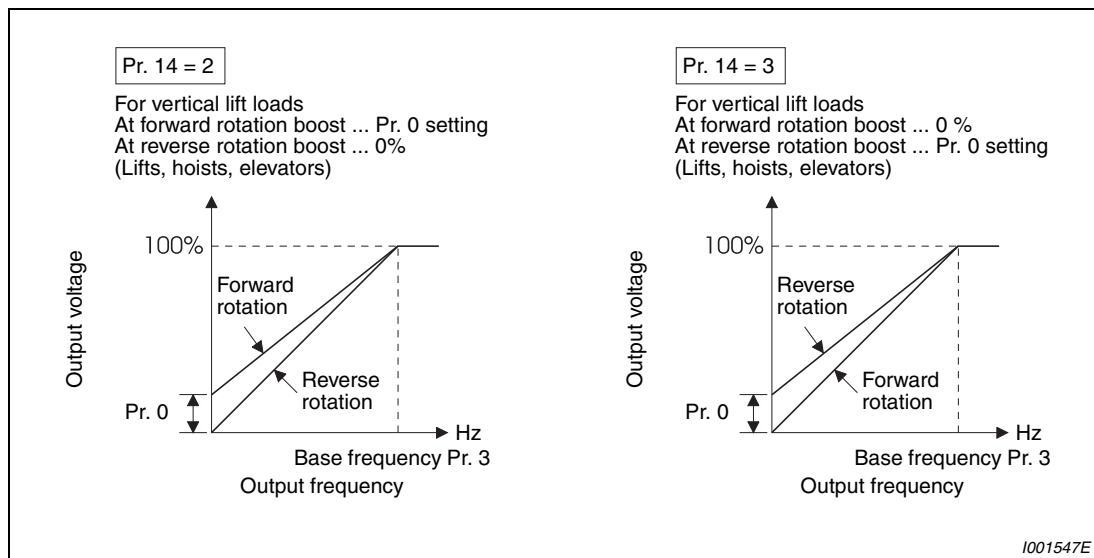

**Fig. 6-62:** Characteristic with manual torque boost

#### NOTE

When torque is continuously regenerated as vertical lift load, it is effective to set the rated voltage in Pr. 19 "Base frequency voltage" to prevent trip due to current at regeneration.



**Change load pattern selection using terminal (Pr. 14 = 4 or 5)**

Output characteristic can be switched between for constant torque load and for elevator using the RT signal or X17 signal. For the terminal used for X17 signal input, set "17" in any of Pr. 178 to Pr. 189 "Input terminal function selection" to assign the function. When X17 is assigned, switchover by the RT signal is made invalid.

Pr. 14	RT (X17) Signal	Output Characteristics
4	EIN	For constant torque load (same as when the setting is "0")
	AUS	For elevators at reverse rotation boost of 0% (same as when the setting is "2")
5	EIN	For constant torque load (same as when the setting is "0")
	AUS	For elevators at forward rotation boost of 0% (same as when the setting is "3")

**Tab. 6-36:** Change load pattern selection using terminal

**NOTE**

The RT signal is assigned to the terminal RT in the initial setting. By setting "3" in any of Pr. 178 to Pr. 189 "Input terminal function selection", the RT signal can be assigned to the other terminal.

When advanced magnetic flux vector control, real sensorless vector control or vector control is selected, this parameter setting is ignored.

Changing the terminal assignment using Pr. 178 to Pr. 189 (input terminal function selection) may affect the other functions. Make setting after confirming the function of each terminal.

When the RT signal is on, the other second functions are also valid.

### 6.9.3 Elevator mode (automatic acceleration/deceleration) (Pr. 61, Pr. 64, Pr. 292)

Operation matching a load characteristic of elevator with counterweight can be performed.

Pr. No.	Name	Initial Value	Setting Range	Description	Parameters referred to	Refer to Section	
61	Reference current	9999	01800 or less	0-500A	Set the reference current for elevator mode.	570 Multiple rating setting	6.7.5
			02160 or more	0-3600A			
			9999	Rated inverter current value reference			
64	Starting frequency for elevator mode	9999	0-10%	Set the starting frequency for the elevator mode.			
			9999	Starting frequency 2Hz			
292	Automatic acceleration/deceleration	0	0	Normal mode	Refer to section 6.11.4		
			1	Minimum acceleration/deceleration (without brake)			
			11	Minimum acceleration/deceleration (with brake)			
			3	Optimum acceleration/deceleration			
			5	Elevator mode 1 (stall prevention operation level 150%)			
			6	Elevator mode 2 (stall prevention operation level 180%)			
			7/8	Brake sequence mode 1, 2 (Refer to section 6.13.5)			

#### Elevator mode

- When "5" or "6" is set in Pr. 292 "Automatic acceleration/deceleration", elevator mode is selected and each setting is changed as in the table below.
- Enough torque is generated during power driving and the torque boost value is automatically changed during regeneration and operation without load (refer to Fig. 6-63) so that overcurrent protection function does not activate due to over excitation.

	Normal Mode	Elevator Mode	
		Pr. 292 = 5	Pr. 292 = 6
Torque boost	Pr. 0 (6/4/3/2%)	Changes according to the output current (right chart)	
Starting frequency	Pr. 13 (0.5Hz)	Pr. 64 (2Hz) Accelerate after maintaining 100ms	
Base frequency voltage	Pr. 19 (8888)	440V	
Stall prevention operation level	Pr. 22 (150%) etc.	150%	180%

**Tab. 6-37:** Valid values in the elevator mode

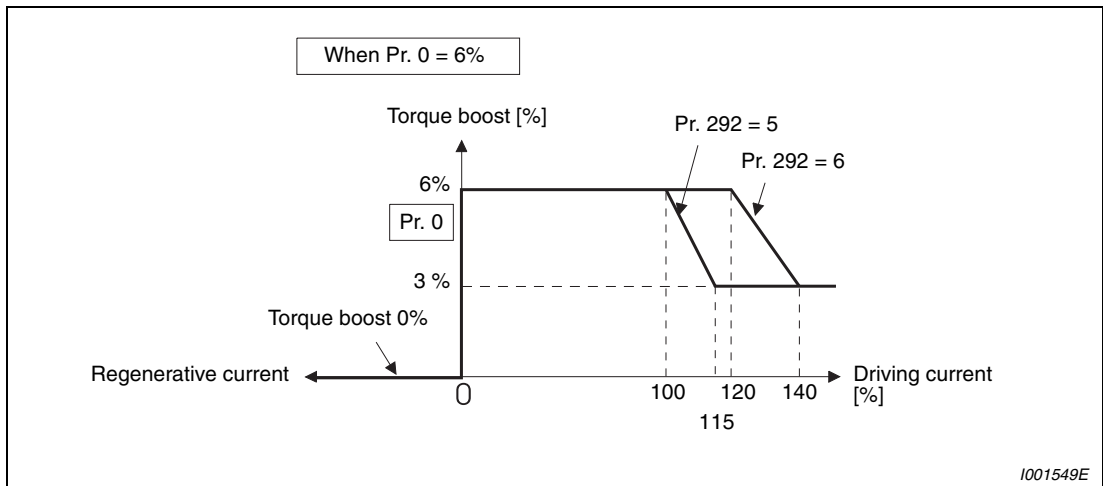

**Fig. 6-63:** Torque boost in dependence of the output current

- When operating the elevator with load more than the rated inverter current, the maximum torque may become insufficient. For the elevator without counterweight, setting "2 or 3" (for elevator load) in Pr. 14 "Load pattern selection" and an appropriate value in Pr. 19 "Base frequency voltage" will generate larger maximum torque than when elevator mode is selected.

**NOTE**

Stall prevention operation level automatically decreases according to the electronic thermal relay function cumulative value, to prevent inverter overload shut-off (E.THT, E.THM).

When elevator mode (Pr. 292 = 5, 6) is set with automatic acceleration / deceleration set, the stall prevention operation level is changed as shown below.

		Overload Capacity			
		120%	150%	200%	250%
		Pr. 570 = 0	Pr. 570 = 1	Pr. 570 = 2	Pr. 570 = 3
Stall prevention operation level	Pr. 292 = 5	110%	120%	150%	200%
	Pr. 292 = 6	115%	140%	180%	230%

**Tab. 6-38:** Influence of the overload capacity on the current limit

**Adjustment of elevator mode (Pr. 61, Pr. 64)**

By setting the adjustment parameters Pr. 61 and Pr. 64, the application range can be made wider.

Pr. No.	Name	Setting Range		Description
61	Reference current	01800 or less	0–50A	For example, when the motor and inverter are different in capacity, set the rated motor current value. Set reference current (A) of the stall prevention operation level
		01800 or more	0–3600A	
		9999 (initial value)		The rated inverter output current is defined as reference.
64	Starting frequency for elevator mode	0–10Hz		Set the starting frequency for the elevator mode.
		9999 (initial value)		Starting frequency 2Hz

**Tab. 6-39:** Adjustment of elevator mode

**NOTES**

Even if automatic acceleration/deceleration has been selected, inputting the jog signal (jog operation), RT signal (second function selection) or X9 signal (third function selection) during an inverter stop will switch to the normal operation and give priority to jog operation or second and third function selection. Note that JOG and RT signal input is invalid even if JOG signal and RT signal are input during operation with acceleration/deceleration selected.

Elevator mode is invalid when advanced magnetic flux vector, real sensorless vector control or vector control is selected.

Since the Pr. 61 and Pr. 64 settings automatically return to the initial value (9999) if the Pr. 292 setting is changed, set Pr. 292 first when you need to set Pr. 61 and Pr. 64.

### 6.9.4 Adjustable 5 points V/f (Pr. 71, Pr. 100 bis Pr. 109) V/F

A dedicated V/f pattern can be made by freely setting the V/f characteristic between a start-up and the base frequency and base voltage under V/f control (frequency voltage/frequency). The torque pattern that is optimum for the machine's characteristic can be set.

Pr. No.	Name	Initial Value	Setting Range	Description	Parameters referred to	Refer to Section
<b>71</b>	Applied motor	0	0-8/13-18/ 20/23/24/30/ 33/34/40/43/ 44/50/53/54	Set "2" for adjustable 5 points V/f control.	3 Base frequency 19 Base frequency voltage	6.9.1 6.9.1
<b>100</b>	V/f1 (first frequency)	9999	0-400Hz/9999	Set each points (frequency, voltage) of V/f pattern. 9999: No V/f setting	12 DC injection brake operation voltage	6.13.1
<b>101</b>	V/f1 (first frequency voltage)	0V	0-1000V/9999		113 Third V/f (base frequency)	6.9.1
<b>102</b>	V/f2 (second frequency)	9999	0-400Hz/9999		47 Second V/f (base frequency)	6.9.1
<b>103</b>	V/f2 (second frequency voltage)	0V	0-1000V/9999		60 Energy saving control selection	6.18.1
<b>104</b>	V/f3 (third frequency)	9999	0-400Hz/9999		71 Applied motor Advanced magnetic flux vector control	6.12.2 6.2.2
<b>105</b>	V/f3 (third frequency voltage)	0V	0-1000V/9999		Real sensorless vector control	6.2.2
<b>106</b>	V/f4 (fourth frequency)	9999	0-400Hz/9999			
<b>107</b>	V/f4 (fourth frequency voltage)	0V	0-1000V/9999			
<b>108</b>	V/f5 (fifth frequency)	9999	0-400Hz/9999			
<b>109</b>	V/f5 (fifth frequency voltage)	0V	0-1000V/9999			

Any V/f characteristic can be provided by presetting the parameters of V/f1 (first frequency voltage/first frequency) to V/f5.

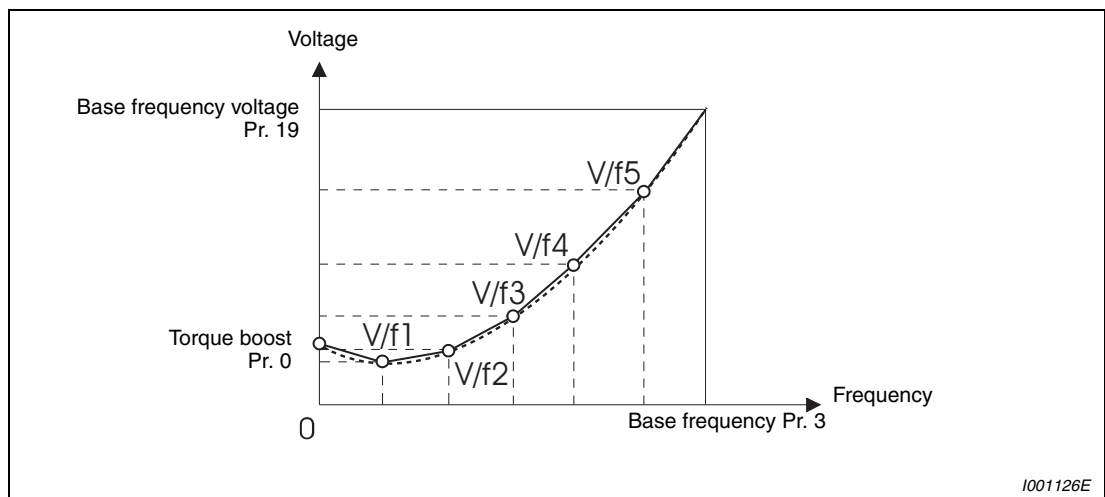

**Fig. 6-64:** V/f characteristic

For a machine of large static friction coefficient and small dynamic static friction coefficient, for example, set a V/f pattern that will increase the voltage only in a low-speed range since such a machine requires large torque at a start.

**CAUTION:**

***Set this parameter correctly according to the motor used. Incorrect setting may cause the motor to overheat and burn.***

Setting procedure:

- ① Set the rated motor current in Pr. 19 "Base frequency voltage". (No function at the setting of "9999" (initial value) or "8888".)
- ② Set Pr. 71 "Applied motor" to "2" (Adjustable 5 points V/f characteristic).
- ③ Set the frequency and voltage you want to set in Pr. 100 to Pr. 109

**NOTES**

Adjustable 5 points V/f characteristics function only under V/f control. They do not function under advanced magnetic flux vector control, real sensorless vector control or vector control.

When Pr. 19 "Base frequency voltage" = 8888 or 9999, Pr. 71 cannot be set to "2". To set Pr. 71 to "2", set the rated voltage value in Pr. 19.

When the frequency values at each point are the same, a write disable error "Er1" appears.

Set the points (frequencies, voltages) of Pr. 100 to Pr. 109 within the ranges of Pr. 3 "Base frequency" and Pr. 19 "Base frequency voltage".

When "2" is set in Pr. 71, Pr. 47 "Second V/f (base frequency)" and Pr. 113 "Third V/f (base frequency)" will not function.

When Pr. 71 is set to "2", the electronic thermal relay function makes calculation as a standard motor.

A greater energy saving effect can be expected by combining Pr. 60 "Energy saving control selection" and adjustable 5 points V/f.

For the 00170 and 00250, the Pr. 0 and Pr. 12 settings are automatically changed according to the Pr. 71 setting:

**Parameter 71 = 0, 2, 3–8, 20, 23, 24, 40, 43, 44**

The setting of Parameter 0 changes to 3% and the setting of Parameter 12 to 4%.

**Parameter 71 = 1, 13–18, 50, 53, 54**

The settings of Parameter 0 and 12 change to 2%.

## 6.10 Frequency setting by external terminals

Purpose	Parameters that must be set		Refer to Section
Make frequency setting by combination of terminals	Multi-speed operation	Pr. 4–Pr. 6, Pr. 24–Pr. 27 Pr. 232–Pr. 239	6.10.1
Perform jog operation	Jog operation	Pr. 15, Pr. 16	6.10.2
Added compensation for multi-speed setting and remote setting	Multi-speed input compensation selection	Pr. 28	6.10.3
Infinitely variable speed setting by terminals	Remote setting function	Pr. 59	6.10.4

### 6.10.1 Multi-speed setting operation

Can be used to change the preset speed in the parameter with the contact signals.

Any speed can be selected by merely turning on-off the contact signals (RH, RM, RL, REX signals).

Pr. No.	Name	Initial Value	Setting Range	Description	Parameters referred to	Refer to Section
<b>4</b>	Multi-speed setting (high speed)	50Hz	0–400Hz	Set the frequency when RH turns on.	15 JOG frequency	6.10.2
<b>5</b>	Multi-speed setting (middle speed)	30Hz	0–400Hz	Set the frequency when RM turns on.	28 Multi-speed input compensation selection	6.10.3
<b>6</b>	Multi-speed setting (low speed)	10Hz	0–400Hz	Set the frequency when RL turns on.	59 Remote function selection	6.10.4
<b>24</b>	Multi-speed setting (speed 4) ①	9999	0–400Hz/9999	Frequency from speed 4 to speed 15 can be set according to the combination of the RH, RM, RL and REX signals. 9999: not selected	79 Operation mode selection	6.22.1
<b>25</b>	Multi-speed setting (speed 5) ①	9999	0–400Hz/9999		178–189 Input terminal function selection	6.14.1
<b>26</b>	Multi-speed setting (speed 6) ①	9999	0–400Hz/9999			
<b>27</b>	Multi-speed setting (speed 7) ①	9999	0–400Hz/9999			
<b>232</b>	Multi-speed setting (speed 8) ①	9999	0–400Hz/9999			
<b>233</b>	Multi-speed setting (speed 9) ①	9999	0–400Hz/9999			
<b>234</b>	Multi-speed setting (speed 10) ①	9999	0–400Hz/9999			
<b>235</b>	Multi-speed setting (speed 11) ①	9999	0–400Hz/9999			
<b>236</b>	Multi-speed setting (speed 12) ①	9999	0–400Hz/9999			
<b>237</b>	Multi-speed setting (speed 13) ①	9999	0–400Hz/9999			
<b>238</b>	Multi-speed setting (speed 14) ①	9999	0–400Hz/9999			
<b>239</b>	Multi-speed setting (speed 15) ①	9999	0–400Hz/9999			

#### NOTE

The above parameters allow its setting to be changed during operation in any operation mode even if "0" (initial value) is set in Pr. 77 "Parameter write selection".

Operation is performed at the frequency set in Pr. 4 when the RH signal turns on, Pr. 5 when the RM signal turns on, and Pr. 6 when the RL signal turns on.

Frequency from speed 4 to speed 15 can be set according to the combination of the RH, RM, RL and REX signals. Set the running frequencies in Pr. 24 to Pr. 27, Pr. 232 to Pr. 239. (In the initial value setting, speed 4 to speed 15 are unavailable.)

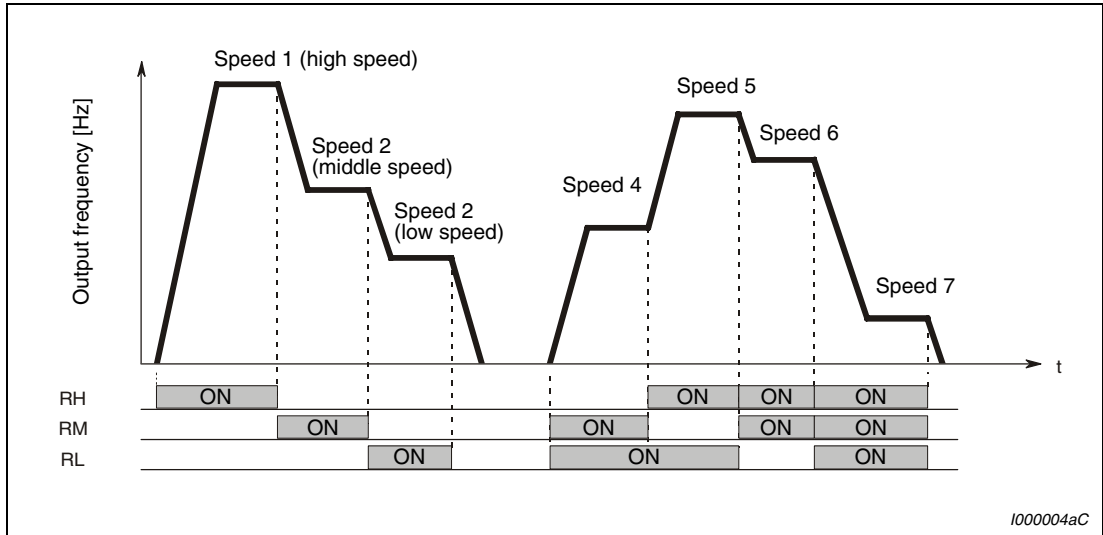

**Fig. 6-65:** Multi-speed selection by external terminals

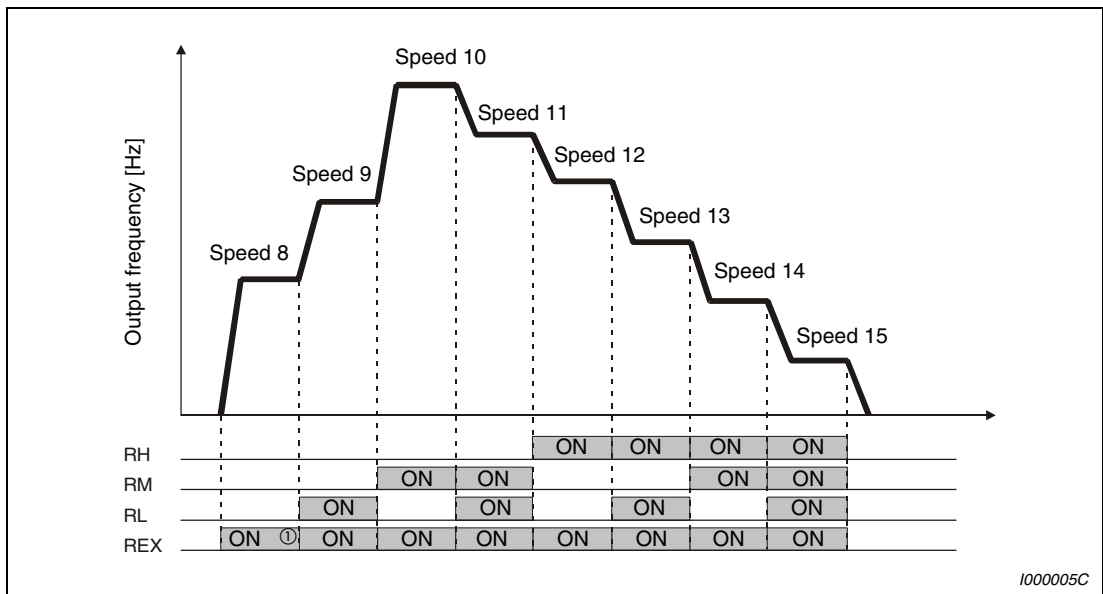

**Fig. 6-66:** Multi-speed selection by external terminals

① When "9999" is set in Pr. 232 "Multi-speed setting (speed 8)", operation is performed at frequency set in Pr. 6 when RH, RM and RL are turned off and REX is turned on.

**NOTES**

In the initial setting, if two or three speeds are simultaneously selected, priority is given to the set frequency of the lower signal. For example, when the RH and RM signals turn on, the RM signal (Pr. 5) has a higher priority.

The RH, RM, RL signals are assigned to the terminal RH, RM, RL in the initial setting. By setting "0 (RL)", "1 (RM)", "2 (RH)" in any of Pr. 178 to Pr. 189 "Input terminal function assignment", you can assign the signals to other terminals.

For the terminal used for REX signal input, set "8" in any of Pr. 178 to Pr. 186 to assign the function.



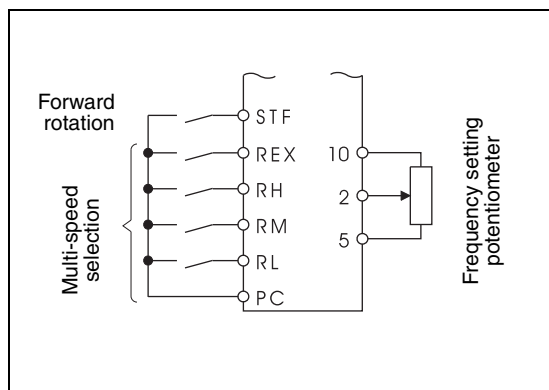

**Fig. 6-67:**  
Connection example

I001127E

## NOTES

The priorities of the frequency commands by the external signals are "jog operation > multi-speed operation > terminal 4 analog input > terminal 2 analog input". (Refer to section 6.20 for the frequency command by analog input.)

Valid in external operation mode or PU/external combined operation mode (Pr. 79 = 3 or 4).

Multi-speed parameters can also be set in the PU or external operation mode.

Pr. 24 to Pr. 27 and Pr. 232 to Pr. 239 settings have no priority between them.

When a value other than "0" is set in Pr. 59 "Remote function selection", the RH, RM and RL signals are used as the remote setting signals and the multi-speed setting becomes invalid.

When making analog input compensation, set "1" in Pr. 28 "Multi-speed input compensation selection".

The RH, RM, RL, REX signals can be assigned to the input terminal using any of Pr. 178 to Pr. 189 "Input terminal function selection". When terminal assignment is changed, the other functions may be affected. Please make setting after confirming the function of each terminal.

### 6.10.2 Jog operation (Pr. 15, Pr. 16)

You can set the frequency and acceleration/deceleration time for jog operation. Jog operation can be performed from either the outside or PU.  
Can be used for conveyor positioning, test operation, etc.

Pr. No.	Name	Initial Value	Setting Range	Description	Parameters referred to	Refer to Section
<b>15</b>	Jog frequency	5Hz	0–400Hz	Set the frequency for jog operation.	13 Starting frequency	6.11.2
<b>16</b>	Jog acceleration/ deceleration time	0.5s	0–3600/360s ①	Acceleration/deceleration time for jog operation.  This setting is related to the reference frequency set in Pr. 20 and the increments set in Pr. 21. Pr. 21 = 0 (Initial setting) Setting range: 0–3600s Increments: 0.1s Pr. 21 = 1 Setting range: 0–360 s Increments: 0.01s The acceleration and deceleration times cannot be set separately.	29 Acceleration/deceleration pattern selection 20 Acceleration/deceleration reference frequency 21 Acceleration/ deceleration time increments 79 Operation mode selection 178–189 Input terminal function selection	6.11.3 6.11.1 6.11.1 6.22.1 6.14.1

The above parameters are displayed as simple mode parameters only when the parameter unit (FR-PU04) is connected. When the operation panel (FR-DU07) is connected, the above parameters can be set only when Pr. 160 "User group read selection" = 0.

#### Jog operation from outside

When the jog signal is on, a start and stop can be made by the start signal (STF, STR). (The jog signal is assigned to the terminal JOG in the initial setting.)

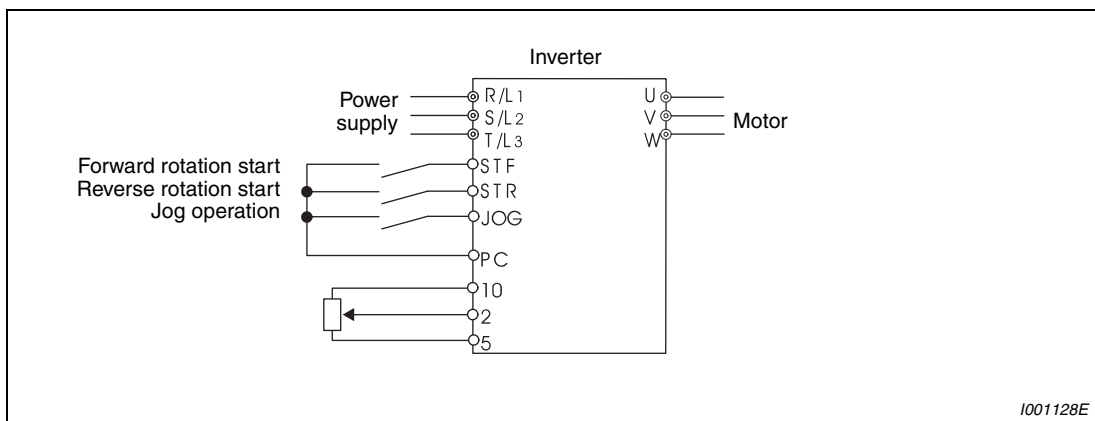
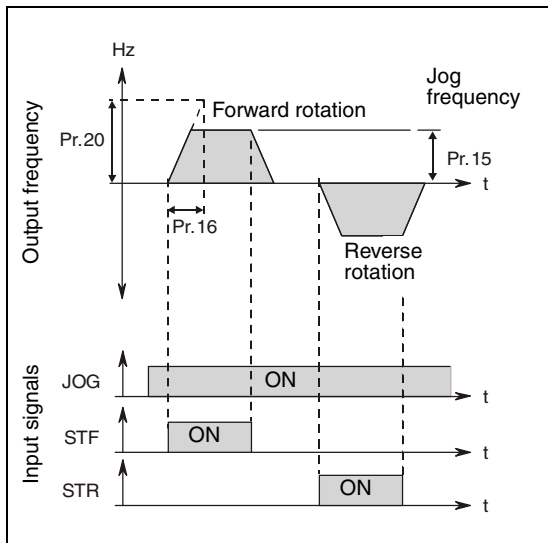
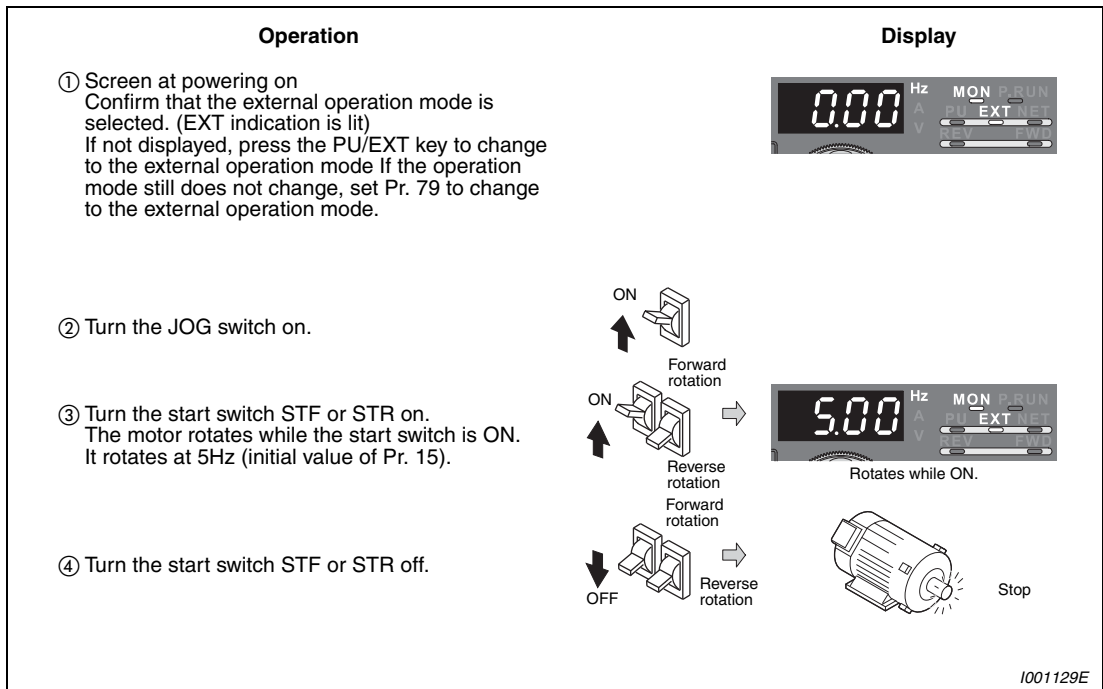

Fig. 6-68: Connection diagram for external jog operation



**Fig. 6-69:**  
Jog operation signal timing chart

I001324C

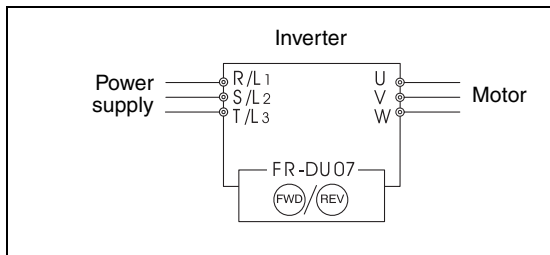

**Fig. 6-70:** Jog operation in the external operation mode

I001129E

### JOG operation from PU

Set the PU (FR-DU07/FR-PU04/FR-PU07) to the jog operation mode. Operation is performed only while the start button is pressed.



**Fig. 6-71:**  
Connection example for jog operation performed from PU

I001130E

Operation	Display
① Confirmation of the RUN indication and operation mode indication. The monitor mode must have been selected. The inverter must be at a stop.	
② Press the PU/EXT key to choose the PU JOG operation mode.	
③ Press the FWD or REV key. The motor rotates while the key is pressed. It rotates at 5Hz (initial value of Pr. 15).	
④ Release the FWD or REV key to stop the motor.	
When changing the frequency of PU JOG operation:	
⑤ Press the MODE key to choose the parameter setting mode.	
⑥ Turn the digital dial until Pr. 15 "JOG frequency" appears.	
⑦ Press the SET key to show the currently set value (5Hz).	
⑧ Turn the digital dial to set the value to "10.00" (10.00Hz).	
⑨ Press the SET key to set.	
⑩ Perform the operations in steps ① to ④ The motor rotates at 10Hz.	

I001131E

**Fig. 6-72:** JOG operation performed from PU

**NOTES**

When Pr. 29 "Acceleration/deceleration pattern selection" = "1" (S-pattern acceleration/deceleration A), the acceleration/deceleration time is the period of time required to reach Pr. 3 "Base frequency".

The Pr. 15 setting should be equal to or higher than the Pr. 13 "Starting frequency setting".

The JOG signal can be assigned to the input terminal using any of Pr. 178 to Pr. 189 "Input terminal function selection". When terminal assignment is changed, the other functions may be affected. Please make setting after confirming the function of each terminal.

During jog operation, the second acceleration/deceleration via the RT signal cannot be selected. (The other second functions are valid (refer to section 6.14.3)).

When Pr. 79 "Operation mode selection" = 4, push the FWD/REV key of the PU (FR-DU07/FR-PU04/FR-PU07) to make a start or push the STOP/RESET key to make a stop.

This function is invalid when Pr. 79 = 3 or 6.

Jog operation is invalid under position control.

### 6.10.3 Input compensation of multi-speed and remote setting (Pr. 28)

By inputting the frequency setting compensation signal (terminal 1, 2), the speed (frequency) can be compensated for relative to the multi-speed setting or the speed setting by remote setting function.

Pr. No.	Name	Initial Value	Setting Range	Description
28	Multi-speed input compensation selection	0	0	Without compensation
			1	With compensation

Parameters referred to	Refer to Section
4-6 Multi-speed operation 24-27 232-239	6.10.1
73 Analog input selection	6.20.2
59 Remote function selection	6.10.4
868 Terminal 1 function assignment	6.20.1

#### NOTES

Select the compensation input voltage (0 to  $\pm 5V$ , 0 to  $\pm 10$ ) and used terminal (terminal 1, 2) using Pr. 73 "Analog input selection".

When using terminal 1 for compensation input, set "0" (initial value) in Pr. 868 "Terminal 1 function assignment".

### 6.10.4 Remote setting function (Pr. 59)

Even if the operation panel is located away from the enclosure, you can use contact signals to perform continuous variable-speed operation, without using analog signals.

Pr. No.	Name	Initial Value	Setting Range	Description		Parameters referred to	Refer to Section
				RH, RM and RL signal function	Frequency setting storage function		
<b>59</b>	Remote function selection	0	0	Multi-speed setting	—	1 Maximum frequency	6.8.1
			1	Remote setting	✓	18 High speed maximum frequency	6.8.1
			2	Remote setting	—	7 Acceleration time	6.11.1
			3	Remote setting	(Turning STF/STR off clears remote setting frequency.)	8 Deceleration time	6.11.1
						44 Second acceleration/deceleration time	6.11.1
						45 Second deceleration time	6.11.1
						28 Multi-speed input compensation selection	6.10.3
						178-189 Input terminal function selection	6.14.1

Pr. 59 can be used to select a digital motor potentiometer. Setting Pr. 59 to a value of "1" activates the frequency setting storage function, so that the stored value is also stored when the power is switched off. The last frequency value is stored in the EEPROM. The delete instruction only applies to the data stored in RAM.

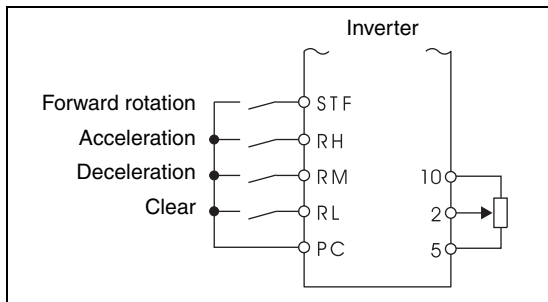

**Fig. 6-73:**  
Connection diagram for remote setting

I001132E

When Pr. 59 is set to any of "1 to 3" (remote setting function valid), the functions of the RH, RM and RL signals are changed: RH ⇒ acceleration, RM ⇒ deceleration and RL ⇒ clear.

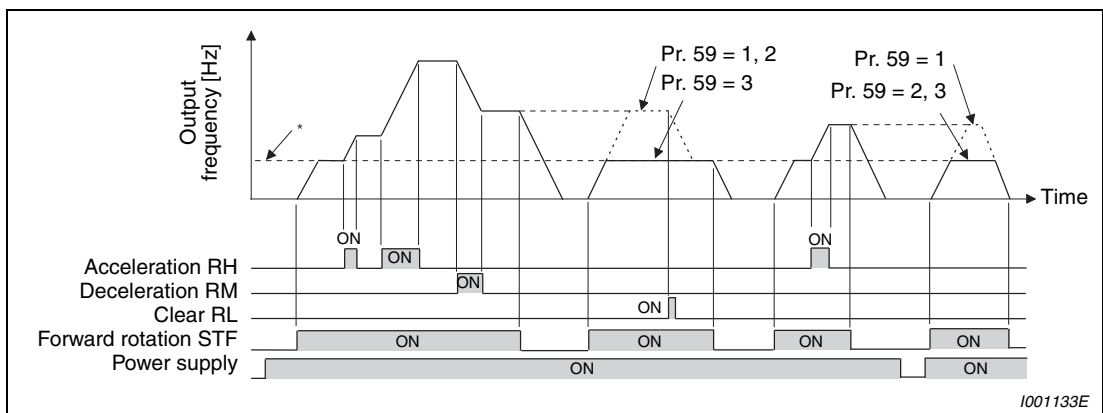

I001133E

**Fig. 6-74:** Example of the remote setting function

\* External operation frequency (other than multi-speed) or PU running frequency.

**Remote setting function**

When the remote function is used, the output frequency of the inverter can be compensated for as follows:

External operation: Frequency set by RH/RM operation + external running frequency or PU running frequency (other than multi-speed).

(When making analog input compensation, set "1" to Pr. 28 "Multi-speed input compensation selection".

When Pr. 28 is set to "0" and acceleration/deceleration is made to reach the set frequency of the analog voltage input (terminal 2 or terminal 4) by RH/RM, the auxiliary input by terminal 1 becomes invalid.)

PU operation: Frequency set by RH/RM operation + PU running frequency

**Frequency setting storage**

The frequency setting storage function stores the remote setting frequency (frequency set by RH/RM operation) into the memory (EEPROM). When power is switched off once, then on, operation is resumed with that output frequency value. (Pr. 59 =1)

The frequency is stored at the point when the start signal (STF or STR) turns off or every one minute after one minute has elapsed since turn off (on) of both the RH (acceleration) and RM (deceleration) signals. (The frequency is written if the present frequency setting compared with the past frequency setting every one minute is different. The state of the RL signal does not affect writing.)



**NOTES**

The range of frequency changeable by RH (acceleration) and RM (deceleration) is 0 to maximum frequency (Pr. 1 or Pr. 18 setting). Note that the maximum value of set frequency is (main speed + maximum frequency).

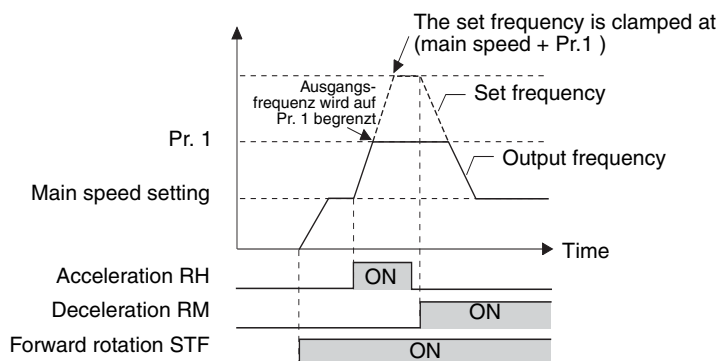

When the acceleration or deceleration signal switches on, acceleration/deceleration time is as set in Pr. 44 "Second acceleration/deceleration time" and Pr. 45 "Second deceleration time". Note that when long time has been set in Pr. 7 or Pr. 8, the acceleration/deceleration time is as set in Pr. 7 or Pr. 8. (when RT signal is off)

When the RT signal is on, acceleration/deceleration is made in the time set to Pr. 44 and Pr. 45, regardless of the Pr. 7 or Pr. 8 setting.

Even if the start signal (STF or STR) is off, turning on the acceleration (RH) or deceleration (RM) signal varies the preset frequency.

When switching the start signal from ON to OFF, or changing frequency by the RH or RM signal frequently, set the frequency setting value storage function (write to EEPROM) invalid (Pr. 59 = 2 or 3). If set valid (Pr. 59 = 1), frequency is written to EEPROM frequently, this will shorten the life of the EEPROM.

The RH, RM, RL signals can be assigned to the input terminal using any Pr. 178 to Pr. 189 "Input terminal function selection". When terminal assignment is changed, the other functions may be affected. Please make setting after confirming the function of each terminal.

Also available for the network operation mode.

During jog operation or PID control operation, the remote setting function is invalid.

**Set frequency = 0 Hz**

- Even when the remotely-set frequency is cleared by turning on the RL (clear) signal after turn off (on) of both the RH and RM signals, the inverter operates at the remotely-set frequency stored in the last operation if power is reapplied before one minute has elapsed since turn off (on) of both the RH and RM signals.

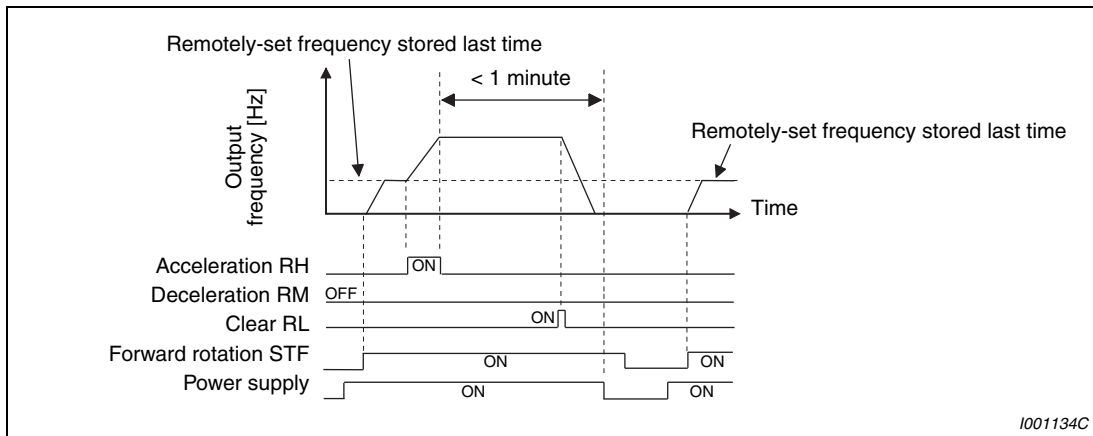

**Fig. 6-75: Outputting the remotely-set frequency stored last time**

- When the remotely-set frequency is cleared by turning on the RL (clear) signal after turn off (on) of both the RH and RM signals, the inverter operates at the frequency in the remotely-set frequency cleared state if power is reapplied after one minute has elapsed since turn off (on) of both the RH and RM signals.

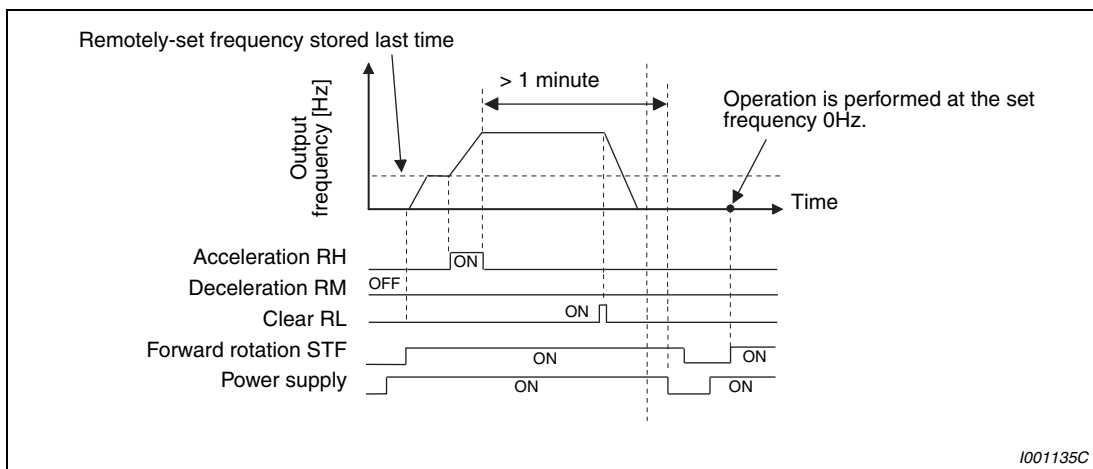

**Fig. 6-76: Outputting the current set frequency**



**CAUTION:**  
 When Pr. 59 is set to "1" the motor will restart automatically after a power failure if there is an active rotation direction signal.

## 6.11 Acceleration and deceleration

Purpose	Parameters that must be set	Refer to Section
Motor acceleration/deceleration time setting	Acceleration/deceleration times	Pr. 7, Pr. 8, Pr. 20, Pr. 21, Pr. 44, Pr. 45, Pr. 110, Pr. 111
Starting frequency	Starting frequency and start-time hold	Pr. 13, Pr. 571
Set acceleration/deceleration pattern suitable for application	Acceleration/deceleration pattern and back lash measures	Pr. 29, Pr. 140–Pr. 143 Pr. 380–Pr. 383 Pr. 516–Pr. 519
Automatically set appropriate acceleration/deceleration time	Automatic acceleration/deceleration	Pr. 61–Pr. 63 Pr. 292

### 6.11.1 Acceleration and deceleration time

Used to set motor acceleration/deceleration time.

Set a larger value for a slower speed increase/decrease or a smaller value for a faster speed increase/decrease.

Pr. No.	Name	Initial Value	Setting Range	Description	Parameters referred to	Refer to Section	
7	Acceleration time	00250 or less	5s	0–3600s/ 0–360s ①	Set the motor acceleration time.	3 Base frequency 10 DC injection brake (operation frequency)	6.9.1 6.13.1
		00310 or more	15s				
8	Deceleration time	00250 or less	5s	0–3600s/ 0–360s ①	Set the motor deceleration time.	29 Acceleration/deceleration pattern selection	6.11.3
		00310 or more	15s				
20	Acceleration/deceleration reference frequency	50Hz	1–400Hz	Set the frequency that will be the basis of acceleration/deceleration time. As acceleration/deceleration time, set the frequency change time from stop to Pr. 20.		125 Frequency setting gain frequency 126 Frequency setting gain frequency	6.20.5 6.20.5
21	Acceleration/deceleration time increments	0	0	Increments: 0.1s Range: 0–3600s	Increments and setting range of acceleration/deceleration time setting can be changed.	178–189 Input terminal function selection	6.14.1
			1	Increments: 0,01 s Range: 0–360s			
44	Second acceleration/deceleration time	5s	0–3600s/ 0–360s ①	Set the acceleration/deceleration time when the RT signal is on.			
45	Second deceleration time	9999	0–3600s/ 0–360s ①	Set the deceleration time when the RT signal is on.			
			9999	Acceleration time = deceleration time			
110	Third acceleration/deceleration time	9999	0–3600s/ 0–360s ①	Set the acceleration/deceleration time when the X9 signal is on.			
			9999	Without the third acceleration/deceleration function.			
111	Third deceleration time	9999	0–3600s/ 0–360s ①	Set the acceleration/deceleration time when the RT signal is on.			
			9999	Acceleration time = deceleration time			

① Depends on the Pr. 21 "Acceleration/deceleration time increments" setting. The initial value for the setting range is "0 to 3600s" and the setting increments is "0.1s".

**Acceleration time setting (Pr. 7, Pr. 20)**

Use Pr. 7, 44 and 110 to set the acceleration time required to reach Pr. 20 "Acceleration/deceleration reference frequency" from 0Hz. The setting value of Pr. 13 "Starting frequency" must be considered.

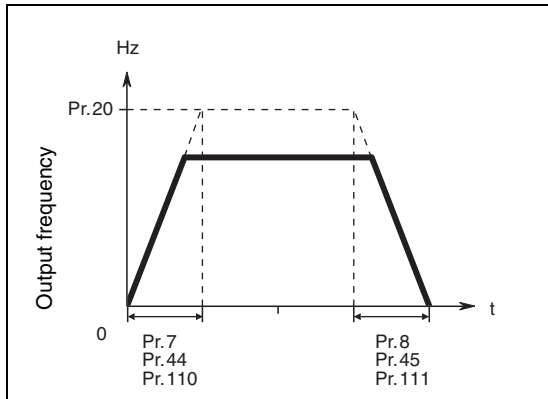

**Fig. 6-77:**  
Acceleration/deceleration time

1000006E

Set the acceleration time according to the following formula:

$$\text{Acceleration time setting} = \frac{\text{Pr. 20}}{\text{Maximum operating frequency} \square \text{Pr. 13}} \times \frac{\text{Acceleration time from stop to maximum operating frequency}}{\text{Maximum operating frequency}}$$

**Example ▽**

When Pr. 20 = 50Hz (initial value), Pr. 13 = 0.5Hz

The acceleration can be made up to the maximum operating frequency of 40Hz in 10s.

$$\text{Pr. 7} = \frac{50\text{Hz}}{40\text{Hz} \square 0,5\text{Hz}} \times 10\text{s} \square 12.7\text{s}$$

△

**Deceleration time setting (Pr. 8, Pr. 20)**

Use Pr. 8 "Deceleration time" to set the deceleration time required to reach 0Hz from Pr. 20 "Acceleration/deceleration reference frequency". When the DC injection brake is activated, the setting value of Pr. 10 must be considered

Set the deceleration time according to the following formula:

$$\text{Deceleration time setting} = \frac{\text{Pr. 20}}{\text{Maximum operating frequency} \square \text{Pr. 10}} \times \frac{\text{Deceleration time from maximum operating frequency to stop}}{\text{Maximum operating frequency}}$$

**Example ▽**

When Pr. 20 = 120Hz, Pr. 10 = 3Hz

The deceleration can be made up from the maximum operating frequency of 40Hz to a stop in 10s.

$$\text{Pr. 8} = \frac{120\text{Hz}}{40\text{Hz} \square 3\text{Hz}} \times 10\text{s} \square 32.4\text{s}$$

△

**Change the setting range and increments of the acceleration/deceleration time (Pr. 21)**

Use Pr. 21 to set the acceleration/deceleration time and minimum setting range.

Setting "0" (initial value) 0 to 3600s (minimum setting increments 0.1s)

Setting "1" 0 to 360s (minimum setting increments 0.01s)

**CAUTION:**

***Changing the Pr. 21 setting changes the acceleration/deceleration setting (Pr. 7, Pr. 8, Pr. 16, Pr. 44, Pr. 45, Pr. 110, Pr. 111, Pr. 264, Pr. 265).***

***(The Pr. 611 "Acceleration time at a restart" setting is not affected.)***

**Example:**

***When Pr. 21 = 0, setting "5.0" s in Pr. 7 and "1" in Pr. 21 automatically changes the Pr. 7 setting to "0.5" s.***

**Set multiple acceleration/deceleration time (RT signal, Pr. 44, Pr. 45, Pr. 110, Pr. 111)**

- Switching the parameter sets allows you to operate motors with different specifications and capabilities with the frequency inverter.
- Pr. 44 and Pr. 45 are valid when the RT signal is on, and Pr. 110 and Pr. 111 are valid when the X9 signal is on. When both the RT and X9 are on, Pr. 110 and Pr. 111 are valid. For the terminal used for X9 signal input, set "9" in any of Pr. 178 to Pr. 189 (input terminal function selection) to assign the function.
- When "9999" is set in Pr. 45 or Pr. 110, the deceleration time becomes equal to the second acceleration time (Pr. 44, Pr. 111).
- When Pr. 110 = "9999", third acceleration/deceleration time is invalid.
- The RT (X9) signal acts as the second (third) function selection signal and makes the other second (third) function valid.
- The RT and X9 signal can be assigned to the input terminal using any of Pr. 178 to Pr. 189 (input terminal function selection).

**S-shaped acceleration/deceleration pattern**

If a S-shaped acceleration/deceleration pattern A is selected in pr. 29, the set time is the period required to reach the base frequency set in Pr. 3 "Base frequency".

Acceleration/deceleration time formula when the set frequency is the base frequency or higher.

$$t = \frac{4}{9} \times \frac{T}{(\text{Pr. 3})^2} \times f^2 + \frac{5}{9} T$$

T:Acceleration/deceleration time setting value (s)

f:Set frequency (Hz)

**NOTE**

For a detailed description of Pr. 29 please refer to section 6.11.3.

Guideline for acceleration/deceleration time when Pr. 3 "Base frequency" = 50Hz (0Hz to set frequency).

Acceleration/deceleration time [s]	Frequency Setting [Hz]			
	50	120	200	400
5	5	16	38	145
15	15	47	115	435

**Tab. 6-40:** Acceleration/deceleration time at a base frequency of 50Hz

**NOTES**

The RT signal is assigned to the RT terminal in the default setting. By setting "3" to any of Pr. 178 to Pr. 189 "Input terminal function selection", you can assign the RT signal to an other terminal.

The RT signal can be assigned to the input terminal using any of Pr. 178 to Pr. 189 "Input terminal function selection". When terminal assignment is changed, the other functions may be affected. Please make setting after confirming the function of each terminal.

If the Pr. 20 setting is changed, the Pr. 125 and Pr. 126 ("Frequency setting signal gain frequency") settings do not change.

When the Pr. 7, Pr. 8, Pr. 44, Pr. 45, Pr. 110 or Pr. 111 settings are 0.03s or less, the acceleration/deceleration time is 0.04s (under V/f control or advanced magnetic flux vector control).

If the acceleration/deceleration time is set, the actual motor acceleration/deceleration time cannot be made shorter than the shortest acceleration/deceleration time determined by the mechanical system J (inertia moment) and motor torque.

### 6.11.2 Starting frequency and start-time hold function

You can set the starting frequency and hold the set starting frequency for a certain period of time. Set these functions when you need the starting torque or want to smooth motor drive at a start.

Pr. No.	Name	Initial Value	Setting Range	Description	Parameters referred to	Refer to Section
13	Starting frequency	0.5Hz	0–60Hz	Frequency at start can be set in the range 0 to 60Hz. You can set the starting frequency at which the start signal is turned on.	2 Minimum frequency	6.8.1
571	Holding time at start	9999	0.0–10.0s	Set the holding time of Pr. 13 "Starting frequency".		
			9999	Holding function at a start is invalid		

#### Starting frequency setting (Pr. 13)

The motor is started with the specified start frequency as soon as the frequency inverter receives a start signal and a frequency setting that is greater than or equal to the preset starting frequency.

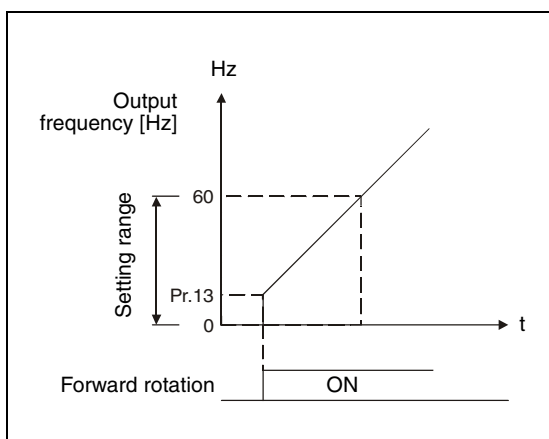

**Fig. 6-78:**  
Starting frequency parameter

1000008C

**NOTE**

The inverter will not start if the frequency setting signal is less than the value set in Pr. 13.

**Example** ▽

When 5Hz is set in Pr. 13, the motor will not start running until the frequency setting signal reaches 5Hz.



**WARNING:**

*Note that when Pr. 13 is set to any value lower than Pr. 2 "Minimum frequency", simply turning on the start signal will run the motor at the preset frequency even if the command frequency is not input.*

**Start-time hold function (Pr. 571)**

This function holds the time set in Pr. 571 and the output frequency set in Pr. 13 "Starting frequency".

This function performs initial excitation to smooth the motor drive at a start.

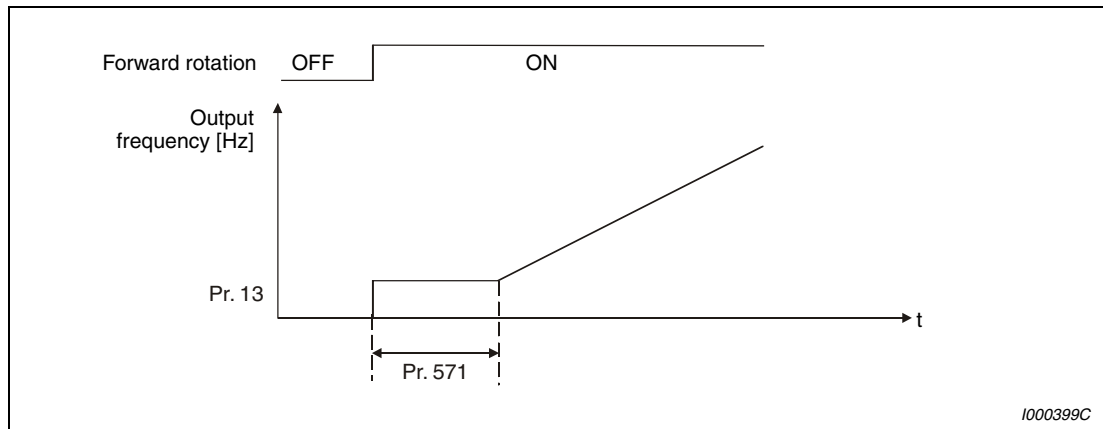

**Fig. 6-79:** Holding time at start

**NOTES**

When the start signal was turned off during start-time hold, deceleration is started at that point.

At switching between forward rotation and reverse rotation, the starting frequency is valid but the start-time hold function is invalid.

When Pr. 13 = 0Hz, the starting frequency is held at 0.01Hz.



### 6.11.3 Acceleration and deceleration pattern (Pr. 29, Pr. 140 to Pr. 143, Pr. 380 to Pr. 383, Pr. 516 to Pr. 519)

You can set the acceleration/deceleration pattern suitable for application.

You can also set the backlash measures that stop acceleration/deceleration once at the parameter-set frequency and time during acceleration/deceleration.

Pr. No.	Name	Initial Value	Setting Range	Description	Parameters referred to	Refer to Section	
<b>29</b>	Acceleration/deceleration pattern selection	0	0	Linear acceleration/deceleration	178-189	6.14.1	
			1	S-pattern acceleration/deceleration A			
			2	S-pattern acceleration/deceleration B			
			3	Backlash measures			
			4	S-pattern acceleration/deceleration C			
			5	S-pattern acceleration/deceleration D			
<b>140</b>	Backlash acceleration stopping frequency	1 Hz	0-400 Hz	Set the stopping frequency and time for backlash measures. Valid when Pr. 29 = 3	3	Base frequency	6.9.1
<b>141</b>	Backlash acceleration stopping time	0.5 s	0-360 s		7	Acceleration time	6.11.1
<b>142</b>	Backlash deceleration stopping frequency	1 Hz	0-400 Hz		8	Deceleration time	6.11.1
<b>143</b>	Backlash deceleration stopping time	0.5 s	0-360 s		20	Acceleration/deceleration reference frequency	6.11.1
<b>380</b>	Acceleration S-pattern 1	0	0-50 %	Valid when S-pattern acceleration/deceleration C (Pr. 29 = 4) is set. Set the time taken for S-pattern from starting of acceleration/deceleration to linear acceleration as % to the acceleration/deceleration time (Pr. 7, Pr. 8 etc.). An acceleration/deceleration pattern can be changed with the X20 signal.	178-189	6.14.1	
<b>381</b>	Deceleration S-pattern 1	0	0-50 %				
<b>382</b>	Acceleration S-pattern 2	0	0-50 %				
<b>383</b>	Deceleration S-pattern 2	0	0-50 %				
<b>516</b>	S-pattern time at a start of acceleration	0.1 s	0.1-2.5 s	Valid when S-pattern acceleration/deceleration D (Pr. 29 = 5) is set. Set the time taken for S-pattern acceleration/deceleration (S-pattern operation).	178-189	6.14.1	
<b>517</b>	S-pattern time at a completion of acceleration	0.1 s	0.1-2.5 s				
<b>518</b>	S-pattern time at a start of deceleration	0.1 s	0.1-2.5 s				
<b>519</b>	S-pattern time at a completion of deceleration	0.1 s	0.1-2.5 s				

**Linear acceleration/deceleration (Pr. 29 = 0, initial value)**

When the frequency is changed for acceleration, deceleration, etc. in inverter operation, the output frequency is changed linearly (linear acceleration/deceleration) to reach the set frequency without straining the motor and inverter. Linear acceleration/deceleration has a uniform frequency/time slope (refer to Fig. 6-80).

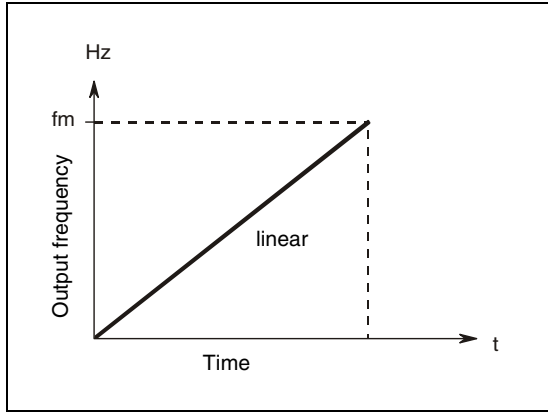
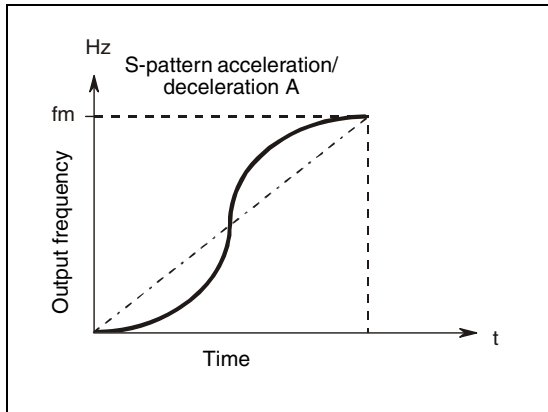

**Fig. 6-80:**  
Characteristic for parameter 29 = 0

1000015C

**S-pattern acceleration/deceleration A (Pr. 29 = 1)**

For machine tool spindle applications, etc.  
Used when acceleration/deceleration must be made in a short time to a high-speed range of not lower than base frequency. In this acceleration/deceleration pattern, Pr. 3 Base frequency (fb) is the inflection point of the S pattern and you can set the acceleration/deceleration time appropriate for motor torque reduction in a constant-power operation region of Pr. 3 Base frequency (refer to Fig. 6-81).



**Fig. 6-81:**  
Characteristic for parameter 29 = 1

1000016C

**NOTE**

As the acceleration/deceleration time of S-pattern acceleration/deceleration A, set the time taken until Pr. 3 "Base frequency" is reached, not Pr. 20 "Acceleration/deceleration reference frequency".

**S-pattern acceleration/deceleration B (Pr. 29 = 2)**

When a setting of “2” is entered frequency changes are executed with an S-pattern. For example, if a drive is accelerated from 0 to 30Hz and then re-accelerated to 50Hz then each acceleration sequence (i.e. the first sequence from 0 to 30Hz and the second from 30Hz to 50Hz) will be executed with an S-pattern. The time for the S-pattern is not longer than that for linear acceleration (refer to Fig. 6-82). This prevents jolts in drive operation, for example for conveyor belt and positioning drive systems.

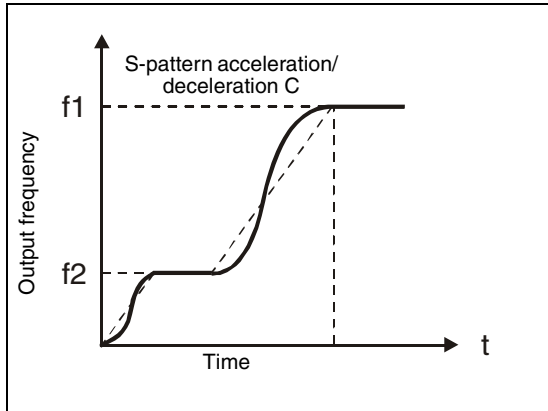

**Fig. 6-82:**  
Characteristic for parameter 29 = 2

1000017C

**Backlash measures (Pr. 29 = 3, Pr. 140 to Pr. 143)**

What is backlash?

Reduction gears have an engagement gap and have a dead zone between forward rotation and reverse rotation. This dead zone is called backlash, and this gap disables a mechanical system from following motor rotation.

More specifically, a motor shaft develops excessive torque when the direction of rotation changes or when constant-speed operation shifts to deceleration, resulting in a sudden motor current increase or regenerative status.

To avoid backlash, acceleration/deceleration is temporarily stopped.

Set the acceleration/deceleration stopping frequency and time in Pr. 140 to Pr. 143.

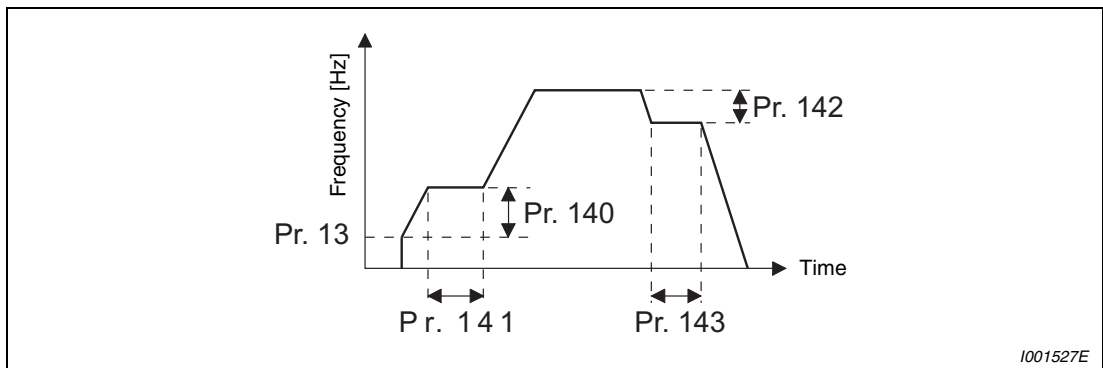

**Fig. 6-83:** Anti-backlash measure function

1001527E

**NOTE**

Setting the backlash measures increases the acceleration/deceleration time by the stopping time.

**S-pattern acceleration/deceleration C (Pr. 29 = 4, Pr. 380 to Pr. 383)**

With the S-pattern acceleration/deceleration C switch signal (X20), an acceleration/deceleration curve S-pattern 1 or S-pattern 2 can be selected. For the terminal used for X20 signal input, set "20" in any of Pr. 178 to Pr. 189 (input terminal function selection) to assign the function.

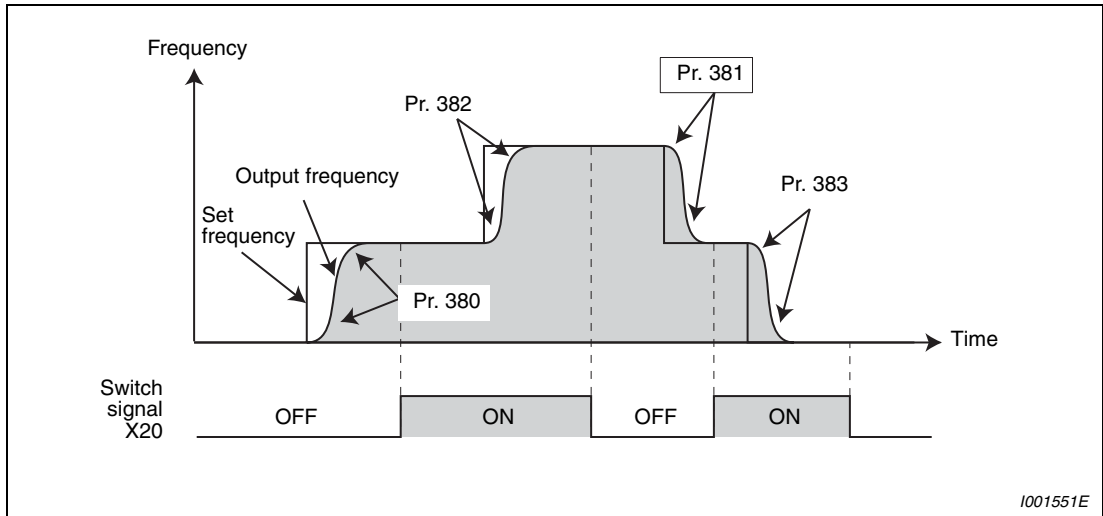

**Fig. 6-84:** Characteristic for parameter 29 = 4

X20	During Acceleration	During Deceleration
AUS	Pr. 380 Acceleration S-pattern 1	Pr. 381 Deceleration S-pattern 1
EIN	Pr. 382 Acceleration S-pattern 2	Pr. 383 Deceleration S-pattern 2

**Tab. 6-41:** Selection of acceleration/deceleration curve S-pattern 1 or S-pattern 2

Set % of time taken for forming an S-pattern in Pr. 380 to Pr.383 as acceleration time is 100%.

Parameter setting [%]  $\square \frac{T_s}{T} \times 100 \%$

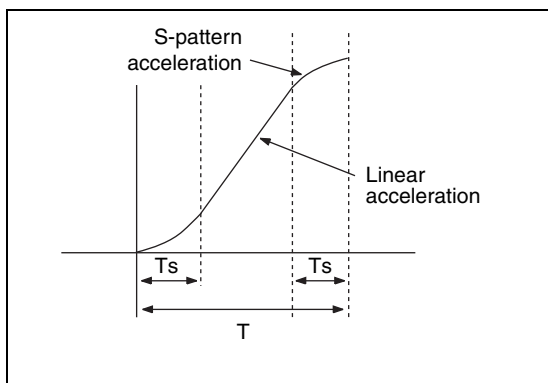

**Fig. 6-85:** Parameter setting

**NOTES**

At a start, the motor starts at Pr. 13 Starting frequency when the start signal turns on.

If there is a difference between the speed command and speed at a start of deceleration due to torque limit operation etc., the speed command is matched with the speed to make deceleration.

Change the S pattern acceleration/deceleration C switch (X20 signal) after the speed becomes constant.

S pattern operation before switching continues even if the X20 signal is changed during acceleration or deceleration.

The X20 signal can be assigned to the input terminal using any of Pr. 178 to Pr. 189 (input terminal function selection). Changing the terminal assignment may affect the other functions. Make setting after confirming the function of each terminal.

**S-pattern acceleration/deceleration D (Pr. 29 = 5, Pr. 516 to Pr. 519)**

Set the time taken for S-pattern operation of S-pattern acceleration/deceleration using Pr. 516 to Pr. 519. Set each S-pattern operation time for acceleration start (Pr. 516), acceleration completion (Pr. 517), deceleration start (Pr. 518) and deceleration completion (Pr. 519).

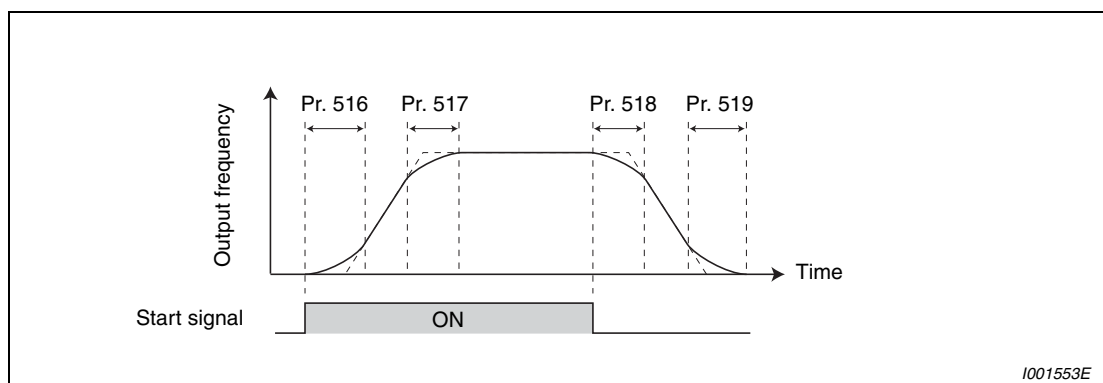

**Fig. 6-86:** Characteristic for parameter 29 = 5

When S-pattern acceleration/deceleration D is set, acceleration/deceleration time will become longer as follows:

Actual acceleration time  $T_2 = \text{set acceleration time } T_1 + (\text{S-pattern time at a start of acceleration} + \text{S-pattern time at a completion of acceleration}) / 2$

Actual deceleration time  $T_2 = \text{set deceleration time } T_1 + (\text{S-pattern time at a start of deceleration} + \text{S-pattern time at a completion of deceleration}) / 2$

Set acceleration/deceleration time  $T_1$  indicates Pr. 7, Pr. 8, Pr. 44, Pr. 45, Pr. 110 and Pr. 111.

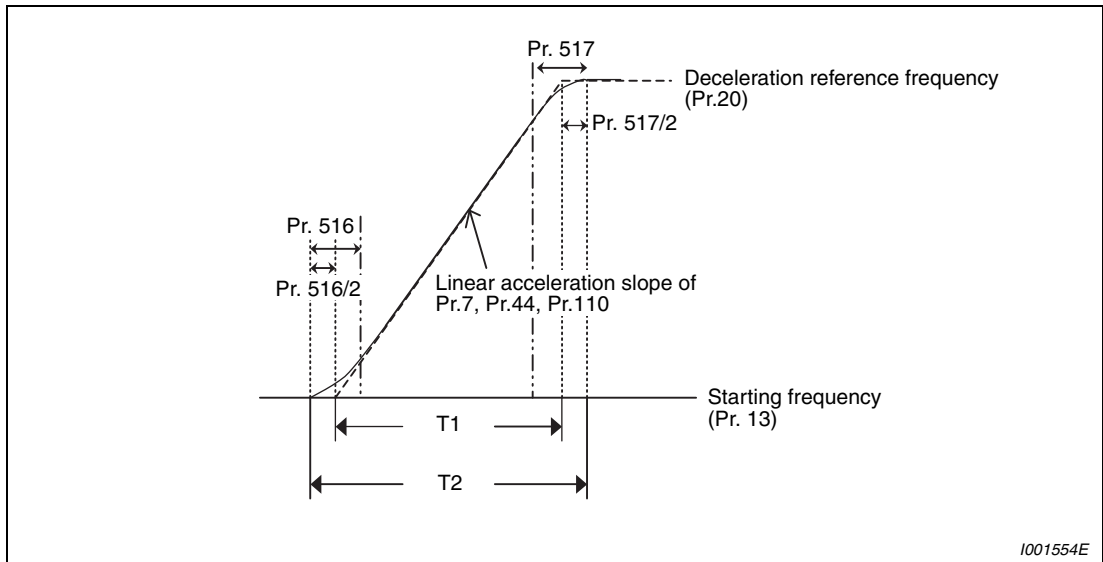

Fig. 6-87: S-pattern time



**CAUTION:**

*Even if the start signal is turned off during acceleration, the inverter will not decelerate immediately to avoid sudden frequency change. (Likewise, the inverter will not immediately accelerate when deceleration is changed to reacceleration by turning the start signal on during deceleration, etc.)*

**Example** ▽

The actual acceleration time when starting the inverter with an S-pattern acceleration/deceleration pattern D selected for a stop to 50Hz in the parameter initial setting is as shown below (refer also to Fig. 6-87):

Set acceleration time  $T_1 = (\text{Pr. 20} - \text{Pr. 13}) \times \text{Pr. 7} / \text{Pr. 20}$

Actual acceleration time  $T_2 = \text{Set acceleration time } T_1 + (\text{Pr. 516} + \text{Pr. 517}) / 2$

Set acceleration time  $T_1 = (50 \text{ Hz} - 0,5 \text{ Hz}) \times 5 \text{ s} / 50 \text{ Hz} = 4,95 \text{ s (at linear acceleration)}$

Actual acceleration time  $T_2 = 4,95 \text{ s} + (0,1 \text{ s} + 0,1 \text{ s}) / 2 = 5,05 \text{ s (at S-pattern acceleration)}$



**NOTES**

When the acceleration/deceleration time (Pr. 7, Pr. 8, etc.) setting under real sensorless vector control or vector control is 0s, the S-pattern acceleration/deceleration A to D (Pr. 29 = "1, 2, 4, 5") is linear acceleration/deceleration.

Set linear acceleration/deceleration (Pr. 29 = "0 (initial value)") when torque control is exercised under real sensorless vector control or vector control. When acceleration/deceleration patterns other than the linear acceleration/deceleration are selected, the protective function of the inverter may function.

### 6.11.4 Shortest acceleration/deceleration (automatic acceleration/deceleration) (Pr. 61 to Pr. 63, Pr. 292, Pr. 293)

The inverter operates in the same conditions as when appropriate values are set in each parameter even if acceleration/deceleration time and V/f pattern are not set. This function is useful when you just want to operate, etc. without fine parameter setting.

Pr. No.	Name	Initial Value	Setting Range	Description	Parameters referred to	Refer to Section	
61	Reference current	9999	01800 or less	0-500A	Set the reference current during shortest / optimum acceleration/deceleration.	0 Torque boost 7 Acceleration time 8 Deceleration time 22 Stall prevention operation level 22 Torque limiter	6.7.1 6.11.1 6.11.1 6.7.4 6.3.2
			02160 or more	0-3600A			
			9999		Rated inverter output current value is reference		
62	Reference value at acceleration	9999	0-220% <sup>①</sup>	Set the limit value during shortest / optimum acceleration.			
			9999	Shortest acceleration: 150% is a limit value Optimum acceleration: Pr. 61 is reference			
63	Reference value at deceleration	9999	0-220% <sup>①</sup>	Set the limit value during shortest / optimum deceleration.			
			9999	Shortest deceleration: 150% is a limit value Optimum deceleration: Pr. 61 is reference			
292	Automatic acceleration/deceleration	0	0	Normal mode			
			1	Shortest acceleration/deceleration (without brake)			
			11	Shortest acceleration/deceleration (with brake)			
			3	Optimum acceleration/deceleration			
			5/6	Elevator mode 1, 2 (Refer to section 6.9.3)			
			7/8	Brake sequence mode 1, 2 (Refer to section 6.13.5.)			
293	Acceleration/deceleration separate selection	0	0	Both acceleration and deceleration are made in the shortest acceleration/deceleration mode			
			1	Only acceleration is made in the shortest acceleration/deceleration mode			
			2	Only deceleration is made in the shortest acceleration/deceleration mode			

<sup>①</sup> When Pr. 570 Multiple rating setting ≠ "2", performing all parameter clear and inverter reset changes the setting range (refer to section 6.7.5).



**Shortest acceleration/deceleration mode (Pr. 292 = 1, 11, Pr. 293)**

- Set when you want to accelerate/decelerate the motor for the shortest time. It is desired to make acceleration/deceleration in a shorter time for a machine tool etc. but the design values of machine constants are unknown.
- Acceleration/deceleration speed is automatically adjusted at a start of acceleration/deceleration from the value of the setting value of Pr. 7 "Acceleration time" and Pr. 8 "Deceleration time" so that acceleration/deceleration is made with the maximum torque the inverter can output. (The setting values of Pr. 7 and Pr. 8 are not changed.)
- Either acceleration or deceleration can be made in the shortest time using Pr. 293 "Acceleration/deceleration separate selection". When the setting value is "0" (initial value), both acceleration and deceleration can be made in the shortest time.
- Since the 00250 or less inverter has a built-in brake resistor, set Pr. 292 to "11". Set "11" also when a high-duty brake resistor or brake unit is connected. Deceleration time can be further shortened.
- When the shortest/acceleration mode is selected, the stall prevention operation level during acceleration/deceleration from the value of becomes 150% (adjustable using Pr. 61 to Pr. 63). Setting of Pr. 22 "Stall prevention operation level" is used only during a constant speed operation.
- Adjustment using Pr. 61 to Pr. 63 can not be made under real sensorless vector control or vector control since torque limit level (Pr. 22 etc.) is used during acceleration/deceleration.
- It is inappropriate to use for the following applications.
  - Machine with a large inertia such as a fan (more than 10 times). Since stall prevention operation will be activated for a long time, this type of machine may be brought to an alarm stop due to motor overloading, etc.
  - It is desired to always perform operation with a constant acceleration/deceleration time.
  - It is desired to perform operation making sure the inverter and motor have enough capability.

**NOTES**

If automatic acceleration/deceleration mode has been selected, inputting the jog signal (jog operation), RT signal (second function selection) or X9 signal (third function selection) during an inverter stop will switch to the normal operation and give priority to jog operation, second function selection or third function selection. Note that JOG and RT signal input is invalid even if JOG signal and RT signal are input during operation in automatic acceleration/deceleration mode.

Since acceleration/deceleration is made with the stall prevention operation being activated, the acceleration/deceleration speed always varies according to the load conditions.

Note that when proper values are set in Pr. 7 and Pr. 8, acceleration/deceleration time may be shorter than selecting shortest acceleration/deceleration mode.

**Optimum acceleration/deceleration mode (Pr. 292 = 3)**

- The optimum operation within the rating range where the inverter can be continuously used regardless of the inverter capability is performed. Automatically set torque boost and acceleration/deceleration time so that the average current during acceleration/deceleration is the rated current by the self-learning of the inverter.  
It is appropriate for applications such as automatic transfer machine, etc. which is small in load change and is operated in a predetermined pattern.
- At the initial time when the optimum acceleration/deceleration mode has been selected, operation is performed at the values set in Pr. 0 Torque boost, Pr. 7 Acceleration time and Pr. 8 Deceleration time. After operation, the average current and peak current are calculated from the motor current during acceleration/deceleration. These values are compared with the reference current (initial value is rated inverter current) and calculated, then more appropriate values are set in Pr. 0, Pr. 7 and Pr. 8. After that, operation is performed under the conditions of Pr. 0, Pr. 7 and Pr. 8 set, and more appropriate values are calculated. Note that the Pr. 0 value will not change under advanced magnetic flux vector control, real sensorless vector control or vector control.
- Storage of parameters  
The optimum values of Pr. 0, Pr. 7 and Pr. 8 are written to both the parameter RAM and EEPROM only three times of acceleration/deceleration after the optimum acceleration/deceleration mode has been selected or after the power is switched on or the inverter is reset. At of after the fourth attempt, they are not stored into EEPROM. Hence, after power-on or inverter reset, the values changed at the third time are valid. Note that the values changed at the fourth or later time are calculated to optimum and the values of Pr. 0, Pr. 7 and Pr. 8 are set to RAM, the values can be stored into EEPROM by reading and writing the values with the operation panel and paramter unit.

Number of Optimum Value Changes	Pr. 0, Pr. 7, Pr. 8		Optimum Conditions
	EEPROM value	RAM value	
1 to 3 times	Updated	Updated	Updated
4 times or more	Unchanged from third value	Updated	Updated

**Tab. 6-42: Storage of optimum values**

- Either acceleration or deceleration can be made in the optimum acceleration/deceleration mode using Pr. 293 Acceleration/deceleration separate selection. When the setting value is "0" (initial value), both acceleration and deceleration are made in the optimum acceleration/deceleration mode.
- It is inappropriate for machines which change in load and operation conditions. Since the stored optimum values are used for the next operation, faults, e.g. acceleration/deceleration is not made if conditons change, alarm stop is made due to overcurrent protective function, may occur.

**NOTES**

If shortest acceleration/deceleration mode has been selected, inputting the jog signal (jog operation), RT signal (second function selection) or X9 signal (third function selection) during an inverter stop will switch to the normal operation and give priority to jog operation, second function selection or third function selection. Note that JOG and RT signal input is invalid even if JOG signal and RT signal are input during operation in shortest/optimum acceleration/deceleration mode.

Because of the learning system, this mode is not valid at the first operation after the optimum acceleration/deceleration mode is set.

The optimum value are operated on only when acceleration is made from a stop to 30Hz or more or when deceleration is made from 30Hz or more to stop.

When the motor is not connected or output current is less than 5% of the rated inverter current, optimum acceleration/deceleration mode will not function.

**Adjustment of shortest acceleration/deceleration mode (Pr. 61 to Pr. 63)**

By setting the adjustment parameters Pr. 61 and Pr. 63, the application range can be made wider.

Pr. No.	Name	Setting Range		Description
61	Reference current	01800 or less	0–500A	For example, when the motor and inverter are different in capacity, set the rated motor current value. Shortest acceleration/deceleration: Set reference current (A) of the stall prevention operation level during acceleration/deceleration. Optimum acceleration/deceleration: Set reference current (A) of the optimum current during acceleration/deceleration.
		02160 or more	0–3600A	
		9999 (initial value)		The rated inverter current is defined as reference.
62	Reference value at acceleration	0–200%		Set when it is desired to change the reference level of acceleration and deceleration. Shortest acceleration/deceleration: Set the stall prevention operation level (ratio to the current value of Pr. 61) during acceleration/deceleration. Shortest acceleration/deceleration: Set the optimum current level (ratio to the current value of Pr. 61) during acceleration/deceleration.
63	Reference value at deceleration	9999 (initial value)		Shortest acceleration/deceleration: The 150% value during shortest acceleration/deceleration is judged as the stall prevention operation level. Optimum acceleration/deceleration: 100% is the optimum value

**Tab. 6-43:** Adjustment parameter setting

**NOTES**

Pr. 61 to Pr. 63 are invalid when real sensorless vector control or vector control is selected in the shortest acceleration/deceleration mode.

Under advanced magnetic flux vector control, real sensorless vector control or vector control the elevator mode can not be activated.

Since the Pr. 61 to Pr. 63 settings automatically return to the initial value (9999) if the Pr. 292 setting is changed, set Pr. 292 first when you need to set Pr. 61 to Pr. 63.

## 6.12 Selection and protection of a motor

Purpose	Parameters that must be set		Refer to Section
Motor protection from overheat	Electronic thermal O/L relay	Pr. 9, Pr. 51	6.12.1
Use the constant torque motor	Applied motor	Pr. 71	6.12.2
The motor performance can be maximized for operation in magnetic flux vector control method.	Offline auto tuning	Pr. 82–Pr. 84, Pr. 90–Pr. 94, Pr. 96	6.12.3
High accuracy operation unaffected by the motor temperature and stable operation with high torque down to ultra low speed are performed	Online auto tuning	Pr. 95, Pr. 574	6.12.4

### 6.12.1 Motor protection from overheat (Electronic thermal relay function) (Pr. 9)

The FR-F 700 EC frequency inverters have an internal electronic motor protection function that monitors the motor frequency and motor current. Overload conditions are identified and the motor protection function is triggered on the basis of these two factors, in combination with the rated motor current. The electronic motor protection function is primarily for protection against overheating at intermediate speeds and high motor torques. The reduced cooling performance of the motor fan under these conditions is also taken into account.

Pr. No.	Name	Initial Value	Setting Range		Description	Parameters referred to	Refer to Section
9	Electronic thermal O/L relay	Rated inverter output current <sup>①</sup>	01800 or less	0–500A	Set the rated motor current.	71 Applied motor 72 PWM frequency selection	6.12.2 6.19.1
			02160 or more	0–3600A			
51	Second electronic thermal O/L relay <sup>②</sup>	9999	01800 or less	0–500A	Made valid when the RT signal is on.	178–189 Input terminal function selection 190–196 Output terminal function selection AU terminal	6.14.1 6.14.5 3.4
			02160 or more	0–3600A	Set the rated motor current.		
			9999		Second electronic thermal O/L relay invalid		

① The initial value of the 00023 and 00038 is set to 85% of the rated inverter current.

② When parameter is read using the FR-PU04, a parameter name different from an actual parameter is displayed.

**Electronic thermal O/L relay (Pr. 9)**

Set the rated current [A] of the motor in Pr.9. (When the power supply specification is 400V/440V 60Hz, set the 1.1 times the rated motor current.)

Set "0" to Pr. 9 when you do not want to activate the electronic thermal relay function, e.g. when using an external thermal relay with the motor. (Note that the output transistor protection of the inverter functions (E.THT).)

Set "1" or any of "13" to "18", "50", "53", "54" in Pr. 71. (This provides a 100% continuous torque characteristic in the low-speed range.) After this set the rated current of the motor to Pr. 9.

The figure below shows the electronic thermal relay function operation characteristic. The region on the right of the characteristic curve is the operation region. The region on the left of the characteristic curve is the non-operation region.

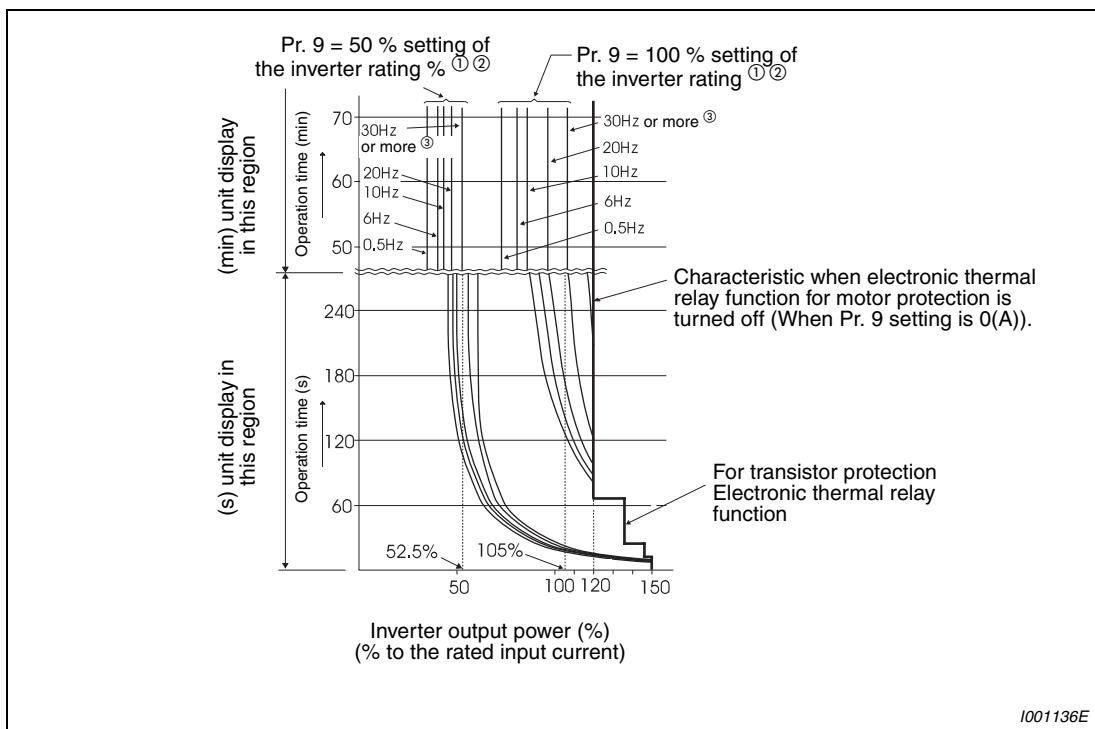

**Fig. 6-88:** Electronic thermal relay function operation characteristic

- ① When a value 50% of the inverter rated output current (current value) is set to Pr. 9.
- ② The % value denotes the percentage to the inverter rated output current. It is not the percentage to the motor rated current.
- ③ When you set the electronic thermal relay function dedicated to the Mitsubishi constant-torque motor, this characteristic curve applies to operation at 6Hz or higher.

**NOTES**

Protective function by electronic thermal relay function is reset by inverter power reset and reset signal input. Avoid unnecessary reset and power-off.

When multiple motors are operated by a single inverter, protection cannot be provided by the electronic thermal relay function. Install an external thermal relay to each motor.

When the difference between the inverter and motor capacities is large and the setting is small, the protective characteristics of the electronic thermal relay function will be deteriorated. In this case, use an external thermal relay.

A special motor cannot be protected by the electronic thermal relay function. Use the external thermal relay.

The operation time of the transistor protection thermal relay shortens when the Pr. 72 "PWM frequency selection" setting increases.

**Set multiple electronic thermal relay functions (Pr. 51)**

Use this function when rotating two motors of different rated currents individually by a single inverter. (When rotating two motors together, use external thermal relays.)

Set the rated current of the second motor in Pr. 51. When the RT signal is on, thermal protection is provided based on the Pr. 51 setting.

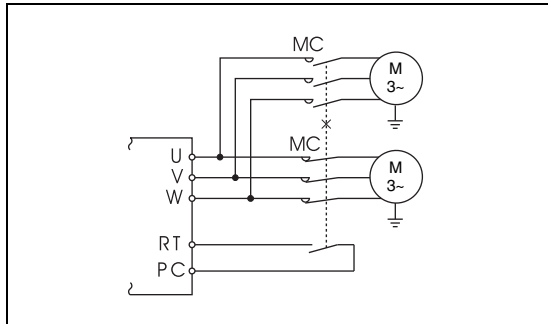

**Fig. 6-89:**  
Operating two motors by a single inverter

1001137C

Pr. 450 Second applied motor	Pr. 9 Electronic thermal O/L relay	Pr. 51 Second electronic thermal O/L relay	RT = OFF		RT = ON	
			First Motor	Second Motor	First Motor	Second Motor
9999	0	9999	—	—	—	—
		0	—	—	—	—
		0.01 to 500 (0.1 to 3600)	—	△	—	●
9999	≠ 0	9999	●	—	●	—
		0	●	—	—	—
		0.01 to 500 (0.1 to 3600)	●	△	△	●
≠ 9999	0	9999	—	—	—	—
		0	—	—	—	—
		0.01 to 500 (0.1 to 3600)	—	△	—	●
≠ 9999	≠ 0	9999	●	△	△	●
		0	●	—	△	—
		0.01 to 500 (0.1 to 3600)	●	△	△	●

**Tab. 6-44:** Switching of the electronic thermal relay

- Output current value is used to perform integration processing.
- △ Output current is assumed as 0A to perform integration processing. (cooling processing).
- Electronic thermal relay function is not activated.

**NOTES**

The RT signal acts as the second function selection signal and makes the other second functions valid.

The RT signal is assigned to the RT terminal in the initial setting. By setting "3" in any of Pr. 178 to Pr. 189 "Input terminal function selection", you can assign the RT signal to the other terminal.

**Electronic thermal relay function alarm output and alarm signal (THP signal)**

The alarm signal (THP) is output when the electronic thermal relay function cumulative value reaches 85% of the level set in Pr. 9 or Pr. 51. If it reaches 100% of the Pr. 9 "Electronic thermal O/L relay" setting, electronic thermal relay function protection (E. THM/E.THT) occurs.

**NOTE**

The prealarm signal "THP" is also issued as soon as the thermal load of the IGBT output stages of the frequency inverter is 85%. If the load rises further up to 100%, then the thermal overload protection of the frequency inverter responds and the "E.THT" error message is shown.

The inverter does not shut off the output if the alarm signal is output. For the terminal used for the THP signal output, assign the function by setting "8" (source logic) or "108" (sink logic) in any of Pr. 190 to Pr. 196 "Output terminal function selection".

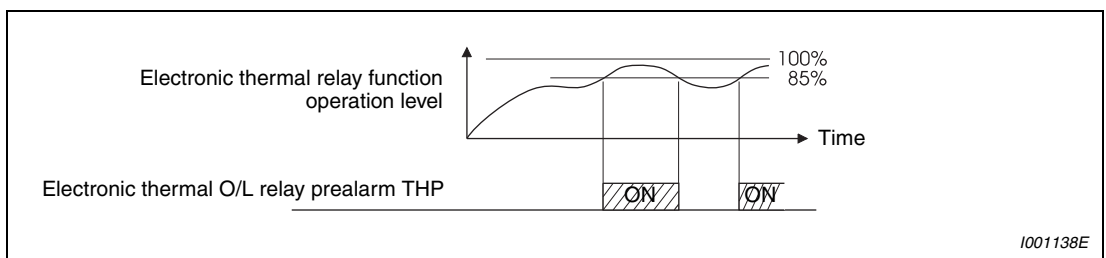

**Fig. 6-90:** Prealarm signal output

**NOTE**

The signal can be assigned to the input terminal using any of Pr. 190 to Pr. 196 "Output terminal function selection". When terminal assignment is changed, the other functions may be affected. Please make setting after confirming the function of each terminal.

**External thermal relay input (OH signal)**

To protect the motor against overheating, use the OH signal when using an external thermal relay or the built-in thermal protector of the motor.

When the thermal relay operates, the inverter shuts off the output and outputs the alarm signal (E.OHT).

For the terminal used for OH signal input, assign the function by setting "7" to any of Pr. 178 to Pr. 189 "Input terminal function selection".

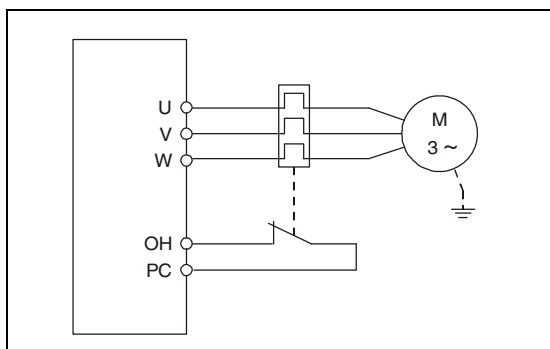

**Fig. 6-91:** Connection of an external thermal relay

**NOTE**

The signal can be assigned to the input terminal using any of Pr. 178 to Pr. 189 "Input terminal function selection". When terminal assignment is changed the other functions may be affected. Please make setting after confirming the function of each terminal.



**PTC thermistor input (PTC signal)**

PTC thermistor output built-in the motor can be input to the PTC signal (AU terminal).

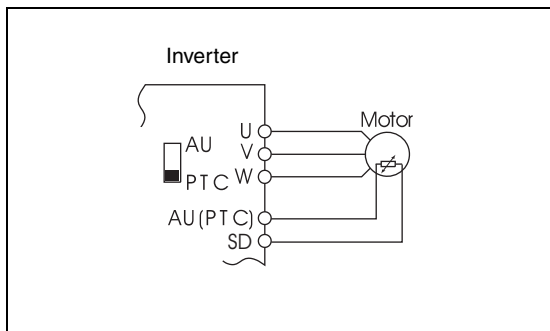

**Fig. 6-92:**  
Connection of a PTC thermistor

1001140E

For the terminal used for PTC signal input, assign the function by setting "63" to Pr. 184 "AU terminal function selection" and also set the AU/PTC switchover switch to the PTC terminal function. (The initial setting is the AU terminal function.)

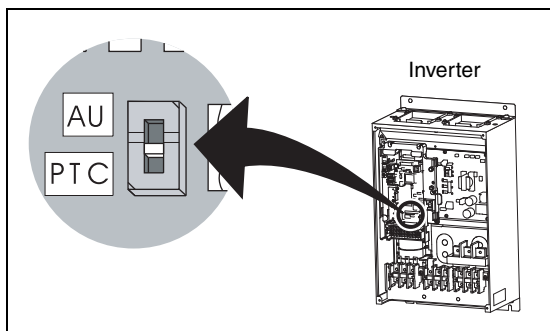

**Fig. 6-93:**  
AU/PTC switchover switch

1001141E

If a motor overheat state is detected for more than 10s according to the input from the PTC thermistor, the inverter shuts off the output and outputs the PTC thermal alarm signal (E.PTC).

The table below shows the correspondence between the motor temperature and the PTC thermistor resistance values:

Motor Temperature	PTC Thermistor Resistance Value [ $\Omega$ ]
Normal	0 to 500
Boundary	500 to 4k
Overheat	4k or higher

**Tab. 6-45:** Working area of the PTC function

**NOTES**

When the PTC signal was not assigned to Pr. 184 and the AU/PTC switchover switch was set to the PTC terminal function, the function assigned to the AU terminal is always off. Reversely, when the PTC signal was assigned to Pr. 184 and the AU/PTC switchover switch was set to the AU terminal function, a PTC thermal error (E.PTC) occurs since the function is always in a motor overheat state.

When you want to input a current, assign the AU signal to the other signal.

When terminal assignment is changed, the other functions may be affected. Please make setting after confirming the function of the AU terminal.

### 6.12.2 Applied motor (Pr. 71, Pr. 450)

Setting of the used motor selects the thermal characteristic appropriate for the motor. Setting is required to use a constant-torque motor. Thermal characteristic of the electronic thermal relay function suitable for the motor is set.

When general-purpose magnetic flux vector or advanced magnetic flux vector control is selected, the motor constants (SF-JR, SF-HR, SF-JRCA, SF-HRCA, etc.) necessary for control are selected as well..

Pr. No.	Name	Initial Value	Setting Range	Description	Parameters referred to	Refer to Section
<b>71</b>	Applied motor	0	0-8/13-18/20/ 23/24/30/33/ 34/40/43/44/ 50/53/54	Selecting the standard motor or constant-torque motor sets the corresponding motor thermal characteristic.	0 Torque boost	6.7.1
			0-8/13-18/20/ 23/24/30/33/ 34/40/43/44/ 50/53/54	Set when using the second motor (same specifications as Pr. 71)	12 DC injection brake operation voltage	6.13.1
<b>450</b>	Second applied motor	9999	0-8/13-18/20/ 23/24/30/33/ 34/40/43/44/ 50/53/54	Set when using the second motor (same specifications as Pr. 71)	80 Motor capacity	6.7
			9999	Second motor is invalid	81 Number of motor poles	6.7
					453 Second motor capacity	6.7
					454 Number of second motor poles	6.7
					82-84 Motor constants	6.12.3
					90-94	
					96	
					455-463	
					859	
					860	
					95 Online auto tuning selection	6.12.4
					574 Second motor online auto tuning	6.12.4
					451 Second motor control method selection	6.2.2
					800 Control method selection	6.2.2
					100-109 Adjustable 5 points V/f	6.9.4

**Set the motor to be used**

Refer to the following list and set this parameter according to the motor used.

Pr. 71	Pr. 450	Thermal Characteristic of the Electronic Thermal Relay Function		Motor		
				Standard (SF-JR, etc.)	Constant torque (SF-JRCA, etc.)	Vector (SF-V5RU)
0 (initial value)		Thermal characteristics of a standard motor		✓		
1		Thermal characteristics of the Mitsubishi constant-torque motor			✓	
2		Thermal characteristics of a standard motor Adjustable 5 points V/f (Refer to section 6.9.4)		✓		
20		Mitsubishi standard motor (SF-JR 4P 1.5kW or less) thermal characteristic for the constant-torque motor		✓		
30		Vector control dedicated motor (SF-V5RU)				✓
40		Thermal characteristic of Mitsubishi high efficiency motor (SF-HR)		✓ ①		
50		Thermal characteristic of Mitsubishi constant torque motor (SF-HRCA)			✓ ②	
3		Standard motor	Select "Offline auto tuning setting"	✓		
13		Constant-torque motor			✓	
23		Mitsubishi standard motor (SF-JR 4P 1.5kW or less)		✓		
33		Vector control dedicated motor (SF-V5RU, SF-THY)				✓
43		Mitsubishi high efficiency motor (SF-HR)		✓ ①		
53		Mitsubishi constant-torque motor (SF-HRCA)			✓ ②	
4		Standard motor	Auto tuning data can be read, changed, and set.	✓		
14		Constant-torque motor			✓	
24		Mitsubishi standard motor (SF-JR 4P 1.5kW or less)		✓		
34		Vector control dedicated motor (SF-V5RU, SF-THY)				✓
44		Mitsubishi high efficiency motor (SF-HR)		✓ ①		
54		Mitsubishi constant-torque motor (SF-HRCA)			✓ ②	
5		Standard motor	Star connection	Direct input of motor constants	✓	
15		Constant-torque motor				✓
6		Standard motor	Delta connection	Direct input of motor constants	✓	
16		Constant-torque motor				✓
7		Standard motor	Star connection	Direct input of motor constants and offline auto tuning	✓	
17		Constant-torque motor				✓
8		Standard motor	Delta connection	Direct input of motor constants and offline auto tuning	✓	
18		Constant-torque motor				✓
—	9999 (initial value)	Without second applied motor				

**Tab. 6-46:** Setting of parameter Pr. 71 and Pr. 450

① Motor constants of Mitsubishi high efficiency motor SF-HR.

② Motor constants of Mitsubishi constant-torque motor SF-HRCA.

**NOTE**

For the 00170 and 00250, the Pr. 0 Torque boost and Pr. 12 DC injection brake operation voltage settings are automatically changed according to the Pr. 71 setting as follows.

Pr. 71	Standard Motor Setting 0, 2, 3 to 8, 20, 23, 24, 40, 43, 44	Constant Torque Motor Setting 1, 13 to 18, 50, 53, 54
Pr. 0	3%	2%
Pr. 12	4%	2%

**Tab. 6-47:** Changes of parameter 0 and 12 related to parameter 71

**Use two types motors (Pr. 450)**

- Set Pr. 450 "Second applied motor" to use two different motors with one inverter.
- When "9999" (initial value) is set, no function is selected.
- When a value other than "9999" is set in Pr. 450 turning the RT signal on makes the following parameter valid..

Function	RT Signal ON (second motor)	RT Signal OFF (first motor)
Applied motor	Pr. 450	Pr. 71
Control method selection	Pr. 451	Pr. 800
Motor capacity	Pr. 453	Pr. 80
Number of motor poles	Pr. 454	Pr. 81
Motor excitation current	Pr. 455	Pr. 82
Motor rated voltage	Pr. 456	Pr. 83
Rated motor frequency	Pr. 457	Pr. 84
Motor constant (R1)	Pr. 458	Pr. 90
Motor constant (R2)	Pr. 459	Pr. 91
Motor constant (L1)	Pr. 460	Pr. 92
Motor constant (L2)	Pr. 461	Pr. 93
Motor constant (X)	Pr. 462	Pr. 94
Auto tuning setting/status	Pr. 463	Pr. 96
Online auto tuning selection	Pr. 574	Pr. 95
Torque current	Pr. 860	Pr. 859

**Tab. 6-48:** Validation of parameters by the RT signal**NOTES**

The RT signal acts as the second function selection signal and makes the other second functions valid. (Refer to section 6.14.3.)

The RT signal is assigned to the terminal RT in the initial setting. By setting "3" in any of Pr. 178 to Pr. 189 (input terminal function selection), you can assign the RT signal to the other terminal.

Changing the terminal assignment using Pr. 178 to Pr. 189 "Input terminal function selection" may affect other functions. Make setting after confirming the function of each terminal.

**CAUTION:**

***Set this parameter correctly according to the motor used.  
Incorrect setting may cause the motor to overheat and burn.***

**6.12.3 Offline auto tuning**  
**(Pr. 71, Pr. 80 to Pr. 84, Pr. 90 to Pr. 94, Pr. 96, Pr. 450, Pr. 453 to Pr. 463, Pr. 684, Pr. 859, Pr. 860)** Magnetic flux Sensorless Vector

The motor performance can be maximized with offline auto tuning.

What is offline auto tuning?

- When performing advanced magnetic flux vector control, real sensorless vector control or vector control, the motor can be run with the optimum operating characteristics by automatically measuring the motor constants (offline auto tuning) even when each motor constants differs, other manufacturer's motor is used, or the wiring length is long.

Pr. No.	Name	Initial Value	Setting Range	Description	Parameters referred to	Refer to Section	
<b>71</b>	Applied motor	0	0 to 8/13 to 18/20/23/24/30/33/34/40/43/44/50/53/54	By selecting a standard motor or constant-torque motor, thermal characteristic and motor constants of each motor are set.	7 Acceleration time 8 Deceleration time 9 Electronic thermal O/L relay	6.11.1 6.11.1 6.12.1	
<b>80</b>	Motor capacity	9999	01800 or less	0.4 to 55kW	Applied motor capacity	71 Applied motor	6.12.2
			02160 or more	0 to 3600kW		80 Motor capacity	6.2.2
			9999		V/f control	81 Number of motor poles	6.2.2
<b>81</b>	Number of motor poles	9999	2/4/6/8/10		Number of motor poles	95 Online auto tuning selection	6.12.4
			12/14/16/18/20		X18 signal ON: V/f control Set 10 + number of motor poles.	156 Stall prevention operation selection	6.7.4
			9999		V/f control	178-189 Input terminal function selection	6.14.1
<b>82</b>	Motor excitation current	9999	01800 or less	0 to 500A	Tuning data (The value measured by offline auto tuning is automatically set.)	190-196 Output terminal function selection	6.14.5
			02160 or more	0 to 3600A		800 Control method selection	6.2.2
			9999		Uses the Mitsubishi motor (SF-JR, SF-HR, SF-JRCA, SF-HRCA) constants.		
<b>83</b>	Motor rated voltage	400V	0 to 1000V	Rated motor voltage (V)			
<b>84</b>	Rated motor frequency	50Hz	10 to 120Hz	Rated motor frequency (Hz)			

Pr. No.	Name	Initial Value	Setting Range		Description	Parameters referred to	Refer to Section
90	Motor constant (R1)	9999	01800 or less	0-50Ω/9999	Tuning data (The value measured by offline auto tuning is automatically set.) 9999: Use the Mitsubishi motor (SF-JR,SF-HR, SF-JRCA, SF-HRCA) constants	See previous page	
			02160 or more	0-400mΩ/9999			
91	Motor constant (R2)	9999	01800 or less	0-50Ω/9999			
			02160 or more	0-400mΩ/9999			
92	Motor constant (L1)	9999	01800 or less	0-50Ω/(0-1000 mH)/9999			
			02160 or more	0-3600 mΩ/(0-400 mH)/9999			
93	Motor constant (L2)	9999	01800 or less	0-50 Ω/(0-1000 mH)/9999			
			02160 or more	0-3600mΩ/(0-400 mH)/9999			
94	Motor constant (X)	9999	01800 or less	0-500Ω/(0-100 %)/9999			
			02160 or more	0-100Ω/(0-100 %)/9999			
96	Auto tuning setting/status	0	0		Offline auto tuning is not performed		
			1		Offline auto tuning is performed without motor running		
			101		Offline auto tuning is performed with motor running		
450	Second applied motor	9999	0 to 8/13 to18/20/23/24/30/33/34/40/43/44/50/53/54		Set when using the second motor. (same specifications as Pr. 71)		
			9999		Second motor is invalid		
453	Second motor capacity	9999	01800 or less	0.4 to 55kW	Set the capacity of the second motor.		
			02160 or more	0 to 3600kW			
			9999		V/f control		
454	Number of second motor poles	9999	2/4/6/8/10		Set the number of poles of the second motor.		
			9999		V/f control		
455	Second motor excitation current	9999	01800 or less	0 to 500A	Tuning data of the second motor (The value measured by offline auto tuning is automatically set.)		
			02160 or more	0 to 3600A			
			9999		Use the Mitsubishi motor (SF-JR, SFHR, SF-JRCA, SF-HRCA) constants		

Pr. No.	Name	Initial Value	Setting Range	Description	Parameters referred to	Refer to Section
456	Rated second motor voltage	400V	0 to 1000V	Set the rated voltage (V) of the second motor.	See top of section	
457	Rated second motor frequency	50Hz	10 to 120Hz	Set the rated motor frequency (Hz) of the second motor.		
458	Motorkonstante (R1) (Motor 2)	9999	01800 or less	0-50Ω/9999	Tuning data of the second motor (The value measured by offline auto tuning is automatically set.) 9999: Use the Mitsubishi motor (SF-JR, SF-HR, SF-JRCA, SF-HRCA) constants	
			02160 or more	0-400mΩ/9999		
459	Second motor constant (R2)	9999	01800 or less	0-50Ω/9999		
			02160 or more	0-400mΩ/9999		
460	Second motor constant (L1)	9999	01800 or less	0-50Ω/(0-1000 mH)/9999		
			02160 or more	0-3600mΩ/(0-400mH)/9999		
461	Second motor constant (L2)	9999	01800 or less	0-50Ω/(0-1000mH)/9999		
			02160 or more	0-3600mΩ/(0-400mH)/9999		
462	Second motor constant (X)	9999	01800 or less	0-500Ω/(0-100%)/9999		
			02160 or more	0-100Ω/(0-100%)/9999		
463	Second motor auto tuning setting/status	0	0	Second motor auto tuning is not performed		
			1	Offline auto tuning is performed without second motor running		
			101	Offline auto tuning is performed with second motor running		
684	Tuning data unit switchover	0	0	Internal data converted value		
			1	Display in "A, Ω, mH, %"		
859	Torque current	9999	01800 or less	0 to 500A	Tuning data (The value measured by offline auto tuning is automatically set.)	
			02160 or more	0 to 3600A		
			9999		Use the Mitsubishi motor (SF-JR, SFHR, SF-JRCA, SF-HRCA) constants	
860	Second motor torque current	9999	01800 or less	0 to 500A	Tuning data of the second motor (The value measured by offline auto tuning is automatically set.)	
			02160 or more	0 to 3600A		
			9999		Use the Mitsubishi motor (SF-JR, SFHR, SF-JRCA, SF-HRCA) constants	



- This function is made valid only when a value other than "9999" is set in Pr. 80 and Pr. 81 and advanced magnetic flux vector control, real sensorless vector control or vector control is selected.
- You can copy the offline auto tuning data (motor constants) to another inverter with the PU (FR-DU07/FR-PU07).
- Even when motors (other manufacturer's motor, SF-JRC, SF-TH, etc.) other than Mitsubishi standard motor, high efficiency motor (SF-JR SF-HR 0.4kW or more), Mitsubishi constant-torque motor (SF-JRCA SF-HRCA four-pole 0.4kW to 55kW) and vector control dedicated motor (SF-V5RU) are used or the wiring length is long, using the offline auto tuning function runs the motor with the optimum operating characteristics.
- Tuning is enabled even when a load is connected to the motor. (As the load is lighter, tuning accuracy is higher. Tuning accuracy does not change even if the inertia is large.)
- For the offline auto tuning, you can select either the motor non-rotation mode (Pr. 96 = "1") or rotation mode. (Pr. 96 = "101"). The rotation mode has higher tuning accuracy than the non-rotation mode.
- Reading/writing/copy of motor constants tuned by offline auto tuning are enabled.
- The offline auto tuning status can be monitored with the PU (FR-DU07/FR-PU07/FR-PU04).

**Before performing offline auto tuning**

Check the following before performing offline auto tuning.

- Make sure advanced magnetic flux vector control (Pr. 80, Pr. 81), real sensorless vector control or vector control (Pr. 800) is selected (refer to section 5.1.7)
- A motor should be connected. Note that the motor should be at a stop at a tuning start.
- The motor capacity should be equal to or one rank lower than the inverter capacity (note that the capacity is 0.4kW or more).
- The maximum frequency is 120Hz.
- A high-slip motor, high-speed motor and special motor cannot be tuned.
- Note the following when selecting offline auto tuning performed with motor running (Pr. 96 Auto tuning setting/status = "101"):
  - Torque is not enough during tuning.
  - The motor may be run at nearly its rated speed.
  - The brake is open.
  - No external force is applied to rotate the motor.
- Offline auto tuning will not be performed properly if it is performed with a surge voltage suppression filter (FR-ASFH) connected to the 01800 or less and sine wave filter (MT-BSL/BSC) connected to the 02160 or more between the inverter and motor. Remove it before starting tuning.
- When exercising vector control, use the encoder that is coupled directly to the motor shaft without looseness. Speed ratio should be 1:1.

**CAUTION:**

***Even if tuning is performed without motor running (Pr. 96 "Auto tuning setting/status" = "1"), the motor may run slightly. Therefore, fix the motor securely with a mechanical brake, or before tuning, make sure that there will be no problem in safety if the motor runs. (Caution is required especially in vertical lift applications). Note that if the motor runs slightly, tuning performance is unaffected.***

**Setting**

- Select the advanced magnetic flux vector control, real sensorless vector control or vector control (refer to section 6.2.2).
- Set "1" or "101" in Pr. 96 "Auto tuning setting/status".
  - When the setting is "1": Tuning is performed without motor running. It takes approximately 25 to 120s (depending on the inverter capacity and motor type) until tuning is completed. (Excitation noise is produced during tuning.)
  - When the setting is "101": Tuning is performed with motor running. It takes approximately 40s until tuning is completed. The motor runs at nearly its rated frequency
- Set the rated motor current (initial value is rated inverter current) in Pr. 9 "Electronic thermal O/L relay". (Refer to section 6.12.)
- Set the rated voltage of motor (initial value is 400V) in Pr. 83 "Motor rated voltage" and rated motor frequency (initial value is 50Hz) in Pr. 84 "Rated motor frequency".
- Set Pr. 71 "Applied motor" according to the motor used.

Motor		Pr. 71 <sup>①</sup>
Mitsubishi standard motor Mitsubishi high efficiency motor	SF-JR	3
	SF-JR 4P-1.5 kW or less	23
	SF-HR	43
	Others	3
Mitsubishi constant-torque motor	SF-JRCA 4P	13
	SF-HRCA	53
	Others (SF-JRC, etc.)	13
Vector control dedicated motor	SF-V5RU, SF-THY	33
Other manufacturer's standard motor	—	3
Other manufacturer's constant-torque motor	—	13

**Tab. 6-49: Motor selection**

<sup>①</sup> Refer to section 6.12.2 for other settings of Pr. 71.

## Execution of tuning

**CAUTION:**

***Before performing tuning, check the monitor display of the operation panel or parameter unit (FR-PU04/FR-PU07) if the inverter is in the status for tuning (refer to Tab. 6-50). When the start command is turned on under V/f control, the motor starts.***

When performing tuning or PU operation, press the RUN key of the operation panel or the FWD or REV key of the parameter unit (FR-PU04/FR-PU07).

For external operation, turn on the run command (STF signal or STR signal). Tuning starts.

**NOTES**

When selecting offline auto tuning performed with motor running (Pr. 96 Auto tuning setting/status = "101"), caution must be taken since the motor runs.

To force tuning to end, use the MRS or RES signal or press the STOP/RESET key of the operation panel. (Turning the start signal (STF signal or STR signal) off also ends tuning.)

During offline auto tuning, only the following I/O signals are valid: (initial value)

– Input terminal:

STOP, OH, MRS, RT, CS, RES, STF and STR

– Output terminal:

RUN, OL, IPF, CA, AM, A1, B1 and C1

Note that the progress status of offline auto tuning is output from AM and CA when speed and output frequency are selected.

Since the RUN signal turns on when tuning is started, caution is required especially when a sequence which releases a mechanical brake by the RUN signal has been designed.

When executing offline auto tuning, input the run command after switching on the main circuit power (R/L1, S/L2, T/L3) of the inverter.

Do not perform ON/OFF switching of the second function selection signal (RT) during execution of offline autotuning. Auto tuning is not executed properly.

Setting offline auto tuning (Pr. 96 Auto tuning setting/status = "1 or 101") will make pre-excitation invalid

**Display during tuning**

Monitor is displayed on the operation panel and parameter unit (FR-PU04/FR-PU07) during tuning as shown below..

	Parameter Unit (FR-PU04/FR-PU07) Display		Operation Panel (FR-DU07) Indication	
	1	101	1	101
Setting				
Tuning in progress				
Normal end				
Error end (when inverter protective function operation is activated)				

**Tab. 6-50:** Display during tuning (monitor display)

Offline Auto Tuning Setting	Time
Non-rotation mode (Pr. 96 = 1)	Approximately 25 to 120s (Tuning time differs according to the inverter capacity and motor type.)
Rotation mode (Pr. 96 = 101)	Approximately 40s (Offline auto tuning time varies with the acceleration and deceleration time settings as indicated below. Offline auto tuning time = acceleration time + deceleration time + approx. 30s)

**Tab. 6-51:** Offline auto tuning time (when the initial value is set)

**Return to normal operation**

When offline auto tuning ends, press the STOP/RESET key of the operation panel during PU operation. For external operation, turn off the start signal (STF signal or STR signal) once. This operation resets the offline auto tuning and the PU's monitor display returns to the normal indication. (Without this operation, next operation cannot be started.)

**NOTE**

Do not change the Pr. 96 setting after completion of tuning (3 or 103). If the Pr. 96 setting is changed, tuning data is made invalid and tuning must be performed again.

If offline auto tuning ended in error (see the table below), motor constants are not set. Perform an inverter reset and restart tuning.

Pr. 96 Setting	Error Cause	Remedy
8	Forced end	Set "1" or "101" in Pr. 96 and perform tuning again.
9	Inverter protective function operation	Make setting again.
91	Current limit (stall prevention) function was activated.	Increase acceleration/deceleration time. Set "1" in Pr. 156.
92	Converter output voltage reached 75% of rated value.	Check for fluctuation of power supply voltage.
93	– Calculation error – A motor is not connected.	Check the motor wiring and make setting again.

**Tab. 6-52: Settings for parameter 96**

When tuning is ended forcibly by pressing the STOP/RESET key or turning off the start signal (STF or STR) during tuning, offline autotuning does not end normally. (The motor constants have not been set.) Perform an inverter reset and restart tuning.

#### NOTES

The motor constants measured once in the offline auto tuning are stored as parameters and their data are held until the offline auto tuning is performed again.

An instantaneous power failure occurring during tuning will result in a tuning error. After power is restored, the inverter goes into the normal operation mode. Therefore, when STF (STR) signal is on, the motor runs in the forward (reverse) rotation.

Any alarm occurring during tuning is handled as in the ordinary mode. Note that if a fault retry has been set, retry is ignored.

The set frequency monitor displayed during the offline auto tuning is 0Hz.



#### CAUTION:

- **Note that the motor may start running suddenly.**
- **When the offline auto tuning is used in vertical lift application, e.g. a lifter, it may drop due to insufficient torque.**

**Utilizing or changing offline auto tuning data for use**

The data measured in the offline auto tuning can be read and utilized or changed.

① Set Pr. 71 according to the motor used.:

Motor		Pr. 71 ①
Mitsubishi standard motor, Mitsubishi high efficiency motor	SF-JR	4
	SF-JR 4P (1.5kW or less)	24
	SF-HR	44
	Others	4
Mitsubishi constant-torque motor	SF-JRCA 4P, SF-TH (constant torque)	14
	SF-HRCA 4P	54
	Others (SF-JRC, etc.)	14
Vector control dedicated motor	SF-V5RU, SF-THY	34
Other manufacturer's standard motor	—	4
Other manufacturer's constant-torque motor	—	14

**Tab. 6-53: Motor selection**

① For other settings of Pr. 71, refer to section 6.12.2.

② In the parameter setting mode, read the following parameters and set desired values.

Parameter	Name	Setting Range	Setting Increments	Initial Value
82	Motor excitation current	0-****,9999	1	9999
90	Motor constant R1	0-****,9999	1	9999
91	Motor constant R2	0-****,9999	1	9999
92	Motor constant L1	0-****,9999	1	9999
93	Motor constant L2	0-****,9999	1	9999
94	Motor constant X	0-****,9999	1	9999
859	Torque current	0-****,9999	1	9999

**Tab. 6-54: Parameter setting ranges**

**NOTES**

The display units of the motor constants read using Pr. 684 Tuning data unit switchover can be changed. Note that parameter values can not be changed.

Pr. 684	Pr. 82, Pr. 455	Pr. 90, Pr. 458	Pr. 91, Pr. 459	Pr. 92, Pr. 460	Pr. 93, Pr. 461	Pr. 94, Pr. 462	Pr. 859, Pr. 860
0	Internal data converted value						
1	01800 or less	0.01A	0.001Ω	0.001Ω	0.1mH	0.1mH	0.01A
	02160 or more	0.1A	0.01mΩ	0.01mΩ	0.01mH	0.01mH	0.1A

When "9999" is set in Pr. 90 to Pr. 94 , Mitsubishi motor (SF-JR, SF-HR,SF-JRCA, SF-HRCA) constants are used.

As the motor constants measured in the offline auto tuning have been converted into internal data (\*\*\*\*), refer to the following setting example when making setting:

Setting example:

To slightly increase Pr. 90 value (5%)

When Pr. 90 is displayed as "2516", set 2642, i.e.  $2516 \times 1.05 = 2641.8$ , in Pr. 90.

(The value displayed has been converted into a value for internal use. Hence, simple addition of a given value to the displayed value has no significance.)

**Method to set the motor constants without using the offline auto tuning data**

The Pr. 90 and Pr. 94 motor constants may either be entered in [Ω, mΩ] or in [mH]. Before starting operation, confirm which motor constant unit is used.

**To enter the Pr. 90 to Pr. 94 motor constants in [Ω]/[mΩ]**

① Set Pr. 71 according to the motor used:

	Star Connection Motor	Delta Connection Motor
Standard motor	5	6
Constant-torque motor	15	16

**Tab. 6-55: Setting of parameter 71**

② In the parameter setting mode, read the following parameters and set desired values.

$I_q$  = torque current,  $I_{100}$  = rated current,  $I_0$  = no load current

$$I_q = \sqrt{I_{100}^2 + I_0^2}$$

Pr.	Name	Setting Range		Setting Increments	Initial Value
82	Motor excitation current (no load current)	01800 or less	0–500A, 9999	0.01A	9999
		02160 or more	0–3600A, 9999	0.1A	
90	Motor constant R1	01800 or less	0–50Ω, 9999	0.001Ω	9999
		02160 or more	0–400mΩ, 9999	0.01mΩ	
91	Motor constant R2	01800 or less	0–50Ω, 9999	0.001Ω	9999
		02160 or more	0–400mΩ, 9999	0.01mΩ	
92	Motor constant L1	01800 or less	0–50Ω, 9999	0.001Ω	9999
		02160 or more	0–3600mΩ, 9999	0.01mΩ	
93	Motor constant L2	01800 or less	0–50Ω, 9999	0.001Ω	9999
		02160 or more	0–3600mΩ, 9999	0.01mΩ	
94	Motor constant X	01800 or less	0–500Ω, 9999	0.01Ω	9999
		02160 or more	0–100Ω, 9999		
859	Torque current	01800 or less	0–500A, 9999	0.01A	9999
		02160 or more	0–3600A, 9999	0.1A	

**Tab. 6-56: Setting of parameter 82, 90 to 94 and 859**

③ Refer to the following table and set Pr. 83 and Pr. 84.

Pr.	Name	Setting Range	Setting Increments	Initial Value
83	Motor rated voltage	0–1000V	0.1V	400V
84	Rated motor frequency	10–120Hz	0.01Hz	50Hz

**Tab. 6-57: Setting of parameter 83 and 84**

**NOTES**

When "9999" is set in Pr. 90 to Pr. 94, Mitsubishi motor (SF-JR, SF-HR, SF-JRCA, SF-HRCA) constants are used.

If "star connection" is mistaken for "delta connection" or vice versa during setting of Pr. 71, advanced magnetic flux vector control, real sensorless vector control and vector control cannot be exercised properly



**To enter the Pr. 90 and Pr. 94 motor constants in [mH]**

① Set Pr. 71 according to the motor used:

Motor		Pr. 71 ①
Mitsubishi standard motor, Mitsubishi high efficiency motor	SF-JR	0
	SF-JR 4P-1,5 kW oder kleiner	20
	SF-HR	40
Mitsubishi constant-torque motor	SF-JRCA 4P, SF-TH (constant-torque)	1
	SF-HRCA 4P	50
Vector control dedicated motor	SF-V5RU	30

**Tab. 6-58: Motor selection**

① For other settings of Pr. 71, refer to section 6.12.2.

② In the parameter setting mode, read the following parameters and set desired values. Calculate the Pr. 94 value from the following formula.

$$\text{Pr. 94} = \left( 1 + \frac{M^2}{L1 \times L2} \right) \times 100 [\%]$$

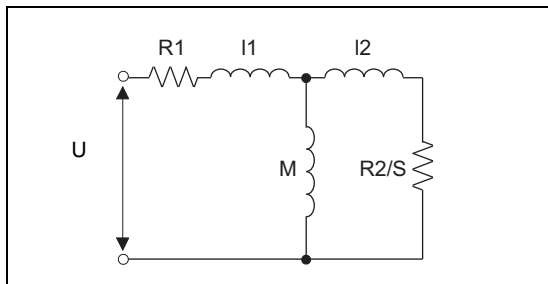

**Fig. 6-94:**  
Motor equivalent circuit diagram

1001556E

- R1: Primary resistance
- R2: Secondary resistance
- l1: Primary leakage inductance
- l2: Secondary leakage inductance
- M: Excitation inductance
- S: Slip
- L1 = l1 + M: Primary inductance
- L2 = l2 + M: Secondary inductance

Pr.	Name	Setting Range		Setting Increments	Initial Value
82	Motor excitation current (no load current)	01800 or less	0–500A, 9999	0.01A	9999
		02160 or more	0–3600A, 9999	0.1A	
90	Motor constant R1	01800 or less	0–50Ω, 9999	0.001Ω	9999
		02160 or more	0–400mΩ, 9999	0.01mΩ	
91	Motor constant R2	01800 or less	0–50Ω, 9999	0.001Ω	9999
		02160 or more	0–400mΩ, 9999	0.01mΩ	
92	Motor constant L1	01800 or less	0–50Ω, 9999	0.001Ω	9999
		02160 or more	0–3600mΩ, 9999	0.01mΩ	
93	Motor constant L2	01800 or less	0–50Ω, 9999	0.001Ω	9999
		02160 or more	0–3600mΩ, 9999	0.01mΩ	
94	Motor constant X	01800 or less	0–500Ω, 9999	0.01Ω	9999
		02160 or more	0–100Ω, 9999		
859	Torque current	01800 or less	0–500A, 9999	0.01A	9999
		02160 or more	0–3600A, 9999	0.1A	

**Tab. 6-59:** Setting of parameter 82, 90 to 94 and 859

③ Refer to the following table and set Pr. 83 and Pr. 84.

Pr.	Name	Setting Range	Setting Increments	Initial Value
83	Motor rated voltage	0–1000V	0.1V	400V
84	Rated Motor Frequency	10–120Hz	0.01Hz	50Hz

**Tab. 6-60:** Setting of parameter 83 and 84

**NOTE**

When "9999" is set in Pr. 90 to Pr. 94, Mitsubishi motor (SF-JR, SF-HR, SF-JRCA, SF-HRCA) constants are used.

**Tune second applied motor**

- When you want to switch two motors with one inverter, set the second motor in Pr. 450 "Second applied motor" (refer to section 6.12.2). Initial setting is without second applied motor.
- Turning the RT signal on makes the following parameters for the second parameters valid.

Function	RT Signal ON (second motor)	RT Signal OFF (first motor)
Motor capacity	Pr. 453	Pr. 80
Number of motor poles	Pr. 454	Pr. 81
Motor excitation current	Pr. 455	Pr. 82
Motor rated voltage	Pr. 456	Pr. 83
Rated motor frequency	Pr. 457	Pr. 84
Motor constant (R1)	Pr. 458	Pr. 90
Motor constant (R2)	Pr. 459	Pr. 91
Motor constant (L1)	Pr. 460	Pr. 92
Motor constant (L2)	Pr. 461	Pr. 93
Motor constant (X)	Pr. 462	Pr. 94
Auto tuning setting/status	Pr. 463	Pr. 96

**Tab. 6-61:** Validation of parameters by the RT signal

**NOTES**

The RT signal is assigned to the terminal RT in the initial setting. By setting "3" in any of Pr. 178 to Pr. 189 (input terminal function selection), you can assign the RT signal to the other terminal.

Changing the terminal assignment using Pr. 178 to Pr. 189 "Input terminal function selection" may affect other functions. Make setting after confirming the function of each terminal.

**6.12.4 Online auto tuning (Pr. 95, Pr. 574)** Magnetic flux Sensorless Vector

When online auto tuning is selected under advanced magnetic flux vector control, real sensorless vector control or vector control, excellent torque accuracy is provided by temperature compensation even if the secondary resistance value of the motor varies with the rise of the motor temperature.

Pr. No.	Name	Initial Value	Setting Range	Description	Parameters referred to	Refer to Section
<b>95</b>	Selbsteinstellung der Betriebsmotordaten	0	0	Keine Selbsteinstellung	9 Electronic thermal O/L relay	6.12.1
			1	Selbsteinstellung beim Start	71 Applied motor	6.12.2
			2	Selbsteinstellung mit Beobachter für Magnetfluss (normale Selbsteinstellung)	80 Motor capacity 81 Number of motor poles	6.12.4 6.12.4
<b>574</b>	Selbsteinstellung der Betriebsmotordaten (Motor 2)	0	0/1	Selbsteinstellung der Betriebsmotordaten für den 2. Motor (die Einstellungen entsprechen denen von Pr. 95)	96 Auto tuning setting/status 178-189 Input terminal function selection 190-196 Output terminal function selection	6.12.3 6.14.1 6.14.5

**Start-time online auto tuning (Pr. 95 = 1)**

- By quickly tuning the motor constants at a start, high accuracy operation unaffected by the motor temperature and stable operation with high torque down to ultra low speed can be performed.
- Make sure advanced magnetic flux vector control (Pr. 80, Pr. 81 ), real sensorless vector control or vector control (Pr.800 ) is selected.
- Before performing online auto tuning, perform offline auto tuning (Pr. 96) without fail.

**Operation method**

- ① Refer to section 6.12.3 to perform offline auto tuning.
- ② Check that "3" or "103" (offline auto tuning completion) is set in Pr. 96 "Auto tuning setting/status".
- ③ Set "1" (start-time online auto tuning) in Pr. 95 "Online auto tuning selection". Online auto tuning is performed from the next starting.
- ④ Before starting operation, check that the following parameters have been set.

Pr.	Description
9	Used as rated motor current and electronic thermal relay parameters.
71	Applied motor
80	Motor capacity (down to one rank lower than the inverter capacity, note that the capacity should be 0.4kW to 55kW)
81	Number of motor poles

**Tab. 6-62:** Related Parameters

- ⑤ Press the RUN key of the operation panel or the FWD or REV key of the parameter unit (FR-PU04/FR-PU07). For external operation, turn on the run command (STF or STR signal).

**NOTE**

For using start-time online auto tuning in elevator, examine the utilization of a brake sequence for the brake opening timing at a start. Though the tuning ends in about a maximum of 500ms after a start, torque is not provided fully during that period. Therefore, note that there may be a possibility of drop due to gravity. It is recommended to perform tuning using a start time tuning signal (X28) (please refer also to page 6-237).

**Magnetic flux observer (normal tuning, Pr. 95 = 2)**

- When exercising vector control using a motor with encoder, it is effective for torque accuracy improvement. The current flowing in the motor and the inverter output voltage are used to estimate/observe the magnetic flux in the motor.

The magnetic flux of the motor is always detected with high accuracy so that an excellent characteristic is provided regardless of the change in the temperature of the secondary resistance.

- Vector control (Pr. 80, Pr. 81, Pr. 800) should be selected (refer to section 6-70).

**NOTE**

For the SF-JR (with encoder), SF-HR (with encoder), SF-JRCA (with encoder) or SF-HRCA (with encoder), it is not necessary to perform offline auto tuning to select adaptive magnetic flux observer. (Note that it is necessary to perform offline auto tuning (non-rotation mode) for the wiring length resistance to be reflected on the control when the wiring length is long (30m or longer as reference).

**NOTES**

Online auto tuning does not operate if the MRS signal is input, if the preset speed is less than the Pr. 13 "Starting frequency" (V/f control or advanced magnetic flux vector control), or if the starting conditions of the inverter are not satisfied, e.g. inverter error.

Online auto tuning does not operate during deceleration or at a restart during DC brake operation.

Online auto tuning is invalid for jog operation.

Automatic restart after instantaneous power failure overrides when automatic restart after instantaneous power failure is selected. (Start-time online auto tuning is not performed at frequency search.)

Perform online auto tuning at a stop with the X28 signal when using automatic restart after instantaneous power failure together. (Refer to the following for details.)

Zero current detection and output current detection are valid during online auto tuning.

The RUN signal is not output during online auto tuning. The RUN signal turns on at a start.

If the period from an inverter stop to a restart is within 4s, start-time tuning is performed but the tuning results are not reflected.

### Start-time online auto tuning from external terminal (X28 signal, Y39 signal)

- By turning on the start-time tuning signal (X28) before the start signal (STF or STR) turns on (at a stop), online tuning is performed and a starting delay after start signal turns on due to tuning can be avoided.

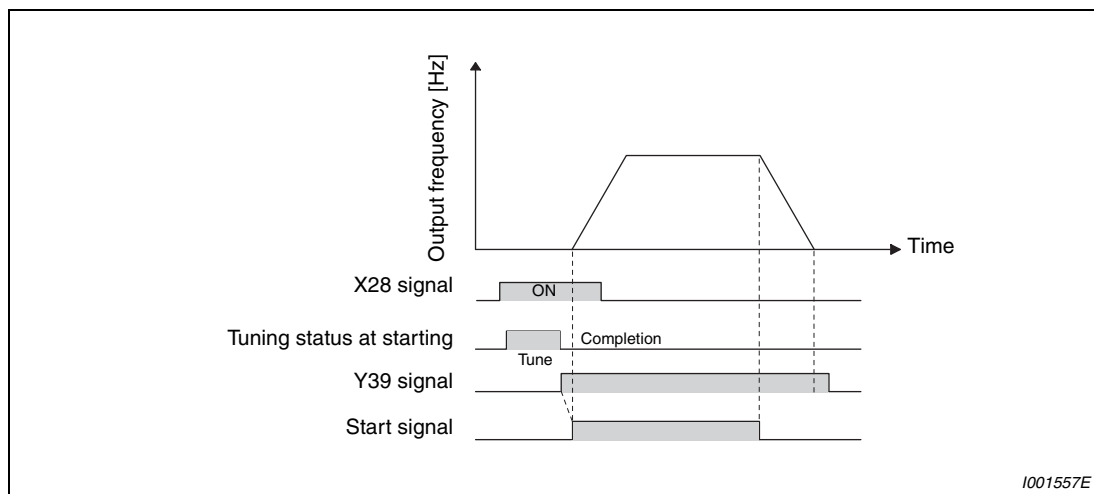

**Fig. 6-95:** Start of online auto tuning using an external signal

- Perform offline auto tuning and set "1" (start-time tuning) in Pr. 95.
- When the start-time tuning completion signal (Y39) is off, start-time tuning with the X28 signal is performed.
- Start-time tuning ends within 500ms maximum.
- When using the X28 signal, set "28" in Pr. 178 to Pr. 189 (input terminal function selection) and assign functions to the input terminal.
- When using the Y39 signal, set "39 (source logic) or 139 (sink logic)" in Pr. 190 to Pr. 196 (output terminal function selection) and assign functions to the output terminal.

#### NOTES

Start-time tuning is performed when the start signal is turned on during zero speed control also.

The Y39 signal is in on status while secondary magnetic flux exists after the motor stop.

While the Y39 signal is on, the X28 signal is not valid.

The STF, STR signals are valid after completion of the start-time tuning.

Only the following output signals are valid during tuning:  
IPF, THP, PU, Y12, RY, ER, LF, MT, CA, AM, A1, B1, C1, A2, B2, and C2.

Tuning is invalid during V/f control.

Changing the terminal assignment using Pr. 178 to Pr. 189 (input terminal function selection) or Pr. 190 to Pr. 196 (output terminal function selection) may affect the other functions. Make setting after confirming the function of each terminal.

**Tune second applied motor**

- When you want to switch two motors with one inverter, set the second motor in Pr. 450 Second applied motor (refer to section 6.12.2). Initial setting is without second applied motor.

Perform tuning using Pr. 574 Second motor online auto tuning. Pr. 574 is made valid when the RT signal turns on.

Parameter number	Description
51	Used as rated motor current and electronic thermal relay parameters.
450	Applied motor
453	Motor capacity (down to one rank lower than the inverter capacity, note that the capacity should be 0.4kW or more)
454	Number of motor poles

**Tab. 6-63:** Related Parameters

**NOTES**

The RT signal acts as the second function selection signal and makes the other second functions valid.

The RT signal is assigned to the terminal RT in the initial setting. By setting "3" in any of Pr. 178 to Pr. 189 (input terminal function selection), you can assign the RT signal to the other terminal.

Changing the terminal assignment using Pr. 178 to Pr. 189 (input terminal function selection) may affect the other functions. Make setting after confirming the function of each terminal.



## 6.13 Motor brake and stop operation

Purpose	Parameters that must be set		Refer to Section
Motor braking torque adjustment	DC injection brake and zero speed control, servo lock	Pr. 10 to Pr. 12, Pr. 802, Pr. 850	6.13.1
Improve the motor braking torque with an option	Selection of a regenerative brake	Pr. 30, Pr. 70	6.13.2
Performing operation by DC current input	DC current feeding mode	Pr. 30	6.13.2
Coast the motor to a stop	Selection of motor stopping method	Pr. 250	6.13.3
Used to stop the motor with a mechanical brake (vibration restraint at stop-on-contact)	Stop-on-contact control	Pr. 270, Pr. 275, Pr. 276	6.13.4
Used to stop the motor with a mechanical brake (operation timing of a mechanical brake)	Brake sequence function	Pr. 278 to Pr. 285, Pr. 292	6.13.5
Perform position stop (orientation) control of the rotation shaft	Orientation control	Pr. 350 to Pr. 366, Pr. 369, Pr. 393, Pr. 396 to Pr. 399	6.13.6

### 6.13.1 DC injection brake and zero speed control, servo lock (LX signal, X13 signal, Pr. 10 to Pr. 12, Pr. 802, Pr. 850)

The FR-A700 EC frequency inverter has an adjustable DC brake function.

The DC injection brake can be operated at a motor stop to adjust the stop timing and braking torque. Zero speed control can be selected during real sensorless vector control and either zero speed control or servo lock can be selected under vector control. In DC injection brake operation, DC voltage is directly applied to the motor to prevent the motor shaft from rotating when a motor decelerates to stop. While, in zero speed control, vector control is performed to maintain 0r/min. In either control, the motor will not return to the original position if the motor shaft rotates due to external force.

The motor shaft position is maintained with servo lock. The motor will return to the original position if the motor shaft rotates due to external force.

Pr. No.	Name	Initial Value	Setting Range	Description
<b>10</b>	DC injection brake operation frequency	3Hz	0 to 120 Hz	Set the operation frequency of the DC injection brake.
			9999	Operated at Pr. 13 or less.
<b>11</b>	DC injection brake operation time	0.5s	0	DC injection brake (zero speed control) disabled
			0.1 to 10s	Set the operation time of the DC injection brake (zero speed control, servo lock).
			8888	Operate when X13 signal is on.
<b>12</b>	DC injection brake operation voltage	00250 or less	4%	0 to 30% Set the DC injection brake voltage (torque). When "0" is set, DC injection brake is disabled.
		00310 to 01800	2%	
		02160 or more	1%	
<b>802</b>	Pre-excitation selection ①	0	0	Zero speed control
			1	Servo lock
<b>850</b>	Brake operation selection	0	0	DC injection brake operation
			1	Zero speed control
			2	Magnetic flux decay output shutoff

Parameters referred to	Refer to Section
13 Starting frequency	6.11.2
71 Applied motor	6.12.2
178-189 Input terminal function selection	6.14.1
422 Position loop gain	6.5.6

① This parameter can be set when the FR-A7AP (option) is mounted.

**Operation frequency setting (Pr. 10)**

When the frequency at which the DC injection brake operates is set to Pr. 10, the DC injection brake is operated when this frequency is reached during deceleration.

At the Pr. 10 setting of "9999", the DC injection brake is operated when deceleration is made to the frequency set in Pr. 13 "Starting frequency".

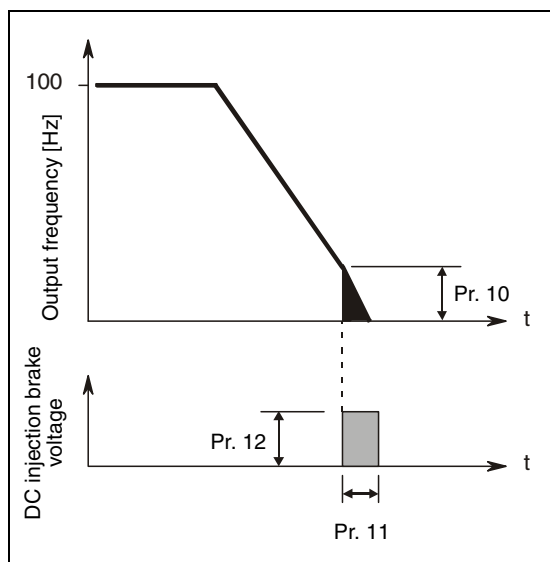

**Fig. 6-96:**  
When Pr. 11 is set to a value between 0.1 and 10s

1000007C

**NOTES**

Performing pre-excitation (zero speed control) under real sensorless vector may cause motor vibration, etc. at deceleration to stop. To prevent this, set Pr.10 DC injection brake operation frequency to 0.5Hz or less.

The initial value of Pr. 10 automatically changes to 0.5Hz during vector control.

### Operation time setting (Pr. 11)

Use Pr. 11 to set the duration period the DC injection brake is applied.

When Pr. 11 = 0s, the DC injection brake is not operated. (At a stop, the motor coasts.)

When Pr. 11 = "8888", the DC injection brake (zero speed control, servo lock) is applied when X13 signal is turned on. For the terminal used for X13 signal input, set "13" in any of Pr. 178 to Pr. 189 to assign the function.

When the motor does not stop due to large load moment (J), increasing the setting produces an effect.

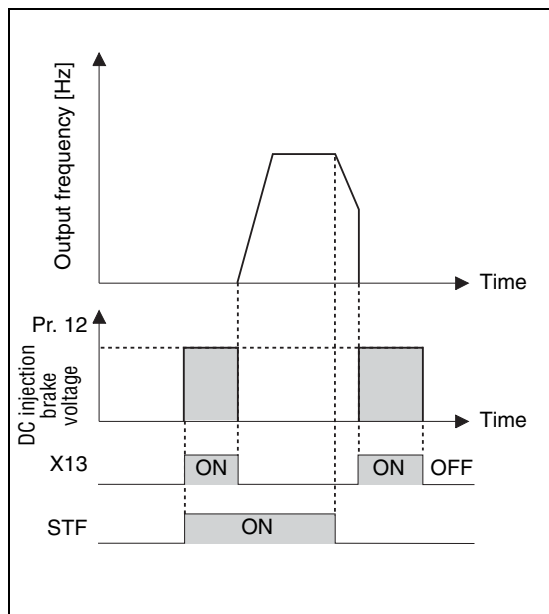

**Fig. 6-97:**  
When Pr. 11 is set to „8888“

1001559E

#### NOTES

When the X13 signal is turned on with Pr. 11 = "8888", zero speed control is activated regardless of setting of Pr. 850 "Brake operation selection."

Under vector control, zero speed control or servo lock is activated depending on the Pr. 802 setting.

**Operation voltage (torque) setting (Pr. 12)**

Use Pr. 12 to set the percentage to the power supply voltage. (This parameter is not used during zero speed control or servo lock.)

When Pr. 12 = 0%, the DC injection brake is not operated. (At a stop, the motor coasts.)

When using the constant-torque motor (SF-JRCA) and energy saving motor (SF-HR, SF-HRCA), change the Pr.12 setting as follows:

Constant-torque motor (SF-JRCA):	00126 or less ... 4 %
	00170 to 01800 ... 2 %
Energy saving motor SF-HR, SF-HRCA:	00126 or less ... 4 %
	00170 and 00250 ... 3 %
	00310 to 01800 ... 2 % (00770 ... 1,5 %)

**NOTE**

For the 00170 and 00250, when the Pr. 12 setting is as below, changing the Pr. 71 "Applied motor" setting changes the Pr. 12 setting automatically, it is not necessary to change the Pr. 12 setting.

**Parameter 12 = 4% (initial value)**

The Pr. 12 setting is automatically changed to 2% if the Pr. 71 value is changed to from the value selecting the standard motor (0, 2 to 8, 20, 23, 24, 40, 43, 44) to the value selecting the constant motor (1, 13 to 18, 50, 53, 54).

**Parameter 12 = 2%**

The Pr. 12 setting is automatically changed to 4% if the Pr. 71 value is changed from the value selecting the constant motor (1, 13 to 18, 50, 53, 54) to the value selecting the standard motor (0, 2 to 8, 20, 23, 24, 40, 43, 44).

**Brake operation selection during real sensorless vector control (Pr. 850)**

You can select DC injection brake (initial value), zero speed control or magnetic flux decay output shut off for brake operation during real sensorless vector control.

When Pr. 850 = "1", zero speed control is exercised when the frequency reaches or decreases below the frequency set in Pr. 10.

**NOTES**

When the X13 signal is on with Pr. 11 = "8888", zero speed control is activated regardless of setting of Pr. 850 Brake operation selection.

When restarting from brake operation during real sensorless vector control, set "1" (zero speed control) in Pr. 850. When the setting value is "0" (DC injection brake), it may take approx. 2s until frequency is actually output from when the start command is input.

When pre-excitation is performed, select zero speed control or servo lock using Pr. 802.

Pr. 802	Pre-excitation	Description
0 (initial value)	Zero speed control	Even under load, an attempt is made to maintain 0r/min to keep the motor shaft stopped. Note that if the shaft is overcome and turned by external force, it does not return to the original position. Position control is not exercised and only speed control is carried out to perform operation.
1	Servo lock	Even under load, an attempt is made to maintain the motor shaft position. Note that if the shaft is turned by external force, it returns to the original position after the external force has gone away. Since position control is exercised, you can adjust this position loop gain using Pr. 422 "Position loop gain".

**Tab. 6-64:** Selection of pre-excitation

The relationship between the DC injection brake operation and pre-excitation operation under each control is shown in the following table.

Control Method	Control Mode	Pr. 802	Pr. 850	Decelerates to Stop	LX: ON	X13: ON (Pr. 11 = 8888)
V/f control	—	—	—	DC Injection brake	—	DC Injection brake
Advanced magnetic flux-vector control						
Real sensor-less vector control	Speed	—	0	DC Injection brake	Zero speed	Zero speed
		—	1	Zero speed		
		—	2	Magnetic flux decay output shut off		
	Torque	—	0	DC Injection brake	Zero speed	Zero speed
		—	1	Zero speed		
		—	2	Magnetic flux decay output shut off		
Vector control	Speed	0	—	Zero speed	Zero speed	Zero speed
		1	—	Servo lock	Servo lock	Servo lock
	Torque	0	—	Zero speed	Zero speed	Zero speed
		1	—	Servo lock	Servo lock	Servo lock
	Position	—	—	—	Servo lock	—

**Tab. 6-65:** Relationship between the DC injection brake operation and pre-excitation operation under each control.

● Magnetic flux decay output shutoff function (Pr. 850 = "2")

Performing frequent start/stop (inching operation) during Real sensorless vector control may cause an inverter fault (electronic thermal relay function fault such as E.THT) or an error in monitor output (running speed, motor torque, load meter, torque command, torque current command, and motor output) due to residual magnetic flux in the motor.

In such a case, use the magnetic flux decay output shutoff function for decaying the motor residual magnetic flux and shutting off the output.

- Set the magnetic flux decay output shutoff function (Pr. 850 = "2") to shut off the output after decaying the motor residual magnetic flux during Real sensorless vector control.
- Turning OFF the start command decelerates the speed. Then, when an estimated speed is lower than Pr. 10 "DC injection brake operation frequency", the inverter starts the magnetic flux decay output shutoff function.
- When using brake sequence, the inverter starts the magnetic flux decay output shutoff function at 0.5Hz or Pr.13 "Starting frequency" (whichever is lower) during deceleration.
- During magnetic flux decay output shutoff, the torque decreases. Set a mechanical brake to be activated during magnetic flux decay output shutoff.
- When a MC is provided on the inverter output side, open the MC after magnetic flux decay processing time (refer to the following figures) has passed.
- The magnetic flux decay output shutoff function is stopped at restart or when turning ON the Pre-excitation signal (LX)/External DC injection brake operation start signal (X13).

**NOTES**

The magnetic flux decay output shutoff function is available for frequency inverters of the FR-A700 EC series manufactured in December 2010 or later (refer to section 1.2).

Regardless of the Pr. 850 setting, turning ON the X74 (magnetic flux decay output shutoff signal) starts the magnetic flux decay output shutoff.

The inverter output voltage shutoff timing during normal operation and during brake sequence is shown in the following figures.

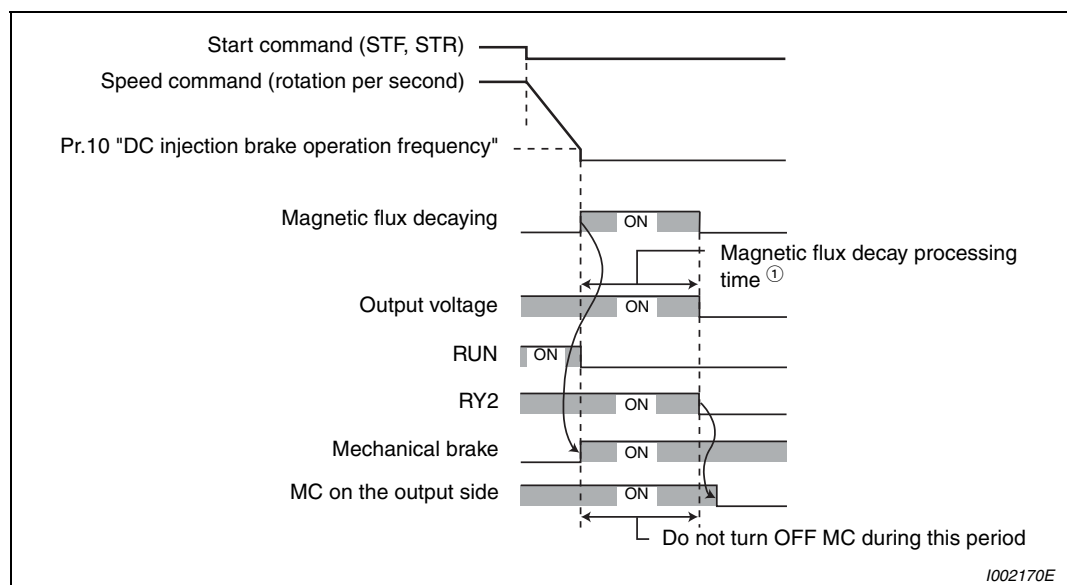

**Fig. 6-98:** Inverter output voltage shutoff timing during normal operation

① The maximum time for magnetic flux decaying (see table below).

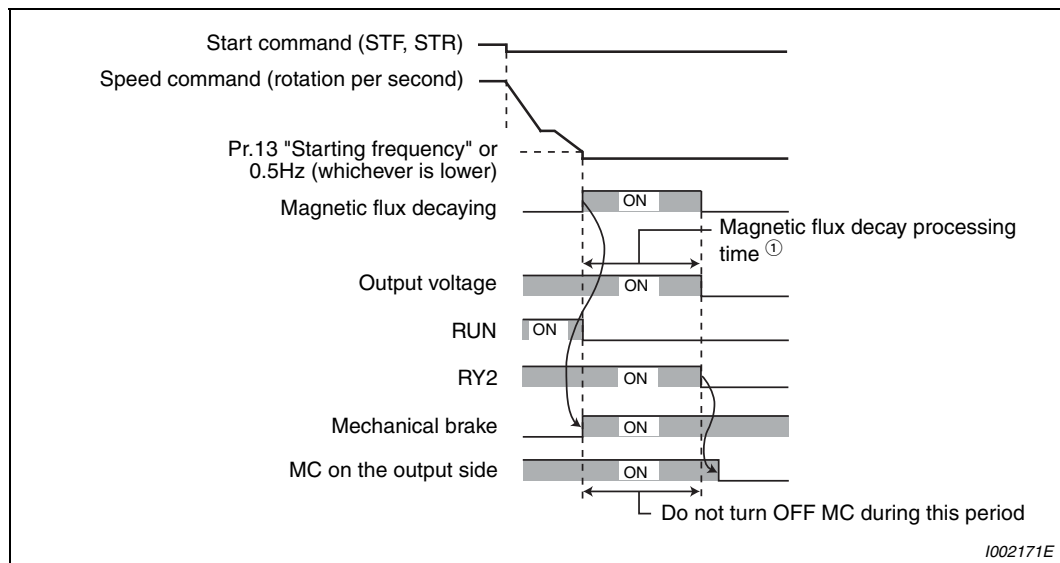

**Fig. 6-99:** Inverter output voltage shutoff timing during brake sequence

① The maximum time for magnetic flux decaying (see table below).

The following table shows the relationship between the motor capacity and the magnetic flux decay processing time.

Motor Capacity (Pr. 80 setting)	≥2.2kW	3.7kW to 11kW	15kW to 30kW	37kW to 55kW	≤75kW
Magnetic flux decay processing time	250ms	500ms	800ms	900ms	1100ms

**Tab. 6-66:** Magnetic flux decay processing times

**NOTES**

When some other factor affecting output shutoff (such as inverter fault or MRS signal ON) occurs during the magnetic flux decay output shutoff function, the magnetic flux decay output shutoff function is immediately stopped and shuts off the output.

To operate the magnetic flux decay output shutoff function by turning ON the X74 signal, set "74" in any of Pr. 178 to Pr. 189 (input terminal function selection) to assign the function. Changing the terminal assignment using Pr. 178 to Pr. 189 (input terminal function selection) may affect the other functions. Make setting after confirming the function of each terminal.



**CAUTION:**

- Voltage is output during magnetic flux decay processing. Take caution to avoid an electrical shock.
- If the timing of mechanical brake opening is early, motor shaft may be forced to turn by a gravity drop or external force.  
If the timing of mechanical brake opening is late, overcurrent, stall prevention operation or electronic thermal relay function may be activated.  
Use output frequency detection signal (FU) or output current detection signal (Y12) to perform the mechanical brake opening suitable for the machine.

### Pre-excitation signal (LX signal)

When the LX signal is turned on under real sensorless vector control or vector control, pre-excitation (zero speed control or servo lock) is exercised during a stop.

For the terminal used for LX signal input, set "23" in any of Pr. 178 to Pr. 186 to assign the function.

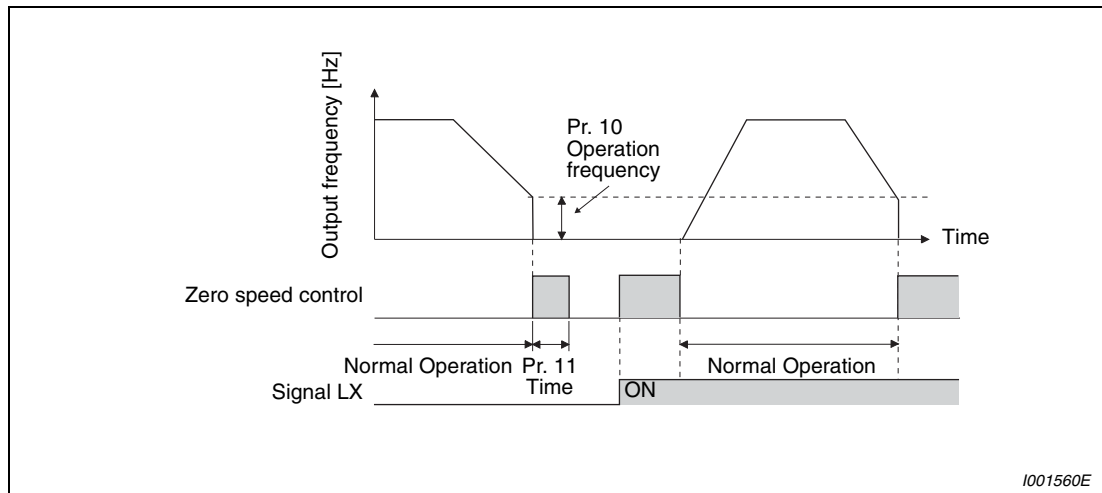

Fig. 6-100: Selection of pre-excitation using an external signal

#### NOTE

Changing the terminal assignment using Pr. 178 to Pr. 189 (input terminal function selection) may affect the other functions. Make setting after confirming the function of each terminal.



#### CAUTION:

- **Performing pre-excitation (LX signal and X13 signal) under torque control (real sensorless vector control) may start the motor running at a low speed even when the start command (STF or STR) is not input. The motor may run also at a low speed when the speed limit value=0 with a start command input. Perform pre-excitation after making sure that there will be no problem in safety if the motor runs.**
- **Although FWD/REV of the operation panel is not lit during pre-excitation, note that voltage is applied to the motor.**
- **Note that when offline auto tuning (Pr. 96 "Auto tuning setting/status" = "1 or 101") is performed during pre-excitation, offline auto tuning is not executed but the motor starts.**
- **Do not set Pr. 11 to "0, 8888" and Pr. 12 to "0" under orientation operation. Otherwise, the motor will not stop properly.**
- **As stop holding torque is not produced, install a mechanical brake. After the machine stops fully and the mechanical brake is applied, switch the LX signal (pre-excitation) off.**



### 6.13.2 Selection of a regenerative brake (Pr. 30, Pr. 70)

- When making frequent starts/stops, use the optional high-duty brake resistor (FR-ABR), brake unit (BU, FR-BU, MT-BU) to increase the regenerative brake duty.
- Use a power regeneration common converter (FR-CV) or power regeneration converter (MT-RC) for continuous operation in regenerative status.  
Use a high power factor converter (FR-HC, MT-HC) to reduce harmonics, improve the power factor, or continuously use the regenerative mode.
- You can select either DC feeding mode 1 in which operation is performed with DC power (terminal P/+, N/-) or DC feeding mode 2 in which operation is performed normally with the AC power (terminal R/L1, S/L2, T/L3) and performed with DC power such as battery at occurrence of power failure.

Pr. No.	Name	Initial Value	Setting Range	Description	Parameters referred to	Refer to Section	
30	Regenerative function selection	0		<b>Regeneration unit</b>	<b>Terminal for power supply to the inverter</b>		
			0	Built-in brake resistor, without regenerative function, brake unit (FR-BU, BU type)	R/L1, S/L2, T/L3	57 Restart coasting time	6.16.1
			10		P/+, N/- (DC feeding mode 1)	178-189 Input terminal function selection	6.14.1
			20	High-duty brake resistor, brake unit (MT-BU5), power regeneration converter (MTRC)	R/L1, S/L2, T/L3 – P/+, N/- (DC feeding mode 2)	190-196 Output terminal function selection	6.14.5
			1		R/L1, S/L2, T/L3	261 Power failure stop selection	6.16.2
			11	P/+, N/- (DC feeding mode 1)			
			21	R/L1, S/L2, T/L3 – P/+, N/- (DC feeding mode 2)			
			2	High power factor converter (FR-HC, MT-HC), power regeneration common converter (FR-CV)	P/+, N/-		
70	Special regenerative brake duty	0 %	01800 or less	0-30 %	Set the %ED of the built-in brake transistor operation.		
			02160 or more	0-10 %			

**01800 or less**

Regeneration Unit	Terminal for power supply to the inverter	Pr. 30	Pr. 70	Remarks
Built-in brake (00250 or less), brake unit (FR-BU, BU)	R/L1, S/L2, T/L3	0 (initial value)	—	The regenerative brake duty is as follows: <ul style="list-style-type: none"> <li>• FR-A740–00023–00250 . . . 2 %</li> <li>• Other than the above . . . . 0 % (without built-in brake resistor)</li> </ul>
	P/+, N/-	10		
	R/L1, S/L2, T/L3 – P/+, N/-	20		
High-duty brake resistor (FR-ABR) (00620 or less)	R/L1, S/L2, T/L3	1	10 %/6 %	Change the setting according to the capacity. (00250 or less / 00310 or more)
	P/+, N/-	11		
	R/L1, S/L2, T/L3 – P/+, N/-	21		
High power factor converter (FR-HC), power regeneration common converter (FR-CV)	P/+, N/-	2	0 % (initial value)	

**Tab. 6-67:** Regeneration Unit and DC injection (01800 or less)

**02160 or more**

Regeneration Unit	Terminal for power supply to the inverter	Pr. 30	Pr. 70	Remarks
Not used	R/L1, S/L2, T/L3	0 (initial value)	—	
	P/+, N/-	10		
	R/L1, S/L2, T/L3 – P/+, N/-	20		
Power regeneration converter (MT-RC)	R/L1, S/L2, T/L3	1	0 % (initial value)	—
Brake unit (MT-BU5, BU-UFS)	R/L1, S/L2, T/L3	1	10 %	
	P/+, N/-	11		
	R/L1, S/L2, T/L3 – P/+, N/-	21		
High power factor converter (FR-HC)	P/+, N/-	2	—	

**Tab. 6-68:** Regeneration Unit and DC injection (02160 or more)

**NOTE**

Setting of Pr. 30 is required when a regeneration unit is used. Please refer to page 6-249 for details about the setting for each regeneration unit.

**When the built-in brake resistor, the brake unit (BU, FR-BU) is used**

Set "0 (initial value), 10 or 20" in Pr. 30. The Pr. 70 setting is made invalid.

At this time, the regenerative brake duty is as follows. (The built-in brake resistor is provided for the 00250 or less.)

- FR-A740-00023 to 00250 .....2 %
- Other than the above .....0 % (without built-in brake resistor)

**When using the high-duty brake resistor (FR-ABR) (00620 or less)**

Set "1, 11 or 21" in Pr. 30. Set Pr. 70 as follows.

- 00250 or less .....10 %
- 00310 or more .....6 %

**When using a brake unit (MT-BU5) and power regeneration converter (MT-RC)**

Set "1, 11 or 21" in Pr. 30.

Set "10%" in Pr. 70 when using a brake unit (MT-BU5).

Set "0%" in Pr. 70 when using a power regeneration converter (MT-RC).

**When using the high power factor converter (FR-HC, MT-HC) or power regeneration common converter (FR-CV)**

Set "2" in Pr. 30. The Pr. 70 setting is made invalid.

Use any of Pr. 178 to Pr. 189 (input terminal function assignment) to assign the following signals to the contact input terminals.

- X10 signal: FR-HC, MT-HC connection, FR-CV connection (inverter operation enable signal).

To make protective coordination with the FR-HC, MT-HC or FR-CV, use the inverter operation enable signal to shut off the inverter output. Input the RDY signal of the FR-HC, MT-HC (RDYB signal of the FR-CV).

- X11 signal: FR-HC, MT-HC connection (instantaneous power failure detection signal)

When the setting has been made to hold the mode at occurrence of an instantaneous power failure for RS-485 communication operation, use this signal to hold the mode. Input the Y1 or Y2 signal (instantaneous power failure detection signal) of the FR-HC, MT-HC.

For the terminal used for X10 or X11 signal input, assign its function by setting "10" (X10) or "11" (X11) in any of Pr.178 to Pr. 189.

**DC feeding mode 1 (Pr. 30 = 10 or 11)**

- Setting "10, 11" in Pr. 30 enables DC power supply operation.
- Leave the AC power supply connection terminal R/L1, S/L2, and T/L3 open and connect the DC power supply to terminal P/+ and N/-. Also, remove jumpers across terminal R/L1-R1/L11 and S/L2-S1/L21, and connect terminals R1/L11 and S1/L21 to terminal P/+ and N/-.

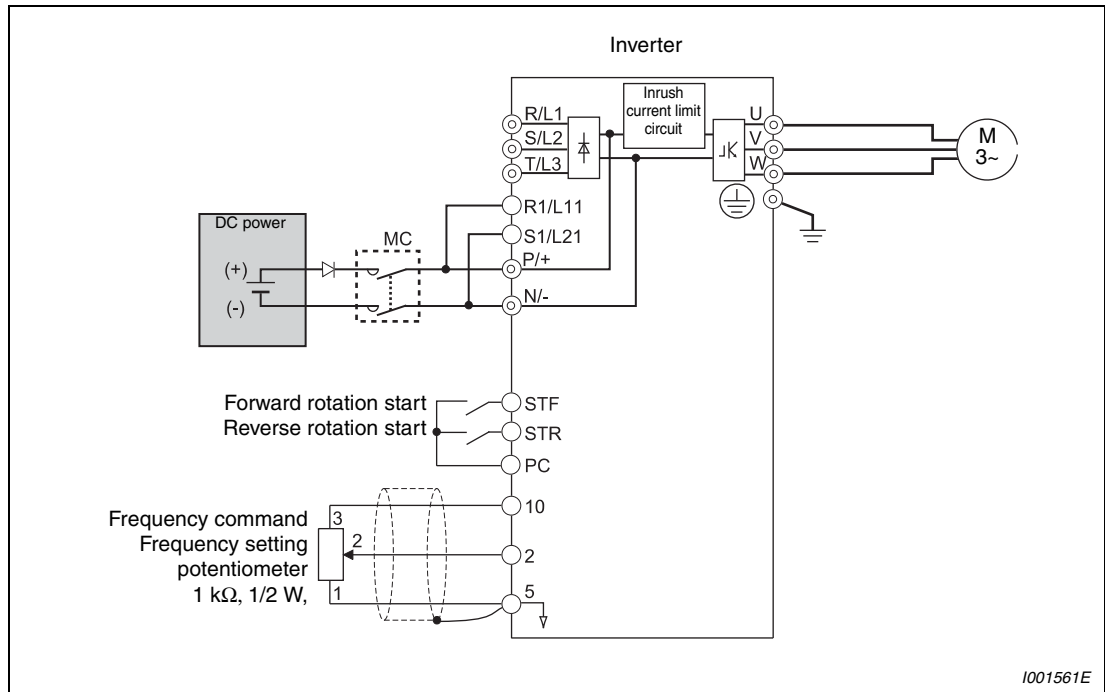

**Fig. 6-101:** Connection example for DC feeding mode 1

**DC feeding mode 2 (Pr. 30 = 20 or 21)**

- When "20 or 21" is set in Pr. 30, operation is performed with AC power normally and with DC power such as battery at power failure.
- Connect the AC power supply to terminal R/L1, S/L2, and T/L3 and connect the DC power supply to terminal P/+ and N/-. Also, remove jumpers across terminal R/L1-R1/L11 and S/L2-S1/L21, and connect terminals R1/L11 and S1/L21 to terminal P/+ and N/-. (Refer to the connection example on the next page).
- Turning on the DC feeding operation permission signal (X70) enables DC power supply operation. Refer to the table below for I/O signals.

Signal		Bezeichnung	Description	Parameter Setting
Input	X70	DC feeding operation permission signal	When performing operation with DC feeding, turn on the X70 signal. When the inverter output is shut off because of power failure, the inverter can be started in about 150ms after switching off the X70 signal then on again. (When automatic restart operation is valid, the inverter starts after additional Pr. 57 set time has elapsed.) When the X70 signal turns off during inverter operation, output is shutoff (Pr. 261 = 0) or the inverter is decelerated to a stop (Pr. 261 ≠ 0).	Set 70 in any of Pr. 178 to Pr. 189.
	X71	DC feeding cancel signal	Turn this signal on to stop DC feeding. When the X71 signal is turned on during inverter operation with turning on the X70 signal, output is shutoff (Pr. 261 = 0) or the inverter is decelerated to a stop (Pr. 261 ≠ 0), then the X85 signal turns off after the inverter stop. After turning on of the X71 signal, operation can not be performed even if the X70 signal is turned on.	Set 71 in any of Pr. 178 to Pr. 189.
Output	Y85	DC feeding signal	This signal turns on during power failure or under voltage of AC power. The signal turns off when the X71 signal turns on or power is restored. The Y85 signal does not turn off during inverter operation even if the power is restored and turns off after an inverter stop. When the Y85 signal turns on because of undervoltage, the Y85 signal does not turn off even if undervoltage is eliminated. ON/OFF status is retained at an inverter reset.	Set "85 (source logic) or 185 (sink logic)" in any of Pr. 190 to Pr. 196

**Tab. 6-69:** I/O signals for DC feeding mode 2

The following shows the connection diagram when switching to a DC power using inverter power failure detection..

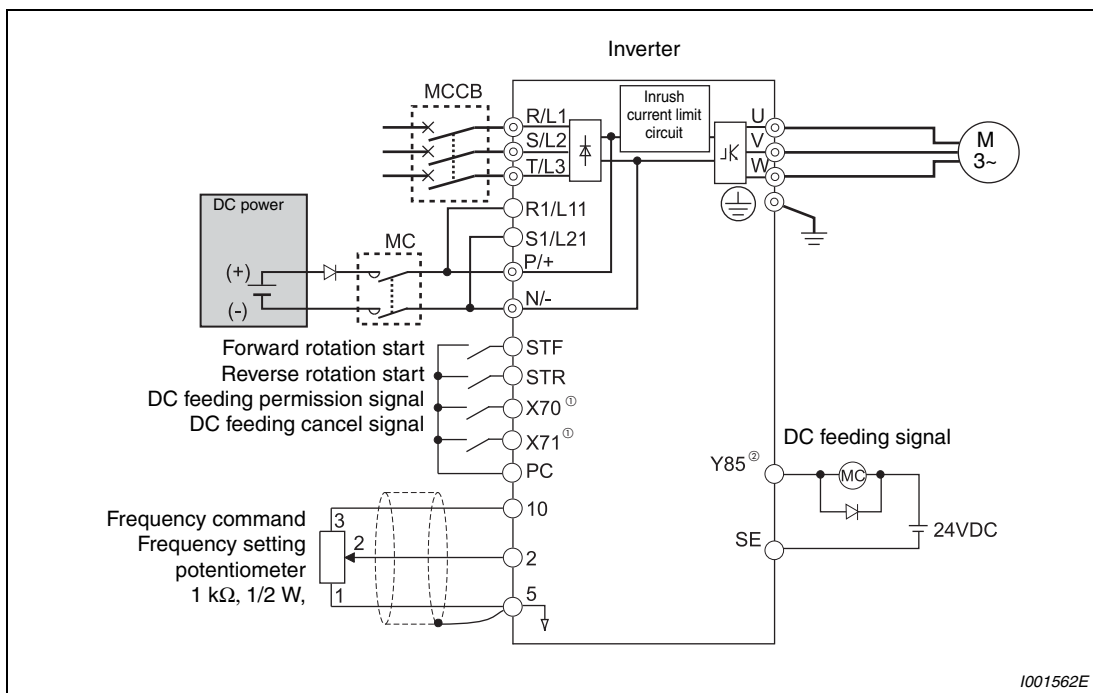

I001562E

**Fig. 6-102:** Connection example for DC feeding mode 2

- ① Assign the function using Pr. 178 to Pr. 189 (input terminal function selection).
- ② Assign the function using Pr. 190 to Pr. 196 (output terminal function selection).

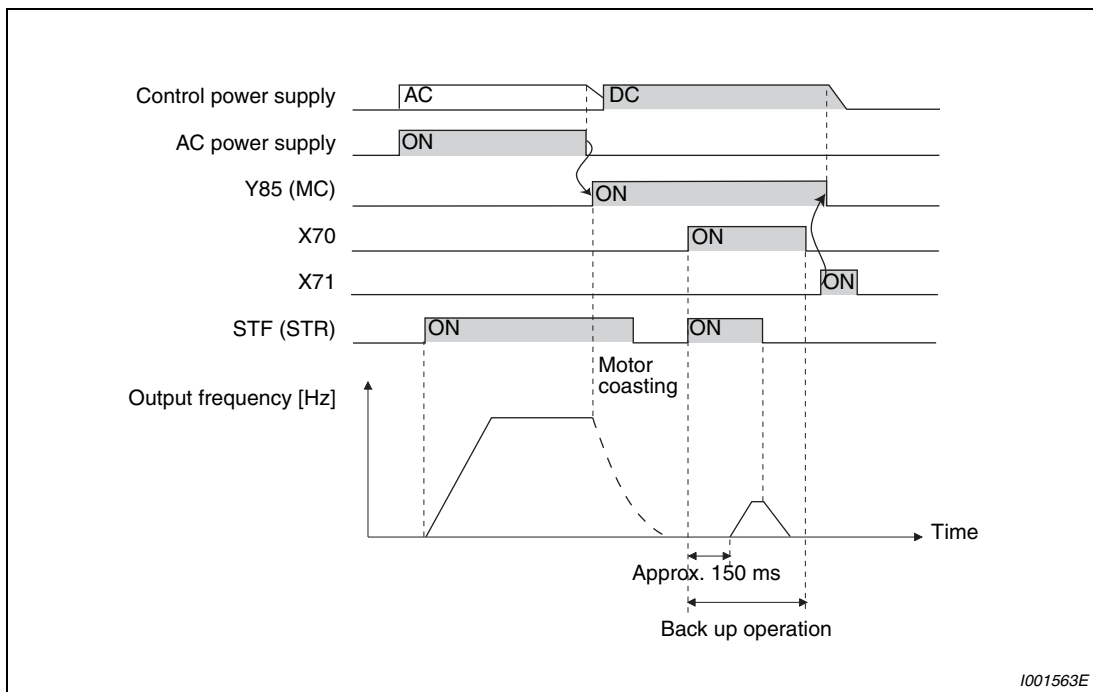

I001563E

**Fig. 6-103:** Operation example 1 at power failure

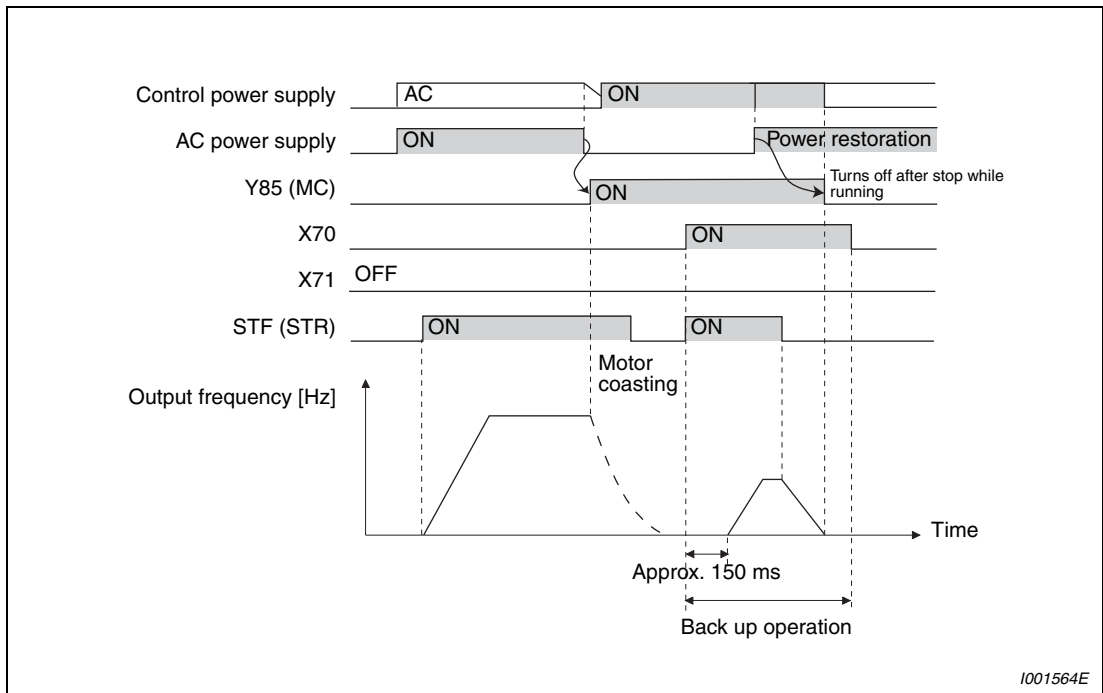

**Fig. 6-104:** Operation example 2 at power failure (when DC power is restored)

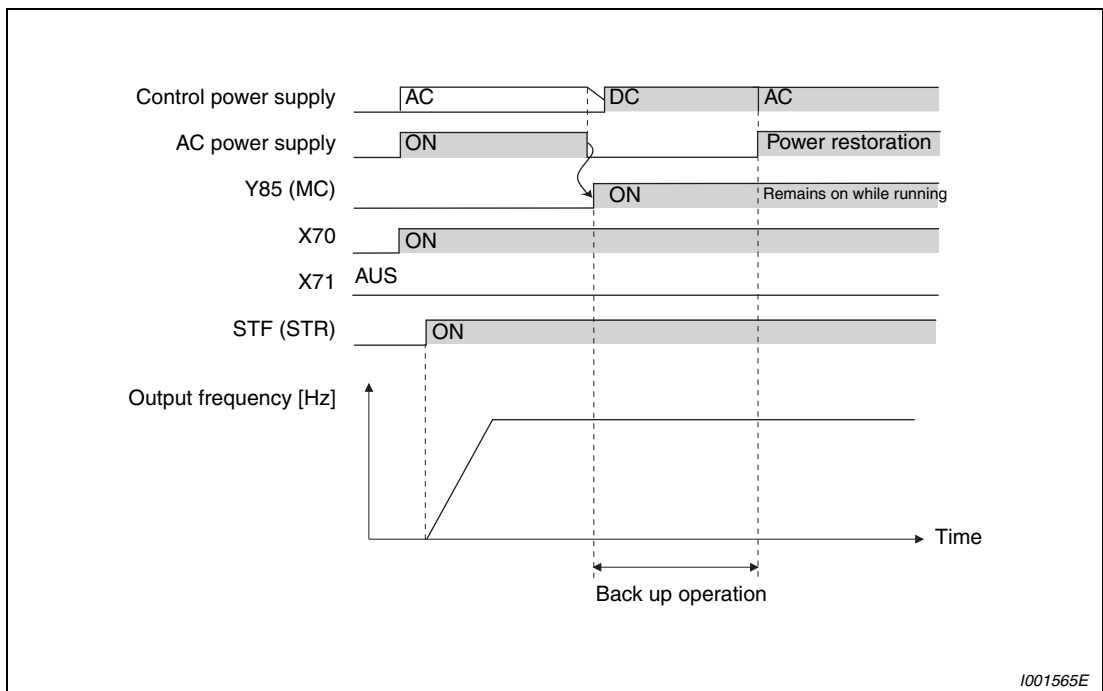

**Fig. 6-105:** Operation example 3 at power failure (when continuous operation is performed)

**Power supply specification at DC feeding**

400V class	Rated input DC voltage	537V DC to 679V DC
	Permissible fluctuation	457V DC to 740V DC



**ACHTUNG:**

**As voltage between P/+, N/- becomes 830V or more temporarily at regeneration, make selection of DC power supply carefully.**

**Regenerative brake duty alarm output and alarm signal (RBP signal)**

- [RB] appears on the operation panel and an alarm signal (RBP) is output when 85% of the regenerative brake duty set in Pr. 70 is reached. If the regenerative brake duty reaches 100% of the Pr. 70 setting, a regenerative overvoltage (E.OV1 to E.OV3) occurs.
- The inverter does not trip even when the alarm (RBP) signal is output.
- For the terminal used for the RBP signal output, assign the function by setting "7 (source logic) or 107 (sink logic)" in any of Pr. 190 to Pr. 196 "Output terminal function selection".

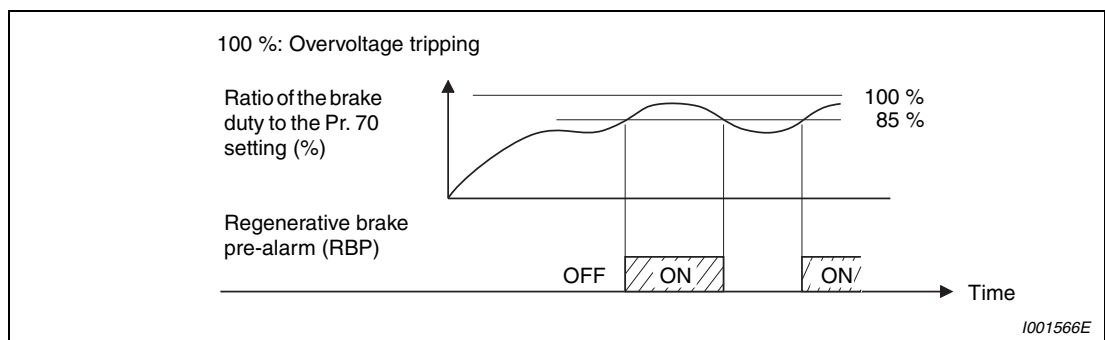

**Fig. 6-106: Regenerative overload**

**NOTES**

- | The MRS signal can also be used instead of the X10 signal.
- | Refer to section 3.8 for the connection of high-duty brake resistor (FR-ABR), brake unit, high power factor converter (FR-HC, MT-HC) and power regeneration common converter (FR-CV).
- | When AC power is connected to terminal R/L1, S/L2, T/L3 during DC feeding with "2, 10, 11, 20, or 21" (DC feeding) set in Pr.30, an option alarm (E.OPT) occurs.
- | When DC feeding operation is performed with "2, 10, 11, 20, or 21" (DC feeding) set in Pr. 30, undervoltage protection (E.UVT) and instantaneous power failure (E.IPF) are not detected.
- | The brake resistor is not connectable to the 00770 or more inverter, the Pr. 70 setting is invalid.
- | When terminal assignment is changed using Pr. 178 to Pr. 189 "Input terminal function selection" and Pr. 190 to Pr. 196 "Output terminal function selection", the other functions may be affected. Make setting after confirming the function of each terminal.



**CAUTION:**

**The value set in Pr. 70 must not exceed the setting of the brake resistor used. Otherwise, the resistor can overheat.**



### 6.13.3 Stop selection (Pr. 250)

Used to select the stopping method (deceleration to a stop or coasting) when the start signal turns off. Used to stop the motor with a mechanical brake, etc. together with switching off of the start signal. You can also select the operations of the start signals (STF/STR). (Refer to section 6.14.4 for start signal selection.)

Pr. No.	Name	Initial Value	Setting Range	Description		Parameters referred to	Refer to Section
				Start Signal (STF/STR)	Stop Operation		
<b>250</b>	Stop selection	9999	0-100s	STF: Forward rotation start STR: Reverse rotation start	The motor is coasted to a stop when the preset time elapses after the start signal is turned off.	7 Acceleration time 8 Deceleration time 13 starting frequency	6.11.1 6.11.1 6.11.2
			1000s-1100s	STF: Start signal STR: Forward/reverse signal	The motor is coasted to a stop (Pr. 250 - 1000)s after the start signal is turned off.		
			9999	STF: Forward rotation start STR: Reverse rotation start	When the start signal is turned off, the motor decelerates to stop.		
			8888	STF: Start signal STR: Forward/reverse signal			

Set Pr. 250 to "9999" (initial value) or "8888". The motor decelerates to a stop when the start signal (STF/STR) turns off.

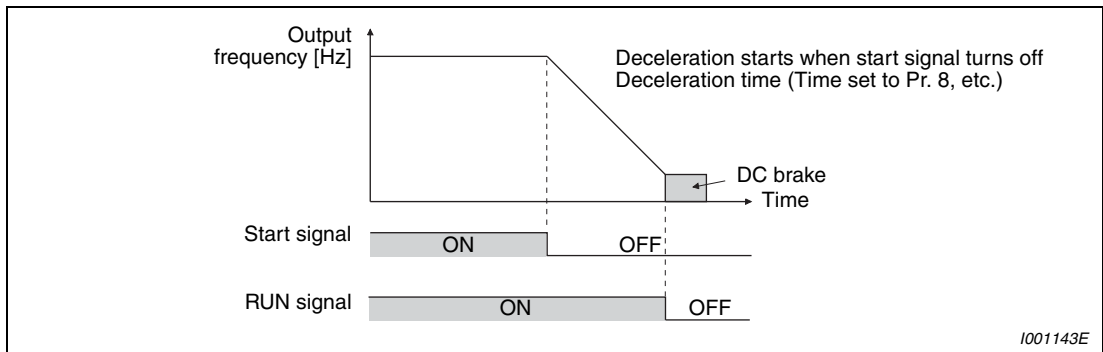

**Fig. 6-107:** Stop operation when parameter 250 = 9999

Use Pr. 250 to set the time from when the start signal turns off until the output is shut off. When any of "1000" to "1100" is set, the output is shut off after (Pr. 250 - 1000)s.

The output is shut off when the time set in Pr. 250 has elapsed after the start signal had turned off. The motor coasts to a stop.

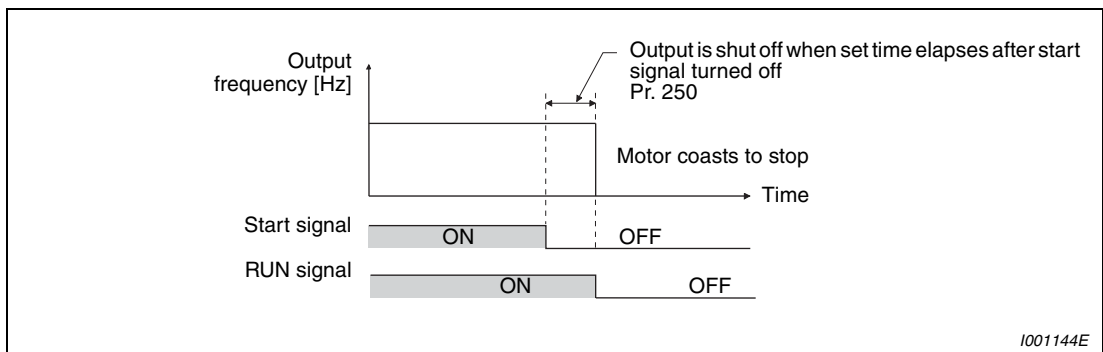

**Fig. 6-108:** Stop operation when parameter 250 ≠ 8888 or 9999

**NOTES**

The RUN signal turns off when the output stops.

Stop selection is invalid when the following functions are activated.

- Position control (Pr. 419 = 0)
- Power failure stop function (Pr. 261)
- PU stop (Pr. 75)
- Deceleration stop because of fault definition (Pr. 875)
- Deceleration stop because of communication error (Pr. 502)
- Offline auto tuning (with motor running)
- Emergency stop by LonWorks communication

When the start signal is turned on again during motor coasting, the motor starts at Pr. 13 "Starting frequency".

### 6.13.4 Stop-on contact control function (Pr. 6, Pr. 48, Pr. 270, Pr. 275, Pr. 276) Magnetic flux Sensorless

To ensure accurate positioning at the upper limit etc. of a lift, stop-on-contact control causes a mechanical brake to be closed while the motor is developing a holding torque to keep the load in contact with a mechanical stopper etc. This function suppresses vibration which is liable to occur when the load is stopped upon contact in vertical motion applications, ensuring steady precise positioning.

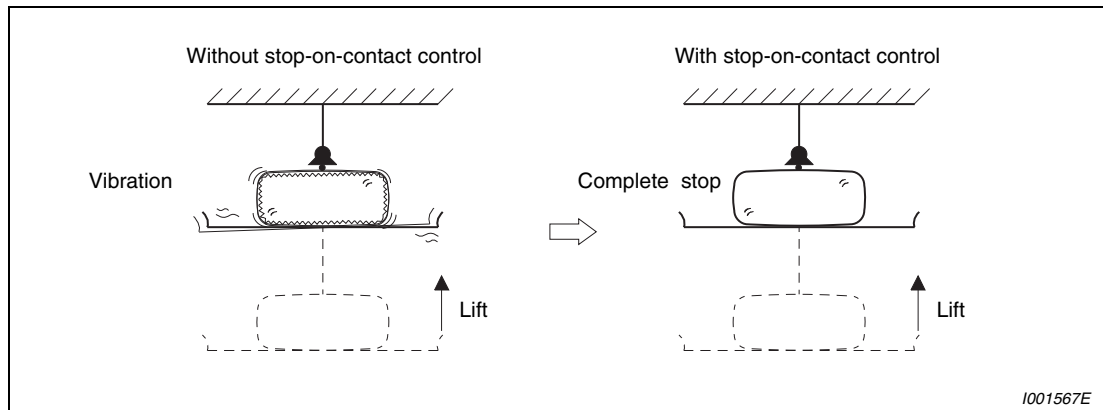

**Fig. 6-109:** Suppressing vibration in vertical motion applications

Pr. No.	Name	Initial Value	Setting Range	Description	Parameters referred to	Refer to Section
<b>6</b>	Multi-speed setting (low speed)	10Hz	0 to 400Hz	Sets the output frequency for stop-on-contact control.	4-6 Multi-speed setting	6.10.1
<b>22</b>	Stall prevention operation level	150% ①	0 to 400%	Set the stall prevention operation level for stop-on-contact control.	15 Jog frequency	6.10.2
<b>48</b>	Second stall prevention operation current	150% ①	0 to 220% ①	The smaller value set in either Pr. 22 or Pr. 48 has a priority.	22 Stall prevention operation level	6.7.4
<b>270</b>	Stop-on contact control selection	0	0	Normal operation	E.OLT ( Stall prevention stop) detection is inactive during stop-on-contact control	48 Second stall prevention operation current
			1	Stop-on-contact control		
			2	Load torque high speed frequency control (Refer to section 6.24.3)		
			3	Stop-on-contact+load torque high speed frequency control (Refer to section 6.24.3)		
			11 ②	Stop-on-contact control		
			13 ②	Stop-on-contact+load torque high speed frequency control (Refer to section 6.24.3)		
<b>275</b>	Stop-on contact excitation current low-speed multiplying factor	9999	0 to 1000%	Set the force (holding torque) for stop-on-contact control. Normally set 130% to 180%. Valid only during advanced magnetic flux vector control.	178-189 Input terminal function selection	6.24.1 6.14.1
			9999	Without compensation		
<b>276</b>	PWM carrier frequency at stop-on contact	9999	01800 or less	0 to 9	Set a PWM carrier frequency for stop-on-contact control. For real sensorless vector control, carrier frequency is always 2Hz when a setting value is 0 to 5 and always 6Hz when a setting value is 6 to 9. (Valid at the frequency of 3Hz or less.)	270 2, 3, 13 (load torque high speed frequency control)
			02160 or more	0 to 4		
			9999	As set in Pr. 72 "PWM frequency selection".		

- ① When Pr. 570 "Multiple rating setting ≠ "2", performing all parameter clear and inverter reset changes the initial value and setting range. (Refer to section 6.7.5).
- ② Pr. 270 can be set to "11" or "13" in frequency inverters of the FR-A700 EC series manufactured in December 2010 or later (refer to section 1.2).

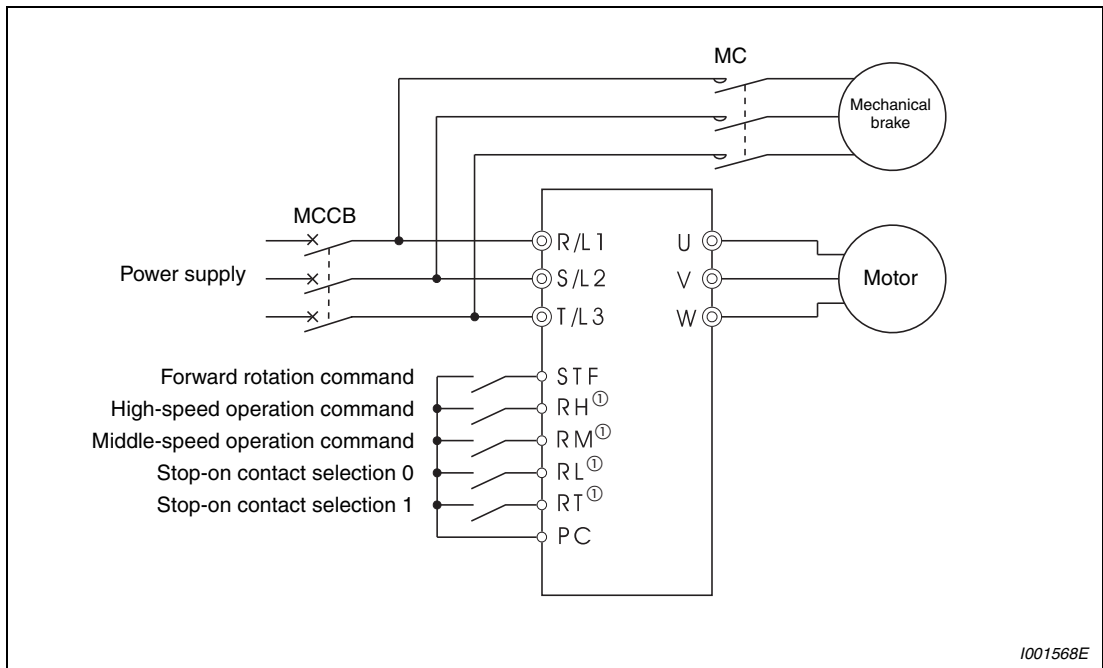

**Fig. 6-110: Connection example**

① The input signal terminal used differs according to the Pr. 180 to Pr. 189 settings.

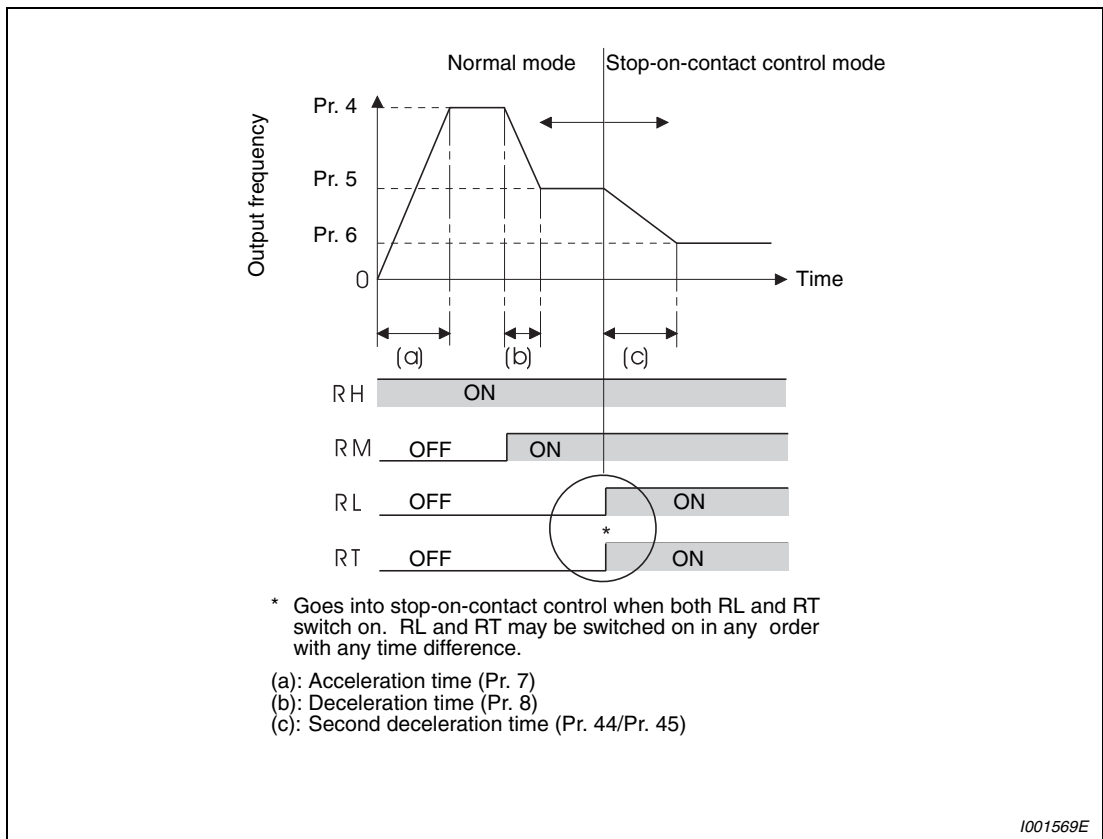

**Fig. 6-111: Switchng to the stop-on contact control mode**

**Set stop-on-contact control**

- Make sure that the inverter is in external operation mode. (Refer to section 6.22.1)
- Select either real sensorless vector control or advanced magnetic flux vector control.
- Set "1", "3", "11" or "13§ in Pr. 270 "Stop-on contact/load torque high-speed frequency control selection".
- Set output frequency during stop-on-contact control in Pr. 6 "Multi-speed setting (low speed)".  
The frequency should be as low as possible (about 2Hz). If it is set to more than 30Hz, the operating frequency will be 30Hz.
- When both the RT and RL signals are switched on, the inverter enters the stop-on-contact mode, in which operation is performed at the frequency set in Pr. 6 independently of the preceding speed.

**NOTES**

By increasing the Pr. 275 setting, the low-speed (stop-on-contact) torque increases, but overcurrent fault (E.OCT) may occur or the machine may oscillate in a stop-on-contact state.

The stop-on-contact function is different from servo-lock function, and if used to stop or hold a load for an extended period, this function can cause the motor to overheat. After a stop, immediately change to a mechanical brake to hold the load.

Under the following operating conditions, the stop-on-contact function is made invalid:

- PU operation (Pr. 79)
- Jog operation (JOG signal)
- PU+external operation (Pr. 79)
- PID control function operation (Pr.128)
- Remote setting function operation (Pr. 59)
- Start time tuning
- Orientation control function operation (FR-A7AP option)

When performing stop-on-contact control during encoder feedback control, encoder feedback control is made invalid due to a mode shift to the stop-on-contact control mode.

**Function switching of stop-on-contact control selection**

Main Functions	Normal Operation (either RL or RT is off or both are off)		With stop-on-contact Control (both RL and RT are on)	
	Real sensorless vector control	Advanced magnetic flux vector control	Real sensorless vector control	Advanced magnetic flux vector control
Output frequency	Multi-speed 0 to 5V, 0 to 10V, 4 to 20mA etc.		Pr. 6	
Stall prevention operation level	—	Pr. 22	—	The smaller value set in either Pr. 22 or Pr. 48 ①
Torque limit level	—		Pr. 22	—
Excitation current low speed scaling factor	—		—	The current is compensated for by Pr. 275 (0 to 1000%) settings before RL and RT are switched on.
Carrier frequency	Pr. 72		Pr. 276 setting when output frequency is 3Hz or less (Pr. 72 when Pr. 276 = "9999")	
Fast-response current limit	—	Valid	—	Invalid

**Tab. 6-70:** Function switching of stop-on-contact control selection

① When RL and RT are on, Pr. 49 "Second stall prevention operation frequency" is invalid.

**Set frequency when stop-on-contact control (Pr. 270 = 1 or 3) is selected**

The following table lists the frequencies set when the input terminals (RH, RM, RL, RT, JOG) are selected together. Bold frame indicates stop-on-contact control is valid.

Stop-on-contact control is invalid when remote setting function is selected (Pr. 59 = 1 to 3).

Input Signal					Stop-on Contact	Set Frequency
RH	RM	RL	RT	JOG		
ON						Pr. 4 "Multi-speed setting (high speed)"
	ON					Pr. 5 "Multi-speed setting (middle speed)"
		ON				Pr. 6 "Multi-speed setting (low speed)"
			ON			By 0 to 5V (0 to 10V), 4 to 20mA input
				ON		Pr. 15 "Jog frequency"
ON	ON					Pr. 26 "Multi-speed setting (speed 6)"
ON		ON				Pr. 25 "Multi-speed setting (speed 5)"
ON			ON			Pr. 4 "Multi-speed setting (high speed)"
ON				ON		Pr. 15 "Jog frequency"
	ON	ON				Pr. 24 "Multi-speed setting (speed 4)"
	ON		ON			Pr. 5 "Multi-speed setting (middle speed)"
	ON			ON		Pr. 15 "Jog frequency"
		ON	ON		Valid	Pr. 6 "Multi-speed setting (low speed)"
		ON		ON		Pr. 15 "Jog frequency"
			ON	ON		Pr. 15 "Jog frequency"
		ON	ON	ON		Pr. 15 "Jog frequency"
	ON		ON	ON		Pr. 15 "Jog frequency"
	ON	ON		ON		Pr. 15 "Jog frequency"
	ON	ON	ON		Valid	Pr. 6 "Multi-speed setting (low speed)"
ON			ON	ON		Pr. 15 "Jog frequency"
ON		ON		ON		Pr. 15 "Jog frequency"
ON		ON	ON		Valid	Pr. 6 "Multi-speed setting (low speed)"
ON	ON			ON		Pr. 15 "Jog frequency"
ON	ON		ON			Pr. 26 "Multi-speed setting (speed 6)"
ON	ON	ON				Pr. 27 "Multi-speed setting (speed 7)"
	ON	ON	ON	ON		Pr. 15 "Jog frequency"
ON		ON	ON	ON		Pr. 15 "Jog frequency"
ON	ON		ON	ON		Pr. 15 "Jog frequency"
ON	ON	ON		ON		Pr. 15 "Jog frequency"
ON	ON	ON	ON		Valid	Pr. 6 "Multi-speed setting (low speed)"
ON	ON	ON	ON	ON		Pr. 15 "Jog frequency"
						By 0 to 5V (0 to 10V), 4 to 20mA input

**Tab. 6-71:** Frequency and combined input signals

**NOTE** | Changing the terminal function using any of Pr. 178 to Pr. 189 may affect the other functions. Make setting after confirming the function of each terminal.

### 6.13.5 Brake sequence function

(Pr. 278 to Pr. 285, Pr. 292) Magnetic flux Sensorless Vector

This function is used to output from the inverter the mechanical brake operation timing signal in vertical lift and other applications. This function prevents the load from dropping with gravity at a start due to the operation timing error of the mechanical brake or an overcurrent alarm from occurring at a stop, ensuring secure operation.

Pr. No.	Name	Initial Value	Setting Range	Description
278	Brake opening frequency	3Hz	0-30Hz	Set to the rated slip frequency of the motor + about 1.0Hz. This parameter may be set only if Pr. 278 ≤ Pr. 282.
279	Brake opening current	130%	0-220% <sup>②</sup>	Generally, set this parameter to about 50 to 90%. If the setting is too low, the load is liable to drop due to gravity at start. Suppose that the rated inverter current is 100%.
280	Brake opening current detection time	0.3s	0-2s	Generally, set this parameter to about 0.1 to 0.3s.
281	Brake operation time at start	0.3s	0-5s	When Pr. 292 = 7, set the mechanical delay time until the brake is loosened. Set the mechanical delay time until the brake is loosened + about 0.1 to 0.2s when Pr. 292 = 8.
282	Brake operation frequency	6Hz	0-30Hz	Set the frequency to activate the mechanical brake by turning off the brake opening request signal (BOF). Generally, set this parameter to the Pr. 278 setting + 3 to 4Hz. This parameter may be set only if Pr. 278 ≤ Pr. 282.
283	Brake operation time at stop	0.3s	0-5s	Set the mechanical delay time until the brake is closed + 0.1s when Pr. 292 = 7. Sets the mechanical delay time until the brake is closed + 0.2 to 0.3s when Pr. 292 = 8.
284	Deceleration detection function selection	0	0	Deceleration is not detected.
			1	If deceleration is not normal during deceleration operation, the inverter alarm is provided.
285	Overspeed detection frequency <sup>①</sup>	9999	0-30Hz	If (detected frequency) - (output frequency) If (detected frequency) - (output frequency) ≥ Pr. 285 during encoder feedback control, the inverter alarm (E.MB1) is provided.
			9999	Overspeed is not detected
292	Automatic acceleration/ deceleration	9999	0	Normal operation mode
			1/11	Shortest acceleration/deceleration mode (Refer to page 6-209)
			3	Optimum acceleration/deceleration mode (Refer to page 6-210)
			5/6	Elevator mode (Refer to section 6.9.3)
			7	Brake sequence mode 1
			8	Brake sequence mode 2

Parameters referred to		Refer to Section
80	Motor capacity	6.2.2
81	Number of motor poles	6.2.2
178-186	Input terminal function selection	6.14.1
190-196	Output terminal function selection	6.14.5

- ① When exercising vector control with the FR-A7AP, this parameter changes to excessive speed deviation detection frequency (For details, refer to section 6.3.6)
- ② When Pr. 570 Multiple rating setting ≠ "2", performing all parameter clear and inverter reset changes the setting range. (Refer to section 6.7.5)



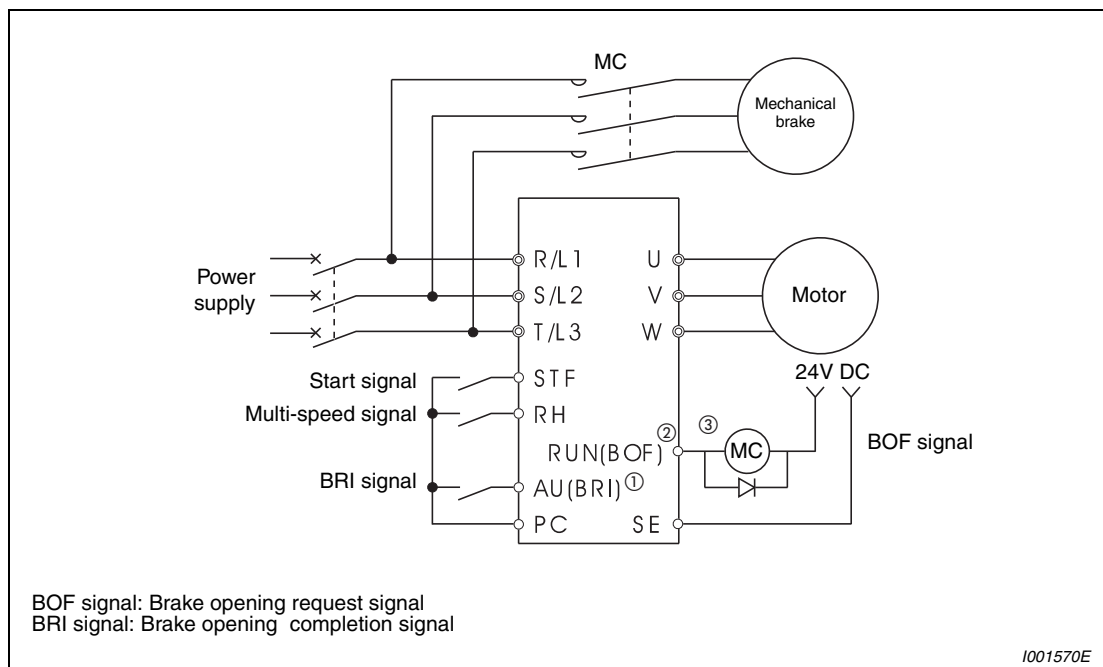

**Fig. 6-112:** Connection example with mechanical brake (Pr. 184 = 15, Pr. 190 = 20)

- ① The input signal terminal used differs according to the Pr. 178 to Pr. 189 settings.
- ② The output signal terminal used differs according to the Pr. 190 to Pr. 196 settings.
- ③ The current should be within the permissible current of the transistor in the inverter. (24V/ 0.1A DC)

#### NOTES

When brake sequence mode is selected, automatic restart after instantaneous power failure is invalid.

When using this function, set the acceleration time to 1s or longer.

Changing the terminal function using any of Pr. 178 to Pr. 186 and Pr. 190 to Pr. 196 may affect the other functions. Make setting after confirming the function of each terminal.

**Set the brake sequence mode**

- Select either real sensorless vector control, vector control (speed control) or advanced magnetic flux vector control. The brake sequence function is valid only when the external operation mode, external/PU combined operation mode 1 or network operation mode is selected
- Set "7 or 8" (brake sequence mode) in Pr. 292. To ensure more complete sequence control, it is recommended to set "7" (brake opening completion signal input) in Pr. 292.
- Set "15" in any of Pr. 178 to Pr. 189 "Input terminal function selection" and assign the brake opening completion signal (BRI) to the input terminal.
- Set "20 (source logic)" or "120 (sink logic)" in any of Pr. 190 to Pr. 196 "Output terminal function selection" and assign the brake opening request signal (BOF) to the output terminal.



**CAUTION:**

*In lift applications where an inadvertent lifting of the holding brake can lead to personal injury or property damage, the BOF signal may be used for safety reasons only in source logic, that is, setting "20".*

**With brake opening completion signal input (Pr. 292 = 7)**

- When the start signal is input to the inverter, the inverter starts running. When the internal speed command reaches the value set in Pr. 278 and the output current is not less than the value set in Pr. 279, the inverter outputs the brake opening request signal (BOF) after the time set in Pr. 280 has elapsed.

When the time set in Pr. 281 elapses after the brake opening completion signal (BRI) was activated, the inverter increases the output frequency to the set speed.

- When the speed has decreased to the frequency set in Pr. 282 during deceleration, the BOF signal is turned off. When the time set in Pr. 283 elapses after the electromagnetic brake operation was completed and the BRI signal was turned off, the inverter output is switched off.

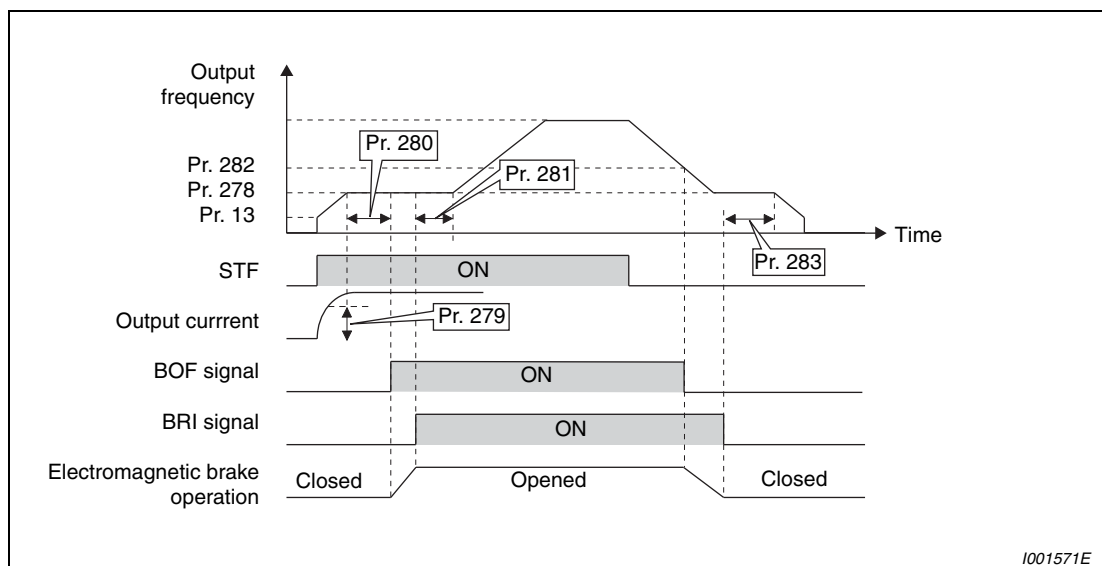

**Fig. 6-113: Operation when parameter 292 = 7**

**With brake opening completion signal input (Pr. 292 = 8)**

- When the start signal is input to the inverter, the inverter starts running. When the internal speed command reaches the value set in Pr. 278 and the output current is not less than the value set in Pr. 279, the inverter outputs the brake opening request signal (BOF) after the time set in Pr. 280 has elapsed. When the time set in Pr. 281 elapses after the BOF signal is output, the inverter increases the output frequency to the set speed.
- When the speed has decreased to the frequency set in Pr. 282 during deceleration, the brake opening request signal (BOF) is turned off. When the time set in Pr. 283 has elapsed after the BOF signal is turned off, the inverter output is switched off.

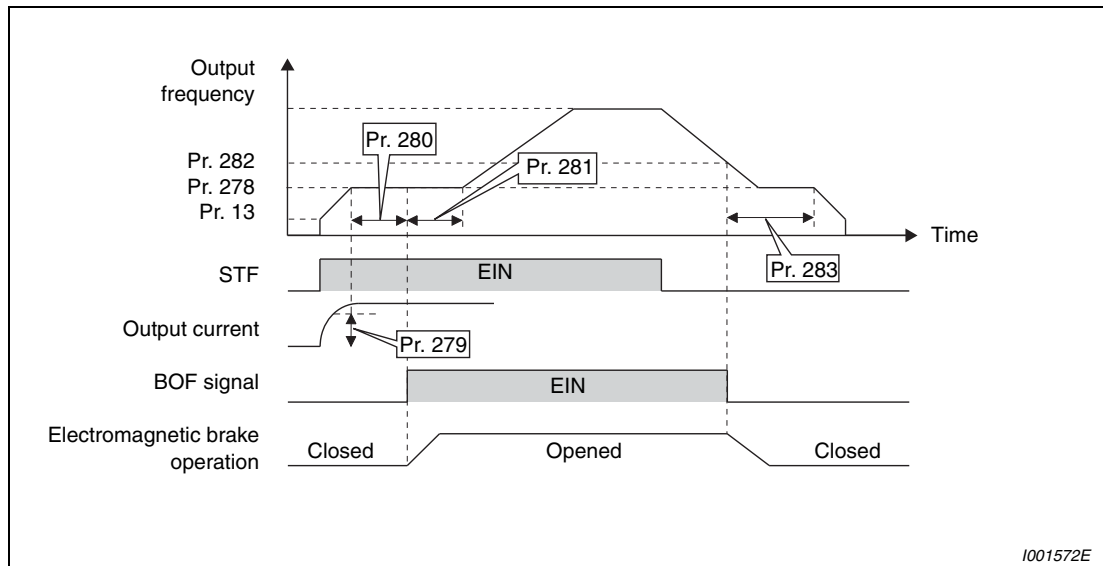

**Fig. 6-114:** Operation when parameter 292 = 8

**NOTE**

Even if automatic acceleration/deceleration has been selected, inputting the jog signal (jog operation), RT signal (second function selection) or X9 signal (third function selection) during an inverter stop will switch to the normal operation and give priority to jog operation or second and third function selection. Note that JOG and RT signal input is invalid even if JOG signal and RT signal are input during automatic acceleration/deceleration operation.

### Protective functions

If any of the following errors occurs in the brake sequence mode, the inverter results in a fault, trips, and turns off the brake opening request signal (BOF).

Fault Display	Description
E.MB1	(Detection frequency) - (output frequency) > Pr. 285 during encoder feedback control When Pr. 285 Overspeed detection frequency = 9999, overspeed is not detected.
E.MB2	Deceleration is not normal during deceleration operation from the set frequency to the frequency set in Pr. 282. (when Pr. 284 =1) (except stall prevention operation).
E.MB3	Brake opening request signal (BOF) turned on though the motor is at a stop. (gravity drop prevention function).
E.MB4	Although more than 2s have elapsed after the start command (forward or reverse rotation) is input, the brake opening request signal (BOF) does not turn on.
E.MB5	Although more than 2s have elapsed after the brake opening request signal (BOF) turned on, the brake opening completion signal (BRI) does not turn on.
E.MB6	Though the inverter had turned on the brake opening request signal (BOF), the brake opening completion signal (BRI) turned off midway.
E.MB7	Although more than 2s have elapsed after the brake opening request signal (BOF) turned off at a stop, the brake opening completion signal (BRI) does not turn off.

**Tab. 6-72:** Protective functions

#### NOTES

Overspeed detection (Pr. 285) is valid under encoder feedback control (used with the FR-A7AP option) even if a value other than "7 or 8" is set in Pr. 292.

A too large setting of Pr. 278 "Brake opening frequency" activates stall prevention operation and may cause E.MB4.

**6.13.6 Orientation control (Pr. 350 bis Pr. 366, Pr. 369, Pr. 393, Pr. 396 to Pr. 399)** V/F Magnetic flux Vector

This function is used with a position detector (encoder) installed to the spindle of a machine tool, etc. to allow a rotation shaft to be stopped at the specified position (oriented). Option FR-A7AP is necessary. Pr. 350 Stop position command selection is initially set to "9999", orientation control function is invalid.

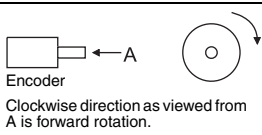
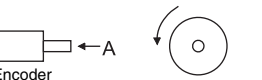
Pr. No.	Name	Initial Value	Setting Range	Description	Parameters referred to	Refer to Section
<b>350</b>	Stop position command selection	9999	0	Internal stop position command (Pr. 356)	—	
			1	External stop position command (FR-A7AX 16-bit data)		
			9999	Orientation control invalid		
<b>351</b>	Orientation speed	2 Hz	0 to 30Hz	Decrease the motor speed to the set value when the orientation command (X22) is given.		
<b>352</b>	Creep speed	0.5 Hz	0 to 10Hz	After the speed reaches the orientation speed, the speed decreases to the creep speed set in Pr. 352 as soon as the current position pulse reaches the creep switchoverposition set in Pr. 353.		
<b>353</b>	Creep switchover position	511	0 to 16383 ①			
<b>354</b>	Position loop switchover position	96	0 to 8191	As soon as the current position pulse reaches the set position loop switchover position, control is changed to position loop.		
<b>355</b>	DC injection brake start position	5	0 to 255	After changed to position loop, DC injection brake is applied and the motor stops as soon as the current position pulse reaches the set DC injection brake start position.		
<b>356</b>	Internal stop position command	0	0 to 16383 ①	When "0" is set in Pr. 350, the internal position command is activated and the setting value of Pr. 356 becomes a stop position.		
<b>357</b>	Orientation in-position zone	5	0 to 255	Set the in-position zone at a stop of the orientation.		
<b>358</b>	Servo torque selection	1	0 to 13	Functions at orientation completion can be selected.		
<b>359</b>	Encoder rotation direction	1	0	 <p>Encoder Clockwise direction as viewed from A is forward rotation.</p>		
			1	 <p>Encoder Counter clockwise direction as viewed from A is forward rotation.</p>		

Pr. No.	Name	Initial Value	Setting Range	Description
360	16 bit data selection	0	0	Speed command
			1	16 bit data is used as external position command as is.
			2 to 127	Set the stop position dividing up to 128 stop positions at regular intervals.
360	16 bit data selection	0		When 1 is set in Pr. 350 and the FR-A7AX is mounted, set a stop position using 16-bit data. Stop position command is input as binary regardless of the Pr. 304 setting. ②
361	Position shift	0	0 to 16383 ①	Shift the origin using a compensation value without changing the origin of the encoder. The stop position is a position obtained by adding the setting value of Pr. 361 to the position command.
362	Orientation position loop gain	1	0.1 to 100	When servo torque function is selected using Pr. 358, output frequency for generating servo torque increases to the creep speed of Pr. 352 gradually according to the slope set in Pr. 362. Although the operation becomes faster when the value is increased, a machine may hunt, etc.
363	Completion signal output delay time	0.5s	0 to 5.0s	The orientation complete signal is output delaying the set time after in-position zone is entered. Also, the signal turns off delaying the set time after in-position zone is out.
364	Encoder stop check time	0.5s	0 to 5.0s	Orientation fault signal (ORM) is output when the encoder remains stopped for the set time without orientation completion in the state where no orientation complete signal (ORA) is output. ORM signal is output when orientation is not completed again in the set time in the state where ORA signal is output.
365	Orientation limit	9999	0 to 60.0s	Measure the time taken after passing the creep switchover position and output the orientation fault signal (ORM) if orientation is not completed within the set time.
			9999	Set to 120s.
366	Recheck time	9999	0 to 5.0s	Turning off the start signal with orientation command (X22) on after stopping the motor by orientation control, the present position is checked again after the set time elapses and the orientation complete signal (ORA) or orientation fault signal (ORM) is output.
			9999	Not checked.

Parameters referred to	Refer to Section
—	

Pr. No.	Name	Initial Value	Setting Range	Description	Parameters referred to	Refer to Section
<b>369</b>	Number of encoder pulses	1024	0 to 4096	Set the number of pulses of the encoder (before multiplied by four).	—	
<b>393</b>	Orientation selection	0	0	Orientation is executed from the current rotation direction.		
			1	Orientation is executed from the forward rotation direction.		
			2	Orientation is executed from the reverse rotation direction.		
<b>396</b>	Orientation speed gain (P term)	60	0 to 1000	Response level during position control loop (servo rigidity) at orientation stop can be adjusted.		
<b>397</b>	Orientation speed integral time	0.333	0 to 20.0s			
<b>398</b>	Orientation speed gain (D term)	1	0 to 100.0	Lag/advance compensation gain can be adjusted.		
<b>399</b>	Orientation deceleration ratio	20	0 to 1000	Make adjustment when the motor runs back at orientation stop or the orientation time is long.		

The above parameters can be set when the FR-A7AP (option) is mounted.

- ① When the operation panel (FR-DU07) is used, the maximum setting is 9999. When a parameter unit is used, up to the maximum value within the setting range can be set.
- ② For a detailed description of the parameters please refer to the FR-A7AX (option) manual.

Connection example

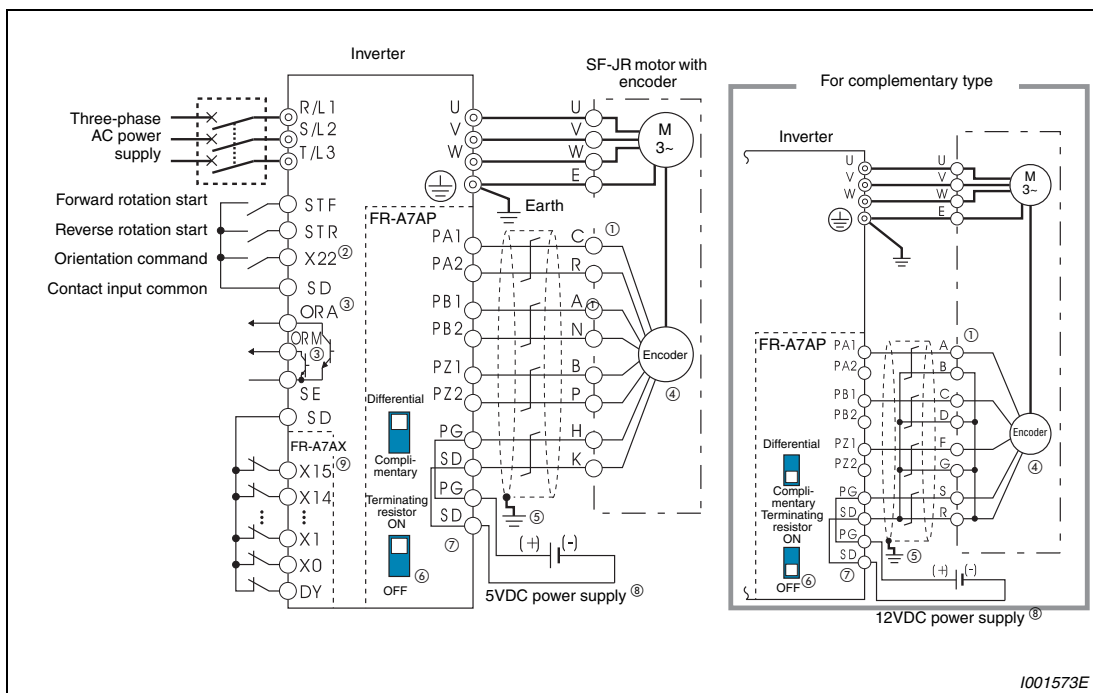

Fig. 6-115: Connection example

- ① The pin number differs according to the encoder used.
- ② Use Pr. 178 to Pr. 189 (input terminal function selection) to assign the function to any of terminal. (Refer to section 6.14.1).
- ③ Use Pr. 190 to Pr. 196 (output terminal function selection) to assign the function to any of terminal. (Refer to section 6.14.5).
- ④ Connect the encoder so that there is no looseness between the motor and motor shaft. Speed ratio should be 1:1.
- ⑤ Earth (Ground) the shielded cable of the encoder cable to the enclosure with a P clip, etc. (Refer to page 3-41).
- ⑥ For the differential line driver, set the terminating resistor selection switch to on position (initial status) to use. (Refer to page 3-35.) Note that the terminating resistor switch should be set to off position when sharing the same encoder with other unit (NC, etc) or a terminating resistor is connected to other unit.  
For the complementary, set the switch to off position.
- ⑦ For terminal compatibility of the FR-JCBL and FR-A7AP, refer to page 3-37.
- ⑧ A separate power supply of 5V/12V/15V/24V is necessary according to the encoder power specification.  
When performing encoder feedback control and vector control together, an encoder and power supply can be shared.
- ⑨ SWhen a stop position command is input from outside, a plug-in option FR-A7AX is necessary. Refer to page 6-274 for external stop position command.)

NOTE

In the above diagram a connection example for sink logic is shown.



### Setting

If the orientation command signal (X22) is turned on during operation after the various parameters have been set, the speed will decelerate to the "orientation switchover speed". After the "orientation stop distance" is calculated, the speed will further decelerate, and the "orientation state" (servo lock) will be entered. The "orientation complete signal" (ORA) will be output when the "orientation complete width" is entered.

### Setting I/O signals

Terminal	Terminal Name	Description
X22 ①	Orientation command input	Used to enter an orientation signal for orientation. For the terminal used for X22 signal input, set "22" in any of Pr. 178 to Pr. 189 to assign the function.
SD	Contact input common	Common terminal for the orientation signal.
ORA ②	Orientation complete signal output	Switched low if the orientation has stopped within the in-position zone while the start and orientation signals are input. For the terminal used for the ORA signal output, assign the function by setting "27 (source logic) or 127 (sink logic)" in any of Pr. 190 to Pr. 196.
ORM ②	Orientation fault signal output	Switched low if the orientation has not stopped within the in-position zone while the start and orientation signals are input. For the terminal used for the ORM signal output, assign the function by setting "28 (source logic) or 128 (sink logic)" in any of Pr. 190 to Pr. 196.
SE	Open collector output common	Common terminal for the ORA and ORM open collector output terminals.

**Tab. 6-73:** Setting I/O signals

- ① For X22 signals, assign functions to any of terminal using Pr. 178 to Pr. 189 (output terminal function selection). (Refer to section 6.14.1).
- ② For ORA and ORM signals, assign functions to any of terminal using Pr. 190 to Pr. 196 (output terminal function selection). (Refer to section 6.14.5).

**Selecting stop position command (Pr. 350)**

Select either the internal stop position command (Pr. 356) or the external stop position command (16-bit data using the FR-A7AX).

Pr. 350	Stop Position Command Source
0	Internal stop position command (Pr. 356: 0 to 16383)
1	External stop position command (FR-A7AX) 16-bit data
9999 (Initial value)	Orientation control invalid

**Tab. 6-74: Settings for parameter 350**

**Internal stop position command (Pr. 350 = 0)**

The value set in Pr. 356 is the stop position. When the number of encoder pulses is 1024p/r, one revolution of the encoder is divided into 4096 positions, i.e.  $360^\circ/4096$  pulses = 0.0879°/pulses per address, as shown on the right. The stop positions (addresses) are indicated in parentheses.

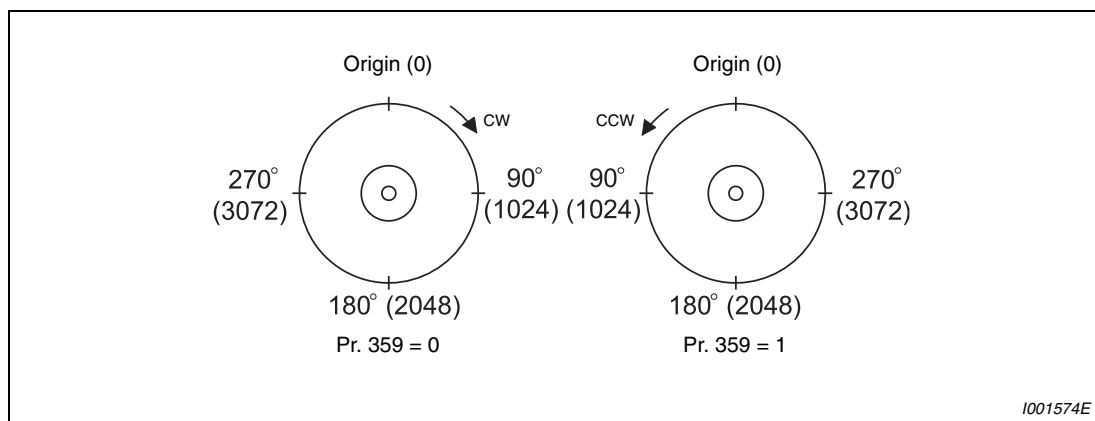

**Fig. 6-116: Encoder addresses**

**External stop position command (Pr. 350 = 1)**

Mount the option FR-A7AX and set a stop position using 16-bit data (binary input). The value set in Pr. 360 "16 bit data selection" should be the number of stop positions less 1.

Pr. 360	Description
0	External position command is made invalid (speed command or torque command with the FR-A7AX)
1	Position command direct input The 16-bit digital signal from the FR-A7AX is directly serves as stop position command. Example When the Pr. 369 Number of encoder pulses setting is 1024, stop position command from 0 to 4095 can be directly input using the FR-A7AX and input digital signal of 2048 (H800) to stop the motor at 180° position. The command more than 4096 is considered as 4095.
2 to 127	Set the stop position command dividing up to 128 stop positions at regular intervals. If the external stop command entered is greater than the setting, the stop positions are the same as those in the maximum external stop command value. Example When the number of stop positions is 90 (divided at intervals of 4°), $90 - 1 = 89$ . Hence, set "89".

**Tab. 6-75: Settings for parameter 360**

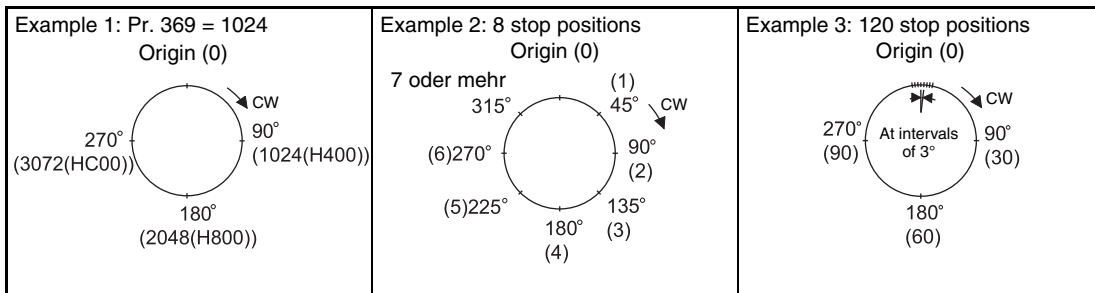

**NOTES**

- Values in parentheses indicate binary data entered from the terminals. Even if the position pulse monitor (Pr. 52 DU/PU main display data selection = 19) is selected, the data monitored is not the number of stop positions but is 0 to 65535 pulses.
- FR-A7AX parameters (Pr. 300 to Pr. 305) are invalid. (Valid when Pr. 360 = "0")
- Terminal DY (data read timing input signal) is made invalid during vector control. (The position data is downloaded at the start of orientation.)
- Internal stop position command is given even if "1" (external stop position command) is set in Pr. 350 when an option card (FR-A7AX) is not mounted or Pr. 360 = "0".

Relationship between stop position command and 16-bit data.

Pr. 350	Pr. 360	Operation		
		Stop position command	16 bit data (FR-A7AX)	Speed command
0: internal	0: Speed command	Internal (Pr. 356)	Speed command	16 bit data
	1, 2 to 127: position command	Internal (Pr. 356)	—	External command (or PU)
1: external	0: Speed command	Internal (Pr. 356)	Speed command	16 bit data
	1, 2 to 127: position command	External (Internal when the FR-A7AX is not mounted (Pr. 356))	Position command	External command (or PU)

**Tab. 6-76:** Relation between parameters 350 and 360

**Parameter 361:** Position shift

The stop position is a position obtained by adding the setting value of Pr. 361 to the position command.

The position shift functions shift the origin using a compensation value without changing the origin of the position detector (encoder).

**NOTE**

When orientation control is made valid using Pr. 350 "Stop position command selection" with the FR-A7AP mounted, the rotation direction of encoder is displayed on the rotation direction display of the PU (FR-DU07/FR-PU04/FR-PU07). Set the parameter so that turning on the STF signal displays FWD or turning on the STR signal displays REV.

**Monitor display change**

Monitor	Description
Position pulse monitor	When "19" is set in Pr. 52 , position pulse monitor is displayed instead of output voltage monitor of the PU. (Displayed only when the FR-A7AP is mounted.)
Orientation status ①	When "22" is set in Pr. 52 , orientation status is displayed instead of output voltage monitor of the PU. (Displayed only when the FR-A7AP is mounted.) 0: Other than orientation operation or orientation speed is not reached 1: Orientation speed is reached 2: Creep speed is reached 3: Position loop is reached 4: Orientation complete 5: Orientatino fault (pulse stop) 6: Orientatino fault (orientation limit) 7: Orientation fault (recheck) 8: Continuous multi-point orientation

**Tab. 6-77: Monitor display change**

① Invalid during vector control. ("0" is always displayed )

**Orientation in-position zone (Pr. 357, Initial value: 5)**

The positioning width for orientation stop can be set. The initial setting of Pr. 357 is "5". To change the Δθ value, finely adjust with ±10 increments, and make fine adjustment.

If the position detection value from the encoder enters ±Δθ during orientation stop, the orientation complete signal (ORA) will be output.

$$\Delta\theta \square \frac{360^\circ}{Pr. 369 \times 4} \times Pr. 357$$

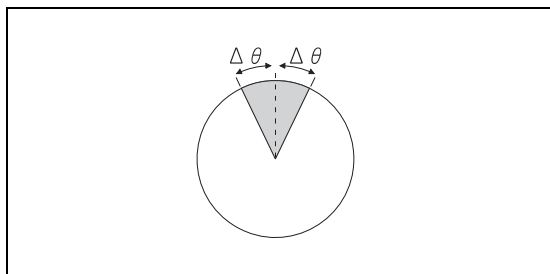

**Fig. 6-117:**  
In-position zone

I001578E

**Orientation operation (under V/f control, advanced magnetic flux vector control)**

## ● Orientation during running

- ① When the orientation command (X22) is input, the motor speed decreases to the orientation speed set in Pr. 351 "Orientation speed". (Pr. 351 initial value: 2Hz)
- ② After the speed reaches the orientation speed, the speed decreases to the creep speed set in Pr. 352 "Creep speed" as soon as the current position pulse reaches the creep switchover position set in Pr. 353 "Creep switchover position" (Pr. 352 initial value: 0.5Hz, Pr. 353 initial value: 511)
- ③ Moreover, as soon as the current position pulse reaches the set position loop switchover position in Pr. 354 "Position loop switchover position", control is changed to position loop. (Pr. 354 initial value: 96)
- ④ After switching to position loop, the inverter decelerates and stops with DC injection brake as soon as the current position pulse has reached the DC injection brake start position set in Pr. 355 "DC injection brake start position". (Pr. 355 initial value: 5)
- ⑤ When the position pulse has stopped within the in-position zone set in Pr. 357 "Orientation in-position zone", the orientation completion signal (ORA) is output after the completion signal output delay time set in Pr. 363 "Completion signal output delay time" has elapsed. If the motor does not stop within the in-position zone due to external force, etc., the orientation completion signal is turned off after the time set in Pr. 363 "Completion signal output delay time" has elapsed. (Pr. 357 initial value: 5)
- ⑥ If the orientation is not completed continuously for the time set in Pr. 365 "Orientation limit" after passing the creep switchover position, the orientation fault signal (ORM) is output.
- ⑦ When the motor stops before the position pulse reaching the in-position zone due to external force after orientation start and orientation completion signal (ORA) is not output, orientation fault signal (ORM) is output after the time set in encoder stop check time set in Pr. 364 Encoder stop check time has elapsed. Moreover, the orientation complete signal (ORA) is turned off after the time set in Pr. 363 "Completion signal output delay time" has elapsed if the position pulse is outside the in-position zone due to external force, etc. after outputting the orientation complete signal (ORA), and the orientation fault signal (ORM) is output if the orientation has not completed within the time set in Pr. 364 "Encoder stop check time".
- ⑧ When the start signal (STF or STR) is turned off with the orientation command on after outputting the orientation completion signal (ORA) and orientation fault signal (ORM), the orientation complete signal (ORM) or orientation fault signal (ORM) is output again after recheck time set in Pr. 366 "Recheck time" has elapsed.
- ⑨ The orientation completion signal (ORA) and orientation fault signal (ORM) are not output when the orientation command is off.

**NOTES**

When the orientation command is off with the start signal on, the speed accelerates to the command speed.

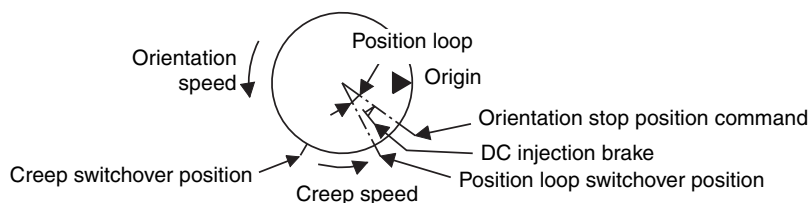

If the motor shaft hants, set a larger value in Pr. 354 "Position loop switchover position" or a smaller value in Pr. 352 "Creep speed" to prevent it.

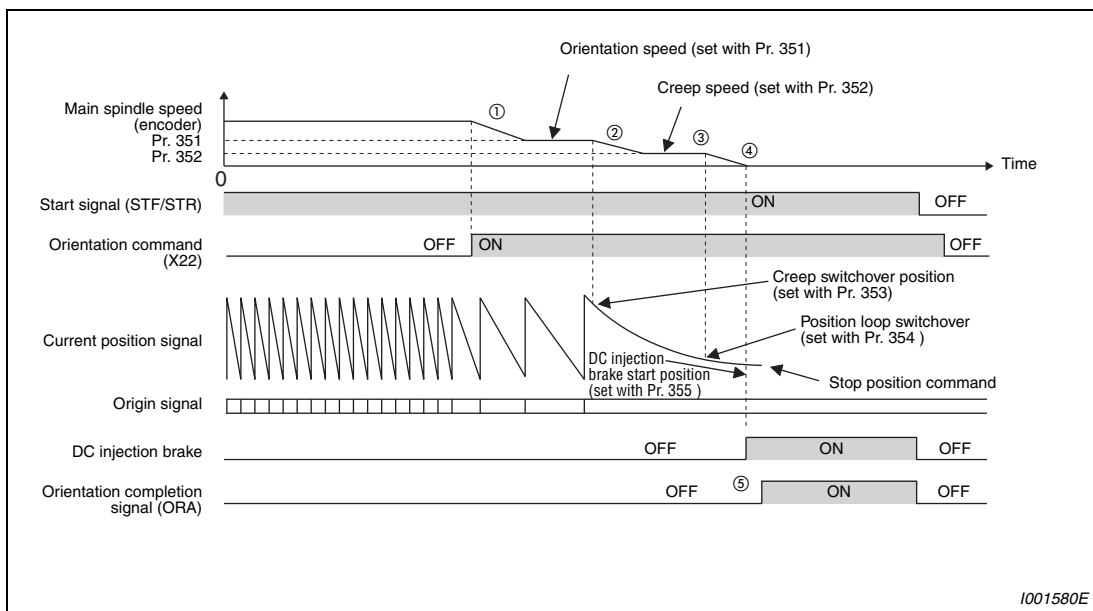
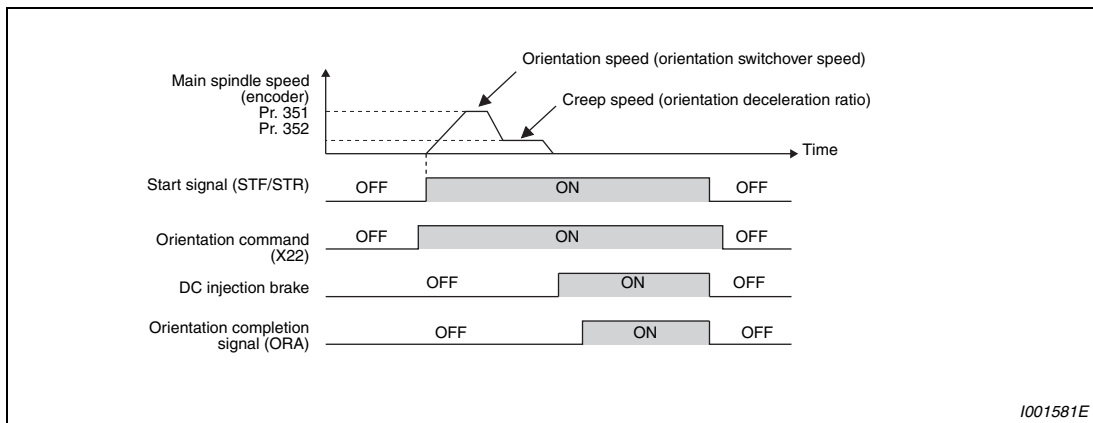

**Fig. 6-118:** Action time chart for orientation during running

● Orientation from stop

After turning on the orientation command (X22), turning on the start signal will increase the motor speed to the orientation speed set in Pr. 351 "Orientation speed", then orientation operation same as when "orientation during running" is performed (refer to ② to ④ at page 6-277).

Note that, DC injection brake is operated if the position signal is within the DC injection brake start position.



**Fig. 6-119:** Action time chart for orientation from stop

● Continuous multi-point orientation

Orientation command and orientation with STF/STR on (Orientation in servo in status).

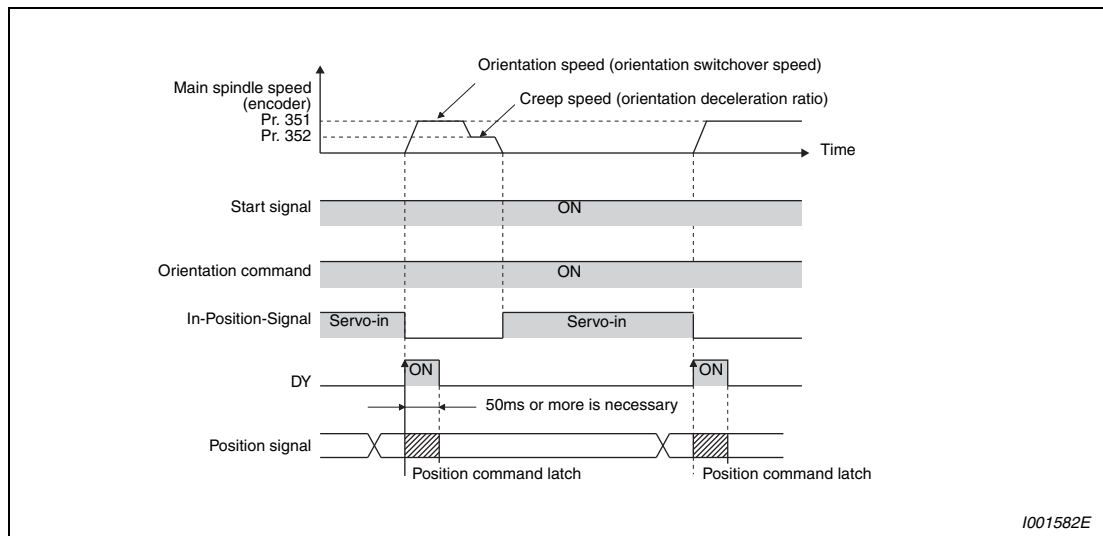

**Fig. 6-120:** Continuous multi-point orientation

**NOTES**

Read the position data at starting up of DY (refer to the FR-A7AX instruction manual ).

When the position signal is within the creep switchover position, the speed starts up to the creep speed not to the orientation speed.

When the position signal is not within the creep switchover position, the speed starts up to the orientation speed.

The DC injection brake is operated if the position signal is within the DC injection brake start position.

16-bit data with the FR-A7AX is valid only when the DY signal is on.

Please observe the following points when an encoder is used for orientation under V/f control or advanced magnetic flux vector control.

- The encoder should be coupled with the motor shaft or main spindle oriented with a speed ratio of 1 to 1 without any mechanical looseness.
- DC injection brake operates when orientation stop is made. Release the DC injection brake in a time as short as possible (within several seconds) since continuous operation of the DC injection brake will cause the motor to overheat, leading to burnout.
- Since no servo lock function is available after orientation stop, provide a holding mechanism such as mechanical brake or knock pin when secure holding of a main spindle is required.
- To ensure correct positioning, the encoder must be set in the proper rotation direction and the A and B phases connected correctly.
- When the pulse signal from the encoder stops due to the encoder signal loss, etc. during orientation, the orientation fault signal (ORM) may be output.
- When the DC injection brake is set to disabled using parameter for DC injection brake adjustment (voltage, frequency, speed, time) when performing orientation control, orientation operation can not be completed. Always set the DC injection brake enabled.
- To terminate orientation, the start signal (STF or STR) must be first switched off and the orientation signal (X22) must be switched off. As soon as this orientation signal is switched off, orientation control ends. (Depending on the Pr. 358 "Servo torque selection" setting, orientation status continues if the orientation signal remains on even if DC injection brake is released at turning off of the start signal. Therefore, the orientation status of the monitor function is not 0.)
- When retry function of Pr. 358 "Servo torque selection" is selected, this retry function is performed three times including the first orientation.
- When performing orientation control, make proper setting of Pr. 350 "Stop position command selection" and Pr. 360 "16 bit data selection (external position command selection)". If the values set are incorrect, proper orientation control will not be performed.
- When Pr. 11 "DC injection brake operation time" = "8888" (DC injection brake external selection), DC injection brake does not operate if the X13 signal is not turned on. Note that the DC injection brake is applied under orientation control regardless of the X13 signal status.
- When orientation control is exercised, PID control is invalid.



● Servo torque selection (Pr. 358)

Valid only under V/f control and advanced magnetic flux vector control.

Function	Pr. 358 Setting													Remarks	
	0	1	2	3	4	5	6	7	8	9	10	11	12		13
Servo torque function selection until output of the orientation completion signal (ORA) <sup>①</sup>	×	○	○	○	○	×	○	×	○	×	○	×	×	○	○: With servo torque function ×: Without servo torque function
Retry function selection <sup>②</sup>	×	×	×	×	×	×	×	○	×	×	×	○	×	×	○: With retry function ×: Without retry function
Output frequency is compensated when the motor stops outside the in-position zone c	×	×	○	○	×	○	○	×	×	×	×	×	○	○	○: With frequency compensation ×: Without frequency compensation
DC injection brake and servo torque selection when the position pulse comes off the in-position zone after output of the orientation completion signal (ORA) <sup>④</sup>	○	×	×	×	×	○	○	○	○	○	○	○	○	○	○: With DC injection brake ×: With servo torque
End switch selection of the DC injection brake and orientation completion signal (ORA) <sup>⑤</sup>	○	○	○	×	×	○	○	○	○	×	×	×	×	×	○: When the start signal (STF, STR) or orientation command is turned off ×: When the orientation command is turned off
Completion signal off selection when the position pulse comes off the in-position zone after output of the orientation completion signal (ORA) <sup>⑥</sup>	○	○	○	○	○	×	×	×	×	×	×	×	×	×	○: Turns off the completion signal when the motor stops outside of the in-position zone. ×: Completion signal remains on even if the position pulse comes off the completion zone (orientation fault signal (ORM) is not output)

**Tab. 6-78:** Settings of parameter 358

**NOTES**

When the orientation command is off with the start signal on, the speed accelerates to the command speed.

When the motor shaft stops outside of the set setting range of stop position, the motor shaft is returned to the stop position by servo torque function (if enough torque is generated).

Description of the functions listed in Tab. 6-78.

① Servo torque function selection until output of the orientation completion signal  
Whether servo torque is available or not is selected using Pr. 358 "Servo torque selection". Servo torque is not generated if the current position pulse is in between the orientation stop position and DC injection brake start position. Although, the shaft is retained by the DC injection brake, servo torque is generated to return the shaft within the width if the shaft moves out of the width by external force, etc. Once the orientation completion signal (ORA) is output, the motor runs according to the setting made in 4).

② Retry function selection  
Select retry function using Pr. 358 "Servo torque selection". Note that servo torque function can not be used together. When the motor shaft is not stopped within the in-position zone when the motor stop is checked, orientation operation is performed again by retry function. With this retry function, three orientations including the first one are performed. More than three times retry operations are not made. (The orientation fault signal (ORM) is not output during retry operation).

- ③ Frequency compensation function when the motor stops outside the orientation in-position zone  
When the motor stops before entering the in-position zone due to external force, etc., output frequency is increased to move the shaft to the orientation stop position. The output frequency is gradually increased to the creep speed of Pr. 352 "Creep speed". Note that this function and the retry function can not be used together.
- ④ DC injection brake and servo torque selection when the position pulse comes off the in-position zone after output of the orientation completion signal (ORA)  
If the position pulse comes off the orientation in-position width, you can select a setting either fixing a shaft with the DC injection brake or returning the motor to the orientation stop position with servo torque.
- ⑤ Orientation operation end switch operation selection between DC injection brake or servo torque  
When ending the orientation operation, turn off the start signal (STF or STR), then turn off the orientation command (X22). At this time, you can select when to turn off the orientation completion signal (ORA) from between at turning off of the start signal or turning off of the orientation command signal.
- ⑥ Selection of completion signal off or on when the motor stops outside of the in-position zone after output of the orientation completion signal (ORA)  
You can select the mode to turn off the completion signal or keep the completion signal on (orientation fault signal (ORM) is not output) when the motor stops outside of the in-position zone.

● Position loop gain (Pr. 362)

When servo torque function is selected using Pr. 358 "Servo torque selection", output frequency for generating servo torque increases to the creep speed of Pr. 352 "Creep speed" gradually according to the slope set in Pr. 362 "Orientation position loop gain".

Although the operation becomes faster when the value is increased, a machine may hunt, etc.

**Orientation operation explanation (during vector control)**

- Setting the rotation direction (Pr. 393 "Orientation selection")

Pr. 393	Rotation Direction	Remarks
0 (Initial value)	Pre-orientation	Orientation is executed from the current rotation direction.
1	Forward rotation	Orientation is executed from the forward rotation direction. (If the motor is running in reverse, orientation is executed from the forward rotation direction after deceleration.)
2	Reverse rotation	Orientation is executed from the reverse rotation direction. (If the motor is running in forward, orientation is executed from the reverse rotation direction after deceleration.)

**Tab. 6-79: Setting of parameter 393**

- Orientation from the current rotation direction

When the orientation command (X22) is input, the motor speed will decelerate from the running speed to Pr. 351 "Orientation speed". At the same time, the orientation stop position command will be read in. (The stop position command is determined by the setting of Pr. 350 and Pr.360. Refer to the figure below.)

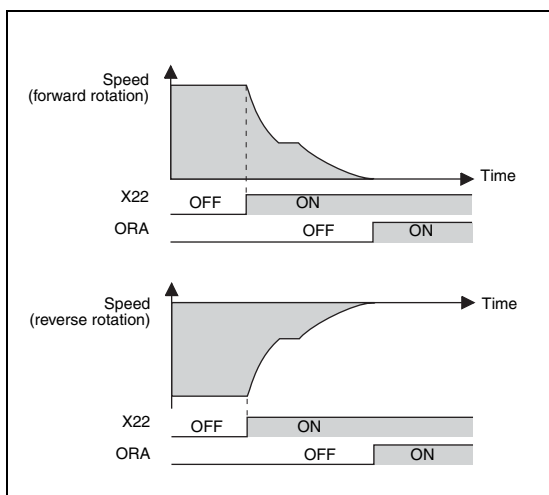

**Fig. 6-121:**  
Orientation from the current rotation direction

1001583E

When the orientation switchover speed is reached, the encoder Z phase pulse will be confirmed, and the mode will change from speed control to position control (Pr. 362 "Orientation position loop gain").

The distance to the orientation stop position is calculated at switching of the control, and the motor decelerates and stops with a set deceleration pattern (Pr. 399) and the orientation (servo lock) state will be entered.

When entered in the Pr. 357 "Orientation in-position zone", the orientation completion signal (ORA) will be output.

The zero point position (origin) can be moved using Pr. 361 "Position shift".



**CAUTION:**

**If the orientation command (X22) is turned off while the start signal is input, the motor will accelerate toward the speed of the current speed command. Thus, to stop, turn the forward rotation (reverse rotation) signal off.**

● Orientation from the forward rotation direction

This method is used to improve the stopping precision and maintain the mechanical precision when the backlash is large.

If the motor is running in the forward rotation direction, it will make an orientation stop with the same method as "orientation from the current rotation direction".

If the motor is running in reverse, it will decelerate, the rotation direction will be changed to forward run, and then orientation stop will be executed.

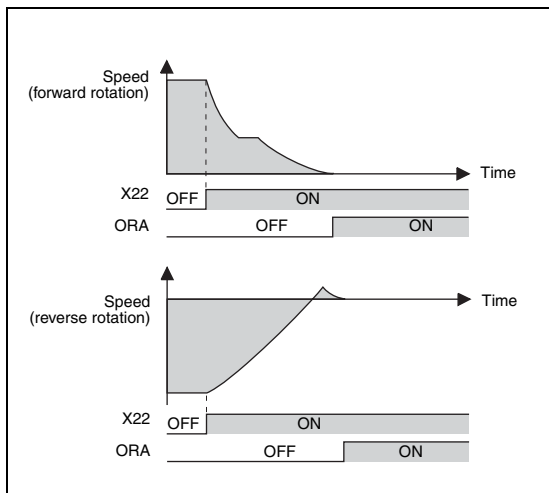

**Fig. 6-122:**  
Orientation from the forward rotation direction

I001585E

● Orientation from the reverse rotation direction

If the motor is running in the reverse rotation direction, it will make an orientation stop with the same method as "orientation from the current rotation direction".

If the motor is running in forward, it will decelerate, the rotation direction will be changed to reverse run, and then orientation stop will be executed.

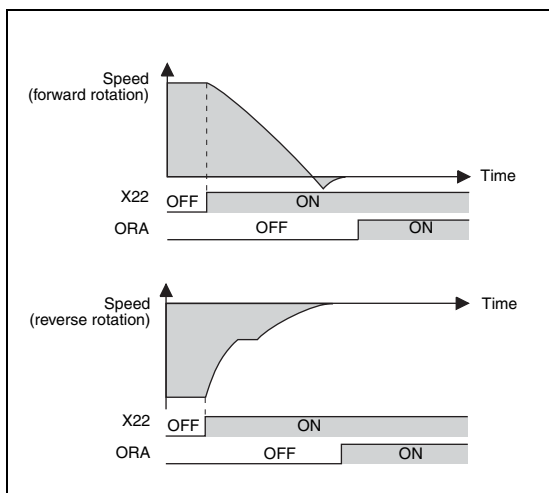

**Fig. 6-123:**  
Orientation from the reverse rotation direction

I001587E

Please observe the following points when an encoder is used for orientation under vector control.

- The encoder should be coupled with the motor shaft oriented with a speed ratio of 1 to 1 without any mechanical looseness.
- To ensure correct positioning, the encoder must be set in the proper rotation direction and the A and B phases connected correctly.
- Orientation may not be completed if the pulse signals are not received from the encoder during orientation due to a break in the cable or the like.
- To terminate orientation, the start signal (STF or STR) must be first switched off and the orientation signal (X22) must be switched off. As soon as this orientation signal is switched off, orientation control ends.
- When performing orientation control, make proper setting of Pr. 350 "Stop position command selection" and Pr. 360 "16 bit data selection". If the values set are incorrect, proper orientation control will not be performed.
- When orientation control is exercised, PID control is invalid.

**NOTE**

If "E.ECT" (no encoder signal) is displayed causing the inverter to trip when the orient signal (X22) is ON, check for a break in the cable of the Z phase of the encoder.

- Servo rigidity adjustment (Pr. 362, Pr. 396 to Pr. 398)

To increase the servo rigidity<sup>①</sup> during orientation stop using Pr. 396 or Pr. 397, adjust with the following procedures.

- ① Increase the Pr. 362 "Orientation position loop gain" value to the extent that rocking<sup>②</sup> does not occur during orientation stop.
- ② Increase Pr. 396 and Pr. 397 at the same rate.  
Generally adjust Pr. 396 in the range from 10 to 100, and Pr. 397 from 0.1 to 1.0s. (Note that these do not need to be set to the same rate.)

**EXAMPLE**

When the Pr. 396 value is multiplied by 1.2, divide the Pr. 397 value by 1.2. If vibration occurs during orientation stop, the scale cannot be raised any higher.

△

- ③ Pr. 398 is the lag/advance compensation gain.  
The limit cycle<sup>③</sup> can be prevented by increasing the value, and the running can be stopped stably. However, the torque in regard to the position deviation will drop, and the motor will stop with deviation.

















**NOTE**

Application of lag/advance control and PI control  
PI control can be applied by setting Pr. 398 to 0. Normally, the lag/advance control is selected. Note that PI control should be used when using a machine with a high spindle stationary friction torque and requires a stopping position precision.

- ① Servo rigidity: This is the response when a position control loop is configured.  
When the servo rigidity is raised, the holding force will increase, the running will stabilize, but vibration will occur easily.  
When the servo rigidity is lowered, the holding force will drop, and the setting time will increase.
- ② Rocking: Movement in which return occurs if the stopping position is exceeded.
- ③ Limit cycle: This is a phenomenon that generates  $\pm$  continuous vibration centering on the target position.

● Orientation deceleration ratio (Pr. 399, Initial value: 20)

Make adjustments as shown below according to the orientation status. (Refer to the Pr. 396 and Pr. 397 details also.) Generally adjust Pr. 362 in the range from 5 to 20, and Pr. 399 from 5 to 50.

Phenomenon	Adjustment Procedure			
	Pr. 396	Pr. 397	Pr. 398	Pr. 399
Rocking occurs during stopping	③ 	③ 	② 	① 
The orientation time is long			② 	① 
Hunting occurs when stopping	② 	② 	① 	
Zu niedrige Steifheit beim Stoppvorgang	① 	① 	② 	

**Tab. 6-80:** Adjustment of parameters 396 to 399

**NOTES**

The arrows in the above table have the following meanings:



: Increase the parameter setting value.

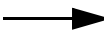

: Do not change the parameter setting value.



: Decrease the parameter setting value.

The numbers ①, ② and ③ in the table show the order of priority for changing the parameters setting value.



**CAUTION:**

Or, if the motor does forward/reverse reciprocation operation  the parameter setting value for the orientation detector installation direction may be incorrect. Review Pr. 393 "Orientation selection" (refer to page 6-271) and Pr. 359 "Encoder rotation direction" (refer to page 6-269).

● Orientation speed (Pr. 351, Initial value: 2Hz)

Set the speed when switching between the speed control mode and the position control mode is performed under orientation operation. Decreasing the set speed enables stable orientation stop. Note that the orientation time will increase.

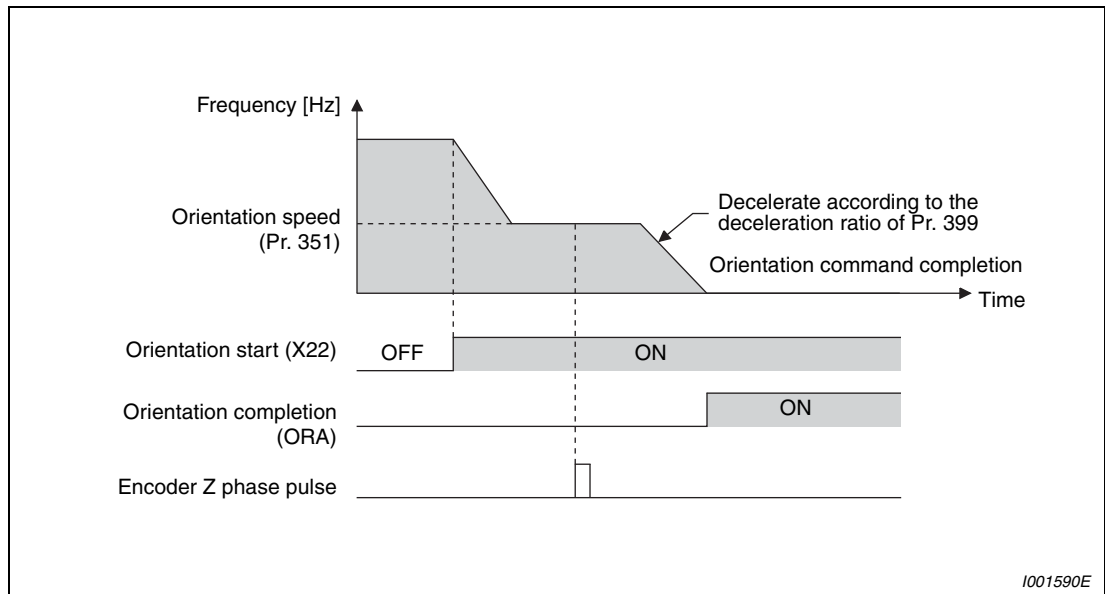

**Fig. 6-124:** Orientation speed

**NOTE**

When "19" is set in Pr. 52 "DU/PU main display data selection", position pulse monitor is displayed instead of PU output voltage monitor.



## 6.14 Function assignment of external terminals

Purpose	Parameters that must be set		Refer to Section
Assign function to input terminal	Input terminal function selection	Pr. 178–Pr. 189	6.14.1
Set MRS signal (output shutoff) to normally closed contact specification	MRS input selection	Pr. 17	6.14.2
Make the second function valid only during constant speed operation	RT reflection time selection	Pr. 155	6.14.3
Assign start signal and forward/reverse command to other signals	Start signal (STF/STR) operation selection	Pr. 250	6.14.4
Assign function to output terminal	Output terminal function selection	Pr. 190–Pr. 196	6.14.5
Detect output frequency	Up-to-frequency sensitivity Output frequency detection	Pr. 41–Pr. 43, Pr. 50, Pr. 116, Pr. 865	6.14.6
Detect output current	Output current detection Zero current detection	Pr. 150–Pr. 153, Pr. 166, Pr. 167	6.14.7
Remote output function	Remote output	Pr. 495–Pr. 497	6.14.9
Detect output torque	Output torque detection	Pr. 864	6.14.8

### 6.14.1 Input terminal function selection (Pr. 178 to Pr. 189)

Use these parameters to select/change the input terminal functions.

Pr. No.	Name	Initial Value	Initial Signal	Setting Range	Parameters referred to	Refer to Section
<b>178</b>	STF terminal function selection	60	STF (forward rotation command)	0–20/22–28/37/42–44/50/60/62/64–71/74/9999	—	
<b>179</b>	STR terminal function selection	61	STR (reverse rotation command)	0–20/22–28/37/42–44/50/61/62/64–71/74/9999		
<b>180</b>	RL terminal function selection	0	RL (low-speed operation command)	0–20/22–28/37/42–44/50/62/64–71/74/9999		
<b>181</b>	RM terminal function selection	1	RM (middle-speed operation command)			
<b>182</b>	RH terminal function selection	2	RH (high speed operation command)			
<b>183</b>	RT terminal function selection	3	RT (second function selection)			
<b>184</b>	AU terminal function selection	4	AU (terminal 4 input selection)	0–20/22–28/37/42–44/50/62–71/74/9999		
<b>185</b>	JOG terminal function selection	5	JOG (Jog operation selection)			
<b>186</b>	CS terminal function selection	6	CS (selection of automatic restart after instantaneous power failure)			
<b>187</b>	MRS terminal function selection	24	MRS (output stop)			
<b>188</b>	STOP terminal function selection	25	STOP (start self-holding selection)			
<b>189</b>	RES terminal function selection	62	RES (inverter reset)			

## Input terminal function assignment

Setting	Terminal	Function	Related Parameters	Refer to Page	
0	RL	Pr. 59 = 0 (Initial value)	Low-speed operation command	Pr. 4–Pr. 6, Pr. 24–Pr. 27, Pr. 232–Pr. 239	6-183
		Pr. 59 = 1, 2 ①	Remote setting (setting clear)	Pr. 59	6-191
		Pr. 270 = 1, 3 ①	Stop-on-contact selection 0	Pr. 270, Pr. 275, Pr. 276	6-259
1	RM	Pr. 59 = 0 (Initial value)	Middle-speed operation command	Pr. 4–Pr. 6, Pr. 24–Pr. 27, Pr. 232–Pr. 239	6-183
		Pr. 59 = 1, 2 ①	Remote setting (deceleration)	Pr. 59	6-191
2	RH	Pr. 59 = 0 (Initial value)	High-speed operation command	Pr. 4–Pr. 6, Pr. 24–Pr. 27, Pr. 232–Pr. 239	6-183
		Pr. 59 = 1, 2 ①	Remote setting (acceleration)	Pr. 59	6-191
3	RT	Second function selection		Pr. 44–Pr. 51	6-147, 6-155, 6-172, 6-195, 6-212, 6-312
		Pr. 270 = 1, 3 ②	Stop-on-contact selection 1	Pr. 270, Pr. 275, Pr. 276	6-259
4	AU	Terminal 4 input selection		Pr. 267	6-374
5	JOG	Jog operation selection		Pr. 15, Pr. 16	6-186
6	CS	Selection of automatic restart after instantaneous power failure, flying start		Pr. 57, Pr. 58, Pr. 162–Pr. 165, Pr. 299, Pr. 611	6-340
		Commercial power supply-inverter switchover function		Pr. 54, Pr. 58, Pr. 135–Pr. 139, Pr. 159	6-505
7	OH	External thermal relay input ②		Pr. 9	6-212
8	REX	15 speed selection (combination with three speeds RL, RM, RH)		Pr. 4–Pr. 6, Pr. 24–Pr. 27, Pr. 232–Pr. 239	6-183
9	X9	Third function selection		Pr. 110–Pr. 116	6-295
10	X10	Inverter operation enable signal (FR-HC, MT-HC, FR-CV connection)		Pr. 30, Pr. 70	6-249
11	X11	FR-HC or MT-HC connection, instantaneous power failure detection			
12	X12	PU operation external interlock		Pr. 79	6-418
13	X13	External DC injection brake operation start		Pr. 10–Pr. 12	6-241
14	X14	PID control valid terminal		Pr. 127–Pr. 134, Pr. 575–Pr. 577	6-491
15	BRI	Brake opening completion signal		Pr. 278–Pr. 285	6-264
16	X16	PU-external operation switchover		Pr. 79, Pr. 340	6-427
17	X17	Load pattern selection forward/reverse rotation boost		Pr. 14	6-175
18	X18	V/f switchover (V/f control is exercised when X18 is on)		Pr. 80, Pr. 81, Pr. 800	6-70, 6-150
19	X19	Load torque high-speed frequency		Pr. 270–Pr. 274	6-512
20	X20	S-shaped acceleration/deceleration C switching terminal		Pr. 380–Pr. 383	6-201
22	X22	Orientation command ④ ⑥		Pr. 350–Pr. 369	6-269
23	LX	Pre-excitation/servo on ⑤		Pr. 850	6-241
24	MRS	Output stop		Pr. 17	6-293
		Commercial power supply-inverter switchover function		Pr. 54, Pr. 58, Pr. 135–Pr. 139, Pr. 159	6-505
25	STOP	Start self-holding selection		—	6-297
26	MC	Control mode changing		Pr. 800	6-70
27	TL	Torque limit selection		Pr. 815	6-80

Tab. 6-81: Input terminal function assignment (1)

Setting	Terminal	Function	Related Parameters	Refer to Page
28	X28	Start-time tuning start external input	Pr. 95	6-236
37	X37	Traverse function selection	Pr. 592–Pr. 597	6-524
42	X42	Torque bias selection 1 <sup>⑥</sup>	Pr. 840–Pr. 845	6-102
43	X43	Torque bias selection 2 <sup>⑥</sup>		
44	X44	P/PI control switchover	Pr. 820, Pr. 821, Pr. 830, Pr. 831	6-88
50	SQ	Sequence start	Pr. 414–Pr. 417, Pr. 498, Pr. 506–Pr. 515	6-489
60	STF	Forward rotation command (assigned to STF terminal (Pr. 178) only)	—	6-297
61	STR	Reverse rotation command (assigned to STR terminal (Pr. 179) only)	—	6-297
62	RES	Inverter reset	—	—
63	PTC	PTC thermistor input (assigned to AU terminal (Pr. 184) only)	Pr. 9	6-217
64	X64	PID forward/reverse action switchover	Pr. 127–Pr. 134, Pr. 5	6-491
65	X65	PU-NET operation switching	Pr. 79, Pr. 340	6-430
66	X66	External/NET operation switchover		
67	X67	Command source switchover	Pr. 338, Pr. 339	6-432
68	NP	Conditional position pulse train sign <sup>⑥</sup>	Pr. 291, Pr. 419–Pr. 430, Pr. 464	6-134
69	CLR	Conditional position droop pulse clear <sup>⑥</sup>		
70	X70	DC feeding operation permission	Pr. 30, Pr. 70	6-249
71	X71	DC feeding cancel		
74	X74	Magnetic flux decay output shutoff	Pr. 850	6-244
9999	—	No function	—	—

**Tab. 6-82:** *Input terminal function assignment (2)*

- ① When Pr. 59 "Remote function selection" = 1 or 2, the functions of the RL, RM and RH signals change as listed above.
- ② When Pr. 270 "Stop-on contact control selection" = 1, 3, 11, or 13, functions of RL and RT signals are changed as in the table.
- ③ The OH signal turns on when the relay contact "opens".
- ④ The FR-A7AX (16-bit digital input) is needed to externally input a stop position under orientation control.
- ⑤ Servo ON is made valid during position control under vector control operation.
- ⑥ Available only when used with the FR-A7AP (option).

**NOTES**

Changing the terminal assignment using Pr. 178 to Pr. 189 "Input terminal function selection" may affect the other functions. Please make setting after confirming the function of each terminal.

One function can be assigned to two or more terminals. In this case, the terminal inputs are ORed.

The priorities of the speed commands are in order of jog, multi-speed setting (RH, RM, RL, REX) and PID (X14).

When the X10 signal (FR-HC, MT-HC, FR-CV connection - inverter operation enable signal) is not set, the MRS signal shares this function.

When the PU operation external interlock (X12) signal is not assigned at the Pr. 79 "Operation mode selection" setting of "7", the MRS signal shares this function.

Use common terminals to assign multi-speeds (speed 7) and remote setting. They cannot be set individually. (Common terminals are used since these functions are designed for speed setting and need not be set at the same time.)

When V/f switching (X18) signal and load pattern selection forward rotation reverse rotation boost (X17) signal are not assigned, the RT signal shares this function. (Pr. 81 "Number of motor poles" = "12, 14, 16, 18, 20"). In this case, V/f control is controlled by the second function.

**Response time of each signal**

The response time of the X10 signal is within 2ms. However, when the X10 signal is not assigned at the Pr. 30 "Regenerative function selection" setting of "2" (FR-HC/MT-HC/FR-CV connection), the response time of the MRS signal is within 2ms.

Pr. 17 "MRS input selection" is made invalid..

Pr. 30 Setting	MRS Assignment	X10 Assignment	Response Time		Pr. 17
			MRS	X10	
2	✓	—	≤ 2ms	—	Invalid
	—	✓	—	≤ 2ms	—
	✓	✓	≤ 20ms	≤ 2ms	Valid
Other than 2	✓	—	≤ 20ms	—	Valid
	—	✓	—	—	—
	✓	✓	≤ 20ms	—	Valid

**Tab. 6-83:** Response time of the signals MRS and X10

## 6.14.2 Inverter output shutoff signal (MRS signal, Pr. 17)

The inverter output can be shut off from the MRS signal. The logic of the MRS signal can also be selected.

Pr. No.	Name	Initial Value	Setting Range	Description	Parameters referred to	Refer to Section
17	MRS input selection	0	0	Open input always	178–189 Input terminal function selection	6.14.1
			2	Close input always (NC contact input specifications)		
			4	External terminal: Normally closed input (NC contact input specifications) Communication: Normally open input		

### Output shutoff signal

Turning on the output shutoff signal (MRS) during inverter running shuts off the output immediately.

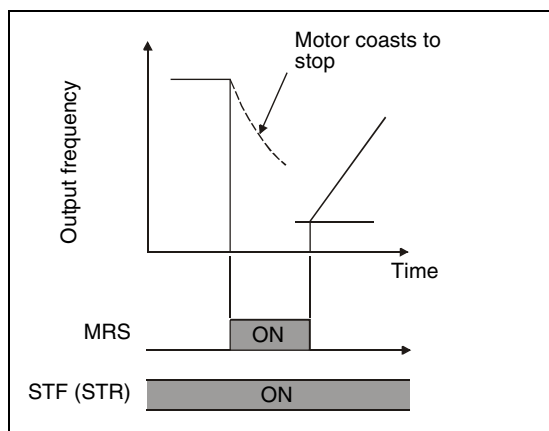

**Fig. 6-125:**  
Output shutoff signal

1001325C

Terminal MRS may be used as described below:

- When mechanical brake (e.g. electromagnetic brake) is used to stop motor. The inverter output is shut off when the mechanical brake operates.
- To provide interlock to disable operation by the inverter. With the MRS signal on, the inverter cannot be operated if the start signal is entered into the inverter.
- Coast the motor to a stop. When the start signal is turned off, the inverter decelerates the motor to a stop in the preset deceleration time, but when the MRS signal is turned on, the motor coasts to a stop.

**MRS signal logic inversion (Pr. 17 = 2)**

When Pr. 17 is set to "2", the MRS signal (output stop) can be changed to the normally closed (NC contact) input specification. When the MRS signal turns on (opens), the inverter shuts off the output.

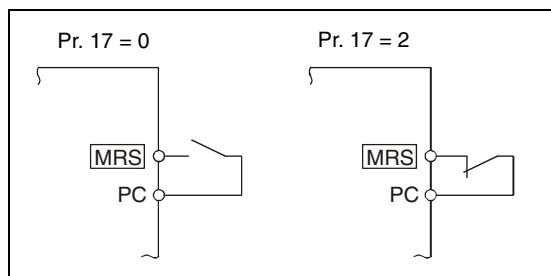

**Fig. 6-126:**  
Connection of the MRS terminal in source logic

1000011C

**Assign a different action for each MRS signal input from communication and external terminal (Pr. 17 = 4)**

When Pr. 17 is set to "4", the MRS signal from external terminal (output stop) can be changed to the normally closed (NC contact) input, and the MRS signal from communication can be changed to the normally open (NO contact) input.

This function is useful to perform operation by communication with MRS signal from external terminal remained on.

External MRS	Communication MRS	Pr. 17 Setting		
		0	2	4
OFF	OFF	Operation enabled	Output shutoff	Output shutoff
OFF	ON	Output shutoff	Output shutoff	Output shutoff
ON	OFF	Output shutoff	Output shutoff	Operation enabled
ON	ON	Output shutoff	Operation enabled	Output shutoff

**Tab. 6-84:** Output shutoff by external terminal or communication

**NOTES**

The MRS signal is assigned to the terminal MRS in the initial setting. By setting "24" in any of Pr. 178 to Pr. 189 "Input terminal function selection", the RT signal can be assigned to the other terminal.

The MRS signal can shut off the output, independently of the PU, external or network operation mode.

Changing the terminal assignment using Pr. 178 to Pr. 189 "Input terminal function selection" may affect the other functions. Please make setting after confirming the function of each terminal.

### 6.14.3 Condition selection of function validity by the second function selection signal (RT) and third function selection signal (X9) (RT signal, X9 signal, Pr. 155)

You can select the second (third) function using the RT(X9) signal.

You can also set the condition (reflection condition) where the second function and third function become valid.

Pr. No.	Name	Initial Value	Setting Range	Description	Parameters referred to	Refer to Section
155	RT signal function validity condition selection	0	0	Second (third) function is immediately made valid with on of the RT(X9) signal.	178-189 Input terminal function selection	6.14.1
			10	Second (third) function is valid only during the RT (X9) signal is on and constant speed operation. (invalid during acceleration/deceleration)		

When the RT signal turns on, the second function becomes valid.

When the X9 signal turns on, the third function becomes valid.

For the X9 signal, set "9" in any of Pr. 178 to Pr. 189 (input terminal function selection) to assign the function.

The second (third) function has the following applications:

- Switching between normal use and emergency use.
- Switching between heavy load and light load.
- Changing of acceleration/deceleration time by broken line acceleration/deceleration.
- Switching of characteristic between main motor and sub motor.

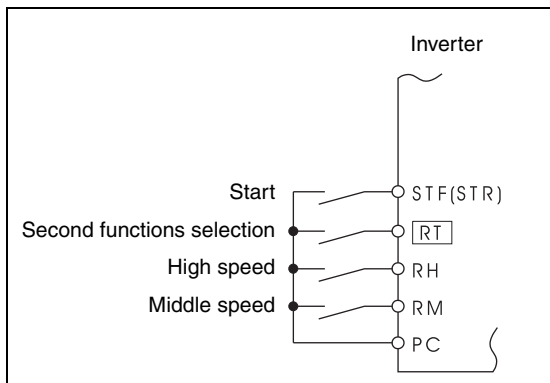

**Fig. 6-127:**  
Second functions connection diagram

1001145C

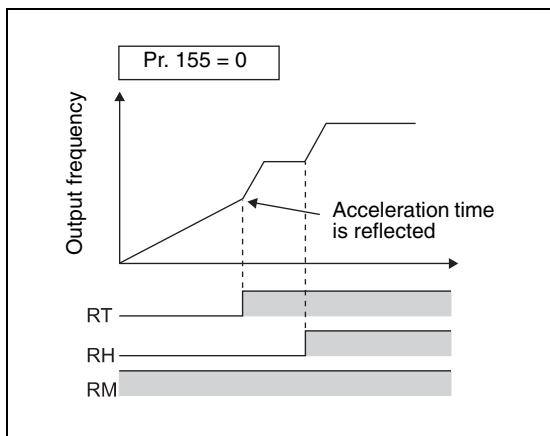

**Fig. 6-128:**  
Second acceleration/deceleration time example

1001146E

The following functions that can be set as second or third functions:

Funktion	Parameter Number as			Refer to Page
	First function	Second function	Third function	
Torque boost	Pr. 0	Pr. 46	Pr. 112	6-147
Base frequency	Pr. 3	Pr. 47	Pr. 113	6-172
Acceleration time	Pr. 7	Pr. 44	Pr. 110	6-195
Deceleration time	Pr. 8	Pr. 44, Pr. 45	Pr. 110, Pr. 111	6-195
Electronic thermal relay function	Pr. 9	Pr. 51	—	6-212
Stall prevention	Pr. 22	Pr. 48, Pr. 49	Pr. 114, Pr. 115	6-155
Applied motor	Pr. 71	Pr. 450	—	6-218
Motor constants	Pr. 80–Pr. 84, Pr. 89, Pr. 90–Pr. 94, Pr. 96, Pr. 859	Pr. 453–Pr. 457, Pr. 569, Pr. 458–Pr. 462, Pr. 463, Pr. 860	—	6-222
Online auto tuning selection	Pr. 95	Pr. 574	—	6-236
Motor control method	Pr. 800	Pr. 451	—	6-70
Speed control gain	Pr. 820, Pr. 821	Pr. 830, Pr. 831	—	6-88
Analog input filter	Pr. 822, Pr. 826	Pr. 832, Pr. 836	—	6-383
Speed detection filter	Pr. 823	Pr. 833	—	6-144
Torque control gain	Pr. 824, Pr. 825	Pr. 834, Pr. 835	—	6-124
Torque detection filter	Pr. 827	Pr. 837	—	6-144

**Tab. 6-85:** Functions that can be set as second or third functions

#### NOTES

The RT signal is assigned to the RT terminal in the initial setting. By setting "3" to any of Pr. 178 to Pr. 189 "Input terminal function selection", the RT signal can be assigned to the other terminal.

When the RT (X9) signal is on, the other functions such as the second (third) acceleration/ deceleration time are also selected.

Changing the terminal assignment using Pr. 178 to Pr. 189 "Input terminal function selection" may affect the other functions. Please make setting after confirming the function of each terminal.



### 6.14.4 Start signal selection (Terminal STF, STR, STOP, Pr. 250)

You can select the operation of the start signal (STF/STR).

Used to select the stopping method (deceleration to a stop or coasting) when the start signal turns off. Used to stop the motor with a mechanical brake, etc. together with switching off of the start signal. (Refer to section 6.13.3 for stop selection.)

Pr. No.	Name	Initial Value	Setting Range	Description		Parameters referred to	Refer to Section
				Start Signal (STF/STR)	Stop Operation		
250	Stop selection	9999	0-100s	STF: Forward rotation start STR: Reverse rotation start	The motor is coasted to a stop when the preset time elapses after the start signal is turned off.	4-6 Multi-speed setting 178-189 Input terminal function selection	6.10.1 6.14.1
			1000s-1100s	STF: Start signal STR: Forward/reverse signal			
			9999	STF: Forward rotation start STR: Reverse rotation start	When the start signal is turned off, the motor decelerates to stop.		
			8888	STF: Start signal STR: Forward/reverse signal			

#### 2-wire type (terminals STF and STR)

A two-wire type connection is shown below.

In the initial setting, the forward/reverse rotation signals (STF/STR) are used as start and stop signals. Turn on either of the forward and reverse rotation signals to start the motor in the corresponding direction. If both are turned off (or on) during operation, the inverter decelerates to a stop.

The speed setting signal may either be given by entering 0 to 10V DC across the speed setting input terminal 2-5, by setting the required values in Pr. 4 to Pr. 6 "Multi-speed setting" (high, middle, low speeds), etc. (For multi-speed operation, refer to section 6.10.1.)

When Pr. 250 is set to any of "1000 to 1100, 8888", the STF signal becomes a start command and the STR signal a forward/reverse command.

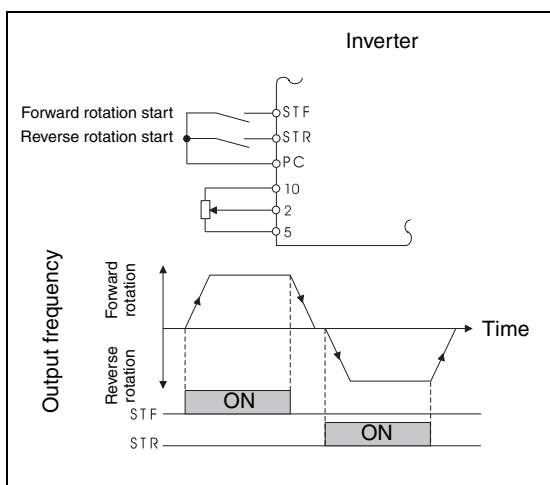

**Fig. 6-129:**  
2-wire type connection (Pr. 250 = 9999)

1001148E

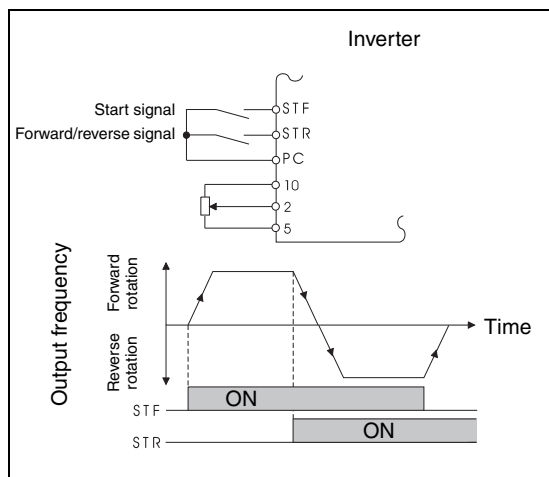

**Fig. 6-130:**  
2-wire type connection (Pr. 250 = 8888)

I001149E

#### NOTES

When Pr. 250 is set to any of "0 to 100, 1000 to 1100", the motor coasts to a stop if the start command is turned off. (Refer to section 6.13.3.)

The STF and STR signals are assigned to the STF and STR terminals in the initial setting. The STF signal can be assigned to Pr. 178 "STF terminal function selection" and the STR signal to Pr. 179 "STR terminal function selection" only.

Changing the terminal assignment using Pr. 178 to Pr. 189 "Input terminal function selection" may affect the other functions. Please make setting after confirming the function of each terminal.

### 3-wire type (terminals STF, STR and STOP)

A three-wire type connection is shown below.

The start self-holding selection becomes valid when the STOP signal is turned on. In this case, the forward/reverse rotation signal functions only as a start signal.

If the start signal (STF or STR) is turned on and then off, the start signal is held and makes a start. When changing the direction of rotation, turn STR (STF) on once and then off. To stop the inverter, turning off the STOP signal once decelerates it to a stop.

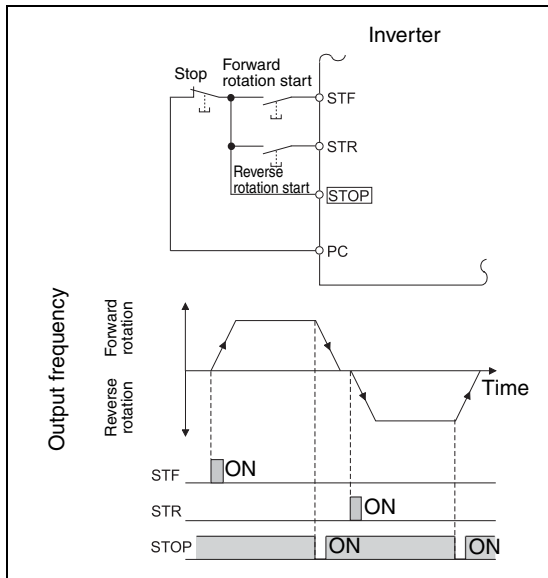

**Fig. 6-131:**  
3-wire type connection (Pr. 250 = 9999)

I001150E

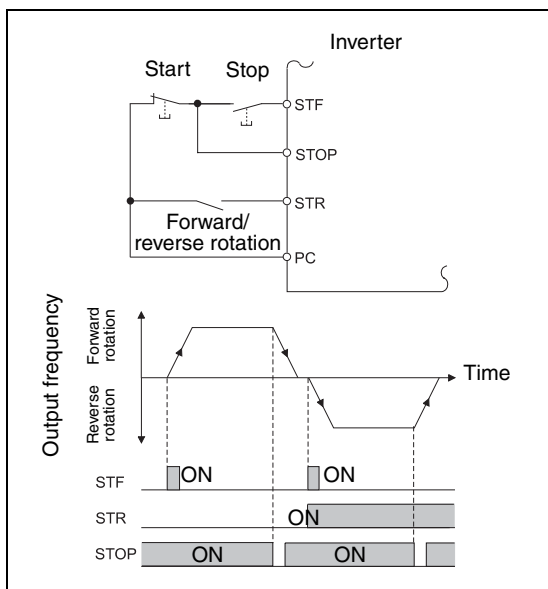

**Fig. 6-132:**  
3-wire type connection (Pr. 250 = 8888)

I001151E

#### NOTES

The STOP signal is assigned to the terminal STOP in the initial setting. By setting "25" in Pr. 178 to Pr. 189, the STOP signal can also be assigned to the other terminal.

When the JOG signal is turned on to enable jog operation, the STOP signal becomes invalid.

If the MRS signal is turned on to stop the output, the self-holding function is not cancelled.

**Start signal selection**

STF	STR	Setting Inverter Status	
		Pr. 250 = 0 to 100s/9999	Pr. 250 = 1000 to 1100s/8888
OFF	OFF	Stop	Stop
OFF	ON	Reverse rotation	
ON	OFF	Forward rotation	Forward rotation
ON	ON	Stop	Reverse rotation

**Tab. 6-86:** Start signal selection

## 6.14.5 Output terminal function selection (Pr. 190 to Pr. 196)

You can change the functions of the open collector output terminal and relay output terminal.

Pr. No.	Name	Initial Value	Initial Signal	Setting Range	Parameters referred to	Refer to Section
<b>190</b>	RUN terminal function selection	0	RUN (inverter running)	0-8/10-20/25-28/ 30-36/39/41-47/55/ 64/70/84/85/90-99/ 100-108/110-116/ 120/125-128/ 130-136/139/ 141-147/155/164/ 170/ 184/185/190-199/ 9999	13 Starting frequency	6.11.2
<b>191</b>	SU terminal function selection	1	SU (up to frequency)			
<b>192</b>	IPF terminal function selection	2	IPF (instantaneous power failure, under voltage)		76 Alarm code output selection	6.17.2
<b>193</b>	OL terminal function selection	3	OL (overload alarm)			
<b>194</b>	FU terminal function selection	4	FU (output frequency detection)			
<b>195</b>	ABC1 terminal function selection	99	ALM (alarm output)	0-8/10-20/25-28/ 30-36/39/41-47/55/ 64/70/84/85/90/91/ 94-99/100-108/ 110-116/120/ 125-128/130-136/ 139/141-147/155/ 164/170/184/185/ 190/191/194-199/ 9999		
<b>196</b>	ABC2 terminal function selection	9999	No function			

You can set the functions of the output terminals.  
Refer to the following table and set the parameters:  
0 to 99: Source logic  
100 to 199: Sink logic

Setting		Terminal	Function	Operation	Related Parameters	Refer to Page
Source Logic	Sink Logic					
0	100	RUN	Inverter running	Output during operation when the inverter output frequency rises to or above Pr. 13 "Starting frequency".	—	6-306
1	101	SU	Up to frequency <sup>①</sup>	Output when the output frequency is reached to the set frequency. <sup>③</sup>	Pr. 41	6-312
2	102	IPF	Instantaneous power failure/ under voltage	Output at occurrence of an instantaneous power failure or when under voltage protection is activated.	Pr. 57	6-340
3	103	OL	Overload alarm	Output while stall prevention function is activated.	Pr. 22, Pr. 23, Pr. 66, Pr. 148, Pr. 149, Pr. 154	6-155
4	104	FU	Output frequency detection	Output when the output frequency reaches the frequency setting in Pr. 42 (Pr. 43 for reverse rotation). <sup>③</sup>	Pr. 42, Pr. 43	6-312
5	105	FU2	Second output frequency detection	Output when the output frequency reaches the frequency setting in Pr. 50. <sup>③</sup>	Pr. 50	
6	106	FU3	Third output frequency detection	Output when the output frequency reaches the frequency set in Pr. 116 <sup>③</sup>	Pr. 116	

Tab. 6-87: Output terminal function assignment (1)

Setting		Terminal	Function	Operation	Related Parameters	Refer to Page
Source Logic	Sink Logic					
7	107	RBP	Regenerative brake prealarm	Output when 85% of the regenerative brake duty set in Pr. 70 is reached.	Pr. 70	6-249
8	108	THP	Electronic thermal relay function prealarm	Output when the electronic thermal relay function cumulative value reaches 85%. (Electronic thermal relay function protection (E.THT/ E.THM) activates, when the value reached 100%.)	Pr. 9	6-216
10	110	PU	PU operation mode	Output when the PU operation mode is selected.	Pr. 79	6-418
11	111	RY	Inverter operation ready	Output when the inverter can be started by switching the start signal on or while it is running.	—	6-306
12	112	Y12	Output current detection	Output when the output current is higher than the Pr. 150 setting for longer than the time set in Pr. 151.	Pr. 150, Pr. 151	6-315
13	113	Y13	Zero current detection	Output when the output power is lower than the Pr. 152 setting for longer than the time set in Pr. 153.	Pr. 152, Pr. 153	6-315
14	114	FDN	PID lower limit	Output when the feedback value falls below the lower limit of PID control.	Pr. 127–Pr. 134, Pr. 575–Pr. 577	6-491
15	115	FUP	PID upper limit	Output when the feedback value rises above the upper limit of PID control.		
16	116	RL	PID forward/reverse rotation output	Output when forward rotation is performed in PID control.		
17	—	MC1	Commercial power-supply switchover MC1	Used when the commercial power supply-inverter switchover function is used.	Pr. 135–Pr. 139, Pr. 159	6-505
18	—	MC2	Commercial power-supply switchover MC2			
19	—	MC3	Commercial power-supply switchover MC3			
20	120	BOF	Brake opening request	Output to open the brake when the brake sequence function is selected.	Pr. 278–Pr. 285, Pr. 292	6-264
25	125	FAN	Fan fault output	Output at the time of a fan fault.	Pr. 244	6-530
26	126	FIN	Heatsink overheat prealarm	Output when the heatsink temperature reaches about 85% of the heatsink overheat protection providing temperature.	—	7-14
27	127	ORA	Orientation in-position	When orientation is valid <sup>④</sup>	Pr. 350–Pr. 366, Pr. 369, Pr. 393, Pr. 396–Pr. 399	6-269
28	128	ORM	Orientation error			
30	130	Y30	Forward rotation output	Output when the motor is running in forward direction. <sup>④</sup>	—	6-309
31	131	Y31	Reverse rotation output	Output when the motor is running in reverse direction. <sup>④</sup>		
32	132	Y32	Regenerative status output	Output in the regenerative status under vector control operation. <sup>④</sup>		

**Tab. 6-87:** Output terminal function assignment (2)

Setting		Terminal	Function	Operation	Related Parameters	Refer to Page
Source Logic	Sink Logic					
33	133	RY2	Operation ready 2	Output during pre-excitation or operation under real sensorless vector control.	—	6-307
34	134	LS	Low speed output	Output when the output frequency reduces below the Pr. 865 setting.	Pr. 865	6-312
35	135	TU	Torque detection	Output when the motor torque rises above the Pr. 864 value.	Pr. 864	6-317
36	136	Y36	In-position	Output when the number of droop pulses has fallen below the setting value.	Pr. 426	6-140
39	139	Y39	Start time tuning completion	Output on completion of start-time tuning.	Pr. 95, Pr. 574	6-236
41	141	FB	Speed detection	Output when the actual motor speed (estimated actual speed value) reaches the Pr. 42 (Pr. 50, Pr.116) setting.	Pr. 42, Pr. 50, Pr. 116	6-312
42	142	FB2	Second speed detection			
43	143	FB3	Third speed detection			
44	144	RUN2	Inverter running	<ul style="list-style-type: none"> <li>• Output during forward rotation or the reverse rotation signal is ON.</li> <li>• Output at deceleration even during forward rotation or the reverse rotation signal is OFF. (Does not output during pre-excitation LX is ON.)</li> <li>• Output during the orientation command signal (X22) is ON.</li> <li>• Switched ON when the servo is ON (LXON) under position control. (Switched OFF when the servo is OFF (LX-OFF))</li> </ul>	—	6-306
45	145	RUN3	During inverter running and start command is on	Output when the inverter running and start commands are on.	—	6-306
46	146	Y46	During deceleration at occurrence of power failure (retained until release)	Output when the power failure-time deceleration function is executed.	Pr. 261–Pr. 266	6-349
47	147	PID	During PID control activated	Output during PID control.	Pr. 127–Pr. 134, Pr. 575–Pr. 577	6-491
55	155	Y55	Motor temperature detection signal	Detection of the motor temperature is available when a inverter manufactured in December 2010 or later is used in combination with a dedicated motor with thermistor and the option FR-A7AZ.	Pr. 750	—

**Tab. 6-87:** Output terminal function assignment (3)

Setting		Terminal	Function	Operation	Related Parameters	Refer to Page
Source Logic	Sink Logic					
64	164	Y64	During retry	Output during retry processing.	Pr. 65–Pr. 69	6-354
70	170	SLEEP	PID output interruption	Output when the PID output interruption function is executed.	Pr. 127–Pr. 134, Pr. 575–Pr. 577	6-491
84	184	RDY	Position control preparation ready	Signal is output when the servo is on (LX-ON) and ready to operate.	Pr. 419, Pr. 428–Pr. 430	6-134
85	185	Y85	DC feeding	This signal turns on during power failure or under voltage of AC power.	Pr. 30, Pr. 70	6-249
90	190	Y90	Life alarm	Output when any of the control circuit capacitor, main circuit capacitor and inrush current limit circuit or the cooling fan approaches the end of its service life.	Pr. 255–Pr. 259	6-531
91	191	Y91	Alarm output 3 (power-off signal)	Output when an error occurs due to the circuit failure or connection alarm of the inverter.	—	6-311
92	192	Y92	Energy saving average value updated timing	Turned on and off alternately every time the power saving average value is updated when the power saving monitor is used. Cannot be set to Pr. 195 and Pr. 196 (relay output terminal).	Pr. 52, Pr. 54, Pr. 158, Pr. 891–Pr. 899	6-363
93	193	Y93	Current average value monitor signal	Average current value and maintenance timer value are output as pulses. Cannot be set to Pr. 195 and Pr. 196 (relay output terminal).	Pr. 555–Pr. 557	6-536
94	194	ALM2 <sup>③</sup>	Alarm output 2	Output when the inverter's protective function is activated to stop the output (major fault). Continue outputting the signal during inverter reset and stop outputting after reset is cancelled. <sup>②</sup>	—	6-311
95	195	Y95	Maintenance timer signal	Output when Pr. 503 rises to or above the Pr. 504 setting.	Pr. 503, Pr. 504	6-535
96	196	REM	Remote output	Output to the terminal when a value is set to the parameter.	Pr. 495–Pr. 497	6-318

**Tab. 6-87:** Output terminal function assignment (4)



Setting		Terminal	Function	Operation	Related Parameters	Refer to Page
Source Logic	Sink Logic					
97	197	ER	Minor fault output 2	Output when the inverter protective function is activated to stop the output (major fault)	Pr. 875	6-361
98	198	LF	Minor fault output	Output when a minor fault (fan failure or communication error warning) occurs.	Pr. 121, Pr. 244	6-448, 6-530
99	199	ALM	Alarm output	Output when the inverter's protective function is activated to stop the output (major fault). The signal output is stopped when a reset turns on.	—	6-311
9999		—	No function	—	—	—

**Tab. 6-87:** Output terminal function assignment (5)

- ① Note that when the frequency setting is varied using an analog signal or the digital dial of the operation panel (FR-DU07), the output of the SU (up to frequency) signal may alternate on and off depending on that varying speed and the timing of the varying speed due to acceleration/deceleration time setting. (The output will not alternate on and off when the acceleration/deceleration time setting is "0s".)
- ② When a power supply reset is performed, the alarm output 2 signal (ALM2) turns off as soon as the power supply switches off.
- ③ Up to frequency SU, frequency detection FU, FU2, FU3 under encoder feed back control or vector control (option FR-A7AP is mounted) signals are as below.  
 SU, FU: Output when the actual speed (frequency) by the encoder feedback signal exceeds detected specification frequency.  
 FU2, FU3: Output when the inverter output frequency exceeds detected specification frequency..
- ④ This parameter is valid when the FR-A7AP (option) is mounted.

#### NOTES

- | The same function may be set to more than one terminal.
- | When the function is executed, the terminal conducts at the setting of any of "0" to "99", and does not conduct at the setting of any of "100" to "199".
- | The signal will not function if a value other than the above is set to any of Pr. 190 to Pr. 196.
- | When Pr. 76 "Alarm code output selection" = 1, the output signals of the terminals SU, IPF, OL and FU are switched as set in Pr. 76. (When an inverter alarm occurs, the signal output is switched to the alarm output.)
- | The output assignment of the terminal RUN and alarm output relay are as set above regardless of Pr. 76.
- | When terminal assignment is changed using Pr. 190 to Pr. 196 "Output terminal function selection", the other functions may be affected. Please make setting after confirming the function of each terminal.
- | Do not assign signals which repeat frequent ON/OFF to A1, B1, C1, A2, B2, C2. Otherwise, the life of the relay contact decreases.

**Inverter operation ready signal (RY, RY2 signal) and inverter running signal (RUN, RUN2, RUN3 signal) under V/f control and advanced magnetic flux vector control**

When the inverter is ready to operate, the output of the operation ready signal (RY) is on. It is also on during inverter running.

When the output frequency of the inverter rises to or above Pr. 13 "Starting frequency", the output of the inverter running signal (RUN) is turned on. During an inverter stop or DC injection brake operation, the output is off.

The output of the RUN3 signal is on when the inverter running and start signals are on. (For the RUN3 signal, output is on if the starting command is on even when the inverter protective function is activated or the MRS signal is on.)

The output is on during DC injection brake operation and off during an inverter stop.

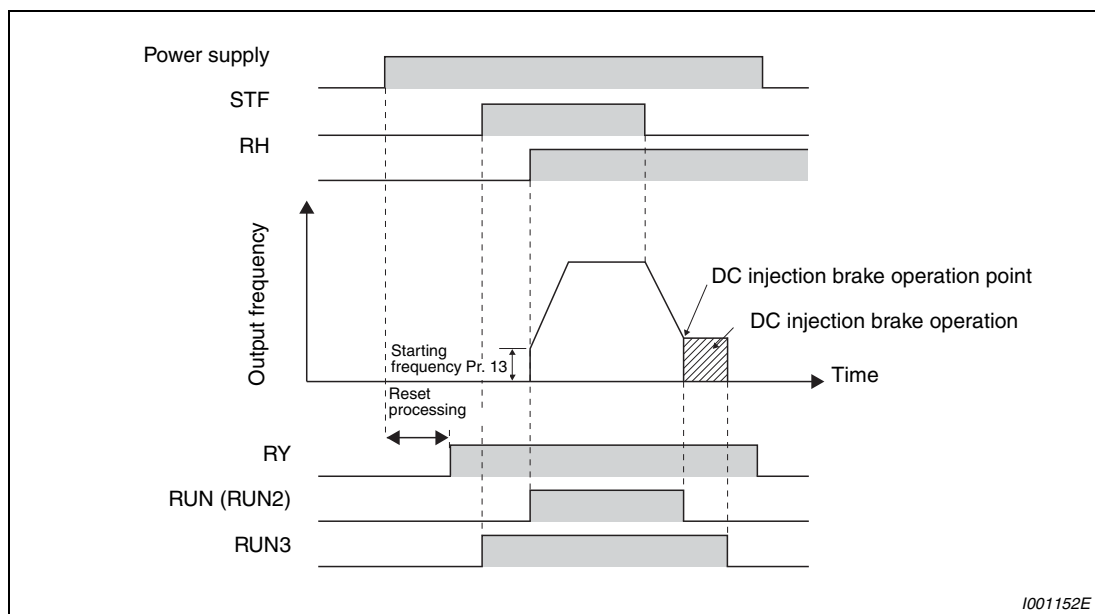

**Fig. 6-133: Ready and motor running signals**

Output Signal	Start Signal OFF (during stop)	Start Signal ON (during stop)	Start Signal ON (during operation)	Under DC Injection Brake	At Alarm Occurrence or MRS Signal ON (output shutoff)		Automatic Restart after Instantaneous Power Failure		
					Start Signal is ON	Start signal is OFF	Coasting		Restarting
							Start-signal EIN	Start-signal AUS	
RY	ON	ON	ON	ON	OFF	OFF	ON <sup>①</sup>	ON	
RY2	OFF	OFF	OFF	OFF	OFF	OFF	OFF	OFF	
RUN	OFF	OFF	ON	OFF	OFF	OFF	OFF	ON	
RUN2	OFF	OFF	ON	OFF	OFF	OFF	OFF	ON	
RUN3	OFF	ON	ON	ON	ON	AUS	ON	OFF	ON

**Tab. 6-88: Output signal output**

<sup>①</sup> This signal turns OFF during power failure or undervoltage.

**Inverter operation ready signal (RY, RY2 signal) and inverter running signal (RUN, RUN2, RUN3 signal) under real sensor less vector control and vector control**

When the inverter is ready to operate, the output of the operation ready signal (RY) is on. It is also on during inverter running.

When the inverter output frequency rises to or above the Pr. 13 "Starting frequency setting", the output of the inverter running signal (RUN) is turned on. During an inverter stop, DC injection brake operation, start time tuning or pre-excitation, the output is off.

For the RUN2 signal, the output is on while the inverter is running and the start signal is on. (For the RUN2 signal, the output is off when the inverter protective function is activated and the MRS signal is on.)

For the RUN3 signal, the output is on while the inverter is running and the start signal is on.

The RUN2 and RUN3 signals are on when the start command is on and even during pre-excitation with "0" set in speed command. (Note that the RUN2 signal turns off during preexcitation by turning the LX signal on.)

The RY2 signal turns on at the start of pre-excitation. The signal is on while pre-excitation is activated even during an inverter stop. The signal turns off while the output is shut off (MRS signal).

**NOTE**

For pre-excitation by pre-excitation signal (LX), the RY2 signal turns on when 100ms has elapsed after LX signal turn on (500ms for the 02160 or more).

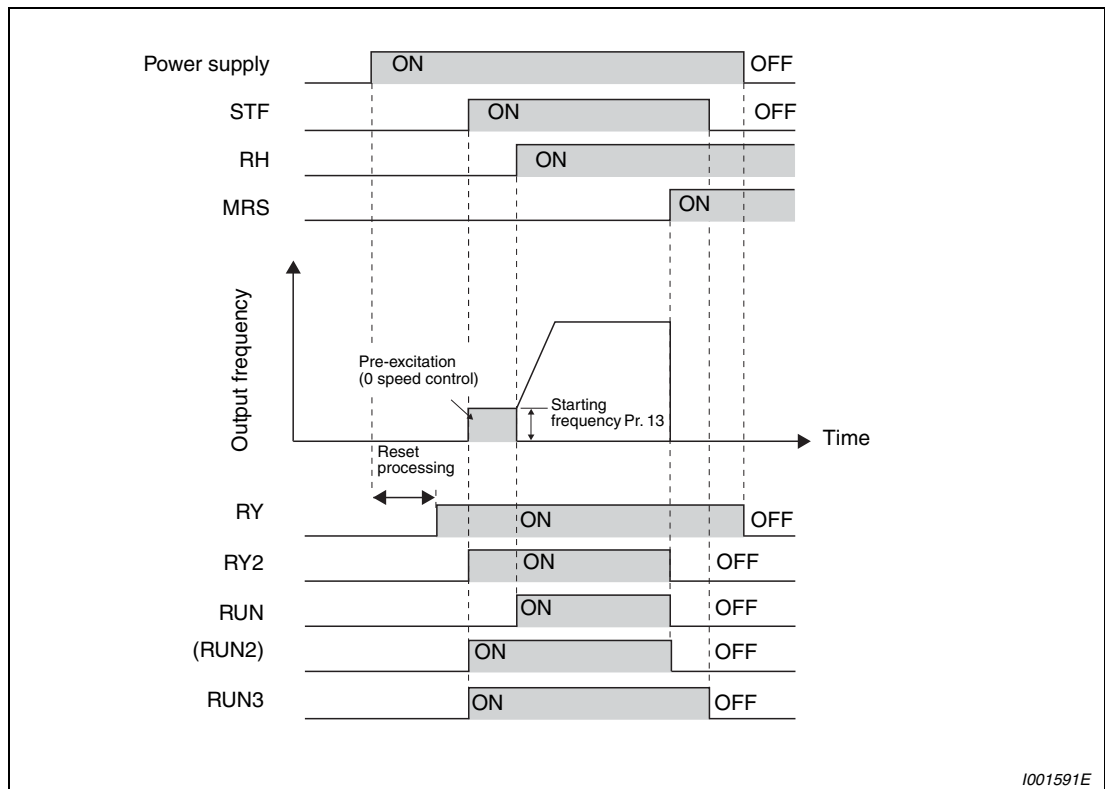
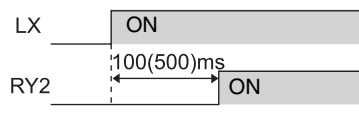

**Fig. 6-134: Ready and motor running signals**

Output Signal	Start Signal OFF (during stop)	Start Signal ON <sup>①</sup> (during stop)	Start Signal ON (during operation)	LX Signal is ON (preexcitation)	Under DC Injection Brake	At Alarm Occurrence or MRS Signal ON (output shutoff)		Automatic Restart after Instantaneous Power Failure		
						Start Signal is ON	Start signal is OFF	Coasting		Restarting
								Start Signal is ON	Start signal is OFF	
RY	ON	ON	ON	ON	ON	OFF		ON <sup>②</sup>		ON
RY2	OFF	ON	ON	ON <sup>③</sup>	ON	OFF		OFF		OFF
RUN	OFF	OFF	ON	OFF	OFF	OFF		OFF		ON
RUN2	OFF	ON	ON	OFF <sup>④</sup>	OFF	OFF		OFF		ON
RUN3	OFF	ON	ON	ON	ON	ON	OFF	ON	OFF	ON

**Tab. 6-89:** Output signal output

- ① Pre-excitation is made when the start signal is ON and frequency command is 0Hz.
- ② This signal turns OFF during power failure or undervoltage.
- ③ There is a delay of 100ms (500ms for the 02160 or more) when the signal is ON.
- ④ This signal turns ON during servo ON (LX signal is ON) under position control.

When using the RY, RY2, RUN, RUN2 and RUN3 signals, assign functions to Pr. 190 to Pr. 196 (output terminal selection function) referring to the table below.

Output signal	Pr. 190 to Pr. 196 Setting	
	Source logic	Sink logic
RY	11	111
RY2	33	133
RUN	0	100
RUN2	44	144
RUN3	45	145

**Tab. 6-90:** Assignment of the signals

**NOTE**

| The RUN signal is assigned to the terminal RUN in the initial setting.

### Forward rotation and reverse rotation signal (Y30, Y31)

The status during forward rotation (Y30) and reverse rotation (Y31) are output from the actual motor speed under vector control.

Y30 and Y31 signals turn off during pre-excitation (zero speed, servo lock) under speed control or torque control operation. Note that signals are output according to the motor rotation during servo lock under position control as same as inverter running.

When using the Y30 signal, set "30 (source logic) or 130 (sink logic)" to any of Pr. 190 to Pr. 196 (output terminal function selection) to assign the function to the output terminal.

When using the Y31 signal, set "31 (source logic) or 131 (sink logic)" to any of Pr. 190 to Pr. 196 (output terminal function selection) to assign the function to the output terminal.

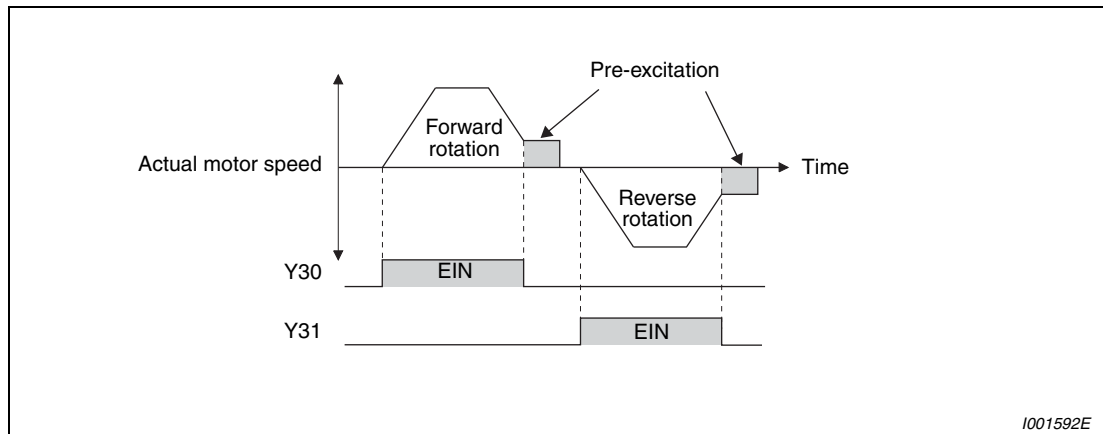

**Fig. 6-135:** Forward and reverse rotation of the motor

#### NOTES

This signal is always off during V/f control, advanced magnetic flux vector control or real sensorless vector control.

If the motor is made to run by external force, etc. during an inverter stop, Y30 and Y31 remain OFF.

The FR-A7AP (option) is necessary for vector control.

### Regenerative mode output signal (Y32 signal)

While the motor is in regenerative status (motor is in power regenerative status), the regenerative status output signal (Y32) is turned on. If the signal is turned on once, it will be retained for at least 100ms.

It turns off while the inverter is stopped and during preexcitation.

When using the Y32 signal, set "32 (source logic) or 132 (sink logic)" to any of Pr. 190 to Pr. 196 (output terminal function selection) to assign the function to the output terminal.

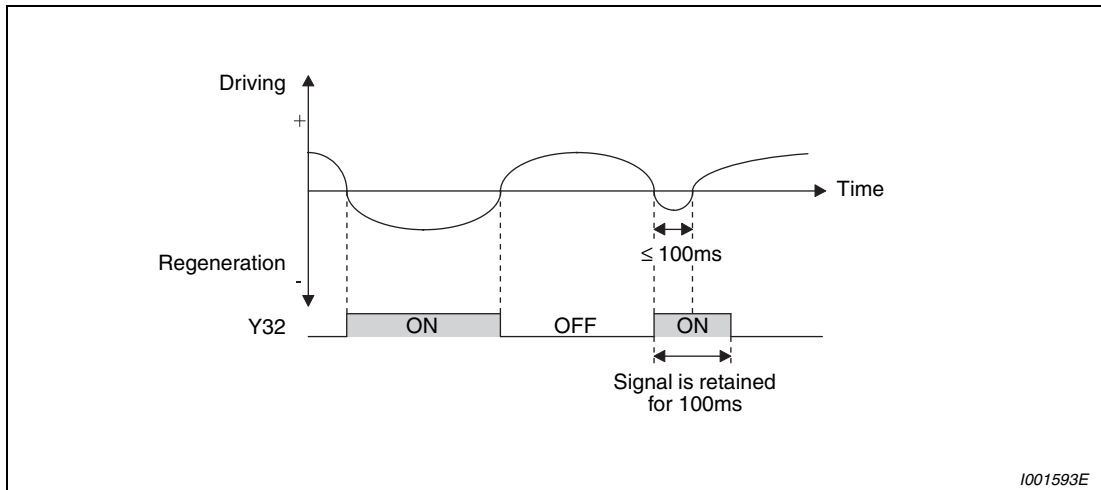

**Fig. 6-136:** Forward and reverse rotation of the motor

#### NOTES

This signal is always off during V/f control, advanced magnetic flux vector control or real sensorless vector control.

The FR-A7AP (option) is necessary for vector control.

**Alarm output signal (ALM, ALM2)**

If the inverter comes to an alarm stop, the ALM and ALM2 signals are output. (Refer to section 7.1 for the alarm description.)

The ALM2 signal remains on during a reset period after alarm occurrence. When using the ALM2 signal, set "94" (source logic) or "194" (sink logic) to any of Pr. 190 to Pr. 196 "Output terminal function selection" to assign the function to the output terminal.

The ALM signal is assigned to the A1, B1 and C1 contacts in the initial setting.

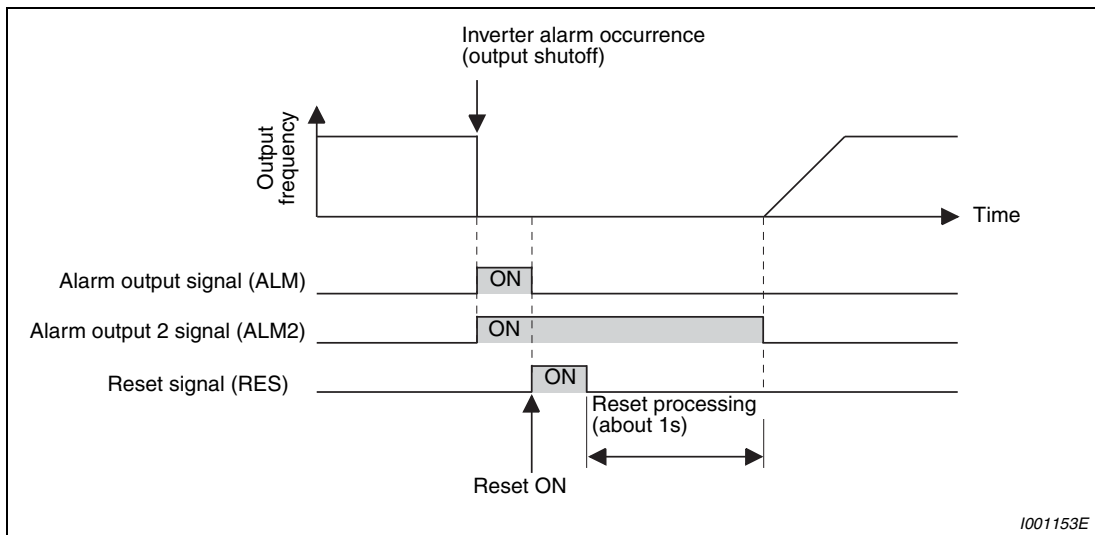

**Fig. 6-137: Alarm signals**

**Input MC shutoff signal (Y91)**

The Y91 signal is output at occurrence of an alarm attributable to the failure of the inverter circuit or an alarm caused by a wiring mistake. When using the Y91 signal, set "91 (source logic)" or "191 (sink logic)" to any of Pr. 190 to Pr. 196 "Output terminal function selection" to assign the function to the output terminal.

No.	Alarm Definition
1	Inrush current limit circuit alarm (E.IOH)
2	CPU error (E.CPU)
3	CPU error (E.E6)
4	CPU error (E.E7)
5	Parameter storage device alarm (E.PE)
6	Parameter storage device alarm (E.PE2)
7	24V DC internal power output short circuit (E.P24)
8	Operation panel power supply short circuit RS-485 terminal power supply short circuit (E.CTE)
9	Output side earth (ground) fault over current protection (E.GF)
10	Output phase failure (E.LF)
11	Opposite rotation deceleration error (E.BE)

**Tab. 6-91: Faults that lead to Y91 signal output**

## 6.14.6 Detection of output frequency (SU, FU, FU2, FU3, FB, FB2, FB3, LS, Pr. 41 to Pr. 43, Pr. 50, Pr. 116, Pr. 865)

The inverter output frequency is detected and output to the output signal.

Pr. No.	Name	Initial Value	Setting Range	Description	Parameters referred to	Refer to Section
<b>41</b>	Up-to-frequency sensitivity	10%	0–100%	Set the level where the SU signal turns on.	190–196 Output terminal function selection 874 OLT level setting	6.14.5 6.3.2
<b>42</b>	Output frequency detection	6Hz	0–400Hz	Set the frequency where the FU (FB) signal turns on.		
<b>43</b>	Output frequency detection for reverse rotation	9999	0–400Hz	Set the frequency where the FU (FB) signal turns on in reverse rotation.		
			9999	Same as Pr. 42 setting		
<b>50</b>	Second output frequency detection	30Hz	0–400Hz	Set the frequency where the FU2 (FB2) signal turns on.		
<b>116</b>	Third output frequency detection	50Hz	0–400Hz	Set the frequency where the FU3 (FB3) signal turns on.		
<b>865</b>	Low speed detection		0–400Hz	Set the frequency where the LS signal turns on.		

### Up-to-frequency sensitivity (SU, Pr. 41)

When the output frequency reaches the running frequency, the up-to-frequency signal (SU) is output. The Pr. 41 value can be adjusted within the range  $\pm 1\%$  to  $\pm 100\%$  on the assumption that the set frequency is 100%.

This parameter can be used to ensure that the running frequency has been reached to provide the operation start signal etc. for related equipment.

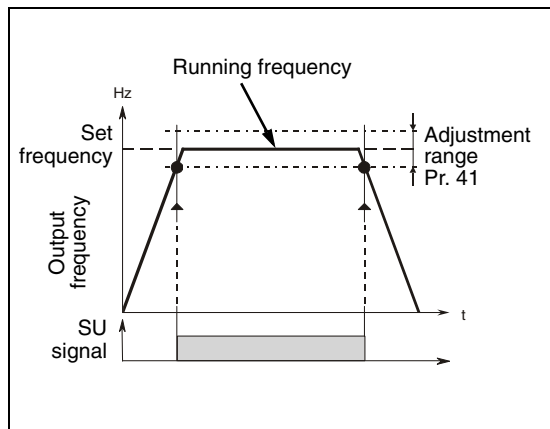

**Fig. 6-138:**  
Output of the SU signal

1000020C



**Output frequency detection (FU (FB) signal, FU2 (FB2) signal, FU3 (FB3) signal, Pr. 42, Pr. 43, Pr. 50, Pr. 116)**

When the output frequency rises to or above the Pr. 42 setting, the output frequency detection signal (FU) is output. This function can be used for electromagnetic brake operation, open signal, etc.

The FU (FU2, FU3) signal is output when the output frequency reaches the set frequency. While the FB (FB2, FB3) signal is output when the actual rotation detection speed (during real sensorless vector control : speed estimated value, during vector control : feedback value) of the motor reaches the set frequency. The FU signal and FB signal are output simultaneously during V/f control and advanced magnetic flux vector control.

When the detection frequency is set in Pr. 43, frequency detection used exclusively for reverse rotation can also be set. This function is effective for switching the timing of electromagnetic brake operation between forward rotation (rise) and reverse rotation (fall) during elevator operation, etc.

When Pr. 43 ≠ "9999", the Pr. 42 setting applies to forward rotation and the Pr. 43 setting applies to reverse rotation.

When outputting a frequency detection signal besides the FU signal, set the detection frequency in Pr. 50 or Pr. 116. The FU2 (FB2) signal (FU3 (FB3) signal if Pr. 116 or more) is output when the output frequency reaches or exceeds the Pr. 50 setting.

For each signal, assign functions to Pr. 190 to Pr. 196 "Output terminal function selection" referring to the table below..

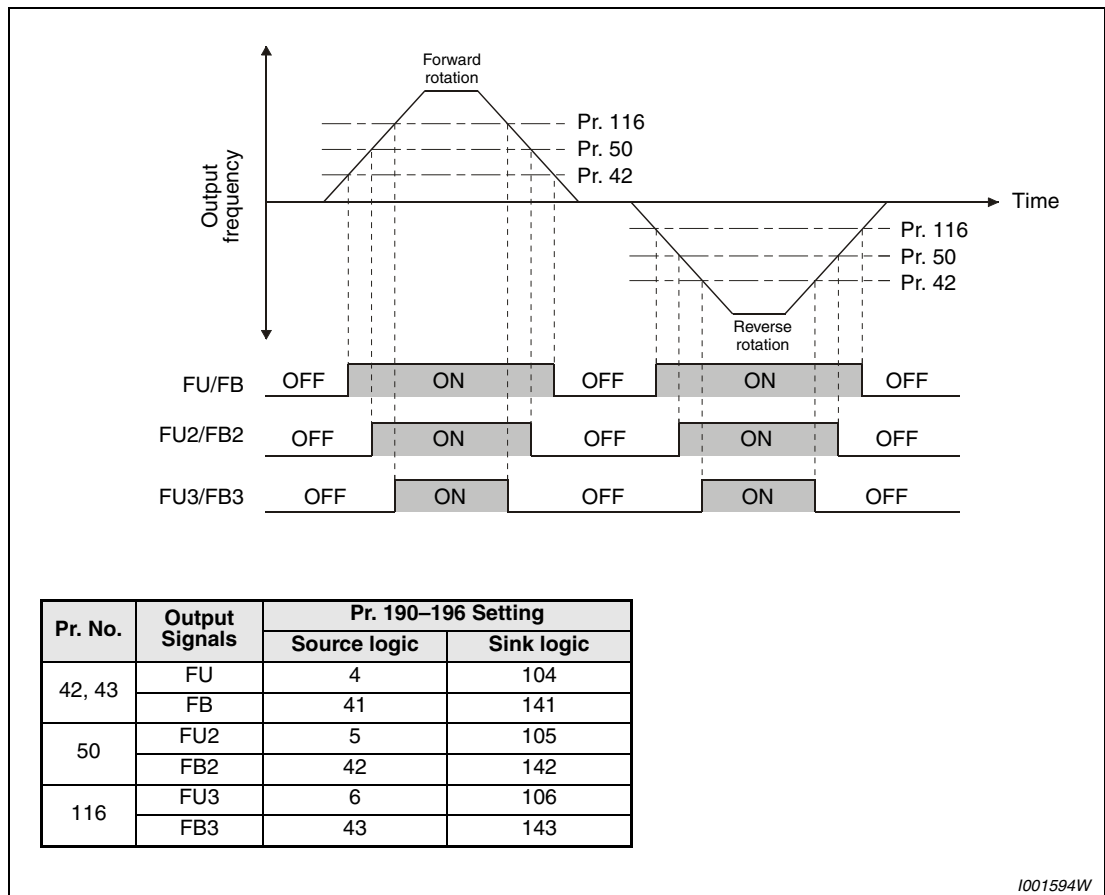

**Fig. 6-139: Frequency detection for forward and reverse rotation**

**Low speed detection (LS signal, Pr. 865)**

The low speed detection signal (LS) is output when the output frequency reduces below the Pr. 865 "Low speed detection setting".

When speed control is performed by real sensorless vector control or vector control, an alarm (E.OLT) is displayed and the inverter output is stopped if frequency drops to the Pr. 865 setting by torque limit operation and the output torque exceeds Pr. 874 OLT level setting and remains for more than 3s.

For the LS signal, set "34 (source logic) or 134 (sink logic)" in Pr. 190 to Pr. 196 (output terminal function selection) and assign functions to the output terminal.

**NOTES**

The FU signal is assigned to the terminal FU and the SU signal is assigned to the terminal SU in the initial setting.

All signals are OFF during DC injection brake, pre-excitation (zero speed control, servo lock), or start time tuning.

The output frequency to be compared with the set frequency at the SU signal and LS signal differs according to the control method.

Control Method	Compared Output Frequency
V/f control	Output frequency
Advanced magnetic flux vector control	Output frequency before slip compensation
Real sensorless vector control	Frequency (actual motor speed) estimated value
Encoder feedback control, vector control	Value of actual motor rotation represented in terms of frequency setting

When terminal assignment is changed using Pr. 190 to Pr. 196 (output terminal function selection), the other functions may be affected. Please make setting after confirming the function of each terminal

### 6.14.7 Output current detection function (Y12, Y13, Pr. 150 to Pr. 153, Pr. 166, Pr. 167)

The output power during inverter running can be detected and output to the output terminal.

Pr. No.	Name	Initial Value	Setting Range	Description	Parameters referred to	Refer to Section
150	Output current detection level	150% ①	0-220% ①	Set the output current detection level. 100% is the rated inverter current.	190-196	6.12.3 6.12.4 6.14.5
				Set the output current detection period. Set the time from when the output current has risen above the setting until the output current detection signal (Y12) is output.		
151	Output current detection signal delay time	0s	0-10s	Set the zero current detection level. The rated inverter current is assumed to be 100%.		
152	Zero current detection level	5%	0-250%	Set this parameter to define the period from when the output current drops below the Pr. 152 value until the zero current detection signal (Y13) is output.		
153	Zero current detection time	0.5s	0-1s	Set the retention time when the Y12 signal is on.		
166	Output current detection signal retention time	0.1s	0-10s	The Y12 signal on status is retained. The signal is turned off at the next start.		
			9999			
167	Output current detection operation selection	0	0	Operation continues when the Y12 signal is on.		
			1	The inverter is brought to an alarm stop when the Y12 signal is on. (E.CDO)		

① When Pr. 570 Multiple rating setting ≠ "2", performing all parameter clear and inverter reset changes the initial value and setting range. (Refer to section 6.7.5.)

#### Output current detection (Y12, Pr. 150, Pr. 151, Pr. 166, Pr. 167)

The output power detection function can be used for excessive torque detection, etc.

If the output current remains higher than the Pr. 150 setting during inverter operation for longer than the time set in Pr. 151, the output current detection signal (Y12) is output from the inverter's open collector or relay output terminal.

When the Y12 signal turns on, the ON state is held for the time set in Pr. 166 . When Pr. 166 = 9999, the ON state is held until a next start.

At the Pr. 167 setting of "1", the inverter output is stopped and the output current detection alarm (E.CDO) is displayed when the Y12 signal turns on. When an alarm stop occurs, the Y12 signal is on for the time set in Pr. 166 at the Pr. 166 setting of other than "9999", and remains on until a reset is made at the Pr. 166 setting of "9999".

Set "12 (source logic)" or "112 (sink logic)" to any of Pr.190 to Pr. 196 "Output terminal function selection" to assign the function of the Y12 signal to the output terminal.

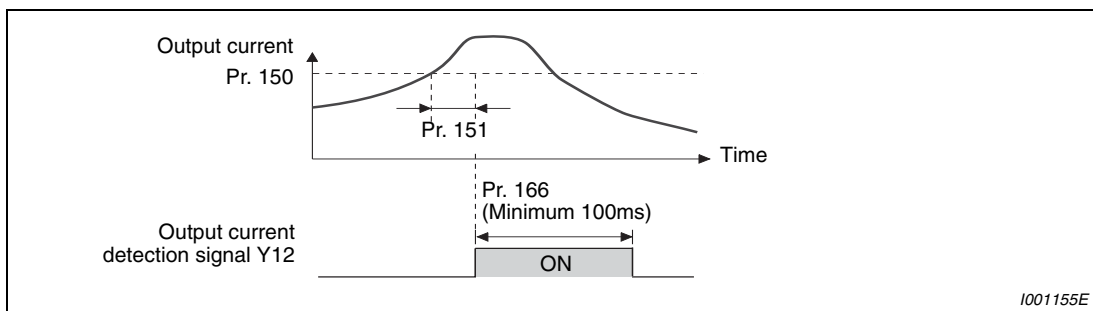

Fig. 6-140: Output current detection (Pr. 166 ≠ 9999, Pr. 167 = 0)

### Zero current detection (Y13, Pr. 152, Pr. 153)

If the output current remains lower than the Pr. 152 setting during inverter operation for longer than the time set in Pr. 153, the zero current detection (Y13) signal is output from the inverter's open collector or relay output terminal. As soon as the signal is output to terminal Y13, it remains turned on for 100ms.

When the inverter's output current falls to "0", torque will not be generated. This may cause a drop due to gravity when the inverter is used in vertical lift application. To prevent this, the output current zero signal (Y13) can be output from the inverter to close the mechanical brake when the output current has fallen to "zero".

Set "13" (source logic) or "113" (sink logic) to any of Pr. 190 to Pr. 196 "Output terminal function selection" to assign the function of the output power detection signal (Y13) to the output terminal.

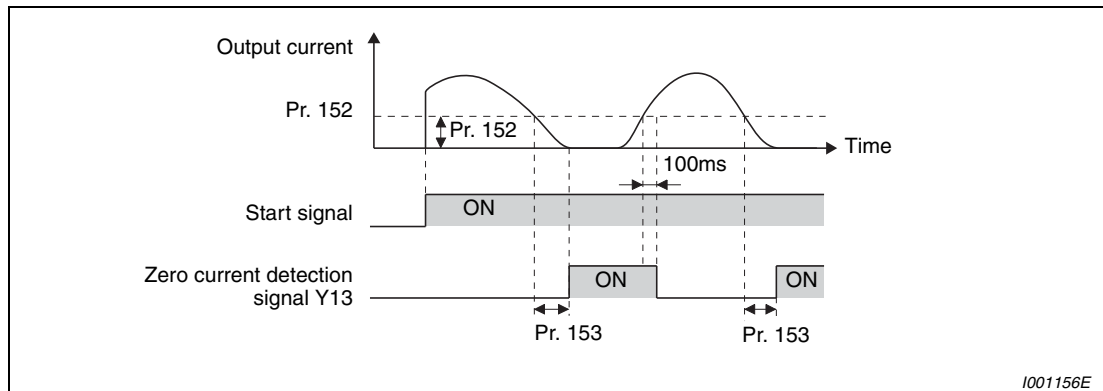

**Fig. 6-141:** Zero current detection

#### NOTES

This function is also valid during execution of the online or offline auto tuning.

The response time of Y12 and Y13 signals is approximately 350ms.

When terminal assignment is changed using Pr. 190 to Pr. 196 "Output terminal function selection", the other functions may be affected. Please make setting after confirming the function of each terminal.



#### CAUTION:

**The zero current detection level setting should not be too high, and the zero current detection time setting not too long. Otherwise, the detection signal may not be output when torque is not generated at a low output current.**

**To prevent the machine and equipment from resulting in hazardous conditions by use of the zero current detection signal, install a safety backup such as an emergency brake.**

**6.14.8 Detection of output torque (TU signal, Pr. 864)** Sensorless Magnetic flux Vector

Output the signal when the motor torque rises above the setting value. This function can be used for electromagnetic brake operation, open signal, etc.

Pr. No.	Name	Initial Value	Setting Range	Description	Parameters referred to	Refer to Section
<b>864</b>	Torque detection	150%	0-400%	Set the torque value where the TU signal turns on.	190-196 Output terminal function selection	6.14.5

When the output torque reaches or exceeds the detected torque value set in Pr. 864 under real sensorless vector control, advanced magnetic flux vector control or vector control, the torque detection signal (TU) turns on. It turns off when the torque falls below the detection torque value.

For the TU signal, set "35 (source logic) or 135 (sink logic)" in Pr. 190 to Pr. 196 (output terminal function selection) and assign functions to the output terminal.

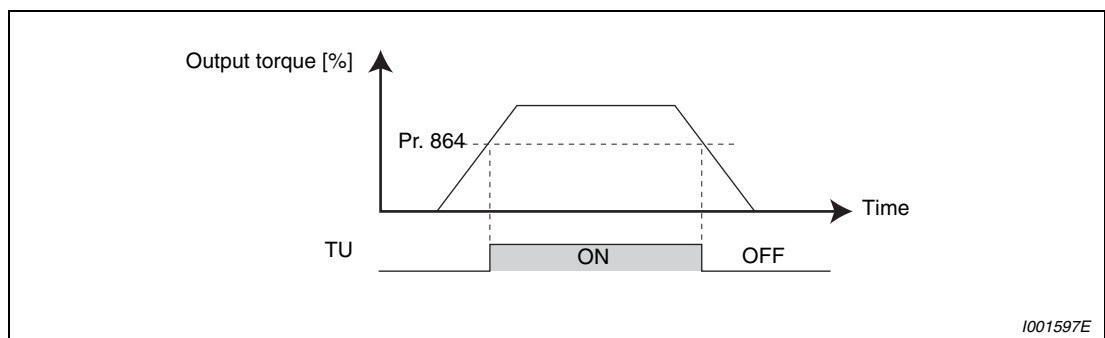

**Fig. 6-142: Torque detection**

**NOTE**

When terminal assignment is changed using Pr. 190 to Pr. 196 "Output terminal function selection", the other functions may be affected. Please make setting after confirming the function of each terminal.

## 6.14.9 Remote output function (REM, Pr. 495 to Pr. 497)

You can utilize the on/off of the inverter's output signals instead of the remote output terminal of the programmable logic controller.

Pr. No.	Name	Initial Value	Setting Range	Description	Parameters referred to	Refer to Section
<b>495</b>	Remote output selection	0	0	Remote output data clear at powering off	190–196 Output terminal function selection	6.14.5
			1	Remote output data retention even at powering off		
			10	Remote output data clear at powering off		
			11	Remote output data retention even at powering off		
<b>496</b>	Remote output data 1 ①	0	0–4095	Refer to Fig. 6-143		
<b>497</b>	Remote output data 2 ①	0	0–4095			

① The above parameters allow its setting to be changed during operation in any operation mode even if "0" (initial value) is set in Pr. 77 "Parameter write selection".

The output terminal can be turned on/off depending on the Pr. 496 or Pr. 497 setting. The remote output selection can be controlled on/off by computer link communication from the PU connector or RS-485 port or by communication from the communication option.

Set "96" (source logic) or "196" (sink logic) to any of Pr. 190 to Pr. 196 "Output terminal function selection", and assign the remote output (REM) signal to the terminal used for remote output.

When you refer to Fig. 6-143 and set "1" to the terminal bit (terminal where the REM signal has been assigned) of Pr. 496 or Pr. 497, the output terminal turns on (off for sink logic). By setting "0", the output terminal turns off (on for sink logic).

**Example** ▾

When "96" (source logic) is set to Pr. 190 "RUN terminal function selection" and "1" (H01) is set to Pr. 496, the terminal RUN turns on.

△

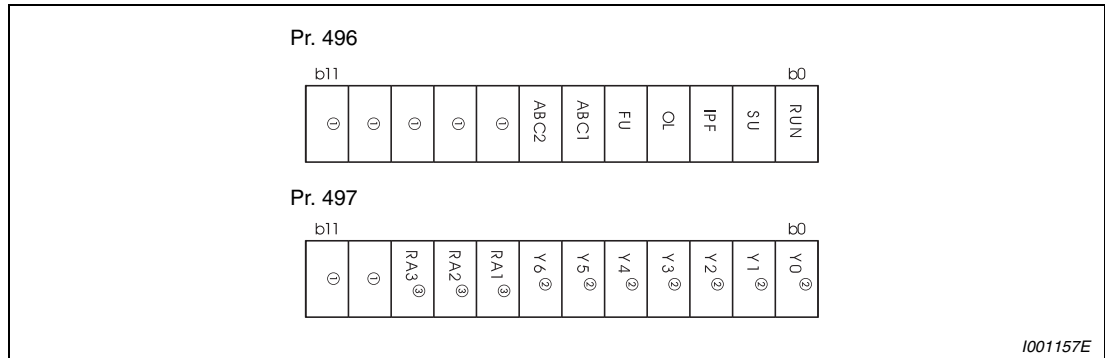

**Fig. 6-143:** Remote output data

- ① As desired (always "0" when read).
- ② Y0 to Y6 are available only when the extension output option (FR-A7AY) is fitted.
- ③ RA1 to RA3 are available only when the relay output option (FR-A7AR) is fitted.

When Pr. 495 = 0 (initial value) or 10, performing a power supply reset (including a power failure) clears the REM signal output. (The ON/OFF status of the terminals are as set in Pr. 190 to Pr. 196.) The Pr. 496 and Pr. 497 settings are also "0".

When Pr. 495 = 1 or 11, the remote output data before power supply-off is stored into the EEPROM, so the signal output at power recovery is the same as before power supply-off. However, it is not stored when the inverter is reset (terminal reset, reset request through communication). (See the chart below.)

When Pr. 495 = "10, 11", the signal before reset is held even an inverter reset is made.

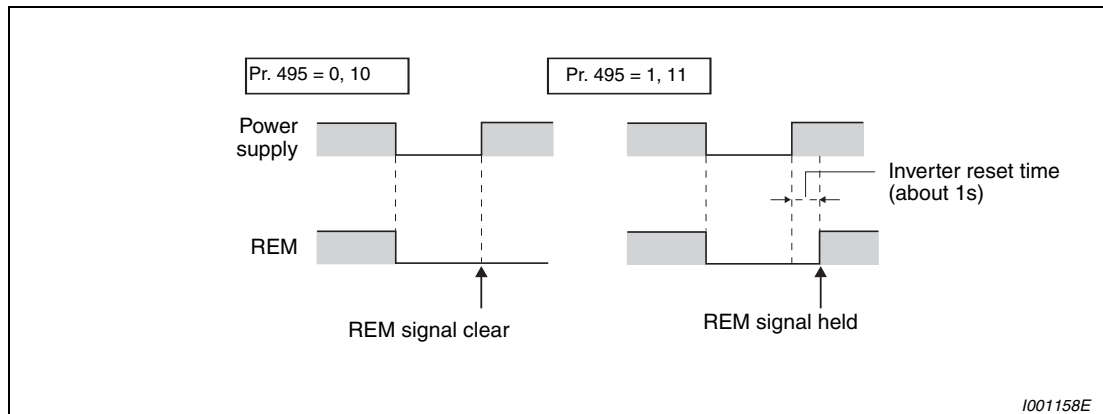

**Fig. 6-144:** ON/OFF example for source logic

#### NOTES

The output terminal where the REM signal is not assigned using any of Pr. 190 to Pr. 196 does not turn on/off if "0/1" is set to the terminal bit of Pr. 496 or Pr. 497. (It turns on/off with the assigned function.)

When the inverter is reset (terminal reset, reset request through communication), Pr. 496 and Pr. 497 values turn to "0". When Pr. 495 = "1, 11", however, they are the settings at power supply-off. (The settings are stored at power supply-off.) When Pr. 495 = "10, 11", they are the same as before an inverter reset is made.

When Pr. 495 = 1, take such a step as to connect R1/L11, S1/L21 and P/+, N/- to ensure that control power will be retained to some degree. If you do not take such a step, the output signals provided after power-on are not guaranteed.



## 6.15 Monitor display and monitor output signals

Purpose	Parameters that must be set		Refer to Section
Display motor speed Set speed	Speed display and speed setting	Pr. 37, Pr. 144, Pr. 505, Pr. 811	6.15.1
Change PU monitor display data	DU/PU main display data selection Cumulative monitor clear	Pr. 52, Pr. 170, Pr. 171, Pr. 268, Pr. 891	6.15.2
Change of the monitor output from terminal CA and AM	Terminal CA, AM function selection	Pr. 54, Pr. 158, Pr. 291, Pr. 866, Pr. 867, Pr. 869	6.15.3
Set the reference of the monitor output from terminal CA and AM	Setting of reference of terminal CA and AM	Pr. 55, Pr. 56, Pr. 291, Pr. 866, Pr. 867	6.15.3
Adjust terminal CA, AM outputs	Terminal CA, AM calibration	Pr. 900, Pr. 901, Pr. 930, Pr. 931	6.15.4

### 6.15.1 Speed display and speed setting (Pr. 37, Pr. 144)

You can change the PU (FR-DU07/FR-PU04/FR-PU07) monitor display or frequency setting to motor speed or machine speed.

Pr. No.	Name	Initial Setting	Setting Range	Description	Parameters referred to	Refer to Section	
<b>37</b>	Speed display	0	0	Frequency display, setting	52 DU/PU main display data selection	6.15.2	
			1-9998	Set the machine speed at Pr. 505.			
<b>144</b>	Speed setting switchover	4	0/2/4/6/8/ 10/102/ 104/106/ 108/110	Set the number of motor poles when displaying the motor speed.	80 Motor capacity 81 Number of motor poles	6.7.2 6.7.2	
<b>505</b>	Speed setting reference	50Hz	0-120Hz	Set the reference speed for Pr. 37.	800 Control system selection	6.2.2	
<b>811</b>	Set resolution switchover	0		Speed setting and running speed monitor increments from the PU, RS-485 communication or communication option.	Torque limit setting increments Pr. 22, Pr. 812 to Pr. 817	811 Set resolution switchover	6.3.2
			0	1 r/min	0.1%		
			1	0.1 r/min			
			10	1 r/min	0.01%		
11	0.1 r/min						

To display the machine speed, set in Pr. 37 the machine speed for operation with frequency set in Pr. 505. For example, when Pr. 505 = "60Hz" and Pr. 37 = "1000", "1000" is displayed on the running speed monitor when the running frequency is 60Hz. When running frequency is 30Hz, "500" is displayed.

When displaying the motor speed, set the number of motor poles (2, 4, 6, 8, 10) or number of motor poles + 100 (102, 104, 106, 108, 110) in Pr. 144.

The Pr. 144 setting is automatically changed if the number of motor poles is set in Pr.81 Number of motor poles. The Pr. 81 setting is not automatically changed even if the setting of Pr. 144 is changed.

- Example 1: When the initial setting of Pr. 81 is changed to "2" or "12", the Pr. 144 setting changes from "4" to "2".
- Example 2: When Pr. 144 = "104", setting "2" in Pr. 81 changes the Pr. 144 setting from "104" to "102".

When "1, or 11" is set in Pr. 811, the setting increments of speed setting from the PU, speed setting from RS-485 communication or communication options (other than FR-A7ND, FR-A7NL, FR-A7NCA) and running speed monitor is 0.1r/min.

When both Pr. 37 and Pr. 144 have been set, their priorities are as given below.

Pr. 144, 102 to 110 > Pr. 37, 1 to 9998 > Pr. 144, 2 to 10

When the running speed monitor is selected, each monitor and setting are determined by the combination of Pr.37 and Pr. 144 as listed below. (The units within the grayed line shown in Tab. 6-92 are the initial values.)

Pr. 37	Pr. 144	Output Frequency Monitor	Set Frequency Monitor	Running Speed Monitor	Frequency Setting Parameter Setting
0 (initial value)	0	Hz	Hz	r/min <sup>①</sup>	Hz
	2-10	Hz	Hz	r/min <sup>①</sup>	Hz
	102-110	r/min <sup>①</sup>	r/min <sup>①</sup>	r/min <sup>①</sup>	r/min <sup>①</sup>
1-9998	0	Hz	Hz	Machine speed <sup>①</sup>	Hz
	2-10	Machine speed <sup>①</sup>	Machine speed <sup>①</sup>	Machine speed <sup>①</sup>	Machine speed <sup>①</sup>
	102-110	Hz	Hz	r/min <sup>①</sup>	Hz

**Tab. 6-92: Setting range of parameter 37 and 144**

- ① Motor speed (r/min) conversion formula: frequency × 120/number of motor poles (Pr. 144)  
Machine speed conversion formula: Pr. 37 × frequency/Pr. 505Hz  
For Pr. 144 in the above formula, the value is "Pr. 144 – 100" when "102 to 110" is set in Pr. 144 and the value is "4" when Pr. 37 = 0 and Pr. 144 = 0.
- ② Hz is in 0.01Hz increments, machine speed is in 1m/min increments, and r/min is in 1r/min increments.
- ③ Pr. 505 is always set as frequency (Hz).

**NOTES**

In the V/f control mode, the output frequency of the inverter is displayed in terms of synchronous speed, and therefore, it is unequal to the actual speed by motor slip. This display changes to the actual speed (estimated value calculated based on the motor slip) when the advanced magnetic flux vector control or real sensorless vector control is selected, and actual speed from the encoder when encoder feed back control or vector control is performed.

When the running speed display is selected at the setting of Pr. 37 = 0 and Pr. 144 = 0, the monitor display is provided on the assumption that the number of motor poles is 4. (1800r/min is displayed at 60Hz.)

Refer to Pr. 52 when you want to change the PU main monitor (PU main display).

Since the panel display of the operation panel (FR-DU07) is 4 digits in length, the monitor value of more than "9999" is displayed "----".

After setting the running speed in 0.1r/min increments (Pr. 811 = "1, 11"), changing the setting increments to 1r/min increments (Pr. 811 = "0, 10") changes the speed resolution from 0.1r/min to 0.3r/min (four poles), which may round down 0.1r/min increments.

When the machine speed is displayed on the FR-PU04/FR-PU07, do not change the speed by using an up/down key in the state where the set speed exceeding 65535 is displayed. The set speed may become arbitrary value.

When an optional FR-A7ND, FR-A7NL or FR-A7NCA is mounted, frequency is displayed (setting) regardless of Pr. 37 and Pr. 144.

**CAUTION:**

***Make sure that the settings of the running speed and number of motor poles are correct. Otherwise, the motor might run at extremely high speed, damaging the machine.***

## 6.15.2 DU/PU monitor display selection (Pr. 52, Pr. 54, Pr. 158, Pr. 170, Pr. 171, Pr. 268, Pr. 563, Pr. 564, Pr. 891)

The monitor to be displayed on the main screen of the operation panel (FR-DU07)/parameter unit (FR-PU04/FR-PU07) can be selected.

In addition, signals to be output from the terminal CA (analog current output) and AM (analog voltage output) can be selected.

Pr. No.	Name	Initial Value	Setting Range	Description	Parameters referred to	Refer to Section
52	DU/PU main display data selection ①	0 (output frequency)	0/5-14/ 17-20/ 22-25/ 32-35/46 50-57/100	Select the monitor to be displayed on the operation panel and parameter unit. Refer to Tab. 6-93 for monitor description.	37 Speed display 144 Speed setting switchover	6.15.1 6.15.1
			54 CA terminal function selection ①	1 (output frequency)	1-3/5-14/ 17/18/21/ 24/32-34/ 46/50/52/ 53/70	Select the monitor output to terminal CA.
158	AM terminal function selection ①			Select the monitor output to terminal AM.	866 Torque monitoring reference 291 Pulse train I/O selection	6.15.3 6.15.4
170	Watt-hour meter clear	9999	0	Set "0" to clear the watt-hour meter monitor.		
			10	Set the maximum value when monitoring from communication to 0 to 9999kWh.		
			9999	Set the maximum value when monitoring from communication to 0 to 65535kWh.		
171	Operation hour meter clear	9999	0/9999	Set "0" in the parameter to clear the watt-hour monitor. Setting "9999" has no effect.		
268	Monitor decimal digits selection ①	9999	0	Displays as integral value.		
			1	Displayed in 0.1 increments.		
			9999	No function		
563	Energizing time carrying-over times	0	0-65535 (reading only)	The numbers of cumulative energizing time monitor exceeded 65535h is displayed. Reading only		
564	Operating time carrying-over times	0	0-65535 (reading only)	The numbers of operation time monitor exceeded 65535h is displayed. Reading only		
891	Cumulative power monitor digit shifted times	9999	0-4	Set the number of times to shift the cumulative power monitor digit. Clamp the monitoring value at maximum.		
			9999	No shift The monitor value is cleared when it exceeds the maximum value.		

① The above parameters allow its setting to be changed during operation in any operation mode even if "0" (initial value) is set in Pr. 77 "Parameter write selection".

**Monitor description list (Pr. 52)**

- Set the monitor to be displayed on the operation panel (FR-DU07) and parameter unit (FR-PU04/FR-PU07) in Pr. 52 "DU/PUmain display data selection".
- Set the monitor to be output to the terminal CA ((analog current output) in Pr. 54 "CA terminal function selection".
- Set the monitor to be output to the terminal AM (analog voltage output (0 to 10VDC voltage output)) in Pr. 158 "AM terminal function selection".

Types of Monitor	Increments	Pr. 52		Pr. 54 (CA) Pr. 158 (AM) Setting	Full-scale value of the terminal CA and AM	Description
		DU LED	PU Main Monitor			
Output frequency	0.01Hz	0/100		1	Pr. 55	Displays the inverter output frequency.
Output current	0.01A/0.1A ②	0/100		2	Pr. 56	Displays the inverter output current effective value.
Output voltage	0.1V	0/100		3	800V	Displays the inverter output voltage.
Alarm display	—	0/100		—	—	Displays 8 past alarms individually.
Frequency setting	0.01Hz	5	①	5	Pr. 55	Displays the set frequency.
Running speed	1r/min	6	①	6	The value converted with the Pr. 37 value from Pr. 55	Displays the motor speed. (depending on Pr. 37 and Pr. 144 settings, refer to page 6-321)
Motor torque	0.1%	7	①	7	Pr. 866	Display the motor torque in percentage on the assumption that the rated motor torque is 100% (0% is displayed during V/f control)
Converter output voltage	0.1V	8	①	8	800V	Displays the DC bus voltage value.
Regenerative brake duty	0.1%	9	①	9	Pr. 70	Brake duty set in Pr. 30 and Pr. 70.
Electronic thermal relay function load factor	0.1%	10	①	10	100%	Displays the motor thermal cumulative value on the assumption that the thermal operation level is 100%.
Output current peak value	0.01A/0.1A ②	11	①	11	Pr. 56	Retain the peak value of the output current monitor and display (cleared at every start).
Converter output voltage peak value	0.1V	12	①	12	800V	Retain the peak value of the DC bus voltage value (cleared at every start).
Input power	0.01kW/0.1kW ②	13	①	13	Rated inverter power × 2	Display power of the inverter input side
Output power	0.01kW/0.1kW ②	14	①	14	Rated inverter power × 2	Display power of the inverter output side
Load meter	0.1%	17		17	100%	Torque current is displayed in % on the assumption that the Pr. 866 setting is 100%
Motor excitation current	0.01A/0.1A ②	18		18	Pr. 56	Display the excitation current of the motor
Position pulse ②	—	19		—	—	Display the number of pulses per rotation of the motor when orientation control is valid

**Tab. 6-93:** Monitor description list (1)

Types of Monitor	Increments	Pr. 52		Pr. 54 (CA) Pr. 158 (AM) Setting	Full-scale value of the terminal CA and AM	Description
		DU LED	PU Main Monitor			
Cumulative energizing time ②	1h	20	—	—	—	Cumulative energization time since the inverter shipment is displayed. You can check the numbers of the monitor value exceeded 65535h with Pr. 563.
Reference voltage output	—	—	21	—	—	Terminal CA: 20mA is output Terminal AM: 10V is output
Orientation status (FR-A7AP option) ②	1	22	—	—	—	Display only when orientation control is valid (Refer to section 6.13.6)
Actual operation time ④ ⑤ ⑥	1h	23	—	—	—	Cumulative inverter running time is displayed. You can check the numbers of the monitor value exceeded 65535h with Pr. 564. Use Pr. 171 to clear the value. (Refer to page 6-331.)
Motor load factor	0.1%	24	24	200%	—	On the assumption that the rated inverter current value is 100%, the output current value is displayed in %. Monitor value = Ioutput current monitor value / rated inverter current × 100 [%]
Cumulative power ⑧	0.01kWh/ 0.1kWh ④ ⑤	25	—	—	—	Cumulative power amount is displayed according to the output power monitor Use Pr. 170 to clear the value. (Refer to page 6-331.)
Torque command	0.1%	32	32	Pr. 866	—	Display torque command value obtained from vector control
Torque current command	0.1%	33	33			Display torque current command value
Motor output	0.01kW/ 0.1kW ⑦	34	34	Rated motor capacity	—	Multiply the motor speed by the then output torque and display the machine output of the motor shaft end
Feedback pulse ③ ⑧	—	35	—	—	—	Display the number of pulses fed back from the encoder during one sampling (display during a stop).
Motor temperature	1°C	46	46	Pr. 751	—	Display of the motor temperature is available when a inverter manufactured in December 2010 or later is used in combination with a dedicated motor with thermistor and the option FR-A7AZ.
Power saving effect	Variable according to parameters	50	50	Inverter capacity	—	Display energy saving effect monitor You can change the monitor to power saving, power saving average value, charge display and % display using parameters. (Refer to page 6-364 for details.)
Cumulative saving power		51	—	—		
PID set point	0.1%	52	52	100%	—	Display the set point, measured value and deviation during PID control. (Refer to page 6-491 for details.)
PID measured value	0.1%	53	53	100%		
PID deviation value	0.1%	54	—	—		

Tab. 6-93: Monitor description list (2)

Types of Monitor	Increments	Pr. 52		Pr. 54 (CA) Pr. 158 (AM) Setting	Full-scale value of the terminal CA and AM	Description
		DU LED	PU Main Monitor			
Input terminal status	—	55	①	—	—	ON/OFF status of the input terminal is displayed on the PU (Refer to page 6-330 for DU display)
Output terminal status	—		①	—	—	ON/OFF status of the output terminal is displayed on the PU (Refer to page 6-330 for DU display)
Option input terminal states	—	56	—	—	—	ON/OFF status of the input terminal of the digital input option (FR-A7AX) is displayed on the DU (Refer to page 6-330 for DU display)
Option output terminal states	—	57	—	—	—	ON/OFF status of the output terminal of the digital output option (FR-A7AY) and relay output option (FR-A7AR) is displayed on the DU (Refer to page 6-330 for DU display)
PLC function output	0.1%	—	—	70	100%	Desired values can be output from terminal CA and AM using the PLC function. Refer to the FR-A700 PLC function programming manual for details of the PLC function.

**Tab. 6-93:** Monitor description list (3)

- ① Frequency setting to output terminal status on the PU main monitor are selected by "other monitor selection" of the parameter unit (FR-PU04/FR-PU07).
- ② Position pulse and orientation status function when used with an option (FR-A7AP). When orientation control is invalid, "0" remains displayed and these functions are invalid.
- ③ Feedback pulse functions when the option (FR-A7AP) is used and vector control is performed.
- ④ The cumulative energizing time and actual operation time are accumulated from 0 to 65535 hours, then cleared, and accumulated again from 0. When the operation panel (FR-DU07) is used, the time is displayed up to 65.53 (65530h) on the assumption that 1h = 0.001, and thereafter, it is added up from 0.
- ⑤ The actual operation time is not added up if the cumulative operation time before power supply-off is less than 1h.
- ⑥ When using the parameter unit (FR-PU04/FR-PU07), "kW" is displayed.
- ⑦ The setting depends on capacities. (01800 or less/02160 or more)
- ⑧ Since the panel display of the operation panel (FR-DU07) is 4 digits in length, the monitor value of more than "9999" is displayed "----".

**NOTES**

By setting "0" in Pr. 52, the monitoring of output frequency to alarm display can be selected in sequence by the SET key.

When the operation panel (FR-DU07) is used, the displayed units are Hz, V and A only and the others are not displayed.

The monitor set in Pr. 52 is displayed in the third monitor position. (The output voltage monitor is changed.)

The monitor displayed at powering on is the first monitor. Display the monitor to be displayed on the first monitor and press the SET key for 1s. (To return to the output frequency monitor, hold down the SET key for 1s after displaying the output frequency monitor.)

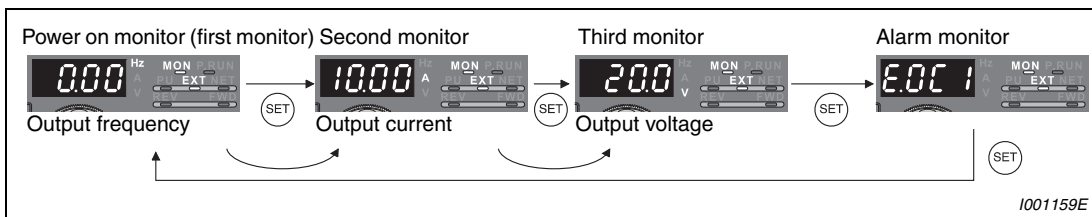

**Fig. 6-145:** Displaying various types of monitor

**Example** ▽

When Pr. 52 is set to "20" (cumulative energizing time), the monitor is displayed on the operation panel as described below.

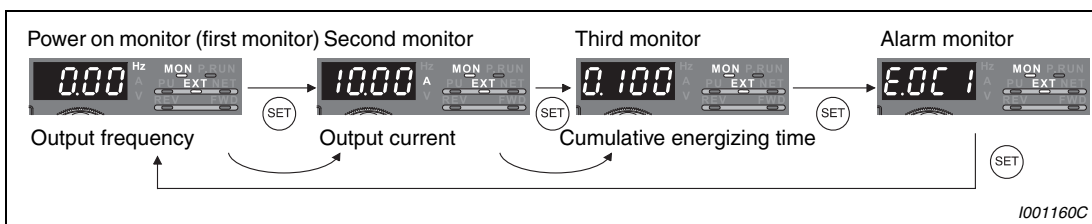

**Fig. 6-146:** Selection of the third monitor





**Display set frequency during stop (Pr. 52)**

When Pr. 52 is set to "100", the set frequency monitor is displayed during a stop and the output frequency monitor is displayed during operation. (Hz indication flickers during stop and is lit during running.)

	Parameter 52		
	0	100	
	During running/stop	During stop	During running
Output frequency	Output frequency	Set frequency	Output frequency
Output current	Output current		
Output voltage	Output voltage		
Alarm display	Alarm display		

**Tab. 6-94:** *Display during running and stop*

**NOTES**

- | During an error, the output frequency at error occurrence appears.
- | During MRS, the values displayed are the same as during a stop.
- | During offline auto tuning, the tuning status monitor has priority.

**Operation panel (FR-DU07) I/O terminal monitor**

When Pr. 52 is set to any of "55 to 57", the I/O terminal states can be monitored on the operation panel (FR-DU07).

The I/O terminal monitor is displayed on the third monitor.

The LED is on when the terminal is on, and the LED is off when the terminal is off. The centre line of LED is always on.

Pr. 52	Monitor Description
55	Displays the I/O and output terminal ON/OFF states of the inverter unit.
56 ①	Displays the input terminal ON/OFF states of the digital input option (FR-A7AX).
57 ①	Displays the output terminal ON/OFF states of the digital output option (FR-A7AY) or relay output option (FR-A7AR).

**Tab. 6-95: I/O terminal monitor**

① You can set "56" or "57" even if the option is not fitted. When the option is not fitted, the monitor displays are all off.

On the unit I/O terminal monitor (Pr. 52 = 55), the upper LEDs denote the input terminal states and the lower the output terminal states.

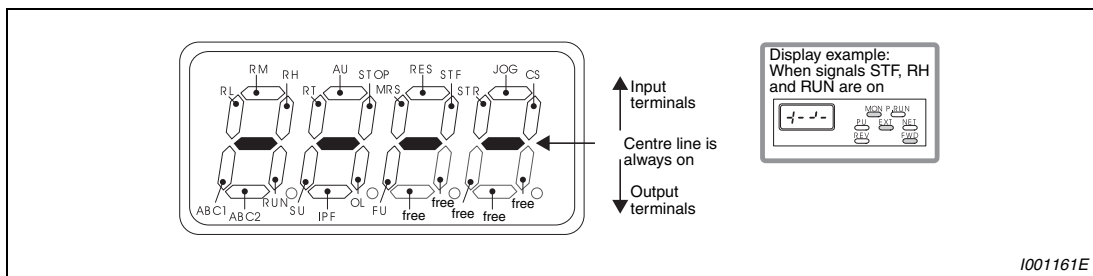

**Fig. 6-147: Displaying the signal states of the I/O terminals**

On the option FR-A7AX monitor (Pr. 52 = 56), the decimal point LED of the first digit LED is on.

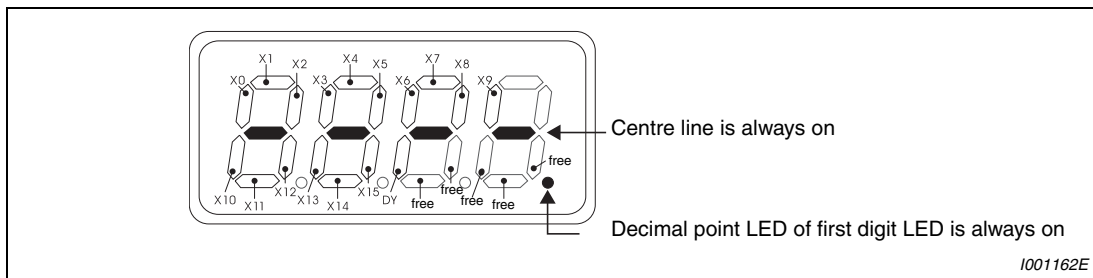

**Fig. 6-148: Displaying the signal states when the option FR-A7AX is mounted**

On the option FR-A7AY or FR-A7AR monitor (Pr. 52 = 57), the decimal point LED of the second digit LED is on.

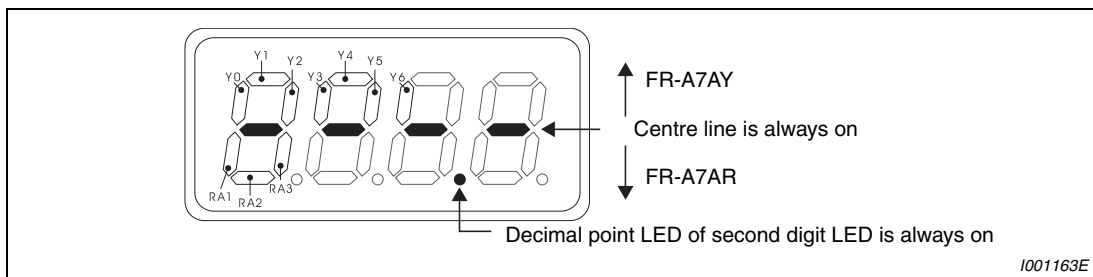

**Fig. 6-149: Displaying the signal states when the option FR-A7AY or FR-A7AR is mounted**

**Cumulative energizing power monitor and clear (Pr. 170, Pr. 891)**

On the cumulative energizing power monitor (Pr. 52 = 25), the output power monitor value is added up and is updated in 1h increments. The operation panel (FR-DU07), parameter unit (FR-PU04/FR-PU07) and communication (RS-485 communication, communication option) display units and display ranges are as indicated below:

FR-DU07 ①		FR-PU04/FR-PU07 ②		Communication		
Range	Unit	Range	Unit	Range		Unit
				Pr. 170 = 10	Pr. 170 = 9999	
0–99.99kWh	0.01kWh	0–999.99kWh	0.01kWh	0–9999kWh	0–65535kWh (initial value)	1kWh
100–9.999kWh	0.1kWh	1000–9999.9kWh	0.1kWh			
1000–9999kWh	1kWh	1000–99999kWh	1kWh			

**Tab. 6-96:** Units and range of the cumulative energizing monitor

- ① Power is measured in the range 0 to 9999.99kWh, and displayed in 4 digits. When the monitor value exceeds "99.99", a carry occurs, e.g. "100.0", so the value is displayed in 0.1kWh increments.
- ② Power is measured in the range 0 to 99999.99kWh, and displayed in 5 digits. When the monitor value exceeds "999.99", a carry occurs, e.g. "1000.0", so the value is displayed in 0.1kWh increments.

The monitor data digit can be shifted to the right by the number set in Pr. 891. For example, if the cumulative power value is 1278.56kWh when Pr. 891 = 2, the PU/DU display is 12.78 (display in 100kWh increments) and the communication data is 12.

If the maximum value is exceeded at Pr. 891 = 0 to 4, the power is clamped at the maximum value, indicating that a digit shift is necessary. If the maximum value is exceeded at Pr. 891 = 9999, the power returns to 0 and is recounted.

Writing "0" to Pr. 170 clears the cumulative energizing power monitor.

**NOTE** | If "0" is written to Pr. 170 and Pr. 170 is read again, "9999" or "10" is displayed.

**Cumulative energizing time and actual operation time monitor (Pr. 171, Pr. 563, Pr. 564)**

On the cumulative energization time monitor (Pr. 52 = 20), the inverter running time is added up every hour.

On the actual operation time monitor (Pr. 52 = 23), the inverter running time is added up every hour. (Time is not added up during a stop.)

If the numbers of monitor value exceeds 65535, it is added up from 0. You can check the numbers of cumulative energizing time monitor exceeded 65535h with Pr. 563 and the numbers of actual operation time monitor exceeded 65535h with Pr. 564.

Writing "0" to Pr. 171 clears the actual operation time monitor. (Energizing time monitor can not be cleared.)

**NOTES** | The actual operation time is not added up unless the inverter is operated one or more hours continuously.  
| If "0" is written to Pr. 171 and Pr. 171 is read again, "9999" is always displayed. Setting "9999" does not clear the actual operation time meter.

**You can select the decimal digits of the monitor (Pr. 268)**

As the operation panel (FR-DU07) display is 4 digits long, the decimal places may vary at analog input, etc. The decimal places can be hidden by selecting the decimal digits. In such a case, the decimal digits can be selected by Pr. 268.

Pr. 268	Description
9999 (initial value)	No function
0	When 1 or 2 decimal places (0.1 increments or 0.01 increments) are monitored, the decimal places are dropped and the monitor displays an integer value (1 increments). The monitor value of 0.99 or less is displayed as 0.
1	When 2 decimal places (0.01 increments) are monitored, the 0.01 decimal place is dropped and the monitor displays the first decimal place (0.1 increments). When the monitor display digit is originally in 1 increments, it is displayed unchanged in 1 increments.

**Tab. 6-97:** Selection of decimal digits

**NOTE**

The number of display digits on the cumulative energizing time (Pr. 52 = 20), actual operation time (Pr. 52 = 23), cumulative energizing power (Pr. 52 = 25) or cumulative saving power monitor (Pr. 52 = 51) does not change.

### 6.15.3 CA, AM terminal function selection (Pr. 55, Pr. 56, Pr. 867, Pr. 869)

For signal output, two different output terminals are available: analog current output terminal CA and analog voltage output terminal AM. Set the reference of the signal output from terminal CA and AM.

Pr. No.	Name	Initial Value	Setting Range	Description	Parameters referred to	Refer to Section
<b>55</b>	Frequency monitoring reference ①	50Hz	0-400Hz	Set the full-scale value to output the output frequency monitor value to terminal CA and AM.	—	
<b>56</b>	Current monitoring reference ①	Rated inverter output current	01800 or less	0-500A	Set the full-scale value to output the output current monitor value to terminal CA and AM.	
			02160 or more	0-3600A		
<b>866</b>	Torque monitoring reference ①	150%	0-400%	Set the full-scale value to output the torque monitor value to terminal CA and AM.		
<b>867</b>	AM output filter	0.01s	0-5s	Set the output filter of terminal AM.		
<b>869</b>	Current output filter	0.02s	0-5s	Adjust response level of current output.		

① The above parameters allow its setting to be changed during operation in any operation mode even if "0" (initial value) is set in Pr. 77 "Parameter write selection".

#### Frequency monitoring reference (Pr. 55)

Set the frequency to be referenced when the frequency monitor (output frequency/set frequency) is selected for the terminal CA and terminal AM display.

- Set the frequency when the current output at terminal CA is 20mA DC. The analog current output at terminal CA and the inverter output frequency are proportional. (The maximum output current is 20mA DC.)
- Set the frequency (output frequency/set frequency) when the voltage output at terminal AM is 10V DC. The analog voltage output at terminal AM and the frequency are proportional. (The maximum output voltage is 10V DC.)

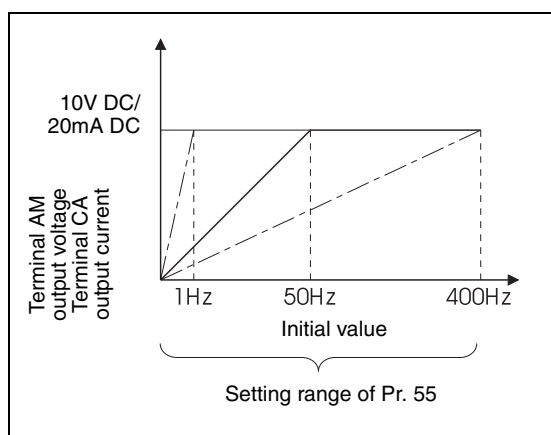

**Fig. 6-150:**  
Frequency monitoring reference

I001164E

**Current monitoring reference (Pr. 56)**

Set the current to be referenced when the current monitor (inverter output current, etc.) is selected for the terminal CA and terminal AM display.

- Set the current value when the current output at terminal CA is 20mA DC. The analog current output at terminal CA and the current value are proportional. (The maximum output current is 20mA DC.)
- Set the current value when the voltage output at terminal AM is 10V DC. The analog voltage output at terminal AM and the current value are proportional. (The maximum output voltage is 10V DC.)

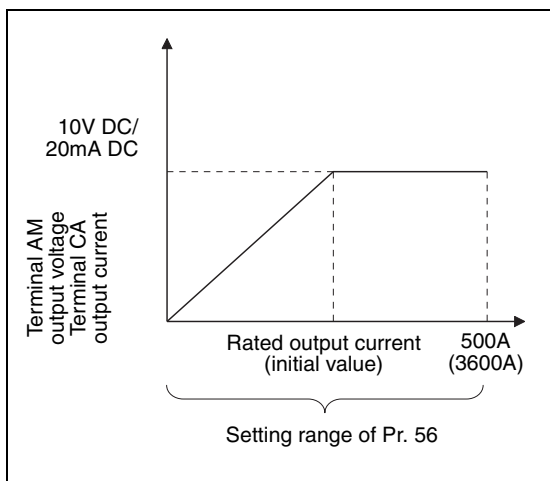

**Fig. 6-151:**  
Current monitoring reference

1001165E

**Torque monitoring reference (Pr. 866)**

Set the current to be referenced when the torque monitor is selected for the terminal CA and terminal AM display.

- Set the current value when the current output at terminal CA is 20mADC. The analog current output at terminal CA and the current value are proportional. (The maximum output current is 20mADC.)
- Set the current value when the voltage output at terminal AM is 10VDC. The analog voltage output at terminal AM and the current value are proportional. (The maximum output voltage is 10VDC.)

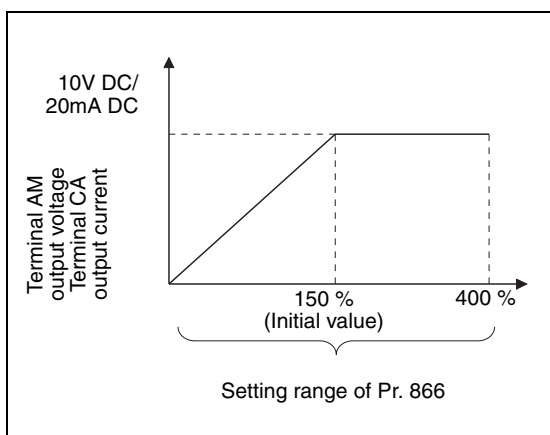

**Fig. 6-152:**  
Torque monitoring reference

1001598E

**Terminal AM response adjustment (Pr. 867)**

Using Pr. 867, the output voltage response of the terminal AM can be adjusted within the range 0 to 5s.

Increasing the setting stabilizes the terminal AM output more but reduces the response level. (Setting "0" sets the response level to 4ms.)

**Adjustment of response level of terminal CA (Pr. 869)**

The response level of the output current of the terminal CA can be adjusted between 0 and 5s with Pr. 869.

Increasing the setting stabilizes the terminal CA output more but reduces the response level. (Setting "0" sets the response level to about 7ms.)

### 6.15.4 Terminal CA, AM calibration [C0 (Pr. 900), C1 (Pr. 901), C8 (Pr. 930) to C11 (Pr. 931)]

These parameters are used to calibrate the CA and AM analog outputs for the minimum and maximum values, and you can also use them to compensate for the tolerances of your measuring instruments. The same monitor signal can be output to the AM and the CA terminals. However, zero point calibration and the entry of a value to be associated with the zero point for the monitor signal to be output are both only possible for the CA terminal.

Pr. No.	Name	Initial Value	Setting Range	Description
<b>C0 (900)</b>	CA terminal calibration	—	—	Calibrate the scale of the meter connected to terminal CA.
<b>C1 (901)</b>	AM terminal calibration	—	—	Calibrate the scale of the analog meter connected to terminal AM.
<b>C8 (930)</b>	Current output bias signal	0%	0–100%	Output signal value for minimum analog current output.
<b>C9 (930)</b>	Current output bias current	0%	0–100%	Output current value for minimum analog current output (e.g. 0 or 4mA)
<b>C10 (931)</b>	Current output gain signal	100%	0–100%	Output signal value for maximum analog current output.
<b>C11 (931)</b>	Current output gain current	100%	0–100%	Output current value for maximum analog current output (e.g. 20mA)

Parameters referred to	Refer to Section
54 CA terminal function selection	6.15.3
55 Frequency monitoring reference	6.15.3
56 Current monitoring reference	6.15.3
158 AM terminal function selection	6.15.3

The parameter number in parentheses is the one for use with the parameter unit (FR-PU04 or FR-PU07).

The above parameters allow its setting to be changed during operation in any operation mode even if "0" (initial value) is set in Pr. 77 "Parameter write selection".

#### CA terminal calibration [C0 (Pr. 900), C8 (Pr. 930) to C11 (Pr. 931)]

Terminal CA is factory-set to provide a 20mA DC output in the full-scale status of the corresponding monitor item. Calibration parameter C0 (Pr. 900) allows the output current ratios (gains) to be adjusted according to the meter scale. Note that the maximum output current is 20mA DC.

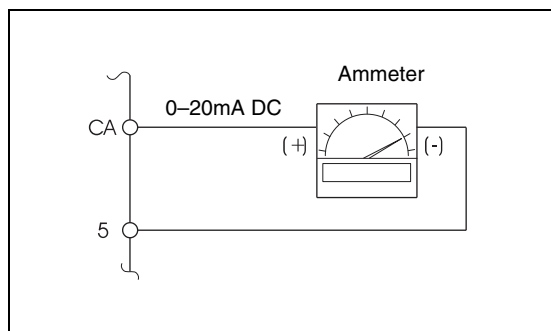

**Fig. 6-153:**  
Connecting an analog meter to the CA output

I001166E



Calibration of the zero point of the meter connected to terminal CA is performed with C9 (Pr. 930). Calibration of the maximum meter deflection is performed with C11 (Pr. 931).

The value to be associated with the zero point for the signal output to terminal CA is entered in C8 (Pr. 930). The value for the signal to be associated with the maximum analog output value (maximum deflection) is entered in C10 (Pr. 931). You can also set these parameters to use the analog meter for only a defined sub-range of the full scale of the monitor signal to be output. For example, if you only want to show the value of the output voltage between 100 and 400V (i.e. output 4mA for all voltages between 0 and 100V and 20mA for all voltages above 400V) then set C8 to 12.5% (100V is 12.5% of the maximum inverter output voltage of 800V) and C9 to 20% (corresponds to approx. 20mA at the CA terminal).

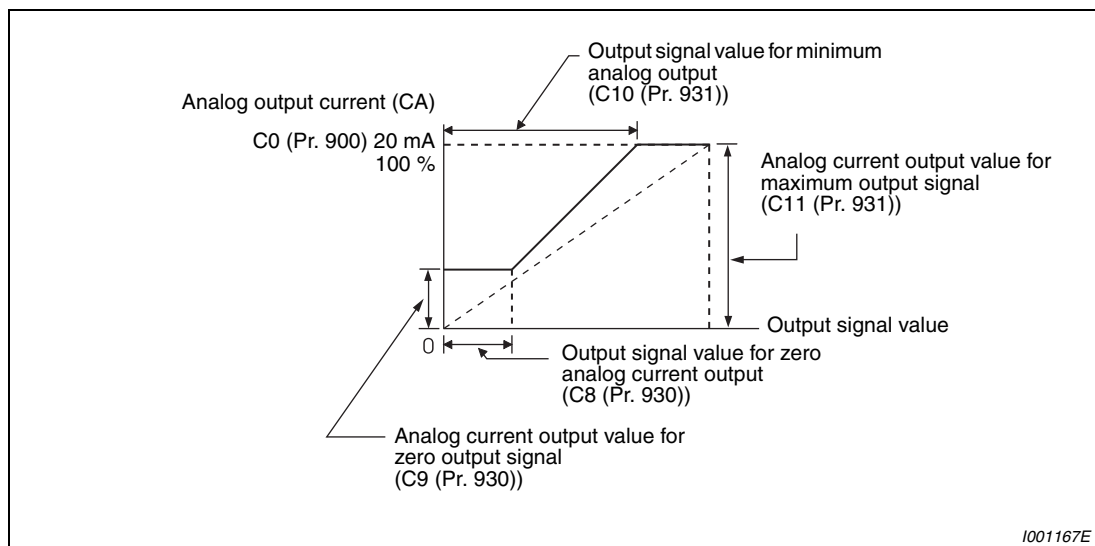

**Fig. 6-154:** CA terminal calibration

CA terminal calibration procedure:

- ① Connect an 0-20mA DC meter (DC ammeter) to inverter terminals CA and 5, taking care to correct with the correct polarity. CA is positive.
- ② Set Pr. 54 to select the monitor signal you want to output to analog output CA. To display the output frequency or the output current set Pr. 55 or Pr. 56, respectively, to the maximum frequency or current value at which you wish to output 20mA to the terminal.
- ③ Zero point calibration: The zero point of the meter is calibrated with C9 (Pr. 930). The calibration display is shown in percent. A value of 0% corresponds to approx. 0mA, a value of 20% to approx. 4mA. The value for the monitor signal up to which the minimum analog current is to be output is set with C8 (Pr. 930). Here too, the calibration display is in percent, and 100% corresponds to the full scale value of the monitor signal selected (refer to Tab. 6-93).
- ④ Start the frequency inverter in PU mode with the operation panel or the control terminals (external operation).
- ⑤ Calibrate the full deflection of the meter by selecting C0 (Pr. 900) and then operating the digital dial. Note that the value shown on the operating panel for the monitor signal associated with C0 does not change when you turn the digital dial! However, the analog current output to CA will change as you turn the dial. Confirm the calibration value found by pressing the SET key (this assigns the maximum analog current output to the displayed value of the monitor signal.)

**NOTES**

If it is not possible to adjust the signal to be used for calibration to its maximum value you can set Pr. 54 to "21". This outputs a continuous signal of approx. 20mA to terminal CA, which makes it possible to calibrate the maximum value on the meter. When C0 is used to calibrate the full meter deflection in this mode a value of "1000" is shown on the operating panel display. Afterwards you can then reset Pr. 54 to the required monitor signal setting.

Current is also output to terminal CA when the parameters are configured as follows:  
C8 (Pr. 930)  $\geq$  C10 (Pr. 931) and C9 (Pr. 930)  $\geq$  C11 (Pr. 931).

**AM terminal calibration [C1 (Pr. 901)]**

Terminal AM is factory-set to provide a 10V DC output in the full-scale status of the corresponding monitor item. Calibration parameter C1 (Pr. 901) allows the output voltage ratios (gains) to be adjusted according to the meter scale. Note that the maximum output voltage is 10V DC, the maximum output current 1mA.

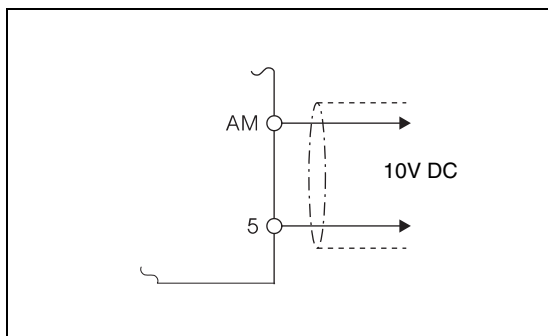
**Fig. 6-155:**

Connecting an analog meter to the AM output

1001168C

AM terminal calibration procedure:

- ① Connect an 0 to 10V DC voltmeter to inverter terminals AM and 5, taking care to correct with the correct polarity. AM is positive.
- ② Set Pr. 158 to select the monitor signal you want to output to analog output AM (refer to page 6-333). To display the output frequency or the output current set Pr. 55 or Pr. 56, respectively, to the maximum frequency or current value for which you want to output 10V to the terminal.
- ③ Start the frequency inverter in PU mode with the operation panel or the control terminals (external operation).
- ④ Calibrate the full deflection of the meter by setting C1 (Pr. 901) and then operating the digital dial. Note that the value shown on the operating panel for the monitor signal associated with C1 does not change when you turn the digital dial, but the analog current output to AM will change as you turn the dial. Confirm the calibration value found by pressing the SET key (this assigns the maximum voltage output to the displayed value of the monitor signal.)

**NOTE**

If it is not possible output the signal to be measured for calibration at its maximum value you can set Pr. 158 to "21". This outputs a continuous signal of approx. 10V to terminal AM, which makes it possible to calibrate the maximum value on the meter. When C1 is used to calibrate the full meter deflection in this mode a value of "1000" is displayed. Afterwards you can then reset Pr. 158 to the required monitor signal setting.

**How to calibrate the terminal CA when using the operation panel FR-DU07**

The following example shows how to calibrate the maximum value of the CA terminal to the 60Hz output frequency. This operation is performed in PU mode.

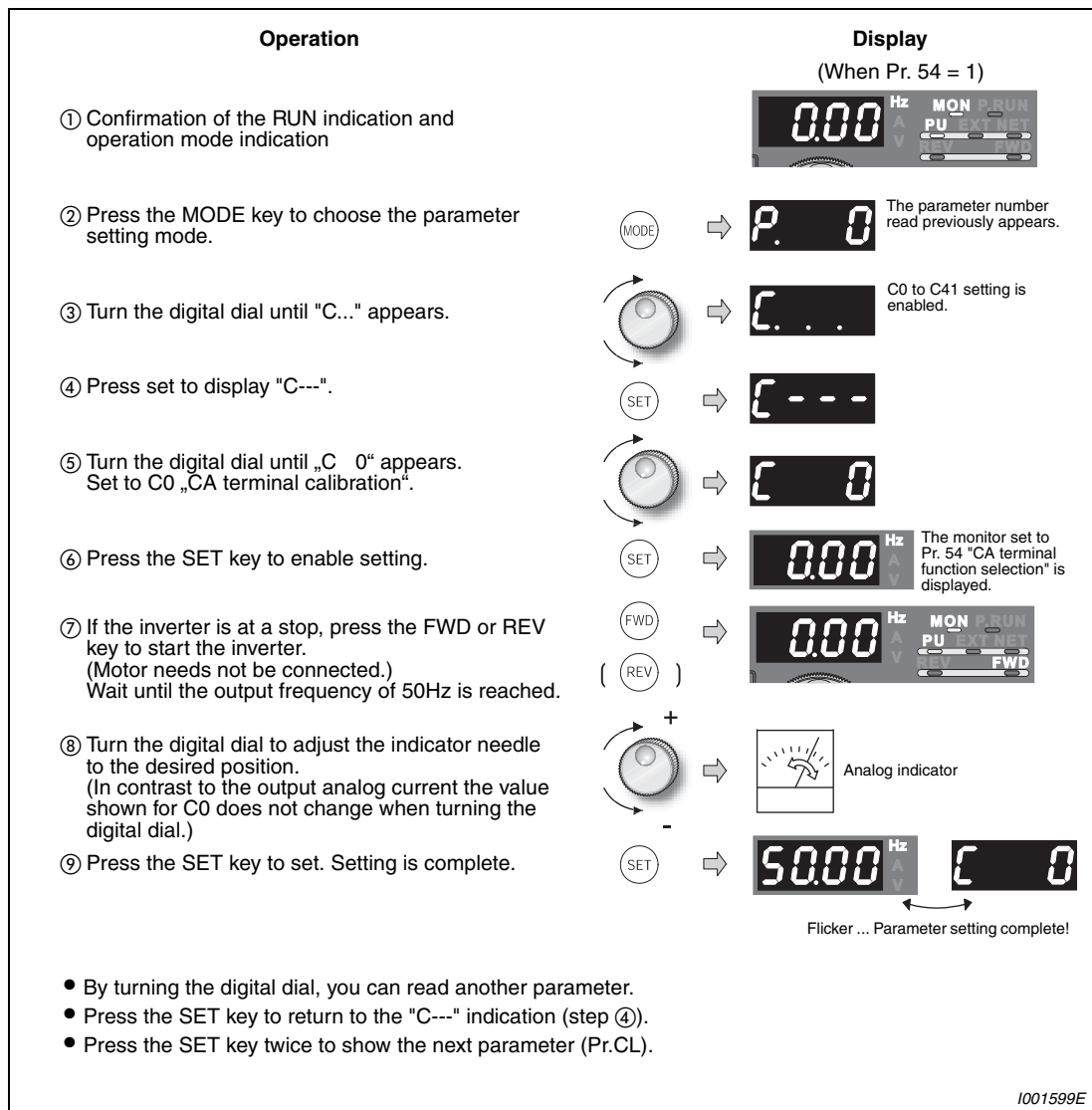

**Fig. 6-156: CA terminal calibration**

**NOTES**

- | Calibration can also be made for external operation. Set the frequency in external operation mode, and make calibration in the above procedure.
- | Calibration can be made even during operation.
- | For the operation procedure using the parameter unit (FR-PU04, FR-PU07), refer to the parameter unit instruction manual.

## 6.16 Operation selection at power failure

Purpose	Parameters that must be set		Refer to Section
At instantaneous power failure occurrence, restart inverter without stopping motor.	Automatic restart operation after instantaneous power failure	Pr. 57, Pr. 58, Pr. 162–Pr. 165, Pr. 299, Pr. 611	6.16.1
When under voltage or a power failure occurs, the inverter can be decelerated to a stop.	Power failure-time deceleration-to-stop function	Pr. 261–Pr. 266	6.16.2

### 6.16.1 Automatic restart (Pr. 57, Pr. 58, Pr. 162 to Pr. 165, Pr. 299, Pr. 611)

You can restart the inverter without stopping the motor in the following cases.

- when commercial power supply operation is switched to inverter operation
- when power comes back on after an instantaneous power failure
- when motor is coasting at start

Pr. No.	Name	Initial Value		Setting Range	Description	Parameters referred to	Refer to Section	
<b>57</b>	Restart coasting time	9999		0	00052 or less ..... 0.5s 00083–00250 ..... 1s 00310, 0,1800 ..... 3s 02160 or more ..... 5s	7 Acceleration time 21 Acceleration/ deceleration time increments 13 Starting frequency 65 Retry selection 67–69 Retry function 178–189 Input terminal function selection	6.11.1 6.11.1 6.11.2 6.17.1 6.17.1 6.14.1	
				01800 or less	0.1–5s			Set the waiting time for inverter-triggered restart after an instantaneous power failure.
				02160 or more	0.1–30s			
				9999				
<b>58</b>	Restart cushion time	1s		0–60s	Set a voltage starting time at restart.			
<b>162</b>	Automatic restart after instantaneous power failure selection	0		0	With frequency search			
				1	Without frequency search (reduced voltage system)			
				2	Encoder detection frequency search			
				10	Frequency search at every start			
				11	Reduced voltage system at every start			
				12	Encoder detection frequency search at every start			
<b>163</b>	First cushion time for restart	0s		0–20s	Set a voltage starting time at restart.			
<b>164</b>	First cushion voltage for restart	0%		0–100%	Consider using these parameters according to the load (inertia moment, torque) magnitude.			
<b>165</b>	Stall prevention operation level for restart	150% ①		0–220% ①	Consider the rated inverter current according to the overload capacity as 100% and set the stall prevention operation level during restart operation.			
<b>299</b>	Rotation direction detection selection at restarting	9999		0	Without rotation direction detection			
				1	With rotation direction detection			
				9999	When Pr. 78 = "0", the rotation direction is detected. When Pr. 78 = "1","2", the rotation direction is not detected.			
<b>611</b>	Acceleration time at a restart	01800 or less	5s	0–3600s, 9999	Set the acceleration time to reach the set frequency at a restart. Acceleration time for restart is the normal acceleration time (e.g. Pr. 7) when "9999" is set.			
		02160 or more	15s					

① When Pr. 570 Multiple rating setting ≠ "2", performing all parameter clear and inverter reset changes the initial value and setting range.

**Automatic restart after instantaneous power failure operation**

When Instantaneous power failure protection (E.IPF) and undervoltage protection (E.UVT) are activated, the inverter output is shut off. (Refer to section 7.2 for E.IPF and E.UVT.) When automatic restart after instantaneous power failure operation is set, the motor can be restarted if power is restored after an instantaneous power failure and under voltage. (E.IPF and E.UVT are not activated.) When E.IPF and E.UVT are activated, instantaneous power failure/undervoltage signal (IPF) is output.

**NOTE**

The IPF signal is assigned to the terminal IPF in the initial setting. The IPF signal can also be assigned to the other terminal by setting "2 (source logic) or 102 (sink logic)" to any of Pr. 190 to Pr. 196 "Output terminal function selection".

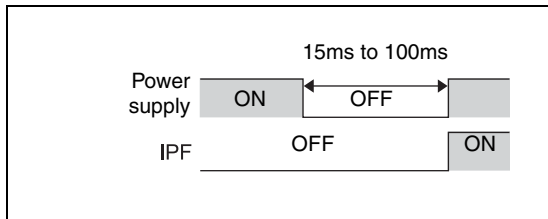

**Fig. 6-157:**  
IPF signal

1001353E

**Connection (CS signal)**

When the automatic restart after instantaneous power failure selection signal (CS) is turned on, automatic restart operation is enabled.

When Pr. 57 is set to other than "9999" (automatic restart operation enabled), the inverter will not operate if used with the CS signal remained off.

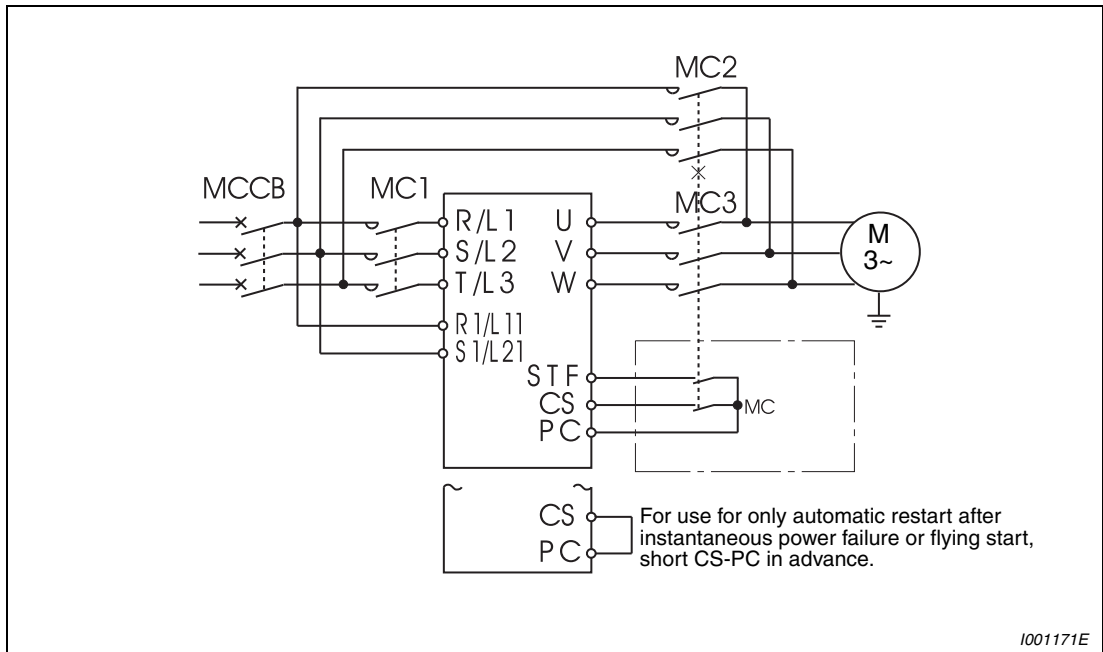

1001171E

**Fig. 6-158:** Connection example

**NOTE**

The CS signal is assigned to the terminal CS in the initial setting. By setting "6" in any of Pr. 178 to Pr. 189 (input terminal function selection), you can assign the CS signal to the other terminal.

**Automatic restart operation selection (Pr. 162, Pr. 299)**

- With frequency search

When "0" (initial value) or "10" is set in Pr. 162, the inverter smoothly starts after detecting the motor speed upon power restoration. During reverse rotation, the inverter can be restarted smoothly as the direction of rotation is detected. You can select whether to make rotation direction detection or not with Pr. 299 "Rotation direction detection selection at restarting". When capacities of the motor and inverter differ, set "0" (without rotation direction detection) in Pr. 299.

Pr. 299 Setting	Pr. 78 Setting		
	0	1	2
9999 (Initial value)	With rotation direction detection	Without rotation direction detection	Without rotation direction detection
0	Without rotation direction detection		
1	With rotation direction detection	With rotation direction detection	With rotation direction detection

**Tab. 6-98: Rotation direction direction**

Automatic restart when Pr. 162 = 0, 10 (with frequency search)

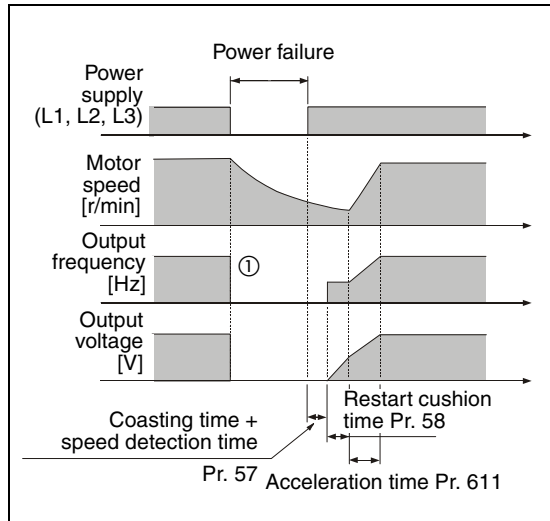

**Fig. 6-159:**  
Under V/f control or advanced magnetic flux vector control

1000722C

- ① The output shut off timing differs according to the load condition.

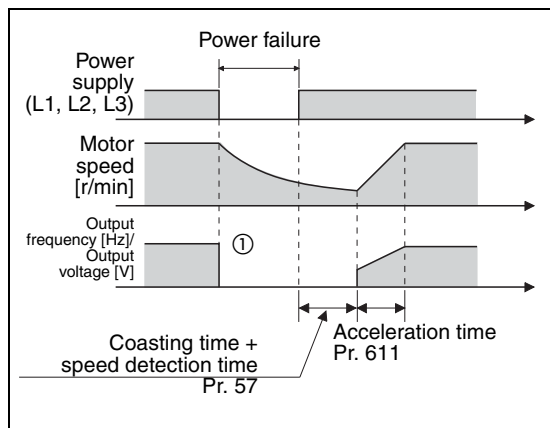

**Fig. 6-160:**  
Under real sensorless vector control

1001602E

- ① The output shut off timing differs according to the load condition.

**NOTES**

Speed detection time (frequency search) changes according to the motor speed.  
(maximum 500ms)

Frequency search errors can occur if the output capacity of the frequency inverter is one or more classes higher than that of the motor or if the motor is a special model (e.g. with a frequency rating above 60Hz). If this happens it is possible for over current error messages (OCT) to be generated during motor acceleration. In such configurations flying restarts are not possible and the frequency search function should not be used.

At motor frequencies of 10Hz or less the inverter accelerates from 0Hz to the set frequency.

If more than one motor is connected to the inverter in parallel the frequency search on automatic restart does not work correctly and over current error messages (OCT) are likely. In such configurations deactivate frequency search (set Pr. 162 to "1" or "11"). Then configure by trial and error, starting with smaller values for Pr. 164 and larger values for Pr. 163 to find out whether the motor can be started without an over current error (OCT).

Since the DC injection brake is operated instantaneously when the speed is detected at a restart, the speed may reduce if the inertia moment (J) of the load is small.

When reverse rotation is detected when Pr. 78 = 1 (reverse rotation disabled), the rotation direction is changed to forward rotation after decelerates in reverse rotation when the start command is forward rotation. The inverter will not start when the start command is reverse rotation.



● Without frequency search

When Pr. 162 = "1" or "11", automatic restart operation is performed in a reduced voltage system, where the voltage is gradually risen with the output frequency unchanged from prior to an instantaneous power failure independently of the coasting speed of the motor.

For real sensorless vector control, output frequency and voltage before instantaneous power failure prior to an instantaneous power failure independently of the coasting speed of the motor.

Automatic restart without frequency search (Pr. 162 = 1/11)

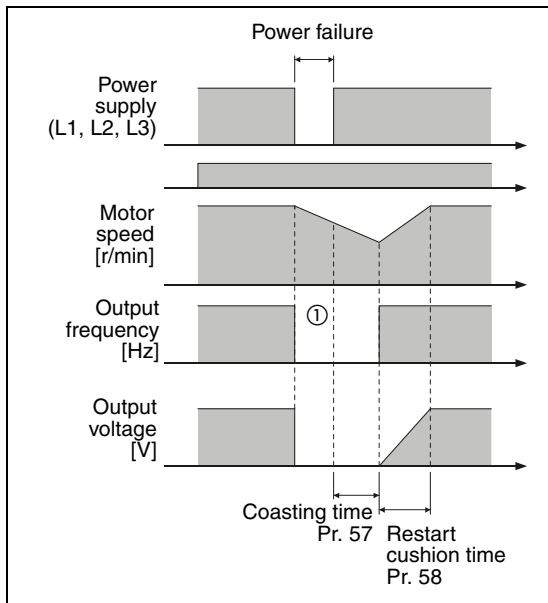

**Fig. 6-161:**  
Under V/f control or advanced magnetic flux vector control

1000647C

① The output shut off timing differs according to the load condition.

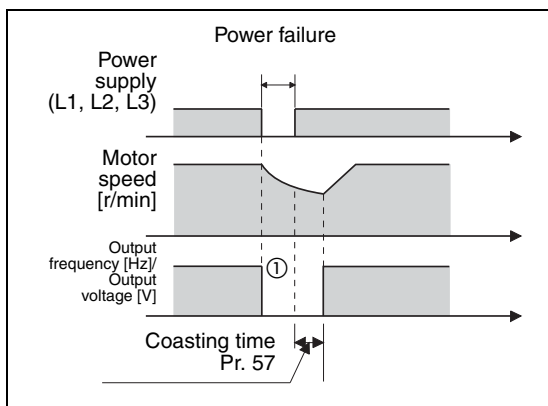

**Fig. 6-162:**  
Under real sensorless vector control

1001604E

① The output shut off timing differs according to the load condition.

**NOTE**

This system stores the output frequency prior to an instantaneous power failure and increases the voltage. Therefore, if the instantaneous power failure time exceeds 0.2s, the inverter starts at Pr. 13 "Starting frequency" (initial value = 0.5Hz) since the stored output frequency cannot be retained.

● Encoder detection frequency search

When "2 or 12" is set in Pr. 162 under encoder feedback control, the motor starts at the motor speed and in the rotation direction detected from the encoder at power restoration.

Encoder detection frequency search is performed regardless of the Pr. 162 setting under vector control.

The Pr. 58 and Pr. 299 settings are invalid for encoder detection frequency search.

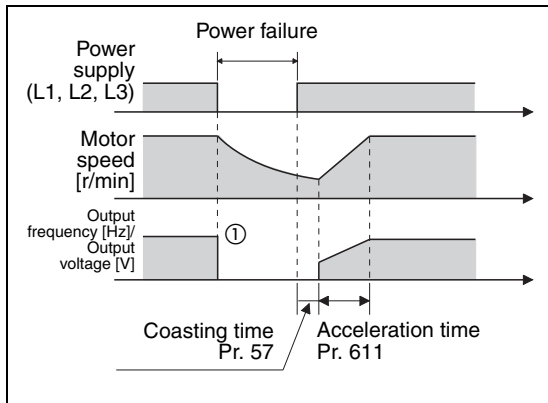

**Fig. 6-163:**  
Encoder detection frequency search

1001605E

① The output shut off timing differs according to the load condition.

**NOTE**

When encoder feedback control is invalid, setting "2 or 12" in Pr. 162 enables frequency search.

● Restart operation at every start

When Pr. 162 = "10, 11 or 12", automatic restart operation is also performed every start, in addition to the automatic restart after instantaneous power failure. When Pr. 162 = "0" or "2", automatic restart operation is performed at the first start after power supply-on, but the inverter starts at the starting frequency at the second time or later.

**Restart coasting time (Pr. 57)**

Coasting time is the time from when the motor speed is detected until automatic restart control is started.

Set Pr. 57 to "0" to perform automatic restart operation. The coasting time is automatically set to the value below. Generally this setting will pose no problems.

00052 or less . . . . 0.5s, 00083 to 00250 . . . 1s, 00310 to 01800 . . . . . 3.0s, 02160 or more . . . 5.0s

Operation may not be performed well depending on the magnitude of the moment (J) of inertia of the load or running frequency. Adjust the coasting time between 0.1s and 5s according to the load specifications.

**Restart cushion time (Pr. 58)**

Cushion time is the length of time taken to raise the voltage appropriate to the detected motor speed (output frequency prior to instantaneous power failure when Pr. 162 = "1" or "11").

Normally the initial value need not be changed for operation, but adjust it according to the magnitude of the moment (J) of inertia of the load or torque.

Pr. 58 is invalid during encoder feedback control (Pr. 162 = "2, 12"), real sensorless vector control or vector control.

**Automatic restart operation adjustment (Pr. 163 to Pr. 165, Pr. 611)**

Using Pr. 163 and Pr. 164, you can adjust the voltage rise time at a restart as shown below.

Using Pr. 165, you can set the stall prevention operation level at a restart.

Using Pr. 611, you can set the acceleration time until the set frequency is reached after automatic restart operation is performed besides the normal acceleration time.

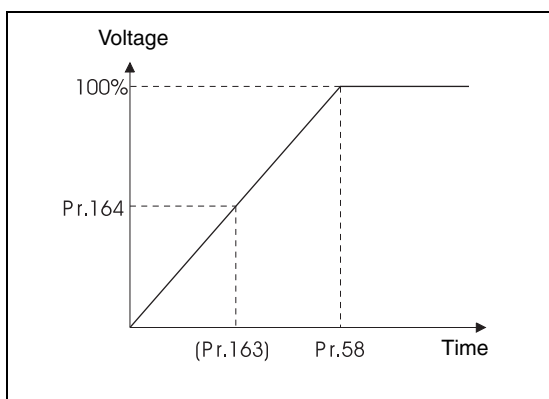

**Fig. 6-164:**  
Voltage rise at automatic restart

1001170E

**NOTE**

If the setting of Pr. 21 "Acceleration/deceleration time increments" is changed, the setting increments of Pr. 611 does not change.

**NOTES**

The CS signal is assigned to the terminal CS in the initial setting. By setting "6" in any of Pr. 178 to Pr. 189 "Input terminal function selection", you can assign the CS signal to the other terminal.

Changing the terminal assignment using Pr. 178 to Pr. 189 "Input terminal function selection" may affect the other functions. Please make setting after confirming the function of each terminal.

When automatic restart operation is selected, under voltage protection (E.UVT) and instantaneous power failure protection (E.IPF) among the alarm output signals will not be provided at occurrence of an instantaneous power failure.

The SU and FU signals are not output during a restart. They are output after the restart cushion time has elapsed.

Automatic restart operation will also be performed after a reset made by an inverter reset is canceled or when a retry is made by the retry function.

Automatic restart after instantaneous power failure function is invalid when load torque high speed frequency control (Pr. 270 = "2, 3") is set.

**CAUTION:**

***Before activating the automatic restart after power failure function please make sure that this mode is supported for the drive and permitted for your configuration.***

***When automatic restart after instantaneous power failure has been selected, the motor and machine will start suddenly (after the reset time has elapsed) after occurrence of an instantaneous power failure. Stay away from the motor and machine. When you have selected automatic restart after instantaneous power failure function, apply CAUTION seals in easily visible places.***

***Provide mechanical interlocks for MC2 and MC3. The inverter will be damaged if the power supply is input to the inverter output section.***

***Before switching power to a motor that is already rotating it is essential to check that activating the inverter with the selected control method will generate the same phase sequence as that of the rotating motor. If this is not the case the motor could be reversed unexpectedly, which can damage or even destroy the motor.***

## 6.16.2 Power failure-time deceleration-to-stop function (Pr. 261 to Pr. 266, Pr. 294)

When a power failure or under voltage occurs, the inverter can be decelerated to a stop or can be decelerated and re-accelerated to the set frequency.

Pr. No.	Name	Initial Value	Setting Range	Description	Parameters referred to	Refer to Section	
261	Power failure stop selection	0	0	Coasting to stop when under voltage or power failure occurs, the inverter output is shut off.	12 DC injection brake operation voltage 20 Acceleration/ deceleration reference frequency 21 Acceleration/ deceleration time increments 30 Regenerative function selection 57 Restart coasting time 190–196 Output terminal function selection 872 Input phase failure protection selection	6.13.1 6.11.1 6.11.1 6.13.2 6.16.1 6.14.5 6.17.3	
			1	Without under voltage avoidance			When under voltage or a power failure occurs, the inverter can be decelerated to a stop.
			11	With under voltage avoidance			
			2	Without under voltage avoidance			When under voltage or a power failure occurs, the inverter can be decelerated to a stop. If power is restored during a power failure, the inverter accelerates again.
			12	With under voltage avoidance			
262	Subtracted frequency at deceleration start	3Hz	0–20Hz	Normally operation can be performed with the initial value unchanged. But adjust the frequency according to the magnitude of the load specifications (moment of inertia, torque).			
263	Subtraction starting frequency	50Hz	0–120Hz	When output frequency ≥ Pr. 263: Decelerate from the speed obtained from output frequency minus Pr. 262. When output frequency < Pr. 263: Decelerate from output frequency			
			9999	Decelerate from the speed obtained from output frequency minus Pr. 262.			
264	Power-failure deceleration time 1	5s	0–3600/360s <sup>①</sup>	Set a deceleration slope down to the frequency set in Pr. 266.			
265	Power-failure deceleration time 2	9999	0–3600/360s <sup>①</sup>	Set a deceleration slope below the frequency set in Pr. 266.			
			9999	Same slope as in Pr. 264			
266	Power failure deceleration time switch-over frequency	50Hz	0–400Hz	Set the frequency at which the deceleration slope is switched from the Pr. 264 setting to the Pr. 265 setting.			
294	UV avoidance voltage gain	100%	0–200%	Adjust the response level during under-voltage avoidance operation. A larger setting will improve responsiveness to the bus voltage change. Since the regeneration amount is large when the inertia is large, decrease the setting value.			

① When the setting of Pr. 21 "Acceleration/deceleration time increments" is "0" (initial value), the setting range is "0 to 3600s" and the setting increments are "0.1s", and when the setting is "1", the setting range is "0 to 360s" and the setting increments are "0.01s"

**Connection and parameter setting**

Remove the jumpers across terminals R/L1-R1/L11 and across terminals S/L2-S1/L21, and connect the terminal R1/L11 to the terminal P/+ and the terminal S1/L21 to the terminal N/- (the inverter's internal control circuit is then powered by the DC bus).

When Pr. 261 is set to "1" or "2", the inverter decelerates to a stop if an under voltage or power failure occurs.

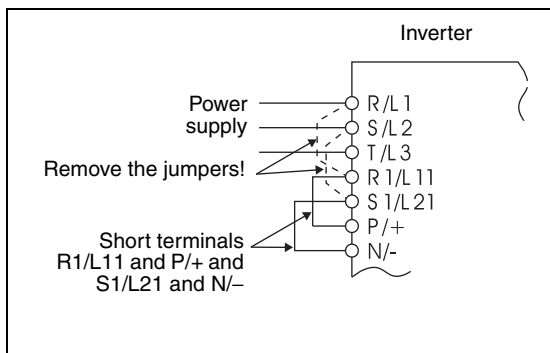

**Fig. 6-165:**  
Connection

I001172E

**Operation outline of deceleration to stop at power failure**

If an under voltage or power failure occurs, the output frequency is dropped by the frequency set to Pr. 262 .

Deceleration is made in the deceleration time set to Pr. 264. (The deceleration time setting is the time required from Pr. 20 "Acceleration/deceleration reference frequency" to a stop.)

When the frequency is low and enough regeneration energy is not provided, for example, the deceleration time (slope) from Pr. 265 to a stop can be changed.

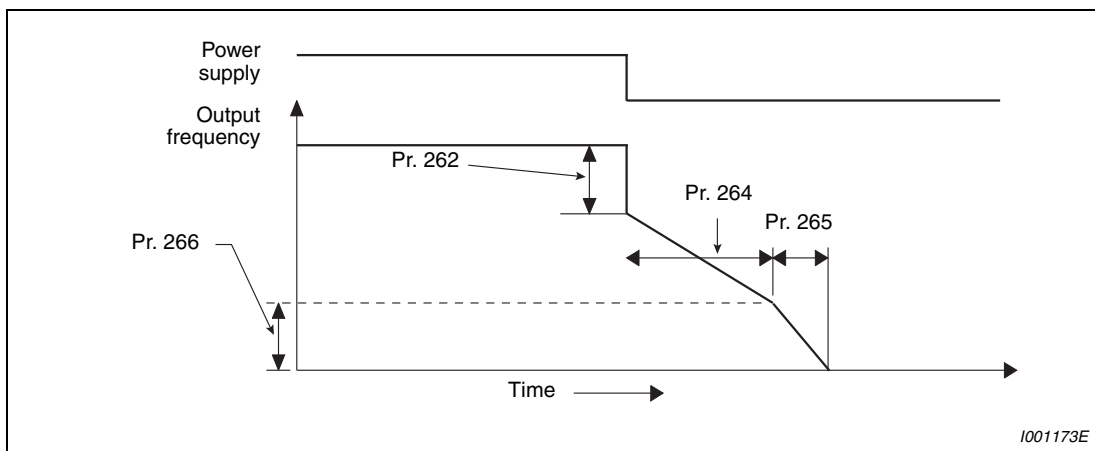

I001173E

**Fig. 6-166:** Parameters for stop selection at power failure

**Power failure stop mode (Pr. 261 = 1 or 11)**

If power is restored during power failure deceleration, deceleration to a stop is continued and the inverter remains stopped. To restart, turn off the start signal once, then turn it on again.

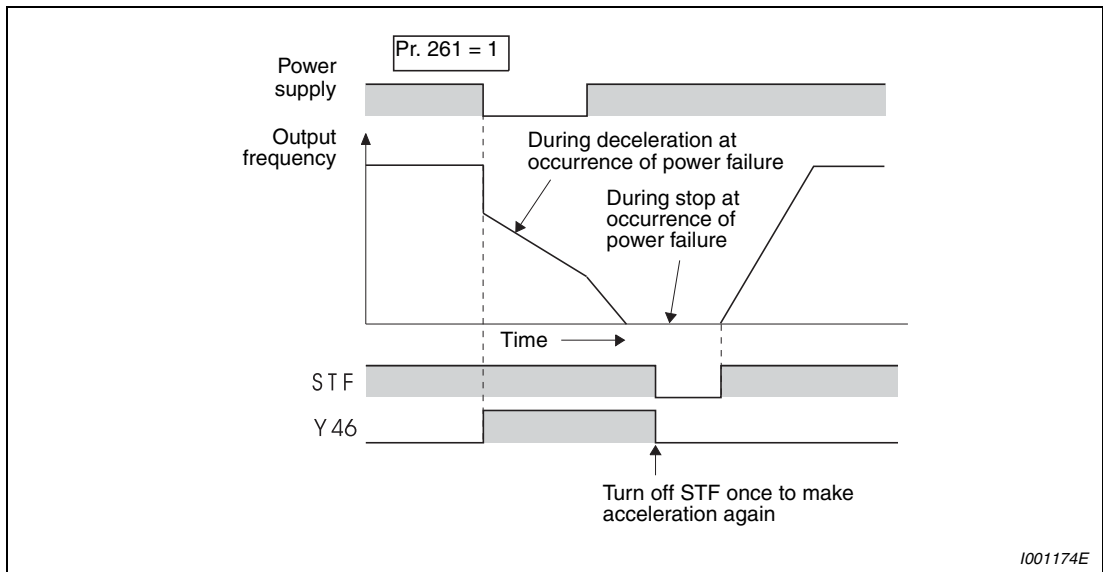
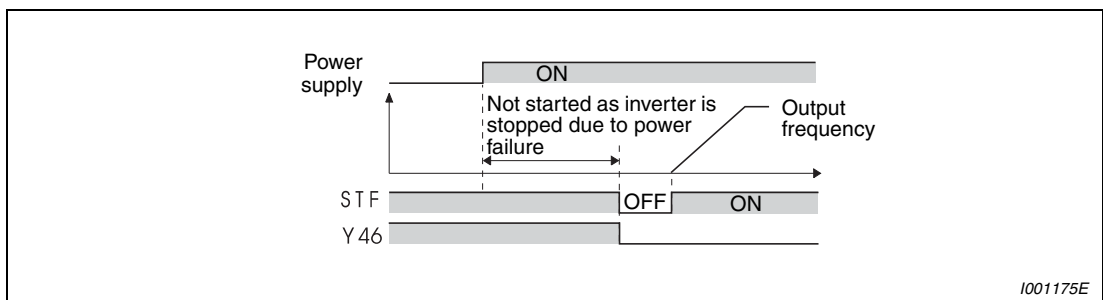

**Fig. 6-167: Power restoration**

**NOTES**

When automatic restart after instantaneous power failure is selected (Pr. 57 ≠ 9999), deceleration to stop function is invalid and the restart after instantaneous power failure operation is performed.

After a power failure stop, the inverter will not start if the power supply is switched on with the start signal (STF/STR) input. After switching on the power supply, turn off the start signal once and then on again to make a start.



**Fig. 6-168: Restart at power restoration**

**Original operation continuation at instantaneous power failure function (Pr. 261 = 2 or 12)**

When power is restored during deceleration after an instantaneous power failure, acceleration is made again up to the set frequency.

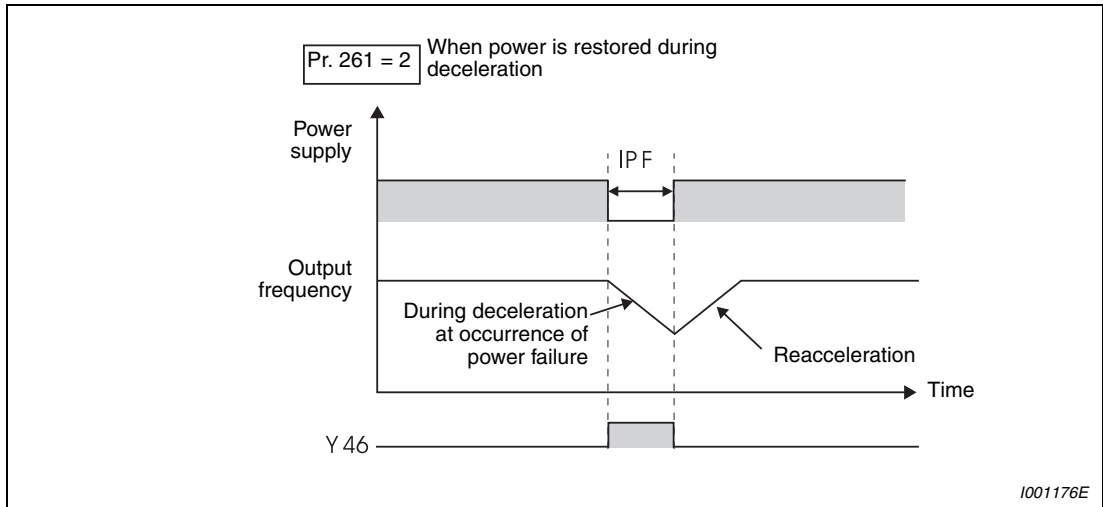

**Fig. 6-169:** Operation continuation at instantaneous power failure

When this function is used in combination with the automatic restart after instantaneous power failure operation, deceleration can be made at a power failure and acceleration can be made again after power restoration. When power is restored after a stop by deceleration at an instantaneous power failure, automatic restart operation is performed if automatic restart after instantaneous power failure has been selected (Pr. 57 ≠ 9999).

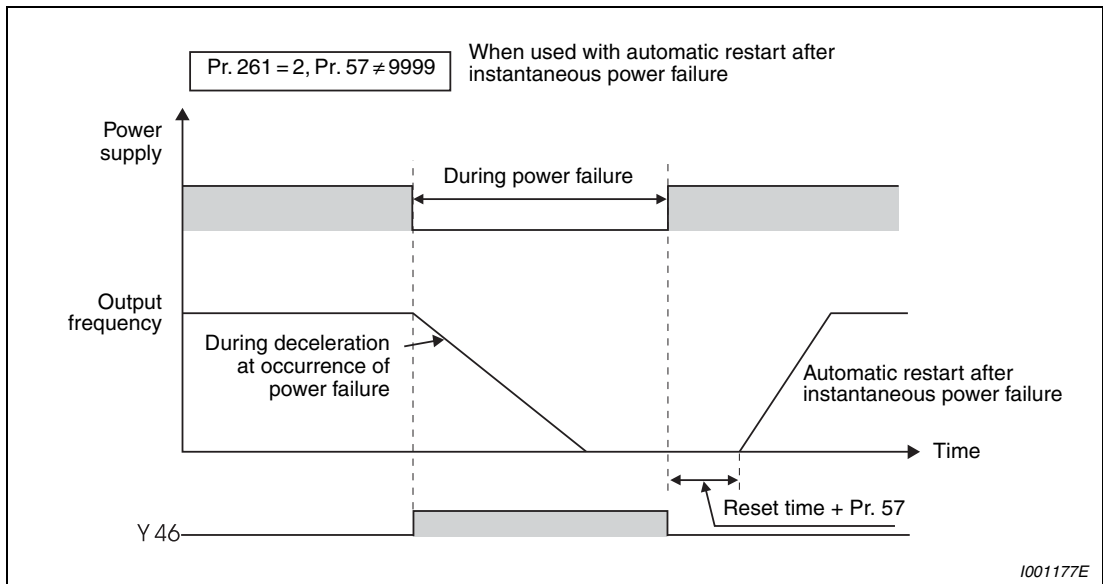

**Fig. 6-170:** Operation continuation at instantaneous power failure



**Undervoltage avoidance function (Pr. 261 = 11 or 12, Pr. 294)**

When Pr. 261 = "11, 12", the deceleration time is automatically adjusted (shortened) to prevent undervoltage from occurring during deceleration at an instantaneous power failure.

Adjust the slope of frequency decrease and response level with Pr. 294. A larger setting will improve responsiveness to the bus voltage.

Since the regeneration amount is large when the inertia is large, decrease the setting value.

**NOTE**

Undervoltage avoidance function is invalid during torque control by real sensorless vector control. When Pr. 261 = "11 (12)", the inverter operates in the same manner as when "1 (2)" is set in Pr. 261.

**Power failure deceleration signal (Y46)**

After deceleration at an instantaneous power failure, inverter can not start even if the start command is given. In this case, check the power failure deceleration signal (Y46 signal). (at occurrence of input phase failure protection (E.ILF), etc.)

The Y46 signal is on during deceleration at an instantaneous power failure or during a stop after deceleration at an instantaneous power failure.

For the Y46 signal, set "46 (source logic)" or "146 (sink logic)" in any of Pr. 190 to Pr. 196 (output terminal function selection) to assign the function.

**NOTES**

When Pr. 872 = 1 "Input phase failure protection provided" and Pr. 261  $\neq$  0 (power failure stop function valid), input phase failure protection (E.ILF) is not provided but power-failure deceleration is made.

When Pr. 30 "Regenerative function selection" = 2 (FR-HC, MT-HC, FR- CV is used), the power failure deceleration function is invalid.

When the (output frequency – Pr. 262) at under voltage or power failure occurrence is negative, the calculation result is regarded as 0Hz. (DC injection brake operation is performed without deceleration).

During a stop or error, the power failure stop selection is not performed.

Changing the terminal assignment using Pr. 190 to Pr. 196 "Output terminal function selection" may affect the other functions. Please make setting after confirming the function of each terminal.

**CAUTION:**

*If power-failure deceleration operation is set, some loads may cause the inverter to trip and the motor to coast. The motor will coast if enough regenerative energy is given from the motor.*

## 6.17 Operation setting at alarm occurrence

Purpose	Parameters that must be set		Refer to section
Recover by retry operation at alarm occurrence	Retry operation	Pr. 65, Pr. 67–Pr. 69	6.17.1
Output alarm code from terminal	Alarm code output function	Pr. 76	6.17.2
Do not input/output phase failure alarm	Input/output phase failure protection selection	Pr. 251, Pr. 872	6.17.3
The motor is decelerated to stop at motor thermal activation	Fault definition	Pr. 875	6.17.6

### 6.17.1 Retry function

If an alarm occurs, the inverter resets itself automatically to restart. You can also select the alarm description for a retry.

When automatic restart after instantaneous power failure is selected (Pr. 57 "Restart coasting time" ≠ 9999), restart operation is performed at retry operation as at an instantaneous power failure. (Refer to section 6.16.1 for the restart function.)

Pr. No.	Name	Initial Value	Setting Range	Description	Parameters referred to	Refer to Section
<b>65</b>	Retry selection	0	0–5	An alarm for retry can be selected.	57 Restart coasting time	6.16.1
<b>67</b>	Number of retries at alarm occurrence	0	0	No retry function		
			1–10	Set the number of retries at alarm occurrence. An alarm output is not provided during retry operation.		
			101–110	Set the number of retries at alarm occurrence. (The setting value of minus 100 is the number of retries.) An alarm output is provided during retry operation.		
<b>68</b>	Retry waiting time	50Hz	0–10s	Set the waiting time from when an inverter alarm occurs until a retry is made.		
<b>69</b>	Retry count display erase		0	Clear the number of restarts succeeded by retry.		

Retry operation automatically resets an alarm and restarts the inverter at the starting frequency when the time set in Pr. 68 elapses after the inverter stopped due to the alarm.

Retry operation is performed by setting Pr. 67 to any value other than "0". Set the number of retries at alarm occurrence in Pr. 67.

When retries fail consecutively more than the number of times set to Pr. 67, a retry count excess alarm (E.RET) occurs, stopping the inverter output. (Refer to retry failure example in Fig. 6-172.)

Use Pr. 68 to set the waiting time from when an inverter alarm occurs until a retry is made in the range 0 to 10s.

Reading the Pr. 69 value provides the cumulative number of successful restart times made by retry. The cumulative count in Pr. 69 is increased by 1 when a retry is regarded as successful after normal operation continues without alarms occurring for more than four times longer than the time set in Pr. 68 after a retry start. Writing "0" to Pr. 69 clears the cumulative count.

During a retry, the Y64 signal is on. For the Y64 signal, assign the function by setting "64" (source operation) or "164" (sink operation) to any of Pr. 190 to Pr. 196 "Output terminal function selection".

**NOTE** When terminal assignment is changed using Pr. 190 to Pr.196, the other functions may be affected. Please make setting after confirming the function of each terminal.

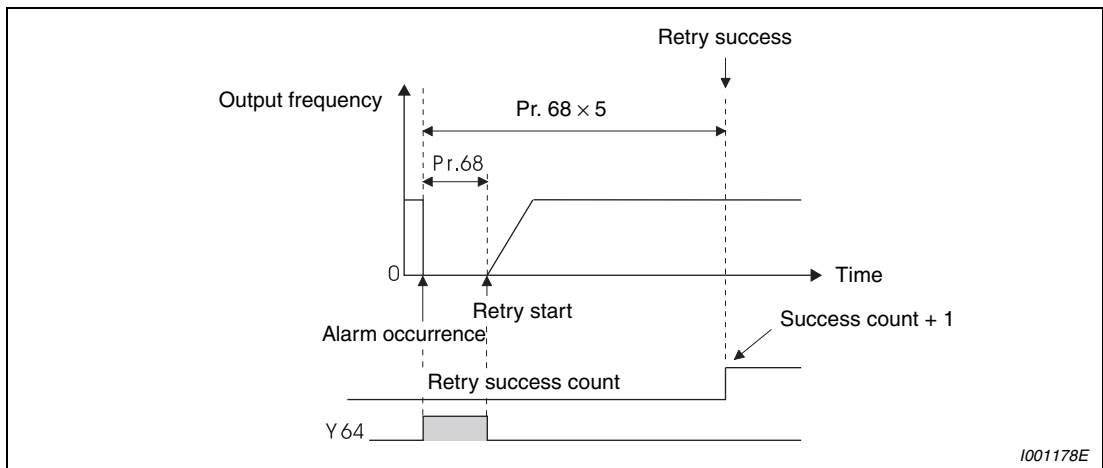

Fig. 6-171: Retry success example

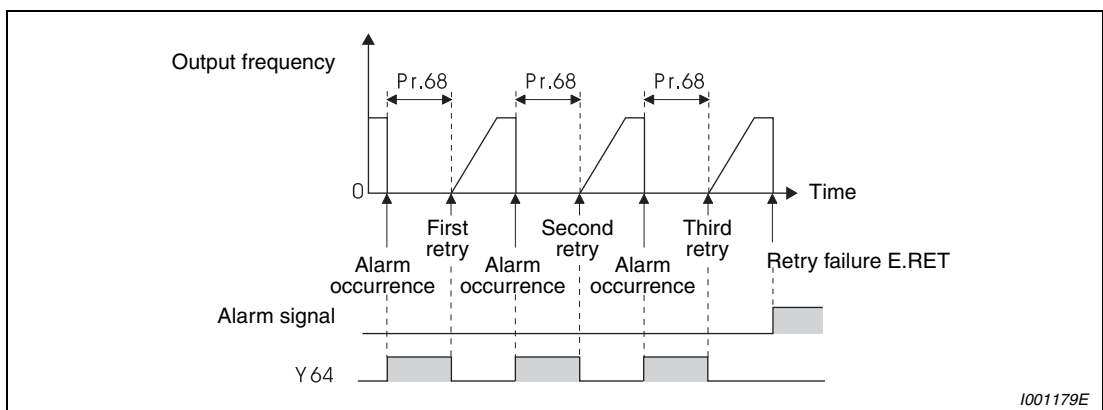

Fig. 6-172: Retry failure example

Using Pr. 65 you can select the alarm that will cause a retry to be executed. No retry will be made for the alarm not indicated.

Alarm Display for Retry	Name	Parameter 65 Setting					
		0	1	2	3	4	5
E.OC1	Over current shut-off during acceleration	✓	✓	—	✓	✓	✓
E.OC2	Over current shut-off during constant speed	✓	✓	—	✓	✓	
E.OC3	Over current shut-off during deceleration or stop	✓	✓	—	✓	✓	✓
E.OV1	Regenerative over voltage shut-off during acceleration	✓	—	✓	✓	✓	—
E.OV2	Regenerative over voltage shut-off during constant speed	✓	—	✓	✓	✓	—
E.OV3	Regenerative over voltage shut-off during deceleration or stop	✓	—	✓	✓	✓	—
E.THM	Motor overload shut-off (electronic thermal relay function)	✓	—	—	—	—	—
E.THT	Inverter overload shut-off (electronic thermal relay function)	✓	—	—	—	—	—
E.IPF	Instantaneous power failure protection	✓	—	—	—	✓	—
E.UVT	Under voltage protection	✓	—	—	—	✓	—
E.BE	Brake transistor alarm detection/Internal circuit error	✓	—	—	—	✓	—
E.GF	Output side earth (ground) fault over current protection	✓	—	—	—	✓	—
E.OHT	External thermal relay operation	✓	—	—	—	—	—
E.OLT	Stall Prevention	✓	—	—	—	✓	—
E.OPT	Option alarm	✓	—	—	—	✓	—
E.OP3	Communication option alarm	✓	—	—	—	✓	—
E.OP1	Option slot alarm	✓	—	—	—	✓	—
E.PE	Parameter storage device alarm	✓	—	—	—	✓	—
E.MB1	Brake sequence error						
E.MB2							
E.MB3							
E.MB4		✓	—	—	—	✓	—
E.MB5							
E.MB6							
E.MB7							
E.OS	Overspeed occurrence	✓	—	—	—	✓	—
E.OSD	Speed deviation excess detection	✓	—	—	—	✓	—
E.OD	Excessive position error	✓	—	—	—	✓	—
E.PTC	PTC thermistor operation	✓	—	—	—	—	—
E.CDO	Output current detection value exceeded	✓	—	—	—	✓	—
E.SER	Communication error (inverter)	✓	—	—	—	✓	—
E.ILF	Input phase failure	✓	—	—	—	✓	—

**Tab. 6-99:** Errors selected for retry

**NOTES**

For a retry error, only the description of the first alarm is stored.

When an inverter alarm is reset by the retry function at the retry time, the accumulated data of the electronic thermal relay function, regeneration converter duty etc. are not cleared. (Different from the power-on reset.)

**CAUTION:**

*When you have selected the retry function, stay away from the motor and machine unless required. They will start suddenly (after the reset time has elapsed) after occurrence of an alarm.*

*When you have selected the retry function, apply CAUTION seals in easily visible places.*

### 6.17.2 Alarm code output selection

At alarm occurrence, its description can be output as a 4-bit digital signal from determined open collector output terminals.

The alarm code can be read by a programmable controller, etc., and its corrective action can be shown on a display, etc.

Pr. No.	Name	Initial Value	Setting Range	Description	Parameters referred to	Refer to Section
76	Alarm code output selection	0	0	Without alarm code output	190–196 Output terminal function selection	6.14.5
			1	With alarm code output		
			2	Alarm state: Alarm code output No Alarm: Output of information assigned with Parameter 190–196		

By setting Pr. 76 to "1" or "2", the alarm code can be output to the output terminals.

When the setting is "2", an alarm code is output at only alarm occurrence, and during normal operation, the terminals output the signals assigned to Pr. 190 to Pr. 196 "Output terminal function selection".

The following table indicates alarm codes to be output. (0: output transistor off, 1: output transistor on)

Operation Panel Indication FR-DU07	Output of Output Terminals				Alarm Code
	SU	IPF	OL	FU	
Normal ①	0	0	0	0	0
E.OC1	0	0	0	1	1
E.OC2	0	0	1	0	2
E.OC3	0	0	1	1	3
E.OV1	0	1	0	0	4
E.OV2					
E.OV3					
E.THM	0	1	0	1	5
E.THT	0	1	1	0	6
E.IPF	0	1	1	1	7
E.UVT	1	0	0	0	8
E.FIN	1	0	0	1	9
E.BE	1	0	1	0	A
E.GF	1	0	1	1	B
E.OHT	1	1	0	0	C
E.OLT	1	1	0	1	D
E.OPT	1	1	1	0	E
E.OP1	1	1	1	0	E
Other than the above	1	1	1	1	F

Tab. 6-100: Alarm codes

① When Pr. 76 = "2", the output terminals output the signals assigned to Pr. 190 to Pr. 196.

**NOTE**

When a value other than "0" is set in Pr. 76.

When an alarm occurs, the output terminals SU, IPF, OL, FU output the signal in the above table, independently of the Pr. 190 to Pr. 196 "Output terminal function selection" settings. Please be careful when inverter control setting has been made with the output signals of Pr. 190 to Pr. 196.

### 6.17.3 Input/output phase failure protection selection (Pr. 251, Pr. 872)

You can disable the output phase failure function that stops the inverter output if one of the inverter output side (load side) three phases (U, V, W) opens.

The input phase failure protection selection of the inverter input side (R/L1, S/L2, T/L3) can be made valid.

Pr. No.	Name	Initial Value	Setting Range	Description	Parameters referred to	Refer to Section
251	Output phase failure protection selection	1	0	Without output phase failure protection	261 Power failure stop selection	6.16.2
			1	With output phase failure protection		
872	Input phase failure protection selection	0	0	Without input phase failure protection		
			1	With input phase failure protection		

#### Output phase failure protection selection (Pr. 251)

When Pr. 251 is set to "0", output phase failure protection (E.LF) becomes invalid.

#### Input phase failure protection selection (Pr. 872)

When Pr. 872 is set to "1", input phase failure protection (E.ILF) is provided if a phase failure of one phase among the three phases is detected for 1s continuously.

#### NOTES

If an input phase failure has occurred when Pr. 872 = 1 "Input phase failure protected" and a value other than "0" (power failure stop function valid) is set in Pr. 261, input phase failure protection (E.ILF) is not provided but power-failure deceleration is made.

When an input phase failure occurs in the R/L1 and S/L2 phases, input phase failure protection is not provided but the inverter output is shut off.

If an input phase failure continues for a long time during inverter operation, the converter section and capacitor lives of the inverter will be shorter.

### 6.17.4 Overspeed detection (Pr. 374)

Pr. No.	Name	Initial Value	Setting Range	Description	Parameters referred to	Refer to Section
<b>374</b>	Overspeed detection level	140Hz	0-400Hz	When the motor speed reaches or exceeds the speed set in Pr. 374 during encoder feedback control, real sensorless vector control, or vector control, over speed (E.OS) occurs and stops the inverter output.	—	

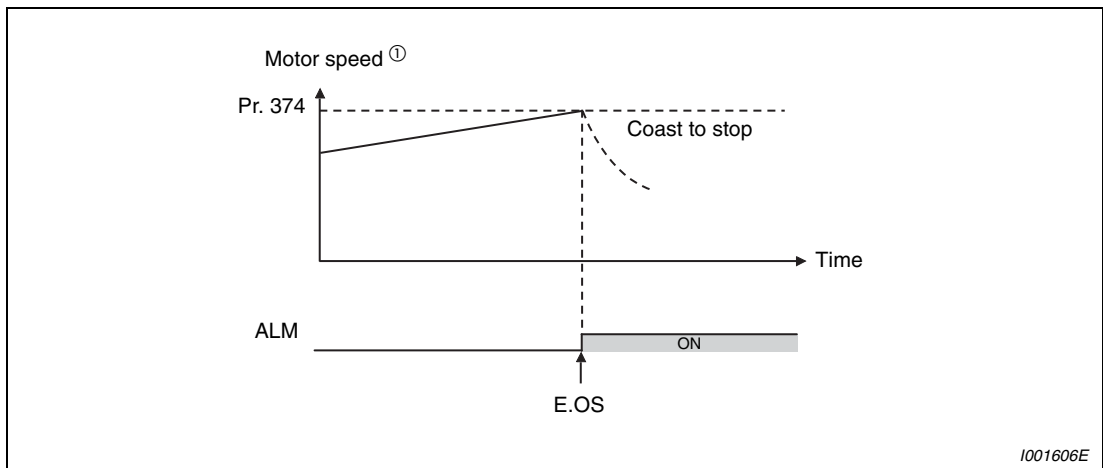

**Fig. 6-173:** Overspeed detection level and alarm occurrence

① The output frequency and Pr. 374 are compared during real sensorless vector control.

### 6.17.5 Encoder signal loss detection (Pr. 376) V/F Magnetic flux Vector

When the encoder signal is lost during encoder feedback control, orientation control, or vector control, signal loss detection (E.ECT) is activated to stop the inverter output.

Pr. No.	Name	Initial Value	Setting Range	Description	Parameters referred to	Refer to Section
<b>376</b>	Encoder signal loss detection enable/disable selection ①	0	0	Signal loss detection is invalid	—	
			1	Signal loss detection is valid		

① Setting can be made only when the FR-A7AP is mounted.



## 6.17.6 Fault definition (Pr. 875)

When motor thermal protection is activated, an alarm can be output after the motor decelerates to a stop.

Pr. No.	Name	Initial Value	Setting Range	Description	Parameters referred to	Refer to Section
875	Fault definition	0	0	Normal operation	190-196 Output terminal function selection	6.14.5
			1	The motor decelerates to stop when motor thermal protection is activated.		

### Output is immediately shutoff at occurrence of any alarm (PR. 875 = 0, initial value)

Output is immediately shutoff and an alarm output is provided at alarm occurrence.

### The motor decelerates to stop when motor thermal protection is activated (Pr. 875 = 1)

When external thermal relay (E.OHT/OHT), motor overload shutoff (electronic thermal relay function) (E.THM/THM) or PTC thermistor (E.PTC/PTC) is activated, turning on the minor fault output 2 signal (ER) starts the motor to decelerate and an alarm is provided after deceleration to a stop.

When the ER signal turns on, decrease load, etc. to allow the inverter to decelerate.

At occurrence of an alarm other than OHT, THM and PTC, output is immediately shut off and an alarm is output.

Set "97 (source logic) or 197 (sink logic)" in Pr. 190 to Pr. 196 (output terminal function selection) and assign the ER signal to the output terminal.

This function is invalid during position control.

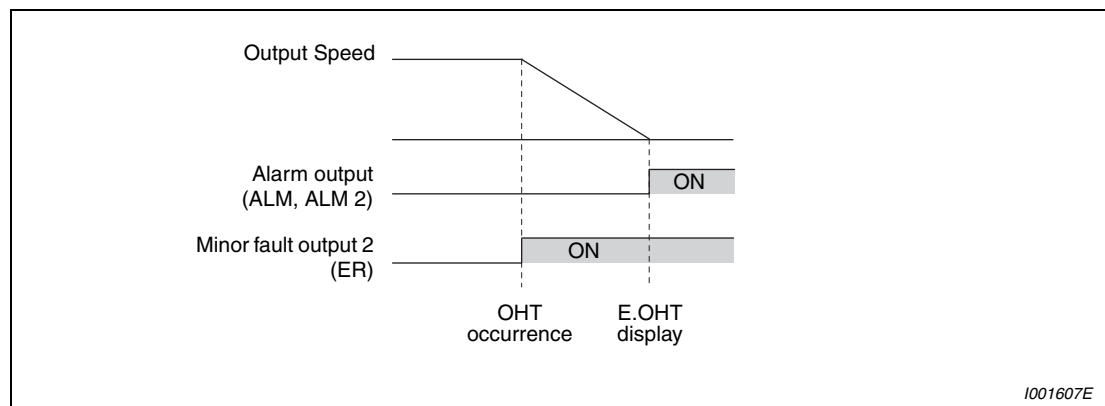

**Fig. 6-174:** Alarm output (Pr. 875 = 1)

### NOTES

The value "0" is recommended for the system in which the motor continues running without deceleration due to a large torque on the load side.

Changing the terminal assignment using Pr. 190 to Pr. 196 (output terminal function selection) may affect the other functions. Make setting after confirming the function of each terminal.

## 6.18 Energy saving operation and energy saving monitor

Purpose	Parameters that must be set		Refer to Section
Energy saving operation	Energy saving operation and optimum excitation control	Pr. 60	6.18.1
How much energy can be saved	Energy saving monitor	Pr. 52, Pr. 54, Pr. 158, Pr. 891–Pr. 899	6.18.2

### 6.18.1 Energy saving control and optimum excitation control (Pr. 60)

Without a fine parameter setting, the inverter automatically performs energy saving operation. This inverter is optimum for fan and pump applications.

Pr. No.	Name	Initial Value	Setting Range	Description	Parameters referred to	Refer to Section
60	Energy saving control selection	0	0	Normal operation mode	—	
			4	Energy saving operation mode		

① When parameter is read using the FR-PU04, a parameter name different from an actual parameter is displayed.

#### Energy saving operation mode (Pr. 60 = 4)

When "4" is set in Pr. 60, the inverter operates in the energy saving operation mode.

In the energy saving operation mode, the inverter automatically controls the output voltage to minimize the inverter output voltage during a constant operation. This inverter is appropriate for machines, such as a fan and a pump, which operate for long hours at a constant speed.

#### NOTE

For applications a large load torque is applied to or machines repeat frequent acceleration/ deceleration, an energy saving effect is not expected.

When the energy saving mode is selected (parameter 60 = 4 ), deceleration time may be longer than the setting value. Since over voltage alarm tends to occur as compared to the constant torque load characteristics, set a longer deceleration time.

The energy saving operation mode and optimum excitation control function only under V/f control. When a value other than "9999" is set in Pr. 80 "Motor capacity (simple magnetic flux vector control)", the energy saving mode and optimum excitation control are invalid.

The energy saving operation mode functions only under V/f control. When the advanced magnetic flux vector control, real sensorless vector control and vector control are selected, the energy saving mode is invalid.

Since output voltage is controlled in energy saving operation mode and by optimum excitation control, output current may slightly increase.

## 6.18.2 Energy saving monitor (Pr. 891 to Pr. 899)

From the power consumption estimated value during commercial power supply operation, the energy saving effect by use of the inverter can be monitored/output.

Pr. No.	Name	Initial Value	Setting Range	Description	Parameters referred to	Refer to Section
<b>52</b>	DU/PU main display data selection	0 (Output frequency)	0/5-14/17-20/ 22-25/32-35/ 50-57/100	50: Power saving monitor 51: Cumulative saving power monitor	3 Base frequency 52 DU/PU main display data selection 54 CA terminal function selection 158 AM terminal function selection	6.9.1 6.15.2 6.15.3 6.15.3
<b>54</b>	CA terminal function selection	1 (Output frequency)	1-3/5-14/17/18/ 21/24/32-34/50/ 52/53/70	50: Power saving monitor		
<b>158</b>	AM terminal function selection					
<b>891</b>	Cumulative power monitor digit shifted times	9999	0-4  9999	Set the number of times to shift the cumulative power monitor digit. Clamp the monitoring value at maximum.  No shift Clear the monitor value when it exceeds the maximum value.		
<b>892</b>	Load factor	100%	30-150%	Set the load factor for commercial power-supply operation. Multiplied by the power consumption rate (page 6-368) during commercial power supply operation.		
<b>893</b>	Energy saving monitor reference (motor capacity)	Applied motor Capacity	01800 or less 0.1-55kW 02160 or more 0-3600W	Set the motor capacity (pump capacity). Set when calculating power saving rate, average power saving rate value, commercial operation power.		
<b>894</b>	Control selection during commercial power-supply operation	0	0 1 2 3	Discharge damper control (fan) Inlet damper control (fan) Valve control (pump) Commercial power-supply drive (fixed value)		
<b>895</b>	Power saving rate reference value	9999	0 1 9999	Consider the value during commercial power-supply operation as 100% Consider the Pr. 893 setting as 100%. No function		
<b>896</b>	Power unit cost	9999	0-500 9999	Set the power unit cost. Display the power saving amount charge on the energy saving monitor. No function		
<b>897</b>	Power saving monitor average time	9999	0 1-1000h 9999	Average for 30 minutes Average for the set time No function		
<b>898</b>	Power saving cumulative monitor clear	9999	0 1 10 9999	Cumulative monitor value clear Cumulative monitor value hold Totalization continued (communication data upper limit: 9999) Totalization continued (communication data upper limit: 65535)		
<b>899</b>	Operation time rate (estimated value)	9999	0-100% 9999	Use for calculation of annual power saving amount. Set the annual operation ratio (consider 365 days × 24hr as 100%). No function		

The above parameters allow its setting to be changed during operation in any operation mode even if "0" (initial value) is set in Pr. 77 "Parameter write selection".

**Energy saving monitor list**

The following table provides the items that can be monitored by the power saving monitor (Pr. 52 = Pr. 54 = Pr. 158 = 50). (Only ① "Power saving" and ③ "Power saving average value" can be output to Pr. 54 (terminal CA) and Pr. 158 (terminal AM)).

Energy Saving Monitor Item	Description and Formula	Unit	Parameter Setting			
			Pr. 895	Pr. 896	Pr. 897	Pr. 899
① Power saving	Difference between the estimated value of power necessary for commercial power supply operation and the input power calculated by the inverter Power during commercial power supply operation – input power monitor	0.01kW/ 0.1kW <sup>③</sup>	9999			
② Power saving rate	Ratio of power saving on the assumption that power during commercial power supply operation is 100% $\frac{\text{① Power saving}}{\text{Power during commercial power supply operation}} \times 100$	0.1%	0	—	9999	
	Ratio of power saving on the assumption that Pr. 893 is 100% $\frac{\text{① Power saving}}{\text{Pr. 893}} \times 100$		1			
③ Power saving average value	Average value of power saving amount per hour during predetermined time (Pr. 897) $\frac{\sum (\text{① Power saving} \times \Delta t)}{\text{Pr. 897}}$	0.01kW/ 0.1kW <sup>③</sup>	9999			—
④ Power saving rate average value	Ratio of power saving average value on the assumption that the value during commercial power supply operation is 100% $\frac{\sum (\text{② Power saving rate} \times \Delta t)}{\text{Pr. 897}} \times 100$	0.1%	0	9999	0 to 1000h	
	Ratio of power saving average value on the assumption that Pr. 893 is 100% $\frac{\text{③ Power saving average value}}{\text{Pr. 893}} \times 100$		1			
⑤ Power savings amount average value	Power saving average value represented in terms of charge $\text{③ Power saving average value} \times \text{Pr. 896}$	0.01/0.1 <sup>③</sup>	—	0 to 500		

**Tab. 6-101: Power saving monitor list**

The following table shows the items which can be monitored by the cumulative saving power monitor (Pr. 52 = 51). (The monitor value of the cumulative monitor can be shifted to the right with Pr. 891 "Cumulative power monitor digit shifted times".)

	Energy Saving Monitor Item	Description and Formula	Unit	Parameter Setting			
				Pr. 895	Pr. 896	Pr. 897	Pr. 899
⑥	Power saving amount	Power saving is added up per hour. $\Sigma(\text{① Power saving} \times \Delta t)$	0.01kWh/ 0.1kWh ① ② ③	—	9999		9999
⑦	Power saving amount charge	Power saving amount represented in terms of charge $\text{⑥ Power saving amount} \times \text{Pr. 896}$	0.01/ 0.1 ① ③	—	0 to 500		
⑧	Annual power saving amount	Estimated value of annual power saving amount $\frac{\text{⑥ Power saving amount}}{\text{Operation time during accumulation of power saving amount}} \times 24 \times 365 \times \frac{\text{Pr. 899}}{100}$	0.01kWh/ 0.1kWh ① ② ③	—	9999	—	0 to 100%
⑨	Annual power saving amount charge	Annual power saving amount represented in terms of charge $\text{⑧ Annual power saving amount} \times \text{Pr. 896}$	0.01/ 0.1 ① ③	—	0 to 500		

**Tab. 6-101: Cumulative saving power monitor list**

- ① For communication (RS-485 communication, communication option), the display increments are "1". For example, the communication data is "10" for "10.00kWh".
- ② When using the parameter unit (FR-PU04 or FR-PU07), "kW" is displayed.
- ③ The setting depends on capacities. (01800 or less/02160 or more)

**NOTES**

As the operation panel (FR-DU07) is 4-digit display, it displays in "0.1" increments since a carry occurs, e.g. "100.0", when a monitor value in "0.01" increments exceeds "99.99". The maximum display is "9999".

As the operation panel (FR-PU04 or FR-PU07) is 5-digit display, it displays in "0.1" increments since a carry occurs, e.g. "1000.0", when a monitor value in "0.01" increments exceeds "999.99". The maximum display is "99999".

The upper limit of communication (RS-485 communication, communication option) is "65535" when Pr. 898 "Power saving cumulative monitor clear" = 9999. The upper limit of "0.01" increments monitor is "655.35" and that of "0.1" increments monitor is "6553.5".

### Power saving instantaneous monitor (① Power savings and ② Power saving rate)

On the power saving monitor ①, an energy saving effect as compared to the power consumption during commercial power supply operation (estimated value) is calculated and displays on the main monitor.

In the following case, the power saving monitor ① is "0":

- Calculated values of the power saving monitor are negative values.
- During the DC injection brake operation.
- Motor is not connected (output current monitor is 0A).

On the power saving rate monitor ②, setting "0" in Pr. 895 "Power saving rate reference value" displays the power saving rate on the assumption that power (estimated value) during commercial power supply operation is 100%. When Pr. 895 = 1, the power saving rate on the assumption that the Pr. 893 "Energy saving monitor reference (motor capacity)" value is 100% is displayed.

### Power saving average value monitor (③ power saving average value, ④ average power saving rate value, ⑤ power saving amount average value)

Power saving average value monitor can be displayed when a value other than "9999" is set in Pr. 897 "Power saving monitor average time".

The power saving average value monitor ③ displays the average value per unit time of the power saving amount at averaging.

The average value is updated every time an average time has elapsed after the Pr. 897 setting is changed, power is turned on or the inverter is reset, assuming as a starting point. The power savings average value update timing signal (Y92) is inverted every time the average value is updated.

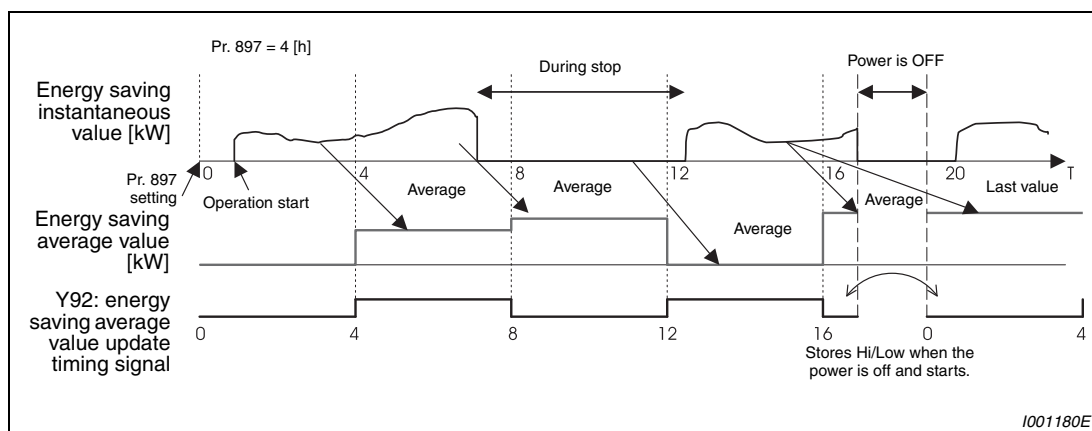

Fig. 6-175: Update of the average value

The power saving average value monitor ④ displays the average value per unit time of power saving rate ② at every average time by setting "0" or "1" in Pr. 895 "Power saving rate reference value".

By setting the charge (power unit) per 1kWh of power amount in Pr. 896 "Power unit cost", the power saving amount average value monitor ⑤ displays the charge relative to the power saving average value (power saving average value ③ × Pr. 896).

**Cumulative saving power monitor (⑥ power saving amount, ⑦ power saving amount charge, ⑧ annual power saving amount, ⑨ annual power saving amount charge)**

On the cumulative saving power monitor, the monitor data digit can be shifted to the right by the number set in Pr. 891 "Cumulative power monitor digit shifted times". For example, if the cumulative power value is 1278.56kWh when Pr. 891 = 2, the PU/DU display is "12.78" (display in 100kWh increments) and the communication data is "12". If the maximum value is exceeded at Pr. 891 = 0 to 4, the power is clamped at the maximum value, indicating that a digit shift is necessary. If the maximum value is exceeded at Pr. 891 = 9999, the power returns to "0" and is recounted. The other monitors are clamped at the display maximum value.

The cumulative saving power monitor ⑥ can measure the power amount during a predetermined period. Measure according to the following steps:

- ① Write "9999" or "10" in Pr. 898 "Power saving cumulative monitor clear".
- ② Write "0" in Pr. 898 at measurement start timing to clear the cumulative saving power monitor value and start totalization of power saving.
- ③ Write "1" in Pr. 898 at measurement end timing to hold the cumulative saving power monitor value.

**NOTE**

The cumulative saving power monitor value is stored every hour. Hence, when the power supply is switched on again within one hour after it was switched off, the previously stored monitor value is displayed and totalization starts. (The cumulative monitor value may decrease.)

**Power estimated value of commercial power supply operation (Pr. 892, Pr. 893, Pr. 894)**

Select the commercial power supply operation pattern from among the four patterns of discharge damper control (fan), inlet damper control (fan), valve control (pump) and commercial power supply drive, and set it to Pr. 894 "Control selection during commercial power-supply operation".

Set the motor capacity (pump capacity) to Pr. 893 "Energy saving monitor reference (motor capacity)".

The power consumption rate (%) during commercial power supply operation is estimated from the operation pattern and the ratio of speed to rating (current output frequency/Pr. 3 "Base frequency") in the following chart..

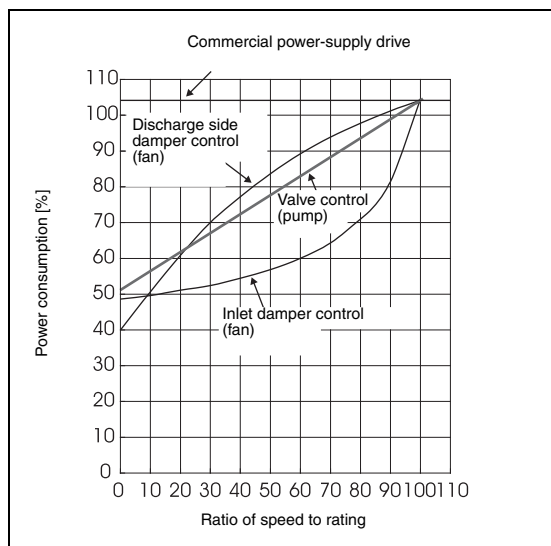

**Fig. 6-176:**  
Characteristic of the power consumption

1001181C

From the motor capacity set in Pr. 893 and Pr. 892 "Load factor", the power estimated value (kW) during commercial power supply operation is found by the following formula:

$$\text{Power estimated value [kW] during commercial power supply operation} = \text{Pr. 893 [kW]} \times \frac{\text{Power consumption [\%]}}{100} \times \frac{\text{Pr. 892 [\%]}}{100}$$

**NOTE**

Since the speed does not increase above the power supply frequency in commercial power supply operation, it becomes constant when the output frequency rises to or above Pr. 3 "Base frequency".



**Annual power saving amount, power charge (Pr. 899)**

By setting the operation time rate [%] (ratio of time when the motor is actually driven by the inverter during a year) to Pr. 899, the annual energy saving effect can be predicted.

When the operation pattern is predetermined to some degree, the estimated value of the annual power saving amount can be found by measurement of the power saving amount during a given measurement period. Refer to the following and set the operation time rate.

- ① Predict the average time [h/day] of operation in a day.
- ② Find the annual operation days [days/year]. (Monthly average operation days × 12 months)
- ③ Calculate the annual operation time [h/year] from ① and ②.  
Annual operation time = Average time [h/day] × Operation days [days/year]
- ④ Calculate the operation time rate and set it to Pr. 899.

$$\text{Operation time rate [\%]} = \frac{\text{Annual operation time [h/year]}}{24 \text{ [h/day]} \times 365 \text{ [days/year]}} \times 100 \text{ [\%]}$$

**Example** ▾

Operation time rate setting example:

When operation is performed for about 21 hours per day and the monthly average operation days are 16 days.

$$\text{Annual operation time} = 21 \text{ [h/day]} \times 16 \text{ [days/month]} \times 12 \text{ month} = 4032 \text{ [h/year]}$$

$$\text{Operation time rate [\%]} = \frac{4032 \text{ [h/year]}}{24 \text{ [h/day]} \times 365 \text{ [days/year]}} \times 100 \text{ [\%]} \approx 46.03\%$$

Set 46.03% to Pr. 899.



Calculate the annual power saving amount from Pr. 899 "Operation time rate (estimated value)" and power saving average value monitor:

$$\text{Annual power saving amount [kWh/year]} = \frac{\text{Power saving average value [kW] during totalization when Pr. 898 = 10 or 9999}}{\text{Pr. 899}} \times 24\text{h} \times 365 \text{ days}$$

The annual power saving amount charge can be monitored by setting the power charge per hour in Pr. 896 "Power unit cost". Calculate the annual power saving amount charge in the following method:

$$\text{Annual power saving amount charge} = \text{Annual power saving amount [kWh/year]} \times \text{Pr. 896}$$

**NOTE**

In the regeneration mode, make calculation on the assumption that "power saving = power during commercial power supply operation (input power = 0)".

## 6.19 Motor noise, noise reduction

### 6.19.1 PWM carrier frequency and Soft-PWM control (Pr. 72, Pr. 240, Pr. 260)

You can change the motor sound.

Pr. No.	Name	Initial Value	Setting Range	Description	Parameters referred to	Refer to Section	
72	PWM frequency selection ①	2	01800 or less	0–15 (integral value)	PWM carrier frequency can be changed. The setting displayed is in [kHz]. The settings indicate the following frequencies: 0 ..... 0.7kHz Settings between 1–14 correspond directly to the frequency values. 15 ..... 14.5kHz 25 ..... 2.5kHz	156 Stall prevention operation selection 570 Multiple rating setting	6.7.4 6.7.5
			02160 or more	0–6/25			
240	Soft-PWM operation selection ①	1	0	Soft-PWM is invalid			
			1	When Pr. 72 = 0 to 5 (0 to 4 for 01800 or more), Soft-PWM is valid.			
260	PWM frequency automatic switchover ①	1	0	PWM carrier frequency is constant independently of load. When the carrier frequency is set to 3kHz or more (Pr. 72 ≥ 3), perform continuous operation at less than 85% of the rated inverter current.			
			1	Decreases PWM carrier frequency automatically when load increases.			

- ① The above parameters allow its setting to be changed during operation in any operation mode even if "0" (initial value) is set in Pr. 77 "Parameter write selection".
- ② Reading and writing are enabled when "0 (SLD) or 1 (LD)" is set in Pr. 570.

#### PWM carrier frequency changing (Pr. 72)

You can change the PWM carrier frequency of the inverter.

Changing the PWM carrier frequency produces an effect on avoiding the resonance frequency of a mechanical system or motor or on reducing noise or leakage current generated from the inverter.

Carrier frequencies under real sensorless vector control or vector control are as shown below.

Pr. 72		Carrier Frequencies (kHz)
01800 or less	02160 or more	
0 to 5	0 to 5	2
6 to 9	6	6
10 to 3	—	10
14/15	—	14

**Tab. 6-102:** Carrier frequencies under real sensorless vector control or vector control

When using an option sine wave filter (MT-BSL/BSC) for the 02160 or more, set "25" in Pr. 72 (2.5kHz).

#### NOTE

When "25" (available with the 02160 or more) is set in Pr. 72, V/f control is forcibly selected.

**Soft-PWM control (Pr. 240)**

Soft-PWM control is a control system that changes the motor noise from a metallic tone into an unoffending complex tone.

**PWM carrier frequency automatic reduction function (Pr. 260)**

For PWM carrier frequency automatic reduction function, the following should be noted.

Multiple rating (Pr. 570)		PWM carrier frequency automatic reduction
0	120%	Valid
1	150%	Pr. 260 = 0: Invalid Pr. 260 = 1 (Initial value): Valid
2 (Initial value)	200%	Invalid
3	250%	Invalid

**Tab. 6-103:** PWM carrier frequency automatic reduction function

When continuous operation is performed at 85% or more of the inverter rated current (the parenthesized value of the rated output current on page 420 or more) with the carrier frequency of the inverter set to 3kHz or more (Pr. 72  $\geq$  "3"), the carrier frequency is automatically reduced to 2kHz to protect the output transistor of the inverter. (Motor noise increases, but it is not a failure)

When Pr. 260 is set to "0", the carrier frequency becomes constant (Pr. 72 setting) independently of the load, making the motor sound uniform.

Note that continuous operation should be performed at less than 85% of the inverter rating.

**NOTES**

Decreasing the PWM carrier frequency reduces inverter-generated noise and leakage current, but increases motor noise.

When PWM carrier frequency is set to 1kHz or less (Pr. 72  $\leq$  1), fast response current limit may function prior to stall prevention operation due to increase in ripple currents, resulting in insufficient torque. In such case, set fast-response current limit operation invalid using Pr. 156 "Stall prevention operation selection".

When connecting a sine wave output filter please observe the manufacturer's specifications for the necessary carrier frequency (the carrier frequency of the inverter).

## 6.20 Frequency/torque setting by analog input (terminals 1, 2 and 4)

Purpose	Parameters that must be set		Refer to Section
Function assignment of analog input terminal	Terminal 1 and terminal 4 function assignment	Pr. 858, Pr. 868	6.20.1
Selection of voltage/current input (terminal 1, 2, 4) Perform forward/reverse rotation by analog input.	Analog input selection	Pr. 73, Pr. 267	6.20.2
Adjust the main speed by analog auxiliary input	Analog auxiliary input and compensation (added compensation and override function)	Pr. 73, Pr. 242, Pr. 243, Pr. 252, Pr. 253	6.20.3
Noise elimination at the analog input	Input filter	Pr. 74, Pr. 822, Pr. 826, Pr. 832, Pr. 836, Pr. 849	6.20.4
Adjustment (calibration) of analog input frequency and voltage (current)	Bias and gain of frequency setting voltage (current)	Pr. 125, Pr. 126, Pr. 241, C2–C7 (Pr. 902–Pr. 905), C12–C15 (Pr. 917–Pr. 918)	6.20.5
Adjustment (calibration) of analog input torque and voltage (current)	Bias and gain of torque setting voltage (current)	Pr. 241, C16–C19 (Pr. 919–Pr. 920), C38–C41 (Pr. 932–Pr. 933)	6.20.6
Analog input (current) status check	4mA input check	Pr. 573	6.20.7

### 6.20.1 Function assignment of analog input terminal (Pr. 858, Pr. 868)

Function assignment of terminal 1 and terminal 4 of analog input can be selected and changed by parameter.

Pr. No.	Name	Initial Value	Setting Range	Description	Parameters referred to	Refer to Section
<b>858</b>	Terminal 4 function assignment	0	0/1/4/9999	Select the terminal 4 function (refer to Tab. 6-104)	Advanced magnetic flux vector control	6.7.2
<b>868</b>	Terminal 1 function assignment	0	0–6/9999	Select the terminal 1 function (refer to Tab. 6-105)	Real sensorless vector control	6.2.2
					804 Torque command source selection	6.4.5
					807 Speed limit selection	6.4.7
					810 Torque limit input method selection	6.3.2

For the terminal 1 and terminal 4 used for analog input, frequency (speed) command, magnetic flux command, torque command, etc. can be selected.

Functions change according to the control mode as shown in the tables on the next page.

Pr. 868	V/f Control, Advanced Magnetic Flux Vector Control	Real Sensorless Vector Control, Vector Control		Vektorregelung
		Speed control	Torque control	Position control
0 (Initial value)	Frequency setting auxiliary	Speed setting auxiliary	Speed setting auxiliary	—
1	—	Magnetic flux command	Magnetic flux command	Magnetic flux command
2	—	Regenerative torque limit (Pr. 810 = 1)	—	Regenerative torque limit (Pr. 810 = 1)
3	—	—	Torque command (Pr. 804 = 0)	—
4	Stall prevention operation level input (Pr. 810 = 1)	Torque limit (Pr. 810 = 1)	Torque command (Pr. 804 = 0)	Torque limit (Pr. 810 = 1)
5	—	—	Forward/reverse rotation speed limit (Pr. 807 = 2)	—
6	—	Torque bias input (Pr. 840 = 1, 2, 3)	—	—
9999	—	—	—	—

**Tab. 6-104:** Function of terminal 1 according to the control mode

Pr. 858	V/f Control, Advanced Magnetic Flux Vector Control	Real Sensorless Vector Control, Vector Control		Vektorregelung
		Speed control	Torque control	Position control
0 (Initial value)	Frequency command (AU signal-ON)	Speed command (AU signal-ON)	Speed limit (AU signal-ON)	—
1	—	Magnetic flux command	Magnetic flux command	Magnetic flux command
4	Stall prevention operation level input (Pr. 810 = 1)	Torque limit (Pr. 810 = 1)	—	Torque limit (Pr. 810 = 1)
9999	—	—	—	—

**Tab. 6-105:** Function of terminal 4 according to the control mode

#### NOTES

When "4" is set in both Pr. 868 and Pr. 858, terminal 1 is made valid and terminal 4 has no function

When "4" (stall prevention/torque limit) is set in Pr. 868, functions of terminal 4 become valid independently of whether the AU terminal is on or off.

## 6.20.2 Analog input selection (Pr. 73, Pr. 267)

You can select the function that switches between forward rotation and reverse rotation according to the analog input selection specifications, the override function and the input signal polarity.

The following settings are possible:

- Select reference voltages and currents: 0 to  $\pm 10V$ , 0 to  $\pm 5V$  or 0/4 to 20mA
- Select an arithmetical or percentage compensation
- Suppress motor reversing when there is a negative set point signal voltage at terminal 1

Pr. No.	Name	Initial Value	Setting Range	Voltage/current input switch	Description	Parameters referred to	Refer to Section	
73	Analog input selection	1	0 to 5, 10 to 15	Switch 2 - OFF (initial status)	You can select the input specifications of terminal 2 (0 to 5V, 0 to 10V, 0 to 20mA) and input specifications of terminal 1 (0 to $\pm 5V$ , 0 to $\pm 10V$ ). Override and reversible operation can be selected.	22	Stall prevention operation level	6.7.4
			6/7/16/17	Switch 2 - ON		125	Terminal 2 frequency setting gain frequency	6.20.5
267	Terminal 4 input selection	0	0	Switch 1 - ON (initial status)	Terminal 4 input 4 to 20mA	126	Terminal 4 frequency setting gain frequency	6.20.5
			1	Switch 1 - OFF	Terminal 4 input 0 to 5V	252	Override bias	6.20.3
			2		Terminal 4 input 0 to 10V	253	Override gain	6.20.3
					858	Terminal 4 function assignment	6.20.1	
						868	Terminal 1 function assignment	6.20.1

**Selection of analog input specifications**

For the terminals 2, 4 used for analog input, voltage input (0 to 5V, 0 to 10V) or current input (0 to 20mA) can be selected.

Change parameters (Pr.73, Pr.267) and a voltage/current input switch (switch 1, 2) to change input specifications.

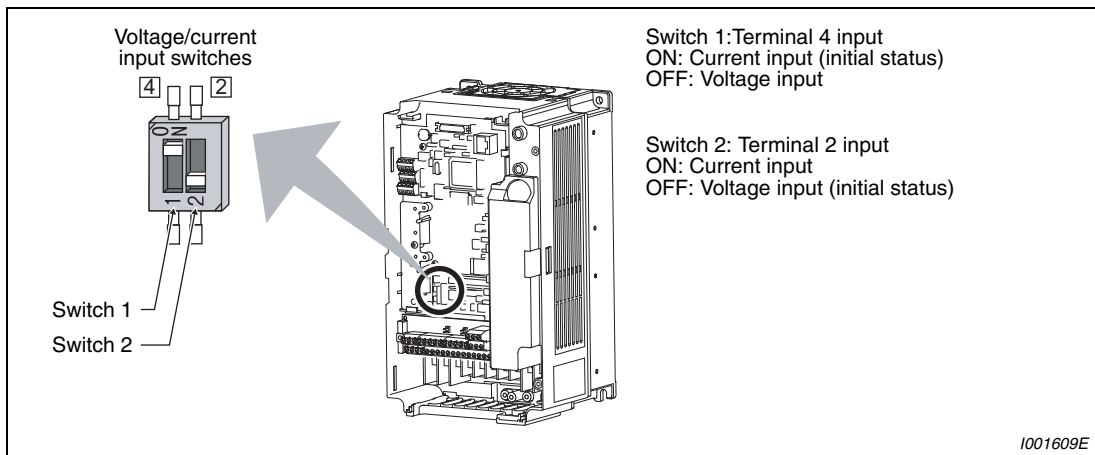

**Fig. 6-177: Voltage/current input switches**

Rated specifications of terminal 2 and 4 change according to the voltage/current input switch setting.

- Voltage input: Input resistance  $10k\Omega \pm 1k\Omega$ , Maximum permissible voltage 20VDC
- Current input: Input resistance  $245\Omega \pm 5\Omega$ , Maximum permissible current 30mA



**CAUTION:**  
Set Pr. 73, Pr. 267, and a voltage/current input switch correctly, then input an analog signal in accordance with the setting. Incorrect setting as in the table below may result in failure. Incorrect settings other than below can cause abnormal operation.

Setting Causing Failure		Operation
Switch setting	Terminal input	
ON (Current input)	Voltage input	This could lead to damage to the analog signal output circuit of external devices. (electrical load in the analog signal output circuit of external devices increases)
OFF (Voltage input)	Current input	This could lead to damage to the input circuit of the inverter. (output power in the analog signal output circuit of external devices increases)

Refer to the following table and set Pr. 73 and Pr. 267. The half-tone screened areas indicate the main speed setting. The other inputs are used for compensation.

Pr. 73	AU Signal	Terminal 2 Input	Terminal 1 Input	Terminal 4 Input	Compensation Input Terminal and Compensation Method	Polarity Reversible
0	OFF	0 to 10V	0 to ±10V	—	Terminal 1 Added compensation	No ①
1 (initial value)		0 to 5V	0 to ±10V			
2		0 to 10V	0 to ±5V			
3		0 to 5V	0 to ±5V			
4		0 to 10V	0 to ±10V		Terminal 2 Override	
5		0 to 5V	0 to ±5V			
6		0/4 to 20mA	0 to ±10V		Terminal 1 Added compensation	
7		0/4 to 20mA	0 to ±5V			
10		0 to 10V	0 to ±10V			
11		0 to 5V	0 to ±10V			
12		0 to 10V	0 to ±5V			
13		0 to 5V	0 to ±5V			
14		0 to 10V	0 to ±10V		Terminal 2 Override	
15		0 to 5V	0 to ±5V			
16		0/4 to 20mA	0 to ±10V		Terminal 1 Added compensation	
17		0/4 to 20 mA	0 to ±5V			
0		ON	—		0 to ±10V	According to Pr. 267 set- ting: 0: 4 to 20mA (initial value) 1: 0 to 5V 2: 0 to 10V
1	0 to ±10V					
2	0 to ±5V					
3	0 to ±5V					
4	0 to 10V		—	Terminal 2 Override		
5	0 to 5V					
6	—		0 to ±10V	Terminal 1 Added compensation		
7			0 to ±5V			
10			0 to ±10V			
11			0 to ±10V			
12	—		0 to ±5V	Terminal 2 Override		
13			0 to ±5V			
14	0 to 10V		—			
15	0 to 5V					
16	—		0 to ±10V	Terminal 1 Added compensation		
17			0 to ±5V			

Tab. 6-106: Setting of parameter 73 and 267

① Indicates that a frequency command signal of negative polarity is not accepted.



Set the voltage/current input switch referring to the table below.

Terminal 2 Input Specifications	Pr. 73 Setting	Switch 2
Voltage input (0 to 10V)	0/2/4/10/12/14	OFF
Voltage input (0 to 5V) <sup>①</sup>	1 (initial value)/3/5/11/13/15	OFF
Stromeingang (0–20 mA)	6/7/16/17	ON
Terminal 4 Input Specifications	Pr. 267 Setting	Switch 1
Voltage input (0 to 10V)	2	OFF
Voltage input (0 to 5V)	1	OFF
Stromeingang (0–20 mA) <sup>①</sup>	0 (initial value)	ON

**Tab. 6-107:** Settings for the voltage/current input switches

<sup>①</sup> Initial value

## NOTES

Turn the AU signal on to make terminal 4 valid.

Match the setting of parameter and switch. A different setting may cause a fault, failure or malfunction.

The terminal 1 (frequency setting auxiliary input) signal is added to the main speed setting signal of the terminal 2 or 4.

When an override is selected, the terminal 1 or 4 is used for the main speed setting and the terminal 2 for the override signal (50% to 150% at 0 to 5V or 0 to 10V). (When the main speed of the terminal 1 or terminal 4 is not input, compensation by the terminal 2 is made invalid.)

Use Pr. 125 (Pr. 126) (frequency setting gain) to change the maximum output frequency at input of the maximum output frequency command voltage (current). At this time, the command voltage (current) need not be input. Also, the acceleration/deceleration time, which is a slope up/down to the acceleration/deceleration reference frequency, is not affected by the change in Pr. 73 setting.

When Pr. 858 "Terminal 4 function assignment", Pr. 868 "Terminal 1 function assignment" = "4", the value of the terminal 1 or terminal 4 is as set to the stall prevention operation level. When terminal 1 and terminal 4 are used for frequency setting, set "0" (initial value) in Pr. 858 and Pr. 868.

**Perform operation by analog input voltage**

The frequency setting signal inputs 0 to 5V DC (or 0 to 10V DC) to across the terminals 2-5. The 5V (10V) input is the maximum output frequency. The maximum output frequency is reached when 5V (10V) is input.

The power supply 5V (10V) can be input by either using the internal power supply or preparing an external power supply. The internal power supply outputs 5V DC across terminals 10-5, or 10V across terminals 10E-5.

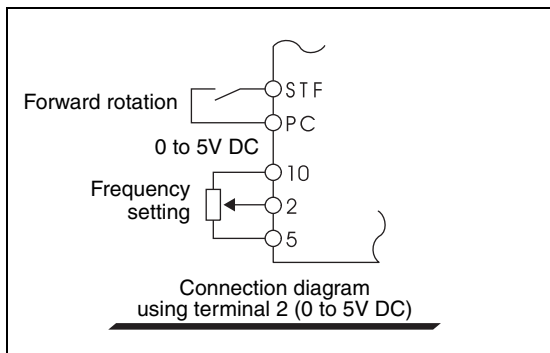

**Fig. 6-178:**  
Frequency setting by voltage 0 to 5V DC

I001182E

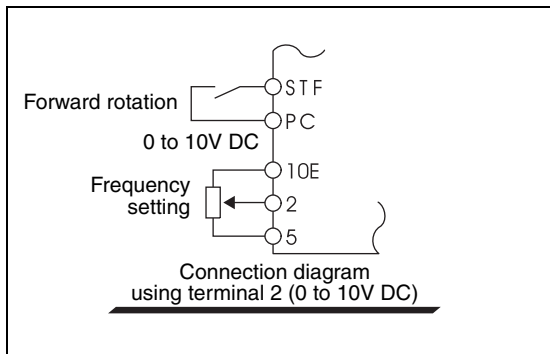

**Fig. 6-179:**  
Frequency setting by voltage 0 to 10V DC

I001183E

Terminal	Inverter Built-in Power Supply Voltage	Frequency Setting Resolution	Pr. 73 (terminal 2 input voltage)
10	5V DC	0.024/50Hz	0 to 5V DC
10E	10V DC	0.012/50Hz	0 to 10V DC

**Tab. 6-108:** Built-in power supply voltage

When inputting 10V DC to the terminal 2, set any of "0, 2, 4, 10, 12, 14" in Pr. 73. (The initial value is 0 to 5V.)

Setting "1" (0 to 5V DC) or "2" (0 to 10V DC) in Pr. 267 changes the terminal 4 to the voltage input specification. When the AU signal turns on, the terminal 4 input becomes valid.

**NOTE**

The wiring length of the terminals 10, 2, and 5 should be 30m maximum.

**Perform operation by analog input current**

When the pressure or temperature is controlled constant by a fan, pump, etc., automatic operation can be performed by inputting the output signal 0/4 to 20mA of the adjuster to across the terminals 4-5.

The AU signal must be turned on to use the terminal 4.

Setting any of "6, 7, 16, 17" in Pr. 73 changes the terminal 2 to the current input specification. At this time, the AU signal need not be turned on.

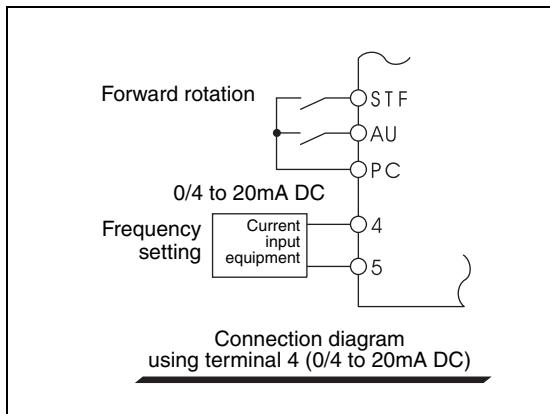

**Fig. 6-180:**  
Frequency setting by the function "Current input 0/4 to 20mA" assigned to terminal 4

1001184E

**Perform forward/reverse rotation by analog input (polarity reversible operation)**

Setting any of "10 to 17" in Pr. 73 enables polarity reversible operation.

Providing ± input (0 to ±5V or 0 to ±10V) to the terminal 1 enables forward/reverse rotation operation according to the polarity.

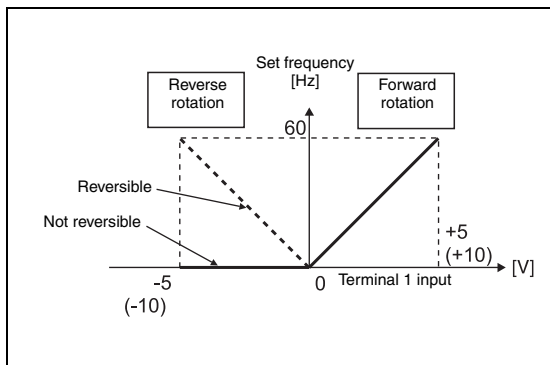

**Fig. 6-181:**  
Compensation input characteristic when STF is on

1001185E

### 6.20.3 Analog input compensation (Pr. 73, Pr. 242, Pr. 243, Pr. 252, Pr. 253)

A fixed ratio of analog compensation (override) can be made by the added compensation or terminal 2 as an auxiliary input for multi-speed operation or the speed setting signal (main speed) of the terminal 2 or terminal 4.

Pr. No.	Name	Initial Value	Setting Range	Description
73	Analog input selection	1	0-3/6/7/ 10-13/ 16/17	Added compensation
			4/5/14/15	Override compensation
242	Terminal 1 added compensation amount (terminal 2)	100%	0-100%	Set the ratio of added compensation amount when terminal 2 is the main speed.
243	Terminal 1 added compensation amount (terminal 4)	75%	0-100%	Set the ratio of added compensation amount when terminal 4 is the main speed.
252	Override bias	50%	0-200%	Set the bias side compensation value of override function.
253	Override gain	150%	0-200%	Set the gain side compensation value of override function.

Parameters referred to	Refer to Section
28 Multi-speed input compensation selection	6.10.3
73 Analog input selection	6.20.2

#### Added compensation (Pr. 242, Pr. 243)

A compensation signal can be input to the main speed setting for synchronous/continuous speed control operation, etc.

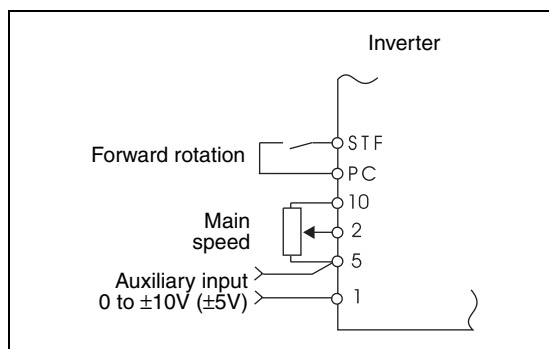

**Fig. 6-182:**  
Added compensation connection example

1001186E

Setting any of "0 to 3, 6, 7, 10 to 13, 16, 17" in Pr. 73 adds the voltage across terminals 1-5 to the voltage signal across terminals 2-5.

If the result of addition is negative, it is regarded as "0" at the Pr. 73 setting of any of "0 to 3, 6, 7", or reverse rotation operation (polarity reversible operation) is performed when the STF signal turns on at the Pr. 73 setting of any of "10 to 13, 16, 17".

The compensation input of the terminal 1 can also be added to the multi-speed setting or terminal 4 (initial value 0/4 to 20mA).

The added compensation for terminal 2 can be adjusted by Pr. 242, and the compensation for terminal 4 by Pr. 243:

$$\text{Analog command value using terminal 2} = \text{Terminal 2 input} + \text{Terminal 1 input} \times \frac{\text{Pr. 242}}{100 [\%]}$$

$$\text{Analog command value using terminal 4} = \text{Terminal 4 input} + \text{Terminal 1 input} \times \frac{\text{Pr. 243}}{100 [\%]}$$

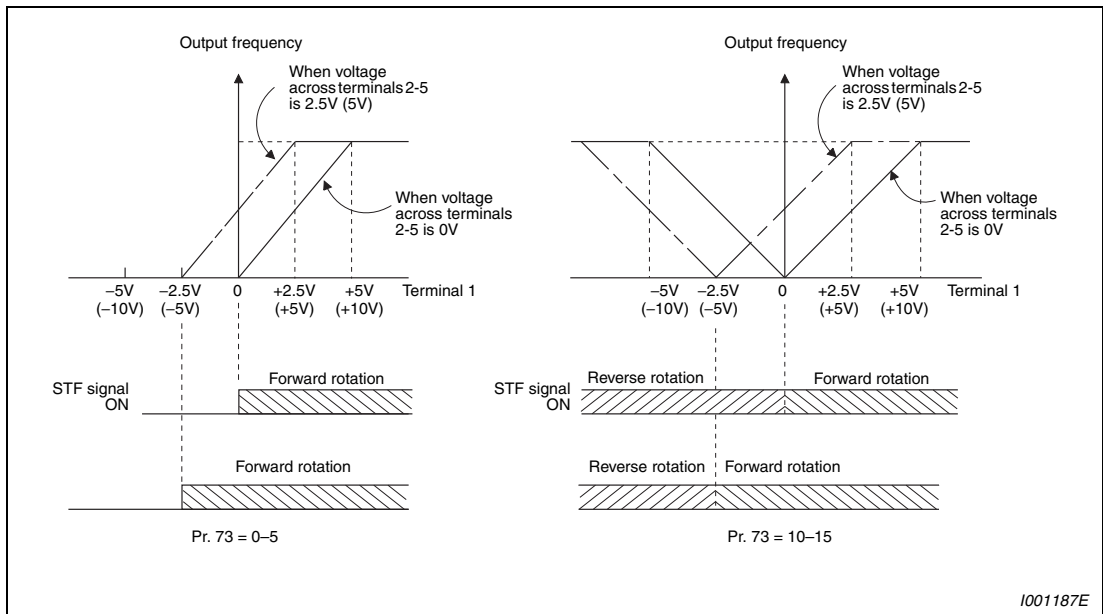

**Fig. 6-183:** Auxiliary input characteristics

**NOTE**

When the Pr. 73 setting was changed, check the voltage/current input switch setting. Different setting may cause a fault, failure or malfunction. (Refer to page 6-375 for setting.)

**Override function (Pr. 252, Pr. 253)**

Use the override function to change the main speed at a fixed ratio.

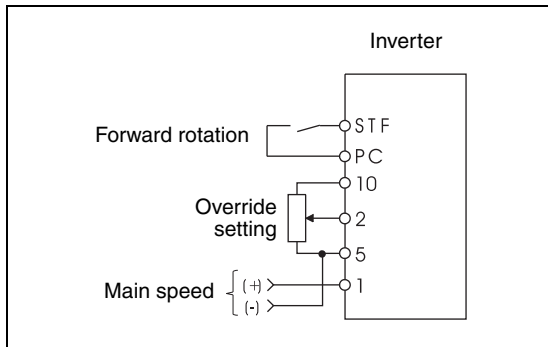

**Fig. 6-184:** Override connection diagram

Set any of "4, 5, 14, 15" in Pr. 73 to select an override.

When an override is selected, the terminal 1 or terminal 4 is used for the main speed setting and the terminal 2 for the override signal. (When the main speed of the terminal 1 or terminal 4 is not input, compensation made by the terminal 2 becomes invalid.)

Using Pr. 252 and Pr. 253, set the override range.

How to find the set frequency for override:

$$\text{Set frequency [Hz]} = \text{Main speed set frequency [Hz]} \times \frac{\text{Compensation amount [\%]}}{100 [\%]}$$

Main speed set frequency [Hz]: Terminal 1, 4 or multi-speed setting

Compensation amount [%]: Terminal 2 input

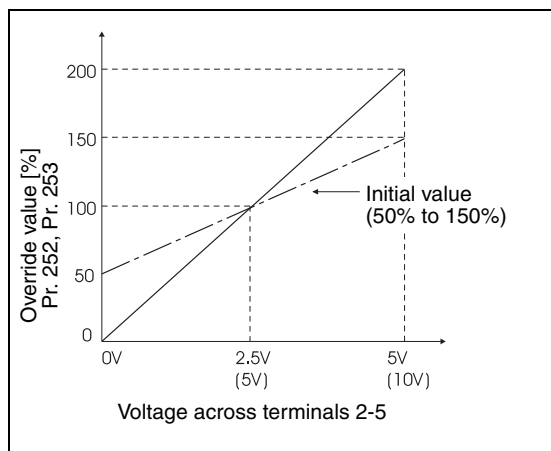

**Fig. 6-185:**  
Override

I001189E

**Example** ▽

Pr. 73 = 5

The set frequency changes as shown below according to the terminal 1 (main speed) and terminal 2 (auxiliary) inputs.

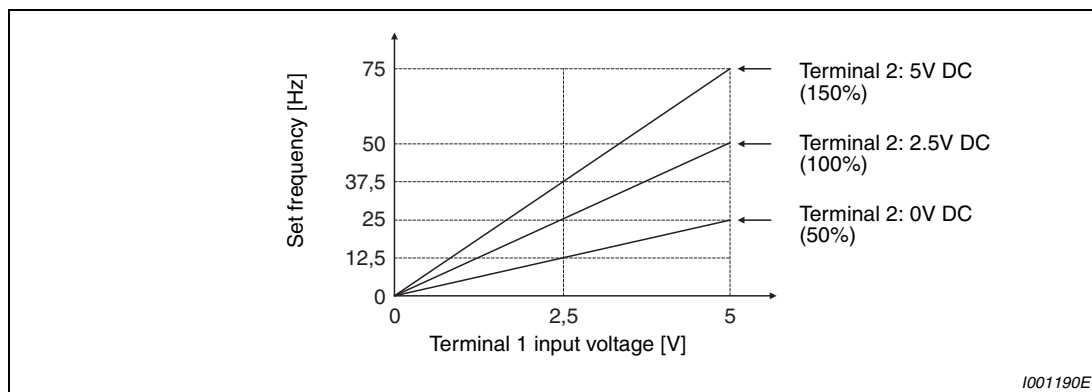

I001190E

**Fig. 6-186:** Set frequency in dependence on the terminal 1 and terminal 2 signals



**NOTES**

When the Pr. 73 setting was changed, check the voltage/current input switch setting. Different setting may cause a fault, failure or malfunction. (Refer to page 6-375 for setting.)

The AU signal must be turned on to use the terminal 4.

When inputting compensation to multi-speed operation or remote setting, set "1" (compensation made) to Pr. 28 "Multi-speed input compensation selection". (Initial value is "0".)

## 6.20.4 Response level of analog input and noise elimination (Pr. 74, Pr. 822, Pr. 826, Pr. 832, Pr. 836, Pr. 849)

Response level and stability of frequency reference command and torque reference command by analog input (terminal 1, 2, 4) signal can be adjusted.

Pr. No.	Name	Initial Value	Setting Value	Description
<b>74</b>	Input filter time constant	1	0–8	Set the primary delay filter time constant for the analog input. A larger setting results in a larger filter.
<b>822</b>	Speed setting filter 1	9999	0–5s	Set the time constant of the primary delay filter relative to the external speed command (analog input command).
			9999	Pr. 74 used
<b>826</b>	Torque setting filter 1	9999	0–5s	Set the time constant of the primary delay filter relative to the external torque command (analog input command).
			9999	Pr. 74 used
<b>832</b>	Speed setting filter 2	9999	0–5s/9999	Second function of Pr. 822 (valid when RT terminal is on)
<b>836</b>	Torque setting filter 2	9999	0–5s/9999	Second function of Pr. 826 (valid when RT terminal is on)
<b>849</b>	Analog input offset adjustment	100%	0–200%	This function provides speed command by analog input (terminal 2) with offset. Motor rotation due to noise, etc. by analog input can be avoided at zero speed command.

Parameters referred to	Refer to Section
73 Analog input selection	6.20.2
125 Bias and gain of the terminal 2 frequency setting C2–C4	6.20.5

### Time constant of analog input (Pr. 74)

Effective for eliminating noise in the frequency setting circuit. Increase the filter time constant if steady operation cannot be performed due to noise.

A larger setting results in slower response (The time constant can be set between approximately 10ms to 1s with the setting of 0 to 8).

### Time constant of analog speed command input (Pr. 822, Pr. 832)

Set the time constant of the primary delay filter relative to the external torque command (analog input command) using Pr. 822 "Speed setting filter 1".

Set a large time constant when you want to delay the tracking of the speed command, when the analog input voltage fluctuates, etc.

When you want to change time constant when switching two motors with one inverter, use the Pr. 832 "Speed setting filter 2".

Pr. 832 "Speed setting filter 2" is made valid when the RT signal turns on.

**Time constant of analog torque command input (Pr. 826, Pr. 836)**

Set the time constant of the primary delay filter relative to the external torque command (analog input command) using Pr. 826 "Torque setting filter 1".

Set a large time constant value when you want to delay the tracking of the torque command, when the analog input voltage fluctuates, etc.

When you want to change time constant when switching two motors with one inverter, etc., use Pr. 836 "Torque setting filter 2".

Pr. 836 "Torque setting filter 2" is made valid when the RT signal turns on.

**Offset adjustment of analog speed command input (Pr. 849)**

When speed command by analog input is set, create the range where the motor remains stop to prevent malfunction at very low speed.

On the assumption that the Pr. 849 setting 100% as 0, the offset voltage is offset as follows:

100% < Pr. 849 .....positive side

100% > Pr. 849 .....negative side

The offset voltage is found by the following formula:

$$\text{Offset voltage [V]} = \frac{\text{Voltage at 100 \%}}{(5 \text{ or } 10 \text{ V} \text{ } \textsuperscript{\textcircled{1}})} \times \frac{\text{Pr. 849} - 100}{100}$$

① According to the Pr. 73 setting

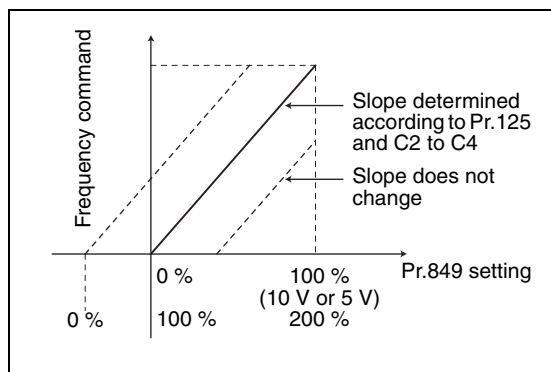

**Fig. 6-187:**  
Offset-Einstellung

I001611E



## 6.20.5 Bias and gain of frequency setting voltage (current) [Pr. 125, Pr. 126, Pr. 241, C2 (Pr. 902) to C7 (Pr. 905), C12 (Pr. 917) bis C15 (Pr. 918)]

You can set the magnitude (slope) of the output frequency as desired in relation to the frequency setting signal (0 to 5V, 0 to 10V or 0/4 to 20mA DC).

These parameters can be used to configure the inverter precisely for set point signals that either exceed or do not quite reach 5V or 10V or 20mA. These settings can also be used to configure inverse control (i.e. high output frequency at minimum set point signal, minimum output frequency at maximum set point signal).

Pr. No.	Name	Initial Value	Setting Range	Description	Parameters referred to	Refer to Section	
<b>125</b>	Terminal 2 frequency setting gain frequency	50Hz	0–400Hz	Set the frequency of terminal 2 input gain (maximum).	20 Acceleration/ deceleration reference frequency 73 Analog input selection 267 Terminal 4 input selection 79 Operation mode selection	6.11.1 6.20.2 6.20.2 6.22.1	
<b>126</b>	Terminal 4 frequency setting gain frequency	50Hz	0–400Hz	Set the frequency of terminal 4 input gain (maximum).			
<b>241</b>	Analog input display unit switchover <sup>②</sup>	0	0	Displayed in %			Select the unit of analog input display.
			1	Displayed in V/mA			
<b>C2 (902)</b>	Terminal 2 frequency setting bias frequency <sup>①</sup>	0Hz	0–400Hz	Set the frequency on the bias side of terminal 2 input.			
<b>C3 (902)</b>	Terminal 2 frequency setting bias <sup>①</sup>	0%	0–300%	Set the converted % of the bias side voltage (current) of terminal 2 input.			
<b>C4 (903)</b>	Terminal 2 frequency setting gain <sup>①</sup>	100%	0–300%	Set the converted % of the gain side voltage of terminal 2 input.			
<b>C5 (904)</b>	Terminal 4 frequency setting bias frequency <sup>①</sup>	0Hz	0–400Hz	Set the frequency on the bias side of terminal 4 input.			
<b>C6 (904)</b>	Terminal 4 frequency setting bias <sup>①</sup>	20%	0–300%	Set the converted % of the bias side current (voltage) of terminal 4 input.			
<b>C7 (905)</b>	Terminal 4 frequency setting gain <sup>①</sup>	100 %	0–300 %	Set the converted % of the gain side current (voltage) of terminal 4 input.			
<b>C12 (917)</b>	Terminal 1 bias frequency (speed) <sup>①</sup>	0 Hz	0–400 Hz	Set the frequency (speed) on the bias side of terminal 1 input.			
<b>C13 (917)</b>	Terminal 1 bias (speed) <sup>①</sup>	0 %	0–300 %	Set the converted % of the bias side voltage of terminal 1 input.			
<b>C14 (918)</b>	Terminal 1 gain frequency (speed) <sup>①</sup>	50 Hz	0–400 Hz	Set the frequency (speed) of terminal 1 input gain (maximum).			
<b>C15 (918)</b>	Terminal 1 gain (speed) <sup>①</sup>	100 %	0–300 %	Set the converted % of the gain side voltage of terminal 1 input.			

① The parameter number in parentheses is the one for use with the parameter unit (FR-PU04 or FR-PU07).

② The above parameter allow its setting to be changed during operation in any operation mode even if "0" (initial value) is set in Pr. 77 "Parameter write selection".

Relationship between analog input terminal and calibration parameter

Pr. 868 Setting	Terminal Function	Calibration Parameters			
		Bias setting		Gain setting	
0 (Initial value)	Frequency (speed) setting auxiliary	C2 (Pr. 902)	Terminal 2 frequency setting bias frequency	Pr. 125	Terminal 2 frequency setting gain frequency
		C3 (Pr. 902)	Terminal 2 frequency setting bias	C4 (Pr. 903)	Terminal 2 frequency setting gain
		C5 (Pr. 904)	Terminal 4 frequency setting bias frequency	Pr. 126	Terminal 4 frequency setting gain frequency
		C6 (Pr. 904)	Terminal 4 frequency setting bias	C7 (Pr. 905)	Terminal 4 frequency setting gain
1	Magnetic flux command	C16 (Pr. 919)	Terminal 1 bias command (torque/magnetic flux)	C18 (Pr. 920)	Terminal 1 gain command (torque/magnetic flux)
		C17 (Pr. 919)	Terminal 1 bias (torque/magnetic flux)	C19 (Pr. 920)	Terminal 1 gain (torque/magnetic flux)
2	Regenerative torque limit				
3	Torque command	C16 (Pr. 919)	Terminal 1 bias command (torque/magnetic flux)	C18 (Pr. 920)	Terminal 1 gain command (torque/magnetic flux)
4	Stall prevention operation level <sup>①</sup> /torque limit/torque command	C17 (Pr. 919)	Terminal 1 bias (torque/magnetic flux)	C19 (Pr. 920)	Terminal 1 gain (torque/magnetic flux)
5	Forward/reverse rotation speed limit	C12 (Pr. 917)	Terminal 1 bias frequency (speed)	C14 (Pr. 918)	Terminal 1 gain frequency (speed)
		C13 (Pr. 917)	Terminal 1 bias (speed)	C15 (Pr. 918)	Terminal 1 gain (speed)
6	Torque bias input	C16 (Pr. 919)	Terminal 1 bias command (torque/magnetic flux)	C18 (Pr. 920)	Terminal 1 gain command (torque/magnetic flux)
		C17 (Pr. 919)	Terminal 1 bias (torque/magnetic flux)	C19 (Pr. 920)	Terminal 1 gain (torque/magnetic flux)
9999	—	—	—	—	—

**Tab. 6-109:** Terminal 1 functional calibration parameter

- <sup>①</sup> Use Pr. 148 "Stall prevention level at 0V input" and Pr. 149 "Stall prevention level at 10V" input to adjust bias/gain of stall prevention operation level.

Pr. 858 Setting	Terminal Function	Calibration Parameters			
		Bias setting		Gain setting	
0 (Initial value)	Frequency command/ speed command	C5 (Pr. 904)	Terminal 4 frequency setting bias frequency	Pr. 126	Terminal 4 frequency setting gain frequency
		C6 (Pr. 904)	Terminal 4 frequency setting bias	C7 (Pr. 905)	Terminal 4 frequency setting gain
1	Magnetic flux command	C38 (Pr. 932)	Terminal 4 bias command (torque/magnetic flux)	C40 (Pr. 933)	Terminal 4 gain command (torque/magnetic flux)
4	Stall prevention operation level <sup>①</sup> /torque limit	C39 (Pr. 932)	Terminal 4 bias (torque/magnetic flux)	C41 (Pr. 933)	Terminal 4 gain (torque/magnetic flux)
9999	—	—	—	—	—

**Tab. 6-110:** Terminal 4 functional calibration parameter

- ① Use Pr. 148 "Stall prevention level at 0V input" and Pr. 149 "Stall prevention level at 10V input" to adjust bias/gain of stall prevention operation level.

**Change the frequency at maximum analog input (Pr. 125, Pr. 126)**

Set a value to Pr. 125 (Pr. 126) when changing only the frequency setting (gain) of the maximum analog input power (current). (C2 (Pr. 902) to C7 (Pr. 905) setting need not be changed.)

**Analog input bias/gain calibration [C2 (Pr. 902) to C7 (Pr. 905), C12 (Pr. 917) to C15 (Pr.918)]**

The "bias" and "gain" functions are used to adjust the relationship between the input signal entered from outside the inverter to set the output frequency, e.g. 0 to 5V, 0 to 10V or 4 to 20mA DC, and the output frequency.)

Set the bias frequency of the terminal 2 input using C2 (Pr. 902). (factory-set to the frequency at 0V)

Parameter C3 (Pr. 902) is the frequency setting bias for the input signal at terminal 2, i.e. the minimum value of the analog signal. When signals are smaller than this value the frequency set point signal will be limited to the value set with C2.

Parameter 125 sets the gain for the terminal 2 output frequency. This is the frequency set point value that corresponds to the maximum analog signal defined with Pr. 73. (Pr. 125 is set to a default value of 50Hz at the factory.)

Parameter C4 (Pr. 903) sets the gain for the input signal on terminal 2, i.e. the maximum value of the analog signal connected to terminal 2. When signals exceed this value the frequency set point value is limited to the value stored in Pr. 125.

Parameter C5 (Pr. 904) sets the frequency set point bias frequency for terminal 4. This is the frequency corresponding to the minimum analog signal. (This parameter is set to a default value of 0Hz at the factory.)

Parameter C6 (Pr. 904) sets the bias of the input signal on terminal 4, i.e. the minimum value of the analog signal connected to terminal 4. When the signal on this terminal is lower than this value the frequency set point value is limited to the value set with C5. (This parameter is set to a default value of 20% at the factory, which corresponds to approx. 4mA.)

Parameter 126 sets the gain for the terminal 4 output frequency. This is the frequency set point value that corresponds to the maximum analog signal defined with Pr. 73. (Pr. 126 is set to a default value of 50Hz at the factory.)

Parameter C7 (Pr. 905) sets the gain of the input signal on terminal 4, i.e. the maximum value of the analog signal connected to terminal 4. When the signal on this terminal is higher than this value the frequency set point value is limited to the value set with Pr. 126.

Set the bias frequency of the terminal 1 input using C12 (Pr. 917). (factory-set to the frequency at 0V)

Parameter C13 (Pr. 917) sets the bias of the input signal on terminal 1, i.e. the minimum value of the analog signal connected to terminal 1. When the signal on this terminal is lower than this value the frequency set point value is limited to the value set with C15.

Set the gain frequency of the terminal 1 input using C14 (Pr. 918). (factory-set to the frequency at 10V)

Parameter C15 (Pr. 918) sets the gain for the input signal on terminal 1, i.e. the maximum value of the analog signal connected to terminal 1. When signals exceed this value the frequency set point value is limited to the value stored in Pr. C14 (Pr. 918).

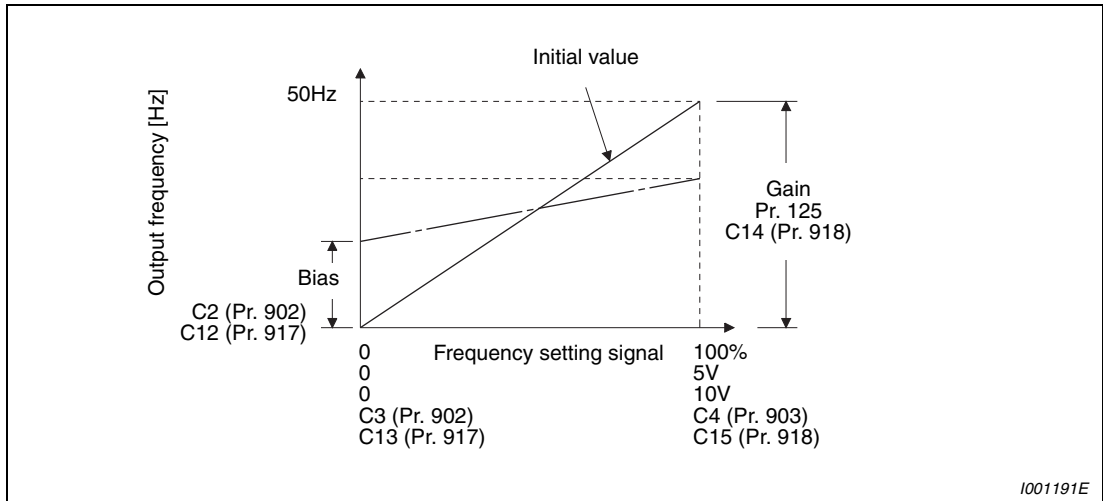

**Fig. 6-188:** Signal adjustment of terminal 2

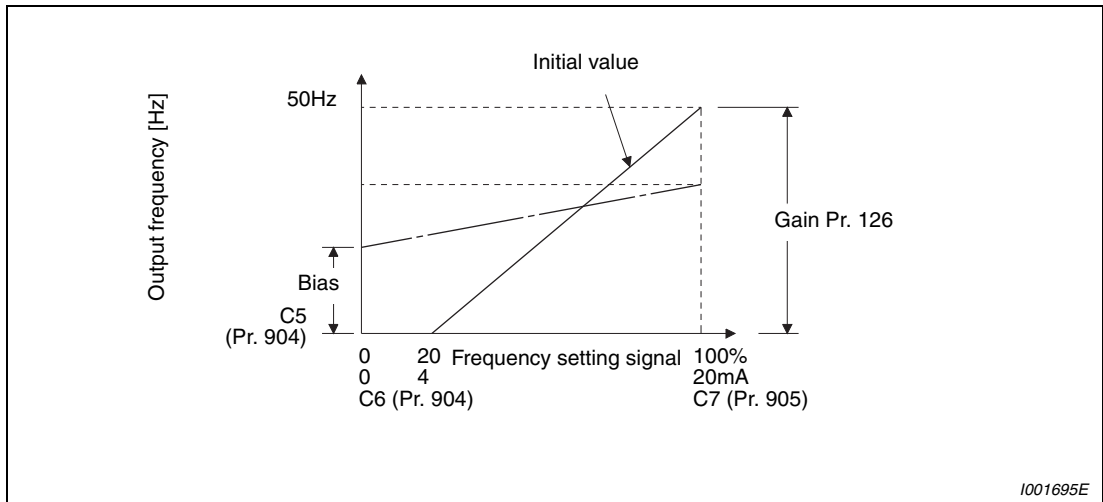

**Fig. 6-189:** Signal adjustment of terminal 4

There are three methods to adjust the frequency setting voltage (current) bias/gain:

- Method to adjust any point by application of voltage (current) to across the terminals 2-5 (4-5). (Refer to page 6-391.)
- Method to adjust any point without application of a voltage (current) to across terminals 2-5 (4-5). (Refer to page 6-392.)
- Adjusting only the frequency without adjusting the voltage (current). (Refer to page 6-393.)

**NOTES**

- When the terminal 2 is calibrated to change the inclination of the set frequency, the setting of the terminal 1 is also changed.
- When a voltage is input to the terminal 1 to make calibration, (terminal 2 (4) analog value + terminal 1 analog value) is the analog calibration value.
- When the voltage/current input specifications were changed using Pr. 73 and Pr. 267, be sure to make calibration.

**Analog input display unit changing (Pr. 241)**

The level display for the analog signal connected to terminal 2 or terminal 4 can be switched between a % display and a display in V or mA.

Depending on the terminal input specification set to Pr. 73, Pr. 267 and voltage/current input switch, the display units of C3 (Pr. 902), C4 (Pr. 903), C6 (Pr. 904) C7 (Pr. 905) change as shown below.

Analog Command (terminal 2, 4) (according to Pr. 73, Pr. 267, voltage/current input switch)	Pr. 241 = 0 (initial value)	Pr. 241 = 1
0 to 5V input	0 to 5V → 0 to 100% (0.1%) is displayed.	0 to 100% → 0 to 5V (0.01V) is displayed.
0 to 10V input	0 to 10V → 0 to 100% (0.1%) is displayed.	0 to 100% → 0 to 10V (0.01V) is displayed.
0/4 to 20mA input	0 to 20mA → 0 to 100% (0.1%) is displayed.	0 to 100% → 0 to 20mA (0.01mA) is displayed.

**Tab. 6-111:** Units when displaying the set value

Note that the LEDs V or A also light up as an additional indicator when Pr. 241 is set to "1" and the display is set to the settings for C3/C4, C6/C7 or C13/C15.

**NOTES**

Analog input display is not displayed correctly if voltage is applied to terminal 1 when terminal 1 input specifications (0 to ±5V, 0 to ±10V) and main speed (terminal 2, terminal 4 input) specifications (0 to 5V, 0 to 10V, 0 to 20mA) differ. (For example, 5V (100%) is analog displayed when 0V and 10V are applied to terminal 2 and terminal 1 respectively in the initial status.

Set "0" (initial value is 0% display) in Pr. 241 to use.

### Frequency setting signal (current) bias/gain adjustment method

1. Method to adjust any point by application of voltage (current) to across the terminals 2-5 (4-5). The following example illustrating the procedure assumes that Pr. 241 is set to "0":

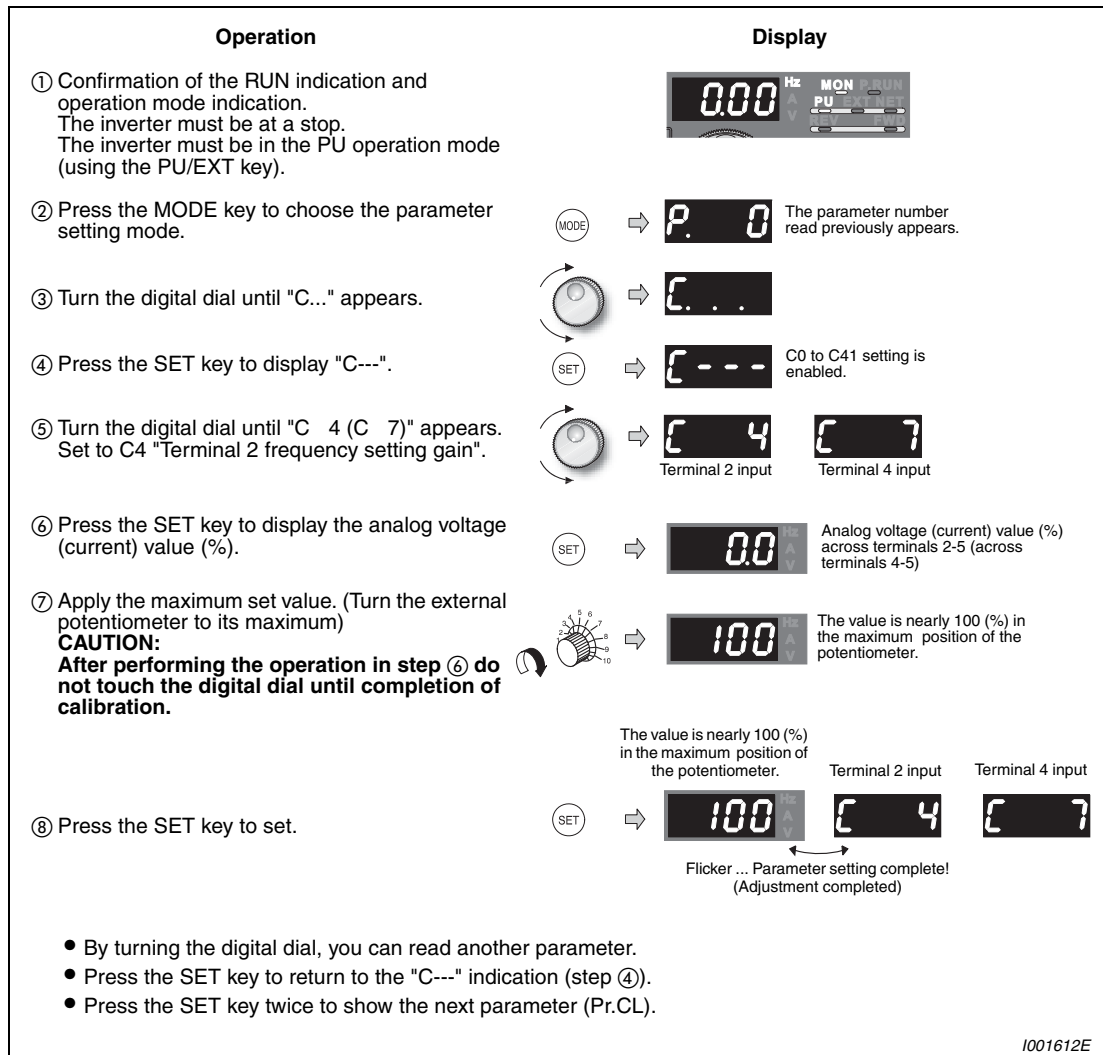

**Fig. 6-190:** Bias and gain adjustment by application of a reference signal

#### NOTES

If the frequency meter (indicator) connected to across terminals CA-PC does not indicate just 50Hz, set calibration parameter C0 "CA terminal calibration". (Refer to section 6.15.4)

Error code Er3 may be displayed when you save if the frequency values for gain and bias are less than approx. 5% apart. If this happens correct the frequency settings and save again.

If you try to set Pr. 125/126, C2 to C7 and C12 to C15 in external mode (EXT LED is on) error code Er4 will be displayed when you save. If this happens switch to PU mode and repeat the setting procedure, then save your settings.

If you try to set Pr. 125/126, C2 to C7 and C12 to C15 while the motor is being operated by the inverter error code Er2 will be displayed. If this happens stop the inverter, repeat the setting procedure and save your settings.

2. Method to adjust any point without application of a voltage (current) to across terminals 2-5 (4-5). (This example shows how to change from 4V to 5V, assuming that Pr. 241 is set to "1".)

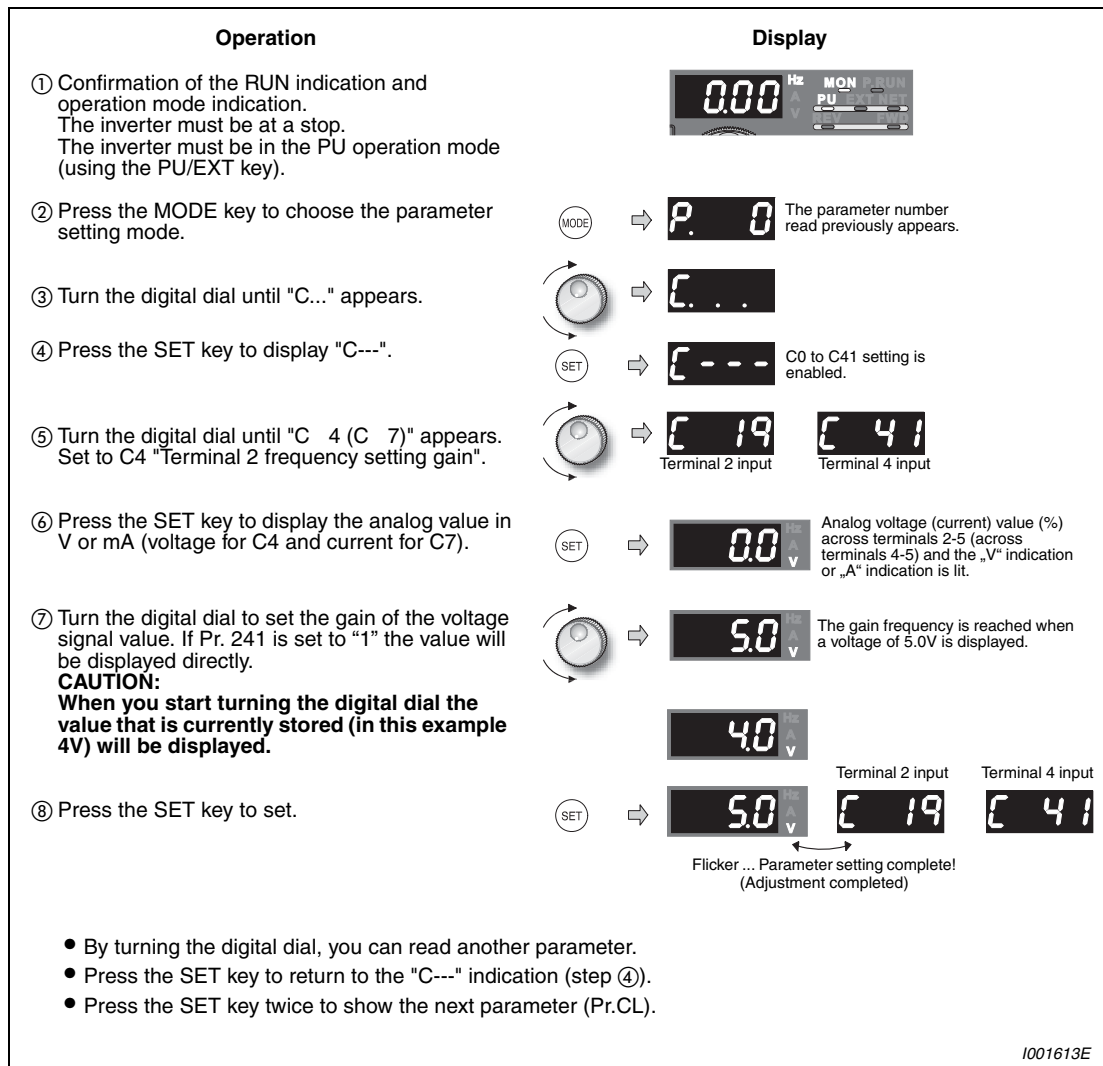

**Fig. 6-191:** Bias and gain adjustment without application of an reference signal

**NOTE**

By pressing the digital dial after step ⑥, you can confirm the current frequency setting bias/gain setting. It cannot be confirmed after execution of step ⑦.



3.Method to adjust only the frequency without adjustment of a gain voltage (current).  
 (The gain frequency is changed from 50Hz to 40Hz.)

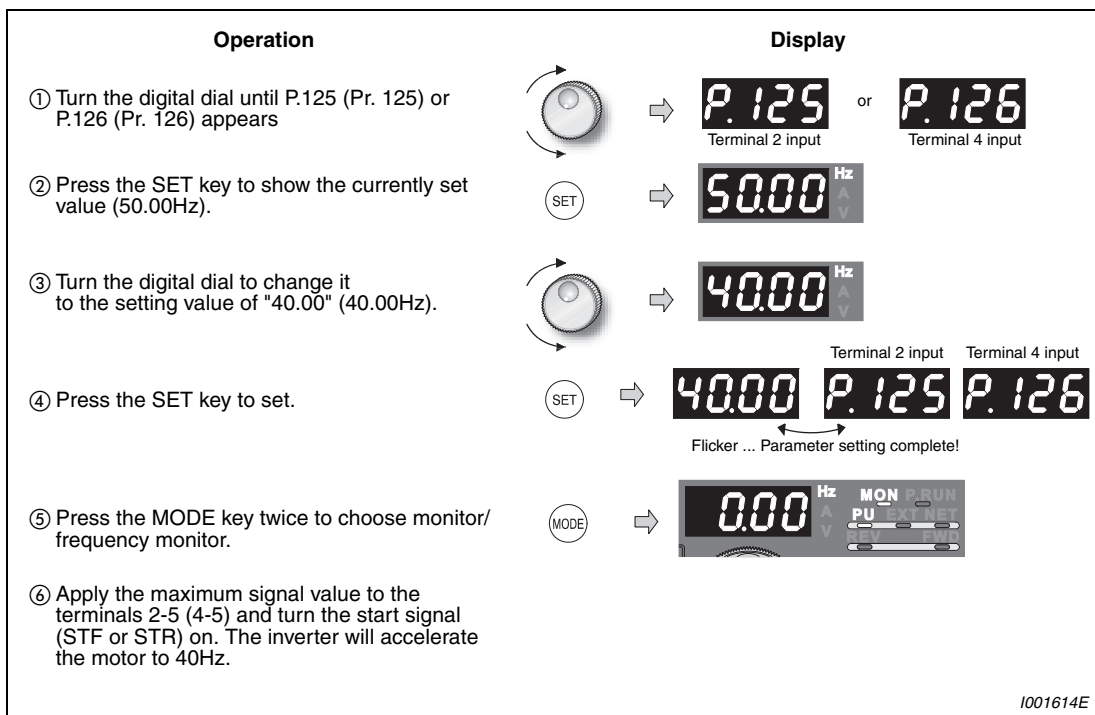

**Fig. 6-192:** Adjusting only the frequency without adjustment of a voltage (current)

**NOTES**

- Changing C4 (Pr. 903) or C7 (Pr. 905) (gain adjustment) value will not change the Pr. 20 value. The input of terminal 1 (frequency setting auxiliary input) is added to the speed setting signal.
- For the operation procedure using the parameter unit (FR-PU04 or FR-PU07), refer to the FR-PU04/FR-PU07 instruction manual.
- When setting the value to 120Hz or more, it is necessary to set Pr. 18 "High speed maximum frequency" to 120Hz or more. (Refer to page 6-168.)
- Make the bias frequency setting using calibration parameter C2 (Pr. 902) or C5 (Pr. 904). (Refer to page 6-388.)



**CAUTION:**  
 Take care when setting any value other than "0" as the bias speed at 0V (0/4mA). Even if a frequency command is not given, merely turning on the start signal will start the motor at the preset frequency.

## 6.20.6 Bias and gain of torque (magnetic flux) setting voltage (current) [Pr. 241, C16 (Pr. 919) to C19 (Pr. 920), C38 (Pr. 932) to C41 (Pr. 933)] Sensorless Vector

You can set the magnitude (slope) of the torque as desired in relation to the torque setting signal (0 to 5VDC, 0 to 10V or 4 to 20mA).

These parameters can be used to configure the inverter precisely for set point signals that either exceed or do not quite reach 5V or 10V or 20mA. These settings can also be used to configure inverse control (i.e. high output torque at minimum set point signal, minimum output torque at maximum set point signal)

Pr. No.	Name	Initial Value	Setting Range	Description	Parameters referred to	Refer to Section
<b>241</b>	Analog input display unit switchover <sup>②</sup>	0	0	Displayed in %	Select the unit of analog input display.	6.11.1
			1	Displayed in V/mA		
<b>C16 (919)</b>	Terminal 1 bias command (torque/magnetic flux) <sup>①</sup>	0 %	0–400%	Set the torque (magnetic flux) on the bias side of terminal 1 input.	20 Acceleration/ deceleration reference frequency	6.20.2
<b>C17 (919)</b>	Terminal 1 bias (torque/magnetic flux) <sup>①</sup>	0%	0–300%	Set the converted % of the bias side voltage (current) of terminal1 input.	73 Analog input selection	6.20.2
<b>C18 (920)</b>	Terminal 1 gain command (torque/magnetic flux) <sup>①</sup>	150%	0–400%	Set the torque (magnetic flux) of the terminal 1 input gain (maximum).	267 Terminal 4 input selection	6.20.2
<b>C19 (920)</b>	Terminal 1 gain (torque/magnetic flux) <sup>①</sup>	100%	0–300%	Set the converted % of the gain side voltage of terminal 1 input.	79 Operation mode selection	6.22.1
<b>C38 (932)</b>	Terminal 4 bias command (torque/magnetic flux) <sup>①</sup>	0%	0–400%	Set the torque (magnetic flux) on the bias side of terminal 4 input.	858 Terminal 4 function assignment	6.20.1
<b>C39 (932)</b>	Terminal 4 bias (torque/magnetic flux) <sup>①</sup>	20%	0–300%	Set the converted % of the bias side current (voltage) of terminal 4 input.	868 Terminal 1 function assignment	6.20.1
<b>C40 (933)</b>	Terminal 4 gain command (torque/magnetic flux) <sup>①</sup>	150%	0–400%	Set the torque (magnetic flux) of the terminal 4 input gain (maximum).		
<b>C41 (933)</b>	Terminal 4 gain (torque/magnetic flux) <sup>①</sup>	100%	0–300%	Set the converted % of the gain side current (voltage) of terminal 4 input.		

① The parameter number in parentheses is the one for use with the parameter unit (FR-PU04 or FR-PU07).

② The above parameter allow its setting to be changed during operation in any operation mode even if "0" (initial value) is set in Pr. 77 "Parameter write selection".

### Change functions of analog input terminal

In the initial setting status, terminal 1 and terminal 4 used for analog input are respectively set to speed setting auxiliary (speed limit auxiliary) and speed command (speed limit). To use an analog input terminal as torque command, torque limit input or magnetic flux command input, set Pr. 868 "Terminal 1 function assignment" and Pr. 858 "Terminal 4 function assignment" to change functions. (Refer to section 6.20.1).

## Relationship between analog input terminal and calibration parameter

Pr. 868 Setting	Terminal Function	Calibration Parameters			
		Bias setting		Gain setting	
0 (Initial value)	Frequency (speed) setting auxiliary	C2 (Pr. 902)	Terminal 2 frequency setting bias frequency	Pr. 125	Terminal 2 frequency setting gain frequency
		C3 (Pr. 902)	Terminal 2 frequency setting bias	C4 (Pr. 903)	Terminal 2 frequency setting gain
		C5 (Pr. 904)	Terminal 4 frequency setting bias frequency	Pr. 126	Terminal 4 frequency setting gain frequency
		C6 (Pr. 904)	Terminal 4 frequency setting bias	C7 (Pr. 905)	Terminal 4 frequency setting gain
1	Magnetic flux command	C16 (Pr. 919)	Terminal 1 bias command (torque/magnetic flux)	C18 (Pr. 920)	Terminal 1 gain command (torque/magnetic flux)
		C17 (Pr. 919)	Terminal 1 bias (torque/magnetic flux)	C19 (Pr. 920)	Terminal 1 gain (torque/magnetic flux)
2	Regenerative torque limit				
3	Torque command	C16 (Pr. 919)	Terminal 1 bias command (torque/magnetic flux)	C18 (Pr. 920)	Terminal 1 gain command (torque/magnetic flux)
4	Stall prevention operation level <sup>①</sup> /torque limit/torque command	C17 (Pr. 919)	Terminal 1 bias (torque/magnetic flux)	C19 (Pr. 920)	Terminal 1 gain (torque/magnetic flux)
5	Forward/reverse rotation speed limit	C12 (Pr. 917)	Terminal 1 bias frequency (speed)	C14 (Pr. 918)	Terminal 1 gain frequency (speed)
		C13 (Pr. 917)	Terminal 1 bias (speed)	C15 (Pr. 918)	Terminal 1 gain (speed)
6	Torque bias input	C16 (Pr. 919)	Terminal 1 bias command (torque/magnetic flux)	C18 (Pr. 920)	Terminal 1 gain command (torque/magnetic flux)
		C17 (Pr. 919)	Terminal 1 bias (torque/magnetic flux)	C19 (Pr. 920)	Terminal 1 gain (torque/magnetic flux)
9999	—	—	—	—	—

**Tab. 6-112:** Terminal 1 functional calibration parameter

- <sup>①</sup> Use Pr. 148 "Stall prevention level at 0V input" and Pr. 149 "Stall prevention level at 10V input" to adjust bias/gain of stall prevention operation level.

Pr. 858 Setting	Terminal Function	Calibration Parameters			
		Bias setting		Gain setting	
0 (Initial value)	Frequency command/ speed command	C5 (Pr. 904)	Terminal 4 frequency setting bias frequency	Pr. 126	Terminal 4 frequency setting gain frequency
		C6 (Pr. 904)	Terminal 4 frequency setting bias	C7 (Pr. 905)	Terminal 4 frequency setting gain
1	Magnetic flux command	C38 (Pr. 932)	Terminal 4 bias command (torque/magnetic flux)	C40 (Pr. 933)	Terminal 4 gain command (torque/magnetic flux)
4	Stall prevention operation level <sup>①</sup> /torque limit	C39 (Pr. 932)	Terminal 4 bias (torque/magnetic flux)	C41 (Pr. 933)	Terminal 4 gain (torque/magnetic flux)
9999	—	—	—	—	—

**Tab. 6-113:** Terminal 4 functional calibration parameter

- ① Use Pr. 148 "Stall prevention level at 0V input" and Pr. 149 "Stall prevention level at 10V input" to adjust bias/gain of stall prevention operation level.

**Change the frequency at maximum analog input [C18 (Pr. 920), C40 (Pr. 933)]**

To change the torque setting (gain) of the maximum analog input voltage (current), set a value to C18 (Pr. 920) or C40 (Pr. 933).

**Analog input bias/gain calibration [C16 (Pr. 919) to C19 (Pr. 920), C38 (Pr. 932) to C41 (Pr. 933)]**

The "bias" and "gain" functions are used to adjust the relationship between the input signal entered from outside the inverter to set the torque command and torque limit, e.g. 0 to 5V, 0 to 10V or 4 to 20mADC, and the torque.

Set the bias torque of terminal 1 input in C16 (Pr. 919). (It is factory-set to the torque at 0V)

Parameter C17 (Pr. 919) is the bias for the input signal at terminal 1, i.e. the minimum value of the analog signal. When signals are smaller than this value the frequency set point signal will be limited to the value set with C16.

Set the torque in C18 (Pr. 920) for the torque command voltage set with Pr. 73 Analog input selection. (initial value is 150%)

Parameter C19 (Pr. 920) sets the gain for the input signal on terminal 1, i.e. the maximum value of the analog signal connected to terminal 1. When signals exceed this value the frequency set point value is limited to the value stored in C18.

Set the bias torque of terminal 4 input in C38 (Pr. 932). (It is factory-set to the torque at 4mA)

Parameter C39 (Pr. 932) sets the bias of the input signal on terminal 4, i.e. the minimum value of the analog signal connected to terminal 4. When the signal on this terminal is lower than this value the frequency set point value is limited to the value set with C38. (This parameter is set to a default value of 20% at the factory, which corresponds to approx. 4mA.)

Set the torque in C40 (Pr. 933) for 20mA of the torque command current (4 to 20mA).

Parameter C41 (Pr. 933) sets the gain of the input signal on terminal 4, i.e. the maximum value of the analog signal connected to terminal 4. When the signal on this terminal is higher than this value the frequency set point value is limited to the value set with Pr. C40.

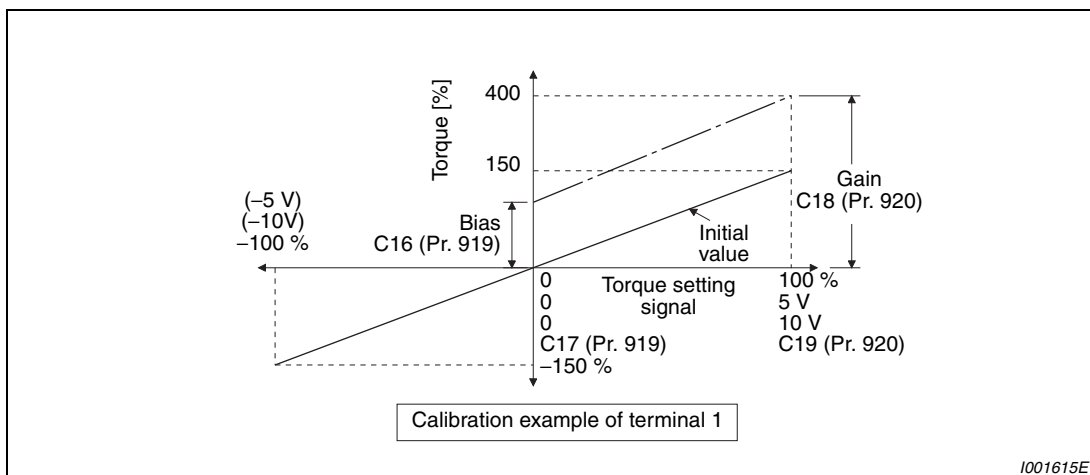

**Fig. 6-193:** Signal adjustment of terminal 1

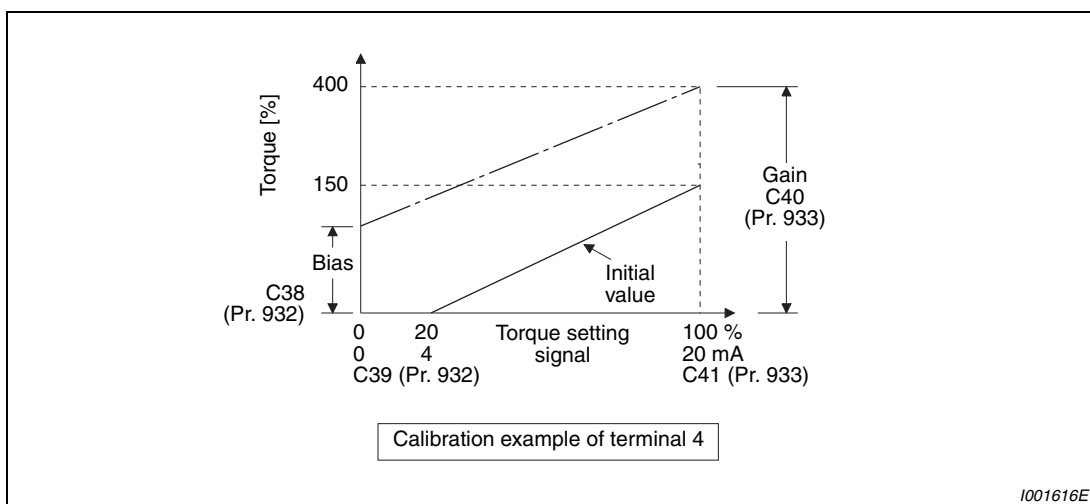

**Fig. 6-194:** Signal adjustment of terminal 4

There are the following three methods to adjust the torque setting voltage (current) bias and gain.

- Method to adjust any point without application of voltage (current) to across terminals 1-5 (4-5). (Refer to page 6-400)
- Method to adjust any point without application of voltage (current) to across terminals 1-5 (4-5). (Refer to page 6-401)
- Method to adjust torque only without adjustment of voltage (current). (Refer to page 6-402).

**NOTE**

When voltage/current input specifications were switched using Pr. 73 and Pr. 267, perform calibration without fail.

**Analog input display unit changing (Pr. 241)**

You can change the analog input display unit (%/V/mA) for analog input bias/gain calibration.

Display unit of C17 (Pr. 919), C19 (Pr. 920), C39 (Pr. 932), C41 (Pr. 933) changes as follows according to the terminal input specifications set in Pr. 73 and Pr. 267.

Analog Command (terminal 1, 4) (according to Pr. 73, Pr. 267)	Pr. 241 = 0 (initial value)	Pr. 241 = 1
0 to 5V input	0 to 5V → 0 to 100% (0.1%) is displayed.	0 to 100% → 0 to 5V (0.01V) is displayed.
0 to 10V input	0 to 10V → 0 to 100% (0.1%) is displayed.	0 to 100% → 0 to 10V (0.01V) is displayed.
0/4 to 20mA input	0 to 20mA → 0 to 100% (0.1%) is displayed.	0 to 100% → 0 to 20mA (0.01mA) is displayed.

**Tab. 6-114:** Units when displaying the set value

Note that the LEDs V or A also light up as an additional indicator when Pr. 241 is set to "1" and the display is set to the settings for C16 to C19 resp. C38 to C41.

**Adjustment method of torque setting voltage (current) bias and gain**

1.Method to adjust any point by application of voltage (current) to across the terminals 1-5 (4-5). The following example illustrating the procedure assumes that Pr. 241 is set to "0".

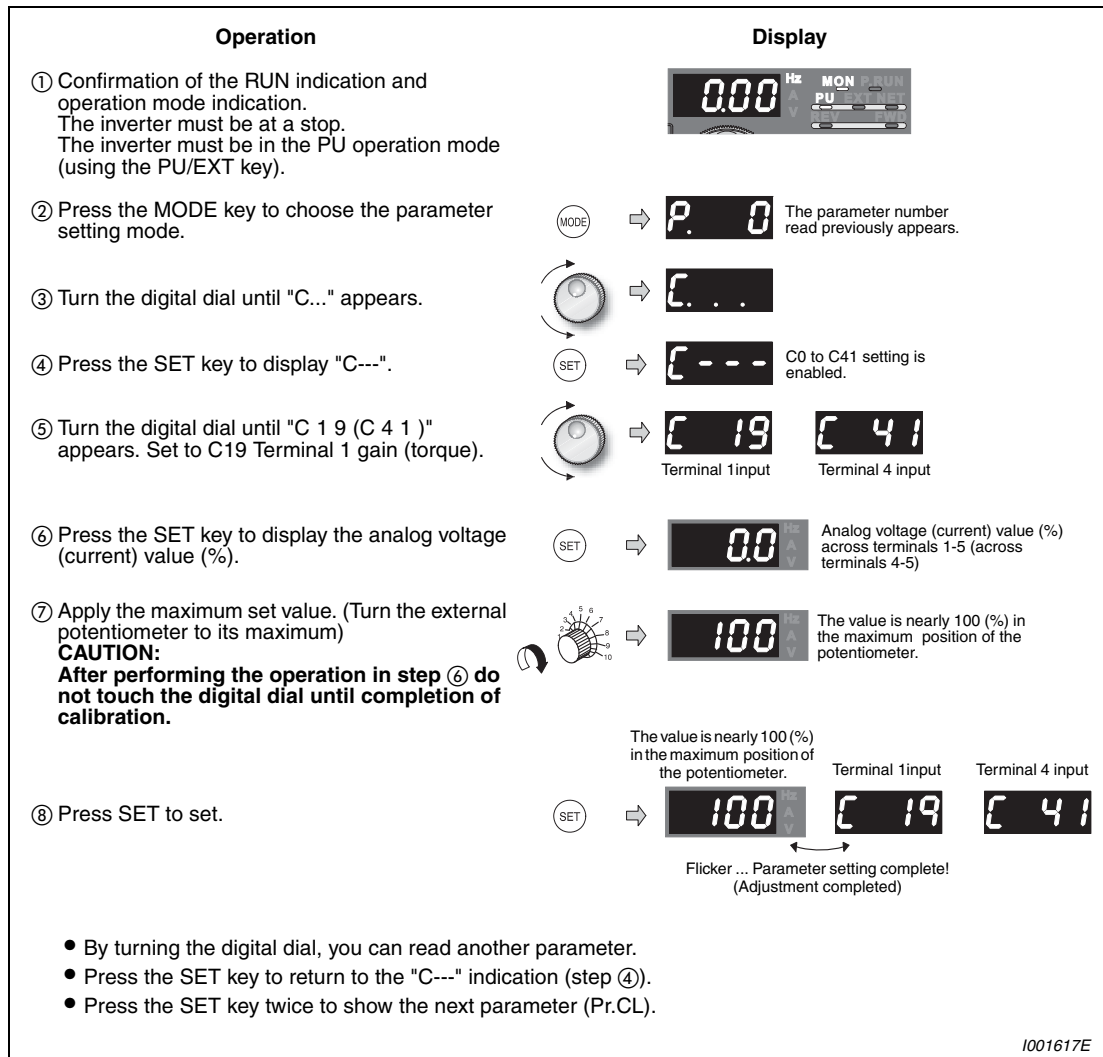

**Fig. 6-195: Bias and gain adjustment by application of an reference signal**

**NOTE**

Error code Er3 may be displayed when you save if torque setting value of gain and bias are less than approx. 5% apart. If this happens correct the frequency settings and save again.



2.Method to adjust any point without application of a voltage (current) to across terminals 2-5 (4-5). (This example shows how to change from 8V to 10V, assuming that Pr. 241 is set to "1".)

Operation	Display
① Confirmation of the RUN indication and operation mode indication. The inverter must be at a stop. The inverter must be in the PU operation mode (using the PU/EXT key)	
② Press the MODE key to choose the parameter setting mode.	⇒  The parameter number read previously appears.
③ Turn the digital dial until "C..." appears.	⇒
④ Press the SET key to display "C---".	⇒  C0 to C41 setting is enabled.
⑤ Turn the digital dial until "C 1 9 (C 4 1)" appears. Set to C19 Terminal 1 gain (torque).	⇒  Terminal 1 input  Terminal 4 input
⑥ Press the SET key to display the analog voltage (current) value (%).	⇒  Analog voltage (current) value (%) across terminals 1-5 (across terminals 4-5)
⑦ Turn the digital dial to set the gain voltage (%). "0V (0mA) equals to 0%, 10V (5V, 20mA) to 100%" <b>NOTE:</b> The current setting at the instant of turning is displayed.	⇒  The gain torque is reached when the analog voltage (current) value across terminals 1-5 (across terminals 4-5) is 100%.
⑧ Press SET to set.	⇒  Terminal 1 input  Terminal 4 input Flicker ... Parameter setting complete! (Adjustment completed)

- By turning the digital dial, you can read another parameter.
- Press the SET key to return to the "C---" indication (step ④).
- Press the SET key twice to show the next parameter (Pr.CL).

1001618E

**Fig. 6-196:** Bias and gain adjustment without application of an reference signal

**NOTE**

By pressing the digital dial after step ⑥, you can confirm the current frequency setting bias/gain setting. It cannot be confirmed after execution of step ⑦.

3.Method to adjust torque only without adjustment of gain voltage (current)  
(when changing gain torque from 150% to 130%)

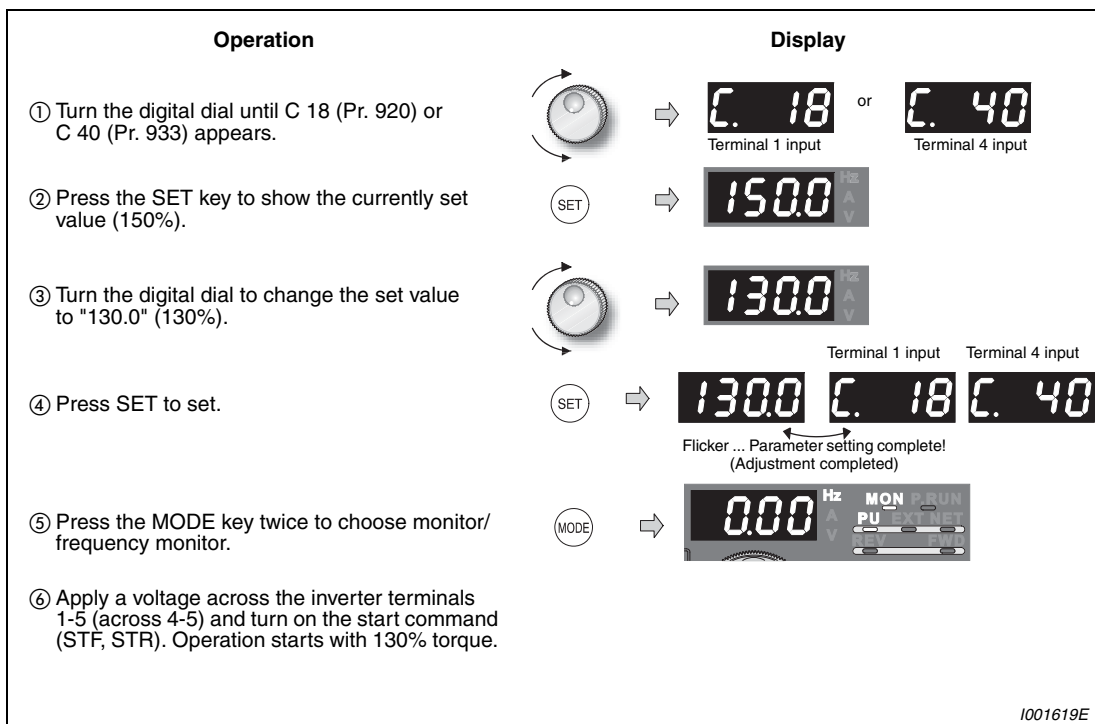

**Fig. 6-197:** Adjusting only the torque without adjustment of a voltage (current)

**NOTES**

For the operation procedure using the parameter unit (FR-PU04 or FR-PU07), refer to the FR-PU04/FR-PU07 instruction manual.

Set bias torque setting using calibration parameter C16 (Pr. 919) or C38 (Pr. 932). (Refer to page 6-397).



**CAUTION:**

**Take care when setting any value other than "0" as the bias torque at 0V (0mA). Torque is applied to the motor by merely tuning on the start signal without torque command.**

## 6.20.7 4mA input check of current input (Pr. 573)

When inputting 4 to 20mA current to terminal 2 or terminal 4, decrease in analog current input is detected to enable continuous operation even if input has decreased.

Pr. No.	Name	Initial Value	Setting Range	Description	Parameters referred to	Refer to Section
573	4mA input check selection	9999	1	When the current input drops to or below 2mA, the LF signal is output and inverter continues operation at the frequency (average value) just before current reaches 2mA.	73 Analog input selection	6.20.3
			9999	4mA input is not checked.	267 Terminal 4 input selection	6.20.2

### Operation at a current input decrease continues (Pr. 573 = 1)

When the input current of terminal 4 (terminal 2) falls to 2mA or below, output minor fault signal (LF) is output. The output frequency (average value) before detection is retained and operation at the retained frequency continues.

When the current input increases above 3mA, the LF signal output is turned off and the inverter operates according to the current input.

For the LF signal, set "98" (source logic) or "198" (sink logic) in Pr. 190 to Pr. 196 "Output terminal function selection" and assign functions to the output terminal.

Since turning off the start command clears the retained frequency, the inverter does not operate at the retained frequency even if restarted.

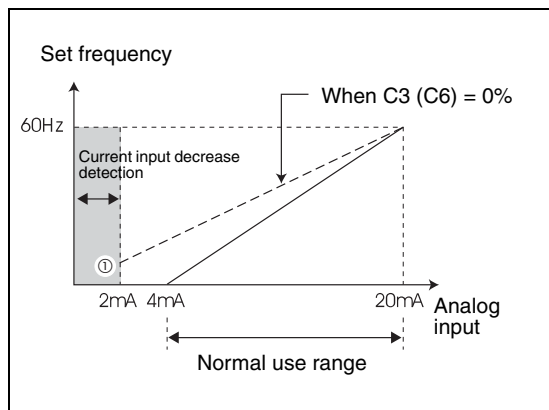

**Fig. 6-198:**  
4mA input check of current input

1001196E

\*When Pr. 573 = 1, input decrease is detected (LF signal output) even if the analog input value to bias frequency of terminal 2 or terminal 4 is set to 2mA or less using C2 (Pr. 902) or C5 (Pr. 904) and the value is not as bias frequency settings.

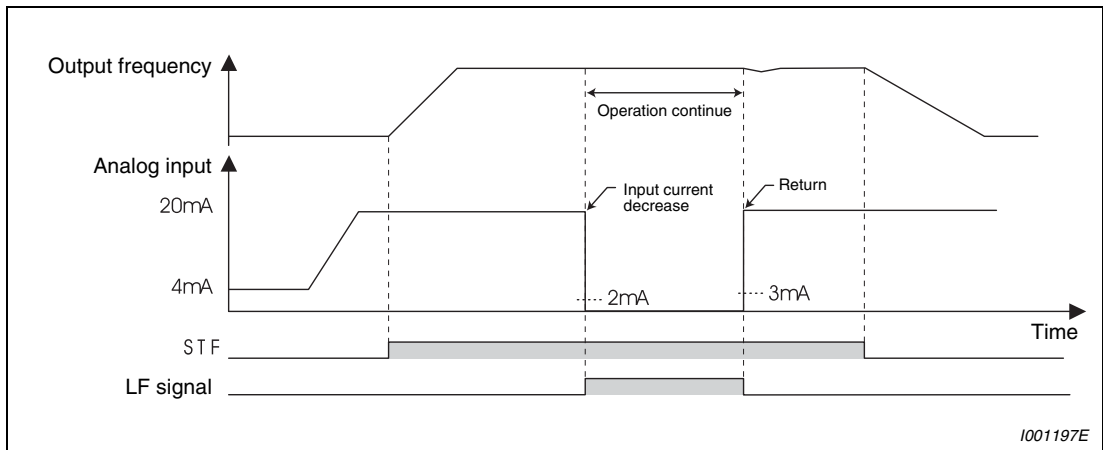

**Fig. 6-199:** 4mA input check during external operation (Pr. 573 = 1)

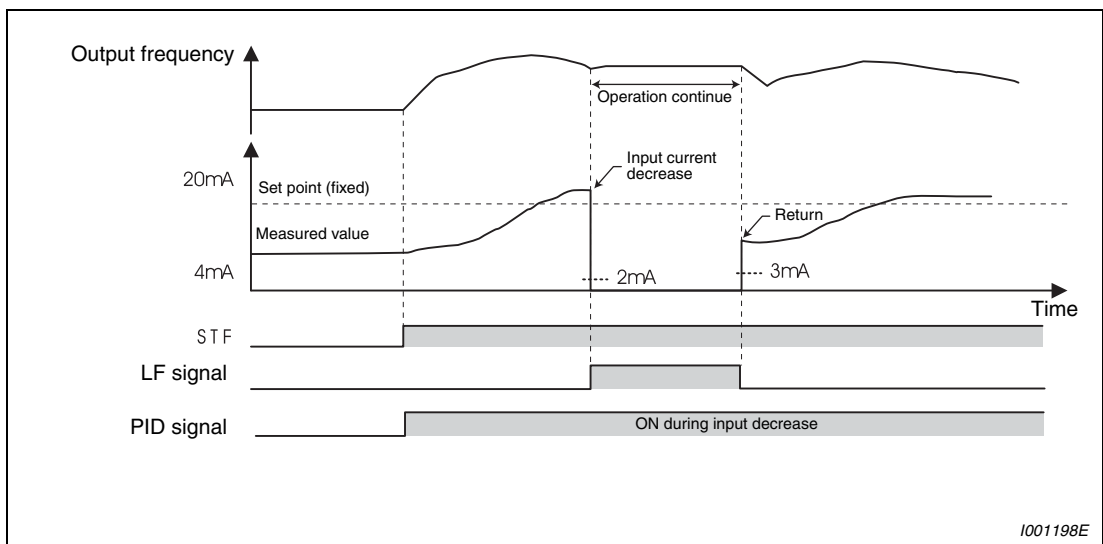

**Fig. 6-200:** 4mA input check during PID control (reverse action, Pr. 573 = 1)

**NOTE**

When terminal assignment is changed using Pr. 190 to Pr. 196 "Output terminal function selection", the other functions may be affected. Please make setting after confirming the function of each terminal.

The function 4mA input check is related to following functions:

Function	Operation (Pr. 573 = 1)	Refer to Page
Minimum frequency	Even if the input current decreases, minimum frequency setting clamp is valid.	6.8.1
Multi-speed operation	Operation by multiple speed signal has precedence even if input current decreases. (Frequency is not retained when the input current decreases.) Operation stops when a multi-speed signal turns off.	6.10.1
Jog operation	The Jog signal has precedence even during decrease in input current. (Frequency is not retained when the input current decreases.) Operation stops when the jog signal is turned off during decrease in input current. PU/jog operation is enabled during PID control. At this time, PU/jog operation has precedence during decrease in input current.	6.10.2
MRS	Output is shut off by the MRS signal even if input current decreases. (The inverter stops when the MRS signal is turned off.)	6.14.2
Remote setting	The retained frequency will not change even if remote acceleration/deceleration and clear are performed during decrease in input current. Reflected at restoration.	6.10.4
Retry	When retry was successful at error occurrence during decrease in input current, retained frequency was not cleared and operation continues.	6.17.1
Added compensation, override function	Operation of added compensation (terminal 1) and override compensation (terminal 2) are invalid during decrease in input current.	6.20.3
Input filter time constant	The value before filtering is detected. When input current decreases, frequency after filtering (average value) is retained.	6.20.4
Forward/reverse rotation prevention	Motor rotation direction can be restricted independently of 4mA input check setting.	6.21.3
PID control	Although PID operation is stopped when input current decreases, the X14 signal remains on. (PID operation is valid.)	6.24.1
Power failure stop	Even if input current decreases when under voltage or power failure occurs, the motor stops according to the setting of power-failure deceleration stop function.	6.16.2
Pump function	If auxiliary motor switchover conditions of pump function is satisfied even when input current decreases, motor connection/release operation is performed.	
Traverse function	When input current decreases, traverse operation is performed using retained frequency as reference.	6.24.7
Switch-over	When the switchover function is operated, frequency is the same as that of the retained frequency. Note that if 4mA input is made invalid once in switchover mode, the frequency is not retained next time.	6.22.1

**Tab. 6-115:** Functions related to the 4mA input check function

## 6.21 Misoperation prevention and parameter setting restriction

Purpose	Parameters that must be set		Refer to Section
Limit reset function Make alarm stop when PU is disconnected Stop from PU	Reset selection/ disconnected PU detection/ PU stop selection	Pr. 75	6.21.1
Prevention of parameter rewrite	Parameter write selection	Pr. 77	6.21.2
Prevention of reverse rotation of the motor	Reverse rotation prevention selection	Pr. 78	6.21.3
Display necessary parameters	Reverse rotation prevention selection	Pr. 160, Pr. 172 to Pr. 174	6.21.4
Control of parameter write by communication	EEPROM write selection	Pr. 342	6.23.4

### 6.21.1 Reset selection/disconnected PU detection/PU stop selection (Pr. 75)

You can select the reset input acceptance, disconnected PU (FR-DU07/FR-PU04/FR-PU07) connector detection function and PU stop function.

Pr. No.	Name	Initial Value	Setting Range		Description	Parameters referred to	Refer to Section
75	Reset selection/ disconnected PU detection/ PU stop selection	14	01800 or less	0-3/ 14-17	For the initial value, reset always enabled, without disconnected PU detection, and with PU stop function are set.	250 Stop selection	6.13.3
			02160 or more	0-3/ 14-17/ 100-103/ 114-117			

The Pr. 75 value can be set any time. Also, if parameter (all) clear is executed, this setting will not return to the initial value.

Pr. 75	Reset Selection	Disconnected PU Detection	PU Stop Selection	Reset Limit (01800 or more)
0	Reset input always enabled.	If the PU is disconnected, operation will be continued.	Pressing the STOP key decelerates the motor to a stop only in the PU operation mode.	No function
1	Enabled only when the protective function is activated			
2	Reset input always enabled.	When the PU is disconnected, the inverter output is shut off.	Pressing the STOP key decelerates the motor to a stop only in the PU operation mode.	
3	Enabled only when the protective function is activated			
14 (initial value)	Reset input always enabled.	If the PU is disconnected, operation will be continued.	Pressing the STOP key decelerates the motor to a stop in any of the PU, external and communication operation modes.	
15	Enabled only when the protective function is activated			
16	Reset input always enabled.	When the PU is disconnected, the inverter output is shut off.	Pressing the STOP key decelerates the motor to a stop only in the PU operation mode.	
17	Enabled only when the protective function is activated			
100 ①	Reset input always enabled.	If the PU is disconnected, operation will be continued.	Pressing the STOP key decelerates the motor to a stop only in the PU operation mode.	Function
101 ①	Enabled only when the protective function is activated			
102 ①	Reset input always enabled.	When the PU is disconnected, the inverter output is shut off.	Pressing the STOP key decelerates the motor to a stop in any of the PU, external and communication operation modes.	
103 ①	Enabled only when the protective function is activated			
114 ①	Reset input always enabled.	If the PU is disconnected, operation will be continued.	Pressing the STOP key decelerates the motor to a stop in any of the PU, external and communication operation modes.	
115 ①	Enabled only when the protective function is activated			
116 ①	Reset input always enabled.	When the PU is disconnected, the inverter output is shut off.	Pressing the STOP key decelerates the motor to a stop in any of the PU, external and communication operation modes.	
117 ①	Enabled only when the protective function is activated			

**Tab. 6-116: Setting of parameter 75**

① Available with the 02160 or more.

### Reset selection

You can select the operation timing of reset function (RES signal, reset command through communication) input.

When Pr. 75 is set to any of "1, 3, 15, 17, 101, 103, 115, 117", a reset can be input only when the protective function is activated.

### NOTES

When the reset signal (RES) is input during operation, the motor coasts since the inverter being reset shuts off the output. Also, the cumulative value of the electronic thermal relay function is cleared.

When the RESET signal is applied continuously while the frequency inverter is in an error-free condition the message "err" will blink in the display.

The reset key of the PU is valid only when the protective function is activated, independently of the Pr. 75 setting.

**Disconnected PU detection**

This function detects that the PU (FR-DU07/FR-PU04/FR-PU07) has been disconnected from the inverter for longer than 1s and causes the inverter to provide an alarm output (E.PUE) and come to an alarm stop.

When Pr. 75 is set to any of "0, 1, 14, 15, 100, 101, 114, 115", operation is continued if the PU is disconnected.

**NOTES**

When the PU has been disconnected since before power-on, it is not judged as an alarm.

To make a restart, confirm that the PU is connected and then reset the inverter.

The motor decelerates to a stop when the PU is disconnected during PU jog operation with Pr. 75 set to any of "0, 1, 14, 15" (operation is continued if the PU is disconnected).

When RS-485 communication operation is performed through the PU connector, the reset selection/PU stop selection function is valid but the disconnected PU detection function is invalid.

**PU stop selection**

In any of the PU operation, external operation and network operation modes, the motor can be stopped by pressing the STOP key of the PU

When the inverter is stopped by the PU stop function (refer to section 4.3 "Operation panel FR-DU07") in the external operation mode, "PS" is displayed but an alarm is not output. An alarm output is not provided.

When Pr. 75 is set to any of "0 to 3, 100 to 103", deceleration to a stop by the STOP key is valid only in the PU operation mode.

**NOTE**

The motor will also decelerate to a stop (PU stop) when is input during operation in the PU mode through RS-485 communication with Pr. 551 "PU mode operation command source selection" set to "1" (PU mode RS-485 terminal).



### Restarting method when stop was made by pressing the STOP key from the PU during external operation ("PS" is displayed)

#### Operation panel FR-DU07

- ① After the motor has decelerated to a stop, turn off the STF or STR signal.
- ② Press the PU/EXT key to change to the PU operation mode. The PU indication is lit. The message "PS" is canceled.
- ③ Press the PU/EXT key to change to the external operation mode. The EXT indication is lit.
- ④ Turn on the STF or STR signal.

#### Parameter unit FR-PU04 or FR-PU07

- ① After the motor has decelerated to a stop, turn off the STF or STR signal.
- ② Press the EXT key. The message "PS" is canceled.
- ③ Turn on the STF or STR signal.

The motor can be restarted by making a reset using a power supply reset or RES signal.

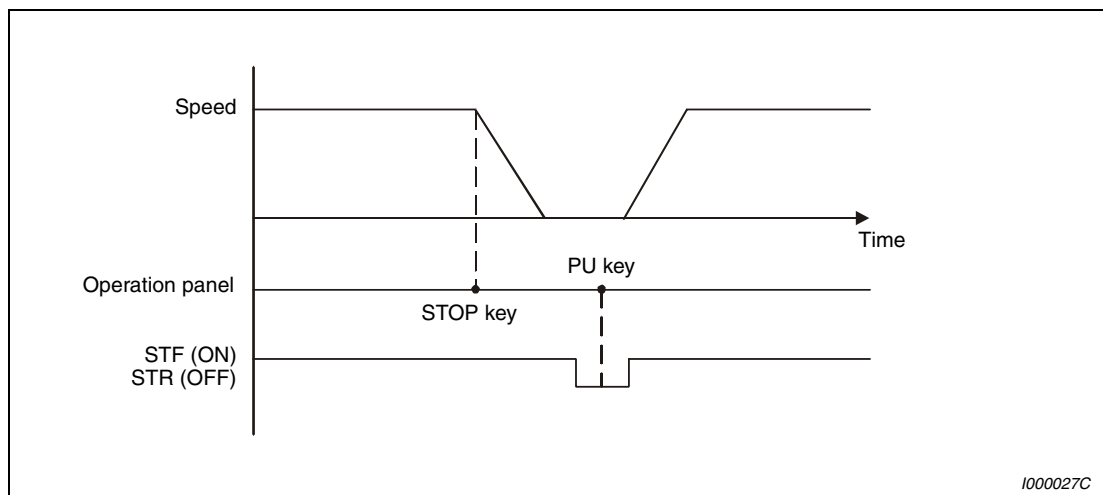

**Fig. 6-201:** Stop during external operation

#### NOTE

If Pr. 250 Stop selection is set to other than "9999" to select coasting to a stop, the motor will not be coasted to a stop but decelerated to a stop by the PU stop function during external operation.

To restart after the inverter is stopped by PU with PLC function, reset using a power supply rest or RES signal. (sending stop signal from GX Developer, can also perform the reset.)



#### WARNING:

**Do not reset the inverter with the start signal on. Doing so will cause the inverter to start immediately after a reset, leading to hazardous conditions.**

**Reset limit**

Setting can be made for the 02160 or more.

You can set Pr. 75 to disable reset operation until the thermal cumulative amount reaches "0" when a thermal trip (THM, THT) or an over current trip (OC1 to OC3) occurs consecutively twice.

When Pr. 75 = "100 to 103, 114 to 117", reset limit is made valid.

**NOTE**

When the power-on reset (no control power is supplied) is made, the thermal cumulative amount is cleared.

## 6.21.2 Parameter write selection (Pr. 77)

You can select whether write to various parameters can be performed or not. Use this function to prevent parameter values from being rewritten by misoperation.

Pr. No.	Name	Initial Value	Setting Range	Description	Parameters referred to	Refer to Section
77	Parameter write selection	0	0	Write is enabled only during a stop.	79 Operation mode selection	6.22.1
			1	Parameter write is not enabled.		
			2	Parameter write is enabled in any operation mode regardless of operation status.		

Pr. 77 can be always set independently of the operation mode and operation status.

### Write parameters only at a stop (Pr. 77 = 0)

Parameters can be written only during a stop in the PU operation mode.

The half-tone screened parameters in the parameter list (Tab. 6-1) can always be written, regardless of the operation mode and operation status. However, Pr. 72 "PWM frequency selection" and Pr. 240 "Soft-PWM operation selection" can be written during operation in the PU operation mode, but cannot be written in external operation mode.

### Disable parameter write (Pr. 77 = 1)

Parameter write is not enabled. (Reading is enabled.)

Parameter clear and all parameter clear cannot be performed, either.

The parameters given below can be written if Pr. 77 = 1.

Parameter	Name
22	Stall prevention operation level
75	Reset selection/disconnected PU detection/PU stop selection
77	Parameter write selection
79	Operation mode selection
160	User group read selection

**Tab. 6-117:** Parameters that can be written even if Pr. 77 = 1

**Write parameters during operation (Pr. 77 = 2)**

Parameters can always be written. The following parameters cannot be written during operation if Pr. 77 = 2. Stop operation when changing their parameter settings.

Parameter	Description
19	Base frequency voltage
23	Stall prevention operation level compensation factor at double speed
48	Second stall prevention operation current
49	Second stall prevention operation frequency
60	Energy saving control selection
61	Reference current
66	Stall prevention operation reduction starting frequency
71	Applied motor
79	Operation mode selection
80	Motor capacity (simple magnetic flux vector control)
81	Number of motor poles
82	Motor excitation current
83	Motor rated voltage
84	Rated motor frequency
90 to 94	Motor constants
95	Rated motor frequency
96	Auto tuning setting/status
100 to 109	Adjustable 5 points V/f parameter
135 to 139	Parameter for electronic bypass sequence
178 to 196	I/O terminal function selection
255	Life alarm status display
256	Inrush current limit circuit life display
257	Control circuit capacitor life display
258	Main circuit capacitor life display
291	Pulse train I/O selection
292	Automatic acceleration/deceleration
293	Acceleration/deceleration separate selection
329	Digital input increments selection (Parameter for the plug-in option FR-A7AX)
343	Communication error count
414	PLC function operation selection
415	Inverter operation lock mode setting
450	Second applied motor
451	Second motor control method selection
453	Second motor capacity
454	Number of second motor poles
455	Second motor excitation current
456	Rated second motor voltage
457	Rated second motor frequency
458 to 462	Second motor constant
463	Second motor auto tuning setting/status

**Tab. 6-118:** Parameters that cannot be written during operation

Parameter	Description
541	Frequency command sign selection (CC-Link) (Parameter for the plug-in option FR-A7NC)
563	Energizing time carrying-over times
564	Operating time carrying-over times
570	Multiple rating setting
574	Second motor online auto tuning
800	Control method selection
819	Easy gain tuning selection
858	Terminal 4 function assignment
859	Torque current
860	Second motor torque current
868	Terminal 1 function assignment

**Tab. 6-118:** Parameters that cannot be written during operation

### 6.21.3 Reverse rotation prevention selection (Pr. 78)

In some applications (fans, pumps) it is necessary to ensure that the motor cannot be reversed. This can be achieved with Pr. 78.

Pr. No.	Name	Initial Value	Setting Range	Description	Parameters referred to	Refer to Section
<b>78</b>	Reverse rotation prevention selection	0	0	Both forward and reverse rotations allowed	—	
			1	Reverse rotation disabled		
			2	Forward rotation disallowed		

Set this parameter when you want to limit the motor rotation to only one direction.

This parameter is valid for all of the reverse rotation and forward rotation keys of the operation panel (FR-DU07), parameter unit (FR-PU04/FR-PU07), signals (STF, STR signals) via external terminals, and the forward and reverse rotation commands through communication.

### 6.21.4 User groups (Pr. 160, Pr. 172 to Pr. 174)

Parameter which can be read from the operation panel and parameter unit can be restricted. In the initial setting, only the simple mode parameters are displayed.

Pr. No.	Name	Initial Setting	Setting Range	Description	Parameters referred to	Refer to Section
160	User group read selection	9999	9999	Only the simple mode parameters can be displayed.	550 NET mode operation command source selection 551 PU mode operation command source selection	6.22.3 6.22.3
			0	The simple mode and extended parameters can be displayed		
			1	Only parameters registered in the user group can be displayed.		
172	User group registered display/batch clear ①	0	(0-16)	Displays the number of cases registered as a user group (Read only)		
			9999	Batch clear the user group registration		
173	User group registration ①	9999	0-999/9999	Set the parameter numbers to be registered to the user group.		
174	User group clear ①	9999	0-999/9999	Set the parameter numbers to be cleared from the user group.		

① The values read from Pr. 173 and Pr. 174 are always "9999".

#### Display of simple mode parameters and extended parameters (Pr. 160)

When Pr. 160 is set to "9999" (initial value), only the simple mode parameters can be displayed on the operation panel (FR-DU07) and parameter unit (FR-PU04). (Refer to the parameter list Tab. 6-1 for the simple mode parameters.)

Setting "0" to Pr. 160 enables the display of the simple mode parameters and extended parameters.

#### NOTES

When a plug-in option is fitted to the inverter, the option parameters can also be read.

When reading the parameters using the communication option, all parameters (simple mode, extended mode, parameters for options) can be read regardless of the Pr. 160 setting.

When reading the parameters using the RS-485 terminal, all parameters can be read regardless of the Pr. 160 setting by setting Pr. 550 "NET mode operation command source selection" and Pr. 551 "PU mode operation command source selection".

Pr. 551	Pr. 550	Pr. 160 Valid/Invalid
1 (RS-485 terminal)	—	Valid
2 (PU) (initial value)	0 (communication option)	Valid
	1 (RS-485)	Invalid (all readable)
	9999 (auto-detect) (initial value)	With communication option: valid Without communication option: invalid (all readable)
3 (USB)		

Pr. 15 "Jog frequency", Pr. 16 "Jog acceleration/deceleration time", Pr. 991 "PU contrast adjustment" are displayed as simple mode parameters when a parameter unit FR-PU04 or FR-PU07 is mounted.

**User group function (Pr. 160, Pr. 172 to Pr. 174)**

The user group function is designed to display only the parameters necessary for setting.

From among all parameters, a maximum of 16 parameters can be registered to a user group. When Pr. 160 is set to "1", only the parameters registered to the user group can be accessed. (Reading of parameters other than the user group registration is disabled.)

To register a parameter to the user group, set its parameter number to Pr. 173. To delete a parameter from the user group, set its parameter number to Pr. 174. To batch-delete the registered parameters, set Pr. 172 to "9999".

**Registration of parameter to user group (Pr. 173))**

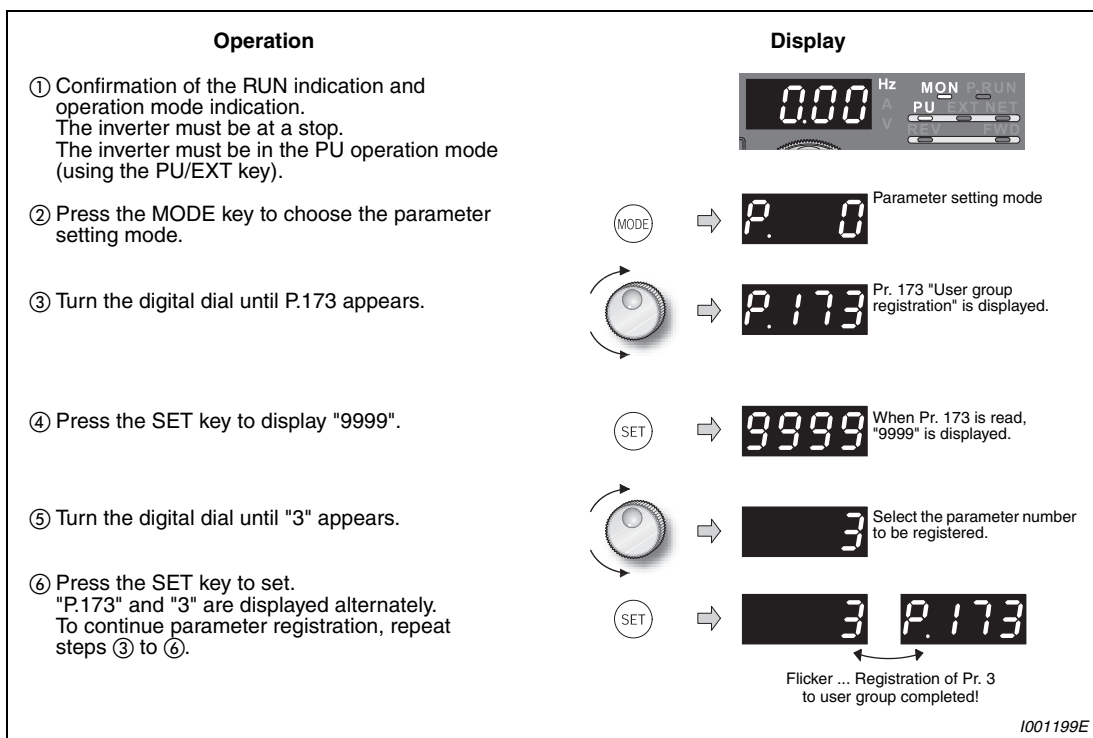

**Fig. 6-202: When registering Pr. 3 to user group**



**Deletion of parameter from user group (Pr. 174)**

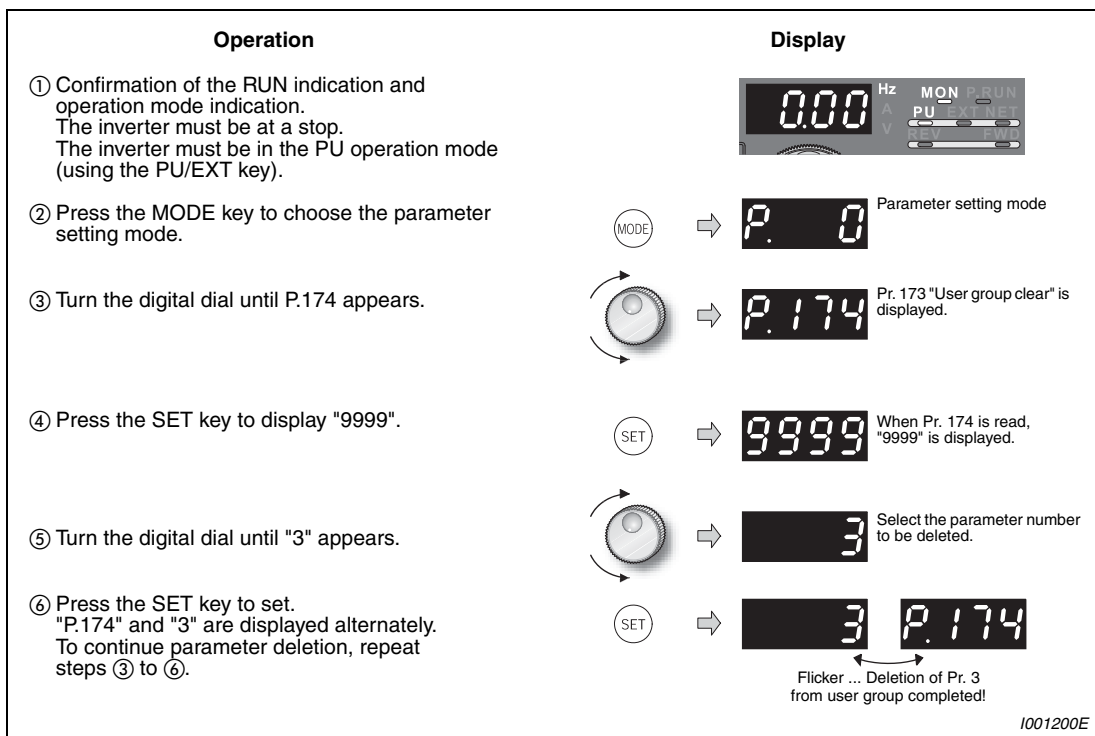

**Fig. 6-203:** When deleting Pr. 3 from user group

**NOTES**

- | Pr. 77, Pr. 160 and Pr. 991 can always be read, independently of the user group setting.
- | Pr. 77, Pr. 160 and Pr. 172 to Pr. 174 cannot be registered to the user group.
- | When Pr. 173 or Pr. 174 is read, "9999" is always displayed. Although "9999" can be written, no function is available.
- | When any value other than "9999" is set to Pr. 172, no function is available.

## 6.22 Selection of operation mode and operation location

Purpose	Parameters that must be set		Refer to Section
Operation mode selection	Operation mode selection	Pr. 79	6.22.1
Started in network operation mode	Operation mode at power on	Pr. 79, Pr. 340	6.22.2
Selection of control source	Selection of control source, speed command source and control location during communication operation	Pr. 338, Pr. 339, Pr. 550, Pr. 551	6.22.3

### 6.22.1 Operation mode selection (Pr. 79)

Used to select the operation mode of the inverter.

Mode can be changed as desired between operation using external signals (external operation), operation from the PU (FR-DU07/FR-PU04/FR-PU07), combined operation of PU operation and external operation (external/PU combined operation, and network operation (when RS-485 terminals or a communication option is used).

Pr. No.	Name	Initial Value	Setting Range	Description	Parameters referred to	Refer to Section
79	Operation mode selection	0	0	External/PU switchover mode External operation mode at power on	15 Jog frequency	6.10.2
			1	Fixed to PU operation mode	4-6 Multi-speed operation	6.10.1
			2	Fixed to external operation mode Operation can be performed by switching between external and NET operation mode	24-27 232-239	6.21.1
			3	External/PU combined operation mode 1 Running frequency: PU (FR-DU07/FR-PU04/FR-PU07) setting or external signal input (multi-speed setting, across terminals 4-5 (valid when AU signal turns on)) Start signal: External signal input (terminal STF, STR)	75 Reset selection/ disconnected PU detection/ PU stop selection	6.26.2
			4	External/PU combined operation mode 2 Running frequency: External signal input (terminal 2, 4, 1, JOG, multi-speed setting, etc.) Start signal: Input from the PU (FR-DU07/FR-PU04/FR-PU07), (FWD/REV keys)	161 Frequency setting/ key lock operation selection	6.14.1
			6	Switch-over mode Switch among PU operation, external operation, and NET operation while keeping the same operation status.	178-189 Input terminal function selection	6.14.5
			7	External operation mode (PU operation interlock) X12 signal ON: Can be shifted to PU operation mode (output stop during external operation) X12 signal OFF: Operation mode can not be switched to PU operation mode.	190-196 Output terminal function selection	6.22.2
					340 Communication start-up mode selection	6.22.3
					550 NET mode operation command source selection	

The above parameter can be changed during a stop in any operation mode.

**Operation mode basics**

The operation mode is to specify the source of inputting the start command and set frequency of the inverter.

- Select the "external operation mode" when performing operation by basically using the control circuit terminals and providing potentiometers, switches, etc. externally.
- Select the "PU operation mode" when inputting the start command and frequency setting through communication from the operation panel (FR-DU07), parameter unit (FR-PU04/FR-PU07) or PU connector.
- Select the "network operation mode (NET operation mode)" when using the RS-485 terminals or communication option.

The operation mode can be selected from the operation panel or with the communication instruction code.

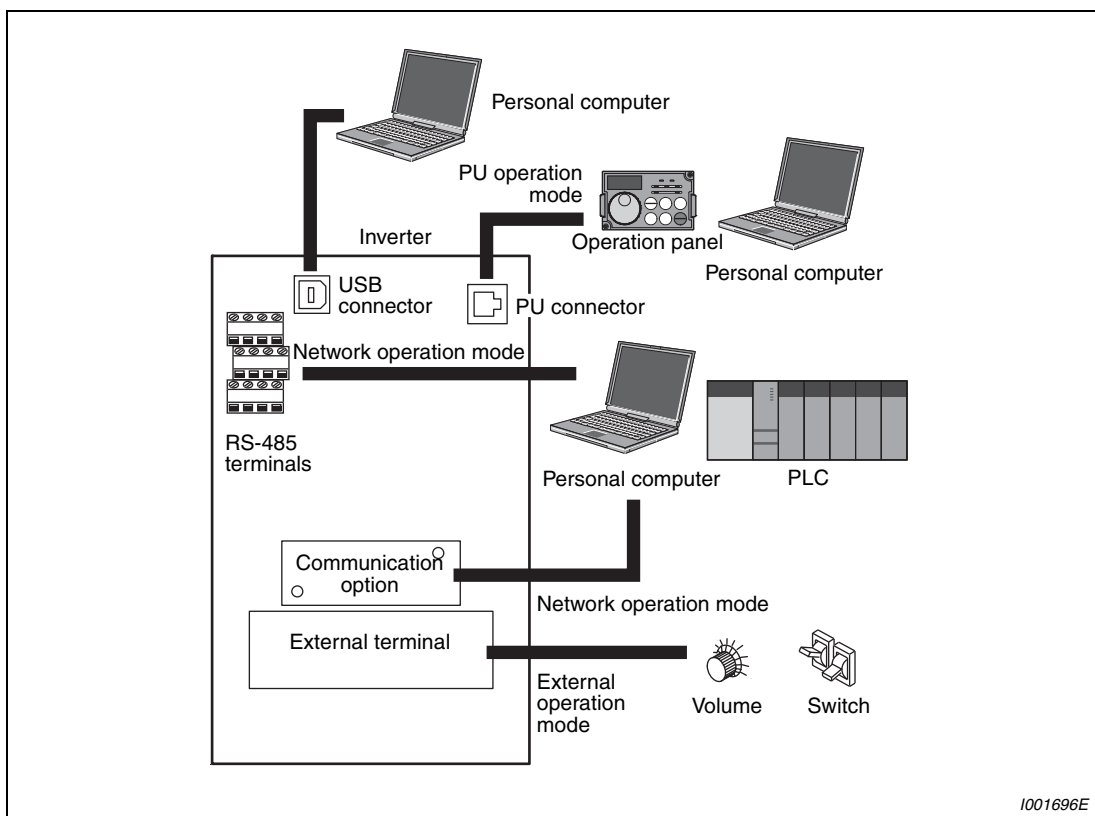

**Fig. 6-204:** Operation modes of the inverter

**NOTES**

Either "3" or "4" may be set to select the PU/external combined operation, and these settings differ in starting method.

In the initial setting, the stop function by of the PU (FR-DU07) (PU stop selection) is valid also in other than the PU operation mode. (Refer to Pr. 75 "Reset selection/disconnected PU detection/PU stop selection".)

**Operation mode switching method**

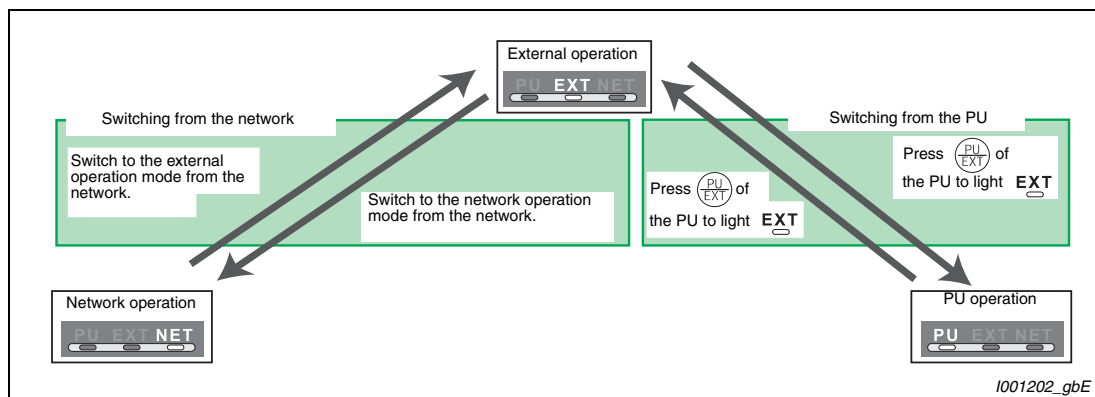

**Fig. 6-205:** Switching the operation mode when Pr. 340 = 0, 1 or 2

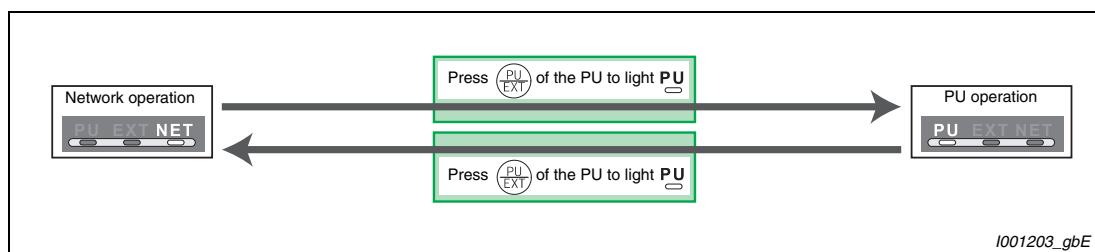

**Fig. 6-206:** Switching the operation mode when Pr. 340 = 10 or 12

**NOTE**

- For switching of operation by external terminals, refer to the following:
- PU operation external interlock signal (X12 signal) (refer to page 6-426)
  - PU-external operation switch-over signal (X16) (refer to page 6-427)
  - PU-NET operation switchover signal (X65) (refer to page 6-428)
  - External-NET operation switchover signal (X66) (refer to page 6-428)
  - Pr. 340 "Communication start-up mode selection" (refer to page 6-430)

### Operation mode selection flow

In the following flowchart, select the basic parameter setting and terminal connection related to the operation mode:

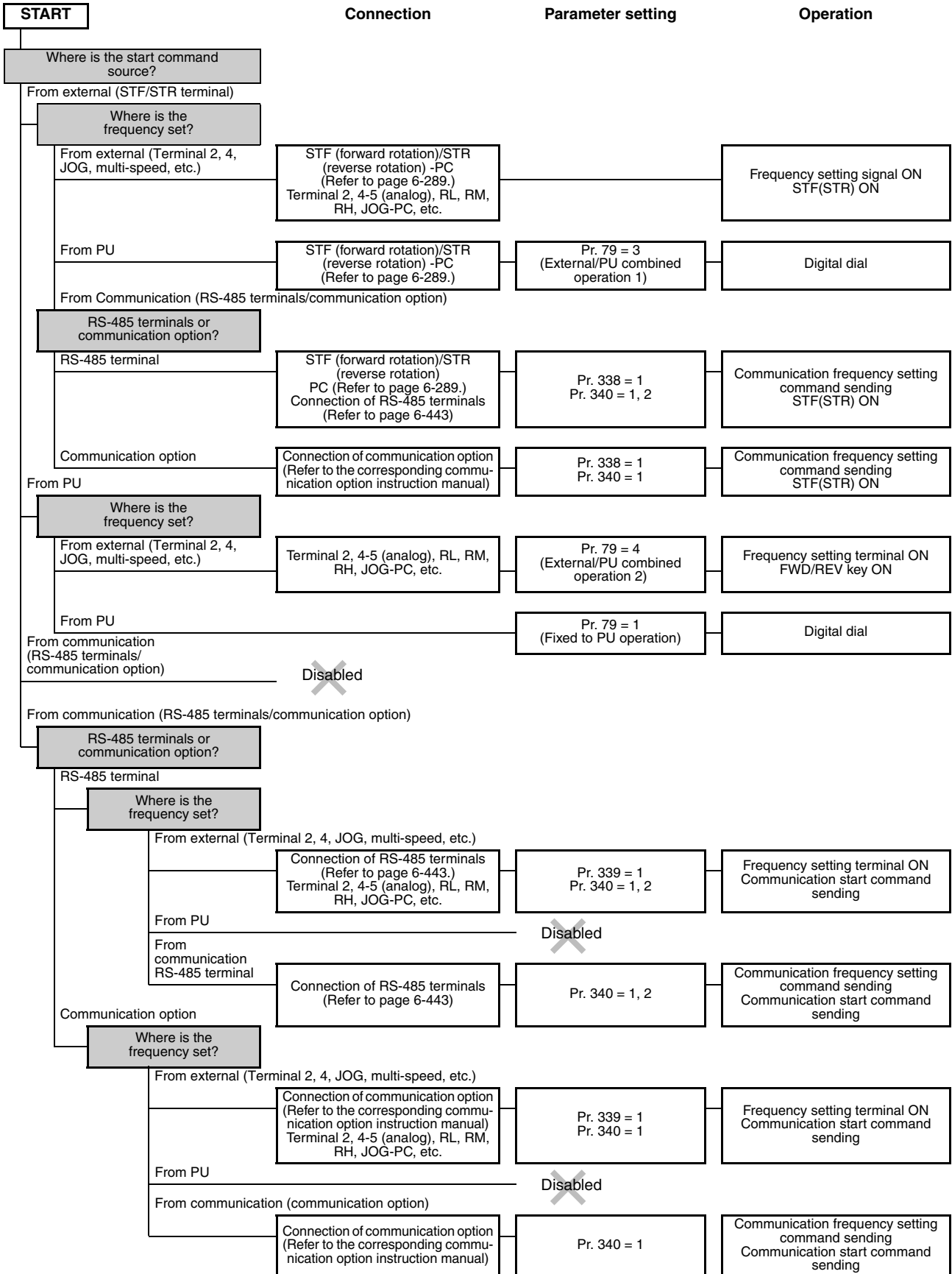

**External operation mode (Pr. 79 = 0, 2)**

Select the external operation mode when performing operation by providing a frequency setting potentiometer, start switch, etc. externally and connecting them to the control circuit terminals of the inverter.

Basically, parameter changing is disabled in external operation mode. (Some parameters can be changed. Refer to Tab. 6-1 for the parameter list.)

When "0" or "2" is selected for Pr. 79, the inverter enters the external operation mode at power on. (When using the network operation mode, refer to section 6.22.2.)

If you don't need to change the parameter settings frequently you can set the unit to external mode permanently by setting Pr. 79 to "2". (If you need to change parameter settings frequently external mode should be activated by setting Pr. 79 to "0". Then the frequency inverter will switch to external mode automatically when the power is switched on but it can be switched to PU mode by pressing the PU/EXT key. You can then make the parameter changes in PU mode and switch back to external mode again afterwards by pressing PU/EXT again.)

The STF and STR signal are used as a start command, and the terminal 2, 4, multi-speed setting, JOG signal, etc. are used as frequency setting.

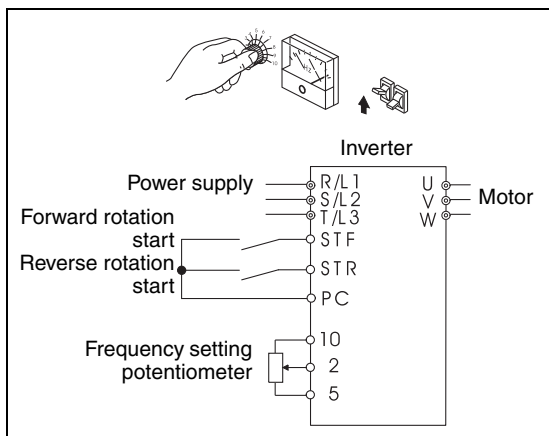

**Fig. 6-207:**  
External operation mode

1001205E

**PU operation mode (Pr. 79 = 1)**

Select the PU operation mode when performing operation by only the key operation of the operation panel (FR-DU07) or parameter unit (FR-PU04/FR-PU07). Also select the PU operation mode when making communication using the PU connector.

When "1" is selected for Pr. 79, the inverter enters the PU operation mode at power on. You cannot change to the other operation mode.

The setting dial of the operation panel can be used for setting like a volume. (Pr. 161 "Frequency setting/key lock operation selection", refer to section 6.26.2.)

When PU operation mode is selected, the PU operation mode signal (PU) can be output. For the terminal used for the PU signal output, assign the function by setting "10 (source logic) or 110 (sink logic)" in any of Pr. 190 to Pr. 196 "output terminal function selection".

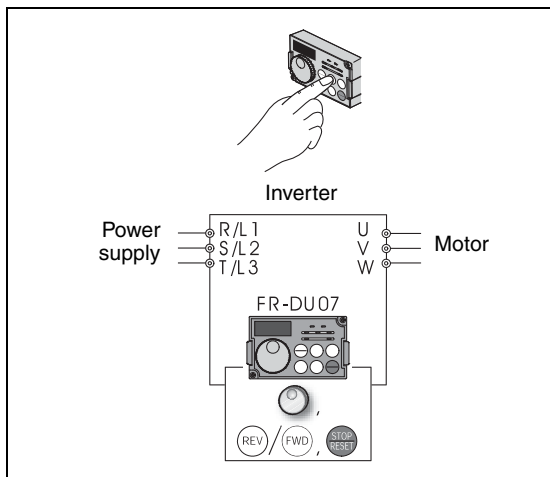

**Fig. 6-208:**  
PU operation mode

1001206E

**PU/external combined operation mode 1 (Pr. 79 = 3)**

Select the PU/external combined operation mode 1 when making frequency setting from the operation panel FR-DU07 (digital dial) or parameter unit (FR-PU04/FR-PU07) and inputting the start command with the external start switch.

Select "3" for Pr. 79. You cannot change to the other operation mode by using the PU/EXT-key.

When a frequency is input from the external signal by multi-speed setting, it has a higher priority than the frequency setting of the PU. When AU is on, the terminal 4 is used.

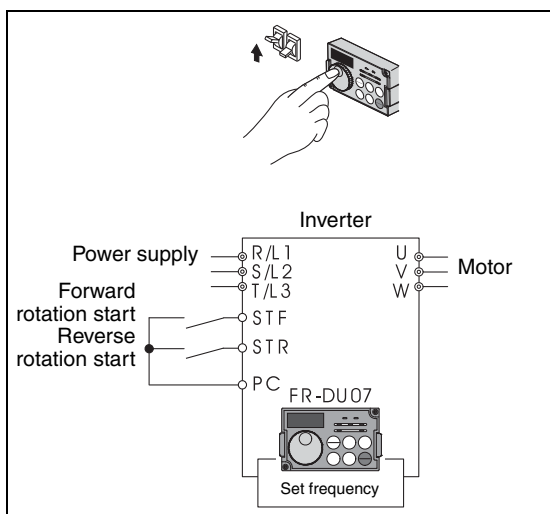

**Fig. 6-209:**  
Combined operation mode 1

1001207E

**PU/external combined operation mode 2 (Pr. 79 = 4)**

Select the PU/external combined operation mode 2 when making frequency setting from the external potentiometer, multi-speed or JOG signal and inputting the start command by key operation of the operation panel (FR-DU07) or parameter unit (FR-PU04/FR-PU07).

Select "4" for Pr. 79. You cannot change to the other operation mode by using the PU/EXT-key.

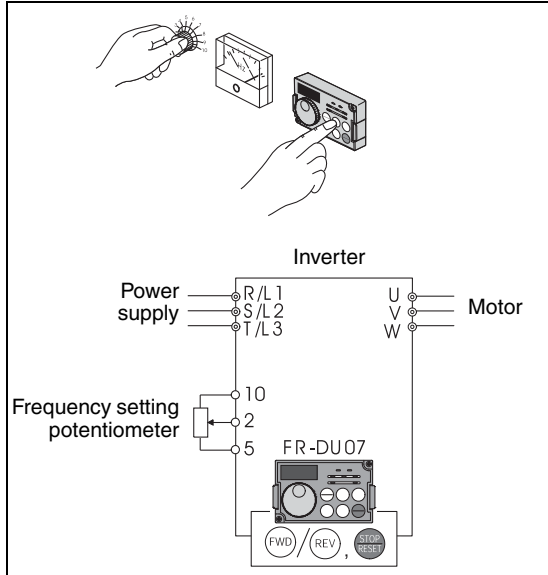

**Fig. 6-210:**  
Combined operation mode 2

1001208E



**Switch-over mode (Pr. 79 = 6)**

While continuing operation, you can switch between the PU operation, external operation and network operation (when RS-485 terminals or communication option is used).

Operation Mode Switching	Switching Operation/Operating Status
External operation ⇒ PU operation	Select the PU operation mode with the operation panel or parameter unit. Rotation direction is the same as that of external operation. The frequency set with the volume (frequency setting potentiometer) or like is used unchanged. (Note that the setting will disappear when power is switched off or the inverter is reset.)
External operation ⇒ NET operation	Send the mode change command to network operation mode through communication. Rotation direction is the same as that of external operation. The value set with the setting volume (frequency setting potentiometer) or like is used unchanged. (Note that the setting will disappear when power is switched off or the inverter is reset.)
PU operation ⇒ external operation	Press the external operation key of the operation panel, parameter unit. The rotation direction is determined by the input signal of the external operation. The set frequency is determined by the external frequency setting signal.
PU operation ⇒ NET operation	Send the mode change command to network operation mode through communication. Rotation direction and set frequency are the same as those of PU operation.
NET operation ⇒ external operation	Command to change to external mode is transmitted by communication. Rotation direction is determined by the external operation input signal. The set frequency is determined by the external frequency setting signal.
NET operation ⇒ PU operation	Select the PU operation mode with the operation panel or parameter unit. The rotation direction and set frequency signal in network operation mode are used unchanged.

**Tab. 6-119:** Operation states in the switch-over mode

**WARNING:**

**When using switch-over mode please note that in some switch-over operations the rotation direction command and the frequency setting value are "transferred" to the "new" operating mode (refer to Tab. 6-119 for details). When this happens the drive will run in the new operating mode even though it has not (yet) received any control commands.**

**It is extremely important to take this into account and take the necessary steps to ensure that performing these switch-over operations cannot cause hazardous conditions.**

**PU operation interlock (Pr. 79 = 7)**

The PU operation interlock function is designed to forcibly change the operation mode to external operation mode when the PU operation interlock signal (X12) input turns off. This function prevents the inverter from being inoperative by the external command if the mode is accidentally left unswitched from the PU operation mode.

Set "7" (PU operation interlock) in Pr. 79. For the terminal used for X12 signal (PU operation interlock signal) input, set "12" to any of Pr. 178 to Pr. 189 "Input terminal function selection" to assign the function. (Refer to section 6.14.1 for Pr. 178 to Pr. 189.)

When the X12 signal has not been assigned, the function of the MRS signal switches from MRS (output stop) to the PU operation interlock signal.

X12 (MRS) Signal	Function/Operation	
	Operation mode	Parameter write
ON	Operation mode (external, PU, NET) switching enabled Output stop during external operation	Parameter write enabled (Pr. 77 "Parameter write selection", depending on the corresponding parameter write condition (Refer to Tab. 6-1 for the parameter list))
OFF	Forcibly switched to external operation mode External operation allowed. Switching to PU or NET operation mode disabled	Parameter write disabled with exception of Pr. 79

**Tab. 6-120: Function of the X12 signal**

**Function/operation changed by switching on-off the X12 (MRS) signal**

Operation Condition		X12 (MRS) Signal	Operation Mode	Operating Status	Switching to PU, NET Operation Mode
Operation mode	Status				
PU/NET	During stop	ON → OFF ①	External ②	If external operation frequency setting and start signal are entered, operation is performed in that status.	Disallowed
	Running	ON → OFF ①			Disallowed
External	During stop	OFF → ON	External ②	Stop	Enabled
		ON → OFF			Disallowed
	Running	OFF → ON		During operation → output stop	Disallowed
		ON → OFF		Output stop → During operation	Disallowed

**Tab. 6-121: Switching the X12 (MRS) signal**

- ① The operation mode switches to external operation mode independently of whether the start signal (STF, STR) is on or off. Therefore, the motor is run in external operation mode when the X12 (MRS) signal is turned off with either of STF and STR on.
- ② At alarm occurrence, pressing the STOP/RESET key of the operation panel resets the inverter.

**NOTES**

If the X12 (MRS) signal is on, the operation mode cannot be switched to PU operation mode when the start signal (STF, STR) is on.

When the MRS signal is used as the PU interlock signal, the MRS signal serves as the normal MRS function (output stop) by turning on the MRS signal and then changing the Pr. 79 value to other than "7" in the PU operation mode. Also as soon as "7" is set in Pr. 79, the signal acts as the PU interlock signal.

When the MRS signal is used as the PU operation interlock signal, the logic of the signal is as set in Pr. 17. When Pr. 17 = 2, read ON as OFF and OFF as ON in the above explanation.

Changing the terminal assignment using Pr. 178 to Pr. 189 "Input terminal function selection" may affect the other functions. Please make setting after confirming the function of each terminal.

### Switching of operation mode by external terminal (X16)

When external operation and operation from the operation panel are used together, use of the PU-external operation switching signal (X16) allows switching between the PU operation mode and external operation mode during a stop (during a motor stop, start command off).

When Pr. 79 = any of "0, 6, 7", the operation mode can be switched between the PU operation mode and external operation mode. (Pr. 79 = 6 switch-over mode can be changed during operation)

For the terminal used for X16 signal input, set "16" to any of Pr. 178 to Pr. 189 "Input terminal function selection" to assign the function.

Pr. 79	X16 Signal State Operation Mode		Remarks
	ON (external)	OFF (PU)	
0 (initial value)	External operation mode	PU operation mode	Can be switched to external, PU or NET operation mode
1	PU operation mode		Fixed to PU operation mode
2	External operation mode		Fixed to external operation mode (Can be switched to NET operation mode)
3 / 4	External/PU combined operation mode		External/PU combined mode fixed
6	External operation mode	PU operation mode	Can be switched to external, PU or NET operation mode with operation continued
7	X12 (MRS) ON	PU operation mode	Can be switched to external, PU or NET operation mode (Output stop in external operation mode)
	X12 (MRS) OFF	Fixed to external operation mode (Forcibly switched to external operation mode.)	

**Tab. 6-122:** Operation mode switching by signal X16

#### NOTES

The operation mode status changes depending on the setting of Pr. 340 "Communication start-up mode selection" and the ON/OFF states of the X65 and X66 signals. (For details, refer to page 6-428.)

The priorities of Pr. 79, Pr. 340 and signals are:  
Pr. 79 > X12 > X66 > X65 > X16 > Pr. 340

Changing the terminal assignment using Pr. 178 to Pr. 189 "Input terminal function selection" may affect the other functions. Please make setting after confirming the function of each terminal.

### Switching of operation mode by external terminal (X65, X66)

When Pr. 79 = any of "0, 2, 6, 7", the operation mode switching signals (X65, X66) can be used to change the PU or external operation mode to network operation mode during a stop (during a motor stop or start command off). (Pr. 79 = 6 switch-over mode can be changed during operation)

When switching between the network operation mode and PU operation mode:

- ① Set Pr. 79 to "0" (initial value), "6" or "7". (At the Pr. 79 setting of "7", the operation mode can be switched when the X12 (MRS) signal turns on.)
- ② Set "10" or "12" in Pr. 340 "Communication start-up mode selection".
- ③ Set "65" to any of Pr. 178 to Pr. 189 to assign the PU-NET operation switching signal (X65) to the external terminal.
- ④ The operation mode changes to PU operation mode when the X65 signal turns on, or to network operation mode when the X65 signal turns off.

Pr. 340	Pr. 79	X65 Signal State		Remarks	
		ON (PU)	OFF (NET)		
10 / 12	0 (initial setting)	PU operation mode ①	PU operation mode ②	Cannot be switched to external operation mode	
	1	PU operation mode		Fixed to PU operation mode	
	2	NET operation mode		Fixed to NET operation mode	
	3 / 4	External/PU combined operation mode		External/PU combined mode fixed	
	6	PU operation mode ①	NET operation mode ②	Operation mode can be switched with operation continued Cannot be switched to external operation mode	
	7	X12 (MRS) ON	PU operation mode ①	NET operation mode ② ③	Output stop in external operation mode
		X12 (MRS) OFF	External operation mode		Forcibly switched to external operation mode

**Tab. 6-123:** Operation mode switching by signal X65

- ① NET operation mode when the X66 signal is on.
- ② PU operation mode when the X16 signal is off. PU operation mode also when Pr. 550 "NET mode operation command source selection" = 1 (communication option control source) and the communication option is not fitted.
- ③ External operation mode when the X16 signal is on.

When switching between the network operation mode and external operation mode:

- ① Set Pr. 79 to "0" (initial value), "2", "6" or "7". (At the Pr. 79 setting of "7", the operation mode can be switched when the X12 (MRS) signal turns on.)
- ② Set "0" (initial value), "1" or "2" in Pr. 340 "Communication start-up mode selection".
- ③ Set "66" to any of Pr. 178 to Pr. 189 to assign the external-NET operation switching signal (X66) to the external terminal.
- ④ The operation mode changes to network operation mode when the X66 signal turns on, or to external operation mode when the X66 signal turns off.

Pr. 340	Pr. 79	X66-Signal		Remarks	
		ON (PU)	OFF (NET)		
0 (initial value)/ 1 / 2	0 (initial value)	NET operation mode ①	External operation mode ②		
	1	PU operation mode		Fixed to PU operation mode	
	2	NET operation mode ①	External operation mode	Cannot be switched to PU operation mode	
	3 / 4	External/PU combined operation mode		External/PU combined mode fixed	
	6	NET operation mode ①	External operation mode ②	Operation mode can be switched with operation continued	
	7	X12 (MRS) ON	NET operation mode ①	External operation mode ②	Output stop in external operation mode
		X12 (MRS) OFF	External operation mode		Forcibly switched to external operation mode

**Tab. 6-124:** Operation mode switching by signal X66

- ① PU operation mode also when Pr. 550 "NET mode operation command source selection" = 1 (communication option control source) and the communication option is not fitted.
- ② PU operation mode when the X16 signal is off. When the X65 signal has been assigned, the operation mode changes with the ON/OFF state of the X65 signal.

**NOTES**

The priorities of Pr. 79, Pr. 340 and signals are:  
Pr. 79 > X12 > X66 > X65 > X16 > Pr. 340

Changing the terminal assignment using Pr. 178 to Pr. 189 "Input terminal function selection" may affect the other functions. Please make setting after confirming the function of each terminal.

## 6.22.2 Operation mode at power on (Pr. 79, Pr. 340)

When power is switched on or when power comes back on after instantaneous power failure, the inverter can be started up in network operation mode.

After the inverter has started up in the network operation mode, parameter write and operation can be performed from a program.

Set this mode for communication operation using the inverter RS-485 terminals or communication option.

Pr. No.	Name	Initial Value	Setting Range	Description	Parameters referred to	Refer to Section
79	Operation mode selection	0	0-4/6/7	Select the operation mode. (Refer to page 6-421.)	57 Restart coasting time 79 Operation mode selection	6.16.1 6.22.1
			0	As set in Pr. 79.		
			1/2	Started in network operation mode. When the setting is "2", it will resume the pre-instantaneous power failure operation mode after an instantaneous power failure occurs.		
340	Communication start-up mode selection <sup>①</sup>	0	10/12	Started in network operation mode. Operation mode can be changed between the PU operation mode and network operation mode from the operation panel. When the setting is "12", it will resume the pre-instantaneous power failure operation mode after an instantaneous power failure occurs.		

The above parameters can be changed during a stop in any operation mode.

① The parameters can be set whenever the communication option is connected. (Refer to section 6.21.4.)

**Specify operation mode at power on (Pr. 340)**

Depending on the Pr. 79 and Pr. 340 settings, the operation mode at power on (reset) changes as described below:

Pr. 340	Pr. 79	Operation Mode at Power on, Power Restoration, Reset	Operation Mode Switching
0 (initial value)	0 (initial value)	External operation mode	Can be switched to external, PU or NET operation mode <sup>②</sup>
	1	PU operation mode	Fixed to PU operation mode
	2	External operation mode	Can be switched to external or NET operation mode Switching to PU operation mode disabled
	3 / 4	External/PU combined operation mode	Operation mode switching disabled
	6	External operation mode	Can be switched to external, PU or NET operation mode with operation continued
	7	X12 (MRS) signal ON: External operation mode	Can be switched to external, PU or NET operation mode <sup>②</sup>
X12 (MRS) signal OFF: External operation mode		Fixed to external operation mode (Forcibly switched to external operation mode.)	
1 / 2 <sup>①</sup>	0	NET operation mode	Same as when Pr. 340 = 0
	1	PU operation mode	
	2	NET operation mode	
	3 / 4	External/PU combined operation mode	
	6	NET operation mode	
	7	X12 (MRS) signal ON: NET operation mode	
X12 (MRS) signal OFF: External operation mode			
10 / 12 <sup>①</sup>	0	NET operation mode	Can be switched to PU or NET operation mode <sup>③</sup>
	1	PU operation mode	Same as when Pr. 340 = 0
	2	NET operation mode	Fixed to NET operation mode
	3 / 4	External/PU combined operation mode	Same as when Pr. 340 = 0
	6	NET operation mode	Can be switched to PU or NET operation mode with operation continued <sup>③</sup>
	7	External operation mode	Same as when Pr. 340 = 0

**Tab. 6-125:** Operation mode of the inverter at power on

- <sup>①</sup> The Pr. 340 setting "2" or "12" is mainly used for communication operation using the inverter RS-485 terminals. When Pr. 57 "Restart coasting time" ≠ 9999 (selection of automatic restart after instantaneous power failure), the inverter will resume the same operation state which was in before after power has been restored from an instantaneous power failure.
- <sup>②</sup> The operation mode cannot be switched directly between the PU operation mode and network operation mode.
- <sup>③</sup> Operation mode can be changed between the PU operation mode and network operation mode with the PU/EXT key of the operation panel (FR-DU07) and X65 signal.

### 6.22.3 Operation command source and speed command source during communication operation (Pr. 338, Pr. 339, Pr. 550, Pr. 551)

When the inverter RS-485 terminals or communication option is used, the external operation command and speed command can be made valid. Also, the control command source in the PU operation mode can be selected.

Pr. No.	Name	Initial Value	Setting Range	Description	Parameters referred to	Refer to Section
<b>338</b>	Communication operation command source	0	0	Operation command source communication	28 Multi-speed input compensation selection 59 Remote function selection 79 Operation mode selection	6.10.3 6.10.4 6.22.1
			1	Operation command source external		
<b>339</b>	Communication speed command source	0	0	Speed command source communication		
			1	Speed command source external (Frequency setting from communication is invalid, terminal 2 and 1 setting from external is valid)		
			2	Speed command source external (Frequency setting from communication is valid, terminal 2 and 1 setting from external is invalid)		
<b>550</b>	NET mode operation command source selection ①	9999	0	Communication option valid		
			1	Inverter RS-485 terminal valid		
			9999	Automatic recognition of the communication option Normally, the RS-485 terminals are valid. When the communication option is fitted, the communication option is valid.		
<b>551</b>	PU mode operation command source selection ①	2	1	Select the inverter RS-485 terminals as the PU operation mode control source.		
			2	Select the PU connector as the PU operation mode control source.		
			3	Select the USB connector as the PU operation mode control source.		

The above parameters can be set whenever the communication option is connected. (Refer to section 6.21.4.)

① Pr 550 and Pr. 551 are always write-enabled.

#### Select the control source of the network operation mode (Pr. 550)

Either the inverter RS-485 terminals or communication option can be specified as the source of control in network operation mode.

For example, set Pr. 550 to "1" when executing parameter write, start command or frequency setting from the inverter RS-485 terminals in the network operation mode independently of whether the communication option is connected or not.

#### NOTE

Since Pr. 550 = 9999 (Automatic recognition of the communication option) in the initial setting, parameter write, start command and frequency setting cannot be executed by communication using the inverter RS-485 terminals when the communication option is fitted. (Monitor and parameter read can be performed.)



**Select the control source of the PU operation mode (Pr. 551)**

Either the PU connector or inverter RS-485 terminals can be specified as the source of control in the PU operation mode.

In the PU operation mode, set Pr. 551 to "1" when executing parameter write, start command or frequency setting through communication from the unit RS-485 terminals. Set Pr. 551 to "3" for communication from the USB connector.

**NOTE**

The PU operation mode has a higher priority when Pr. 550 = 1 (NET mode RS-485 terminals) and Pr. 551 = 1 (PU mode RS-485 terminals). When the communication option is not fitted, therefore, the operation mode cannot be switched to network operation mode.

Changed setting value is made valid when powering on or resetting the inverter.

Pr. 550	Pr. 551	Operation Mode of Control Source				Remarks
		PU connector	USB connector	RS-485 terminals	Communication option	
0	1	—	—	PU operation mode ①	NET operation mode ②	
	2 (initial value)	PU operation mode	—	—	NET operation mode ②	
	3	—	PU operation mode	—	NET operation mode ②	
1	1	—	—	PU operation mode ①	—	Switching to NET operation mode disabled
	2 (initial value)	PU operation mode	—	NET operation mode	—	
	3	—	PU operation mode	NET operation mode	—	
9999 (initial value)	1	—	—	PU operation mode ①	NET operation mode ②	
				—	NET operation mode ②	Communication option fitted
	2 (initial value)	PU operation mode	—	NET operation mode	—	Communication option not fitted
				—	NET operation mode ②	Communication option fitted
	3	—	PU operation mode	NET operation mode	—	Communication option not fitted
				—	NET operation mode ②	Communication option fitted

**Tab. 6-126: Parameter 550 and 551 settings**

- ① The Modbus-RTU protocol cannot be used in the PU operation mode. When using the Modbus-RTU protocol, set Pr. 551 to "2".
- ② When the communication option is not fitted, the operation mode cannot be switched to network operation mode.

**Controllability through communication**

Operation Location	Condition (Pr. 551)	Command	Operation Mode					NET operation (when RS-485 terminals are used) <sup>⑥</sup>	NET operation (when communication option is used) <sup>⑦</sup>
			PU operation	External operation	External/PU combined operation mode 1 (Pr. 79 = 3)	External/PU combined operation mode 2 (Pr. 79 = 4)			
Control by RS-485 communication from PU connector or operation from the USB connector	2 (PU connector) or 3 (USB connector)	Run command (start, stop)	✓	◇ <sup>③</sup>	◇ <sup>③</sup>	✓		◇ <sup>③</sup>	
		Running frequency setting	✓	—	✓	—		—	
		Monitor	✓	✓	✓	✓		✓	
		Parameter write	✓ <sup>④</sup>	— <sup>⑤</sup>	✓ <sup>④</sup>	✓ <sup>④</sup>		— <sup>⑤</sup>	
		Parameter read	✓	✓	✓	✓		✓	
		Inverter reset	✓	✓	✓	✓		✓	
	Except for 2 (3)	Run command (start, stop)	◇ <sup>③</sup>	◇ <sup>③</sup>	◇ <sup>③</sup>	◇ <sup>③</sup>		◇ <sup>③</sup>	
		Running frequency setting	—	—	—	—		—	
		Monitor	✓	✓	✓	✓		✓	
		Parameter write	— <sup>⑤</sup>	— <sup>⑤</sup>	— <sup>⑤</sup>	— <sup>⑤</sup>		— <sup>⑤</sup>	
		Parameter read	✓	✓	✓	✓		✓	
		Inverter reset	✓	✓	✓	✓		✓	
Control by communication from inverter RS-485 terminals	1 (RS-485 terminal)	Run command (start, stop)	✓	—	—	✓		—	
		Running frequency setting	✓	—	✓	—		—	
		Monitor	✓	✓	✓	✓		✓	
		Parameter write	✓ <sup>④</sup>	— <sup>⑤</sup>	✓ <sup>④</sup>	✓ <sup>④</sup>		— <sup>⑤</sup>	
		Parameter read	✓	✓	✓	✓		✓	
		Inverter reset	✓	✓	✓	✓		✓	
	Except for 1	Run command (start, stop)	—	—	—	—	✓ <sup>①</sup>	—	
		Running frequency setting	—	—	—	—	✓ <sup>①</sup>	—	
		Monitor	✓	✓	✓	✓	✓	✓	
		Parameter write	— <sup>⑤</sup>	— <sup>⑤</sup>	— <sup>⑤</sup>	— <sup>⑤</sup>	✓ <sup>④</sup>	— <sup>⑤</sup>	
		Parameter read	✓	✓	✓	✓	✓	✓	
		Inverter reset	—	—	—	—	✓ <sup>②</sup>	—	

**Tab. 6-127:** Functions in the single operation modes (1)

Operation Location	Condition (Pr. 551)	Command	Operation Mode					
			PU operation	External operation	External/PU combined operation mode 1 (Pr. 79 = 3)	External/PU combined operation mode 2 (Pr. 79 = 4)	NET operation (when RS-485 terminals are used) <sup>⑥</sup>	NET operation (when communication option is used) <sup>⑦</sup>
Control by communication from communication option	—	Run command (start, stop)	—	—	—	—	—	✓ <sup>①</sup>
		Running frequency setting	—	—	—	—	—	✓ <sup>①</sup>
		Monitor	✓	✓	✓	✓	✓	✓
		Parameter write	— <sup>⑤</sup>	— <sup>⑤</sup>	— <sup>⑤</sup>	— <sup>⑤</sup>	— <sup>⑤</sup>	✓ <sup>④</sup>
		Parameter read	✓	✓	✓	✓	✓	✓
		Inverter reset	—	—	—	—	—	✓ <sup>②</sup>
Control circuit external terminals	—	Inverter reset	✓	✓	✓	✓	✓	
		Run command (start, stop)	—	✓	✓	—	— <sup>①</sup>	
		Frequency setting	—	✓	—	✓	— <sup>①</sup>	

**Tab. 6-127:** Functions in the single operation modes (2)

✓:enabled

—:not enabled

◇:some are enabled

① As set in Pr. 338 "Communication operation command source" and Pr. 339 "Communication speed command source".

② At occurrence of RS-485 communication error, the inverter cannot be reset from the computer.

③ Enabled only when stopped by the PU. At a PU stop, "PS" is displayed on the operation panel. As set in Pr. 75 "Reset selection/disconnected PU detection/PU stop selection". (Refer to section 6.21.1.)

④ Some parameters may be write-disabled according to the Pr. 77 "Parameter write selection" setting and operating status. (Refer to section 6.21.2.)

⑤ Some parameters are write-enabled independently of the operation mode and command source presence/absence. When Pr. 77 = 2, write is enabled. (Refer to Tab. 6-1 for the parameter list.) Parameter clear is disabled.

⑥ When Pr. 550 "NET mode operation command source selection" = 1 (RS-485 terminals valid) or Pr. 550 "NET mode operation command source selection" = 9999 and the communication option is not fitted.

⑦ When Pr. 550 "NET mode operation command source selection" = 0 (communication option valid) or Pr. 550 "NET mode operation command source selection" = 9999 and the communication option is fitted.

**Operation at alarm occurrence**

Alarm Definition	Condition (Pr. 551 setting)	Operation Mode					
		PU operation	External operation	External/PU combined operation mode 1 (Pr. 79 = 3)	External/PU combined operation mode 2 (Pr. 79 = 4)	NET operation (when RS-485 terminals are used) ⑤	NET operation (when communication option is used) ⑥
Inverter fault	—	Stop					
PU disconnection of the PU connector	2 (PU connector)	Stop/continued ① ④					
	1 (RS-485 terminal)	Stop/continued ①					
Communication alarm of PU connector	2 (PU connector)	Stop/continued ②	Continued	Stop/continued ②	Continued		
	1 (RS-485 terminal)	Continued					
Communication alarm of RS-485 terminals	1 (RS-485 terminal)	Stop/continued ②	Continued	Stop/continued ②	Continued		
	2 (PU connector)	Continued				Stop/continued ②	Continued
Communication alarm of USB connector	3 (USB connector)	Stop/continued ②	Continued	Stop/continued ②	Continued		
	Except for 3	Continued					
Communication alarm of communication option	—	Continued				Stop/continued ③	Continued

**Tab. 6-128:** Operation at alarm occurrence

- ① Can be selected using Pr. 75 "Reset selection/disconnected PU detection/PU stop selection"
- ② Can be selected using Pr. 122 "PU communication check time interval" or Pr. 336 "RS-485 communication check time interval"
- ③ As controlled by the communication option.
- ④ In the PU jog operation mode, operation is always stopped when the PU is disconnected. Whether error (E.PUE) occurrence is allowed or not is as set in Pr. 75 "Reset selection/disconnected PU detection/PU stop selection".
- ⑤ When Pr. 550 "NET mode operation command source selection" = 1 (inverter RS-485 terminals valid) or Pr. 550 "NET mode operation command source selection" = 9999 and the communication option is not fitted
- ⑥ When Pr. 550 "NET mode operation command source selection" = 0 (communication option valid) or Pr. 550 "NET mode operation command source selection" = 9999 and the communication option is fitted

### Selection of control source in network operation mode (Pr. 338, Pr. 339)

As control sources, there are the operation command sources that control the signals related to the inverter start command and function selection and the speed command source that controls the signals related to frequency setting.

In network operation mode, the commands from the external terminals and communication (inverter RS-485 terminals or communication option) are as listed below.

Operation Location Selection	Communication operation command source (Pr. 338)		0: NET			1: External			Remarks	
	Communication speed command source (Pr.339)		0: NET	1: External	2: External	0: NET	1: External	2: External		
Fixed function (Terminal-equivalent function)	Running frequency from communication		NET	—	NET	NET	—	NET		
	Terminal 2		—	External	—	—	External	—		
	Terminal 4		—	External		—	External			
	Terminal 1		Compensation							
Selective function Pr. 178 to Pr. 189 setting	0	RL	Low speed operation command/remote setting clear	NET	External		NET	External		Pr. 59 = 0 (multi-speeds) Pr. 59 = 1, 2 (remote) Pr. 270 = "1, 3" (stop-on-contact)
	1	RM	Middle-speed operation command/remote setting deceleration	NET	External		NET	External		
	2	RH	High speed operation command/remote setting acceleration	NET	External		NET	External		
	3	RT	Second function selection	NET			External			Pr. 270 = "1, 3" (stop-on-contact)
	4	AU	Terminal 4 input selection	—	Combined		—	Combined		
	5	JOG	Jog operation selection	—			External			
	6	CS	Selection of automatic restart after instantaneous power failure	External						
	7	OH	External thermal relay input	External						
	8	REX	Fifteen speed selection	NET	External		NET	External		Pr. 59 = 0 (multi-speeds)
	9	X9	Third function selection	NET			External			
	10	X10	Inverter operation enable signal	External						
	11	X11	FR-HC or MT-HC connection, instantaneous power failure detection	External						
	12	X12	PU operation external interlock	External						
	13	X13	External DC injection brake operation is started	NET			External			
	14	X14	PID control valid terminal	NET	External		NET	External		
	15	BRI	Brake opening completion signal	NET			External			
	16	X16	PU-external operation switchover	External						
	17	X17	Load pattern selection forward rotation reverse rotation boost	NET			External			
	18	X18	V/f switching							
19	X19	Load torque high-speed frequency								

**Tab. 6-129:** Writing operation and speed commands (1)

Operation Location Selection	Communication operation command source (Pr. 338)		0: NET			1: External			Remarks		
	Communication speed command source (Pr.339)		0: NET	1: External	2: External	0: NET	1: External	2: External			
Selective function Pr. 178 to Pr. 189 setting	20	X20	S-pattern acceleration/deceleration C switchover		NET	External					
	22	X22	Orientation command								
	23	LX	Pre-excitation								
	24	MRS	Output stop		Combined		External			Pr. 79 ≠ 7	
			PU operation interlock		External						Pr. 79 = 7 When X12 signal is not assigned
	25	STOP	Start self-holding selection		—			External			
	26	MC	Control mode switchover		NET	External					
	27	TL	Torque limit selection								
	28	X28	Start-time tuning start external input								
	37	X37	Traverse function selection								
	42	X42	Torque bias selection 1								
	43	X43	Torque bias selection 2								
	44	X44	P/PI control switchover								
	50	SQ	Sequence start								
	60	STF	Forward rotation command								
	61	STR	Reverse rotation command								
	62	RES	Reset		External						
	63	PTC	PTC thermistor input		External						
	64	X64	PID forward action switchover		NET	External		NET	External		
	65	X65	PU-NET operation switchover		External						
	66	X66	External-NET operation switchover								
67	X67	Command source switchover									
68	NP	Conditional position pulse train sign									
69	CLR	Conditional position droop pulse clear									
70	X70	DC feeding operation permission		NET		External					
71	X71	DC feeding operation cancel									

**Tab. 6-129:** Writing operation and speed commands (2)

Explanation of table:

- External: Operation is valid only from external terminal signal.
- NET: Control only from communication is valid.
- Combined: Operation is valid from either of external terminal and communication.
- : Operation is invalid from either of external terminal and communication.
- Compensation: Control by signal from external terminal is only valid when Pr. 28 "Multi-speed input compensation selection" = 1

**NOTE**

The control source of communication is as set in Pr. 550 and Pr. 551.

**Switching of command source by external terminal (X67)**

In network operation mode, the command source switching signal (X67) can be used to switch the operation command source and speed command source. This signal can be utilized to control the signal input from both the external terminal and communication.

Set "67" to any of Pr. 178 to Pr. 189 to assign the X67 signal to the external terminal.

When the X67 signal is off, the operation command source and speed command source are external.

X67 Signal State	Operation Command Source	Speed Command Source
No signal assignment	According to Pr. 338	According to Pr. 339
ON		
OFF	Operation is valid only from external terminal signal.	

**Tab. 6-130:** Switching of command source by the signal X67

**NOTES**

The ON/OFF state of the X67 signal is reflected only during a stop. It is reflected after a stop when the terminal is switched during operation.

When the X67 signal is off, a reset via communication is disabled.

Changing the terminal assignment using Pr. 178 to Pr. 189 "Input terminal function selection" may affect the other functions. Please make setting after confirming the function of each terminal.

## 6.23 Communication operation and setting

Purpose	Parameters that must be set		Refer to Section
Communication operation from PU connector	Initial setting of computer link communication (PU connector)	Pr. 117–Pr. 124	6.23.3
Communication operation from RS-485 terminal	Initial setting of computer link communication (RS-485 terminal)	Pr. 331–Pr. 337, Pr. 341	
	Modbus-RTU communication specification	Pr. 331, Pr. 332, Pr. 334, Pr. 343, Pr. 549	6.23.6
Restrictions on parameter write through communication	Communication EEPROM write selection	Pr. 342	6.23.4
Operation by PLC function	PLC function	Pr. 414–Pr. 417, Pr. 498, Pr. 506–Pr. 515	6.23.7
Communication using USB (FR-Configurator)	USB communication	Pr. 547, Pr. 548	6.23.8

### 6.23.1 PU connector

Using the PU connector, you can perform communication operation from a personal computer etc. When the PU connector is connected with a personal, FA or other computer by a communication cable, a user program can run and monitor the inverter or read and write to parameters.

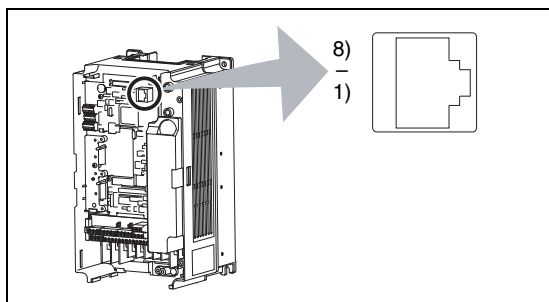

**Fig. 6-211:**  
PU connector pin-outs

1001209E

Pin Number	Name	Description
1)	SG	Earth (Ground) (connected to terminal 5)
2)	—	Operation panel power supply
3)	RDA	Inverter receive+
4)	SDB	Inverter send–
5)	SDA	Inverter send+
6)	RDB	Inverter receive–
7)	SG	Earth (Ground) (connected to terminal 5)
8)	—	Operation panel power supply

**Tab. 6-131:** PU connector (terminal description)

#### NOTES

Pins No. 2) and 8) provide power to the operation panel or parameter unit. Do not use these pins for RS-485 communication.

Do not connect the PU connector to the computer's LAN board, FAX modem socket or telephone modular connector. The product could be damaged due to differences in electrical specifications.



**PU connector communication system configuration and wiring**

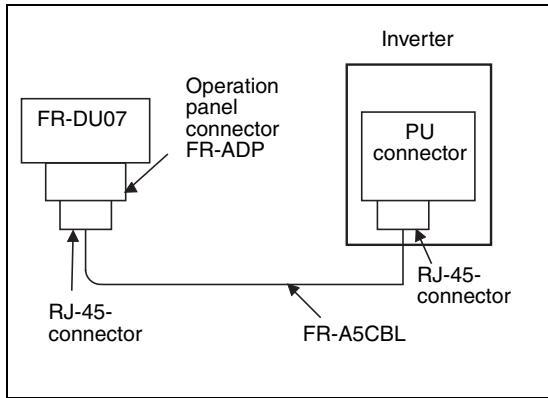

**Fig. 6-212:**  
Connecting the PU to the PU connector

I001210E

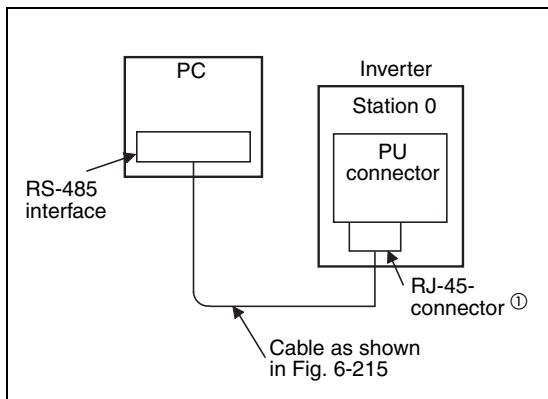

**Fig. 6-213:**  
Connecting the RS-485 interface of a PC to the PU connector

I001211E

① Pins No. 2) and 8) provide power to the operation panel or parameter unit. Do not use these pins for RS-485 communication.

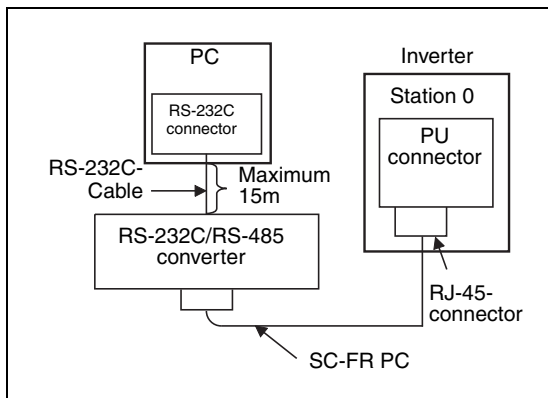

**Fig. 6-214:**  
Connecting the RS-232C interface of a PC to the PU connector

I001212E

**Connection with RS-485 computer**

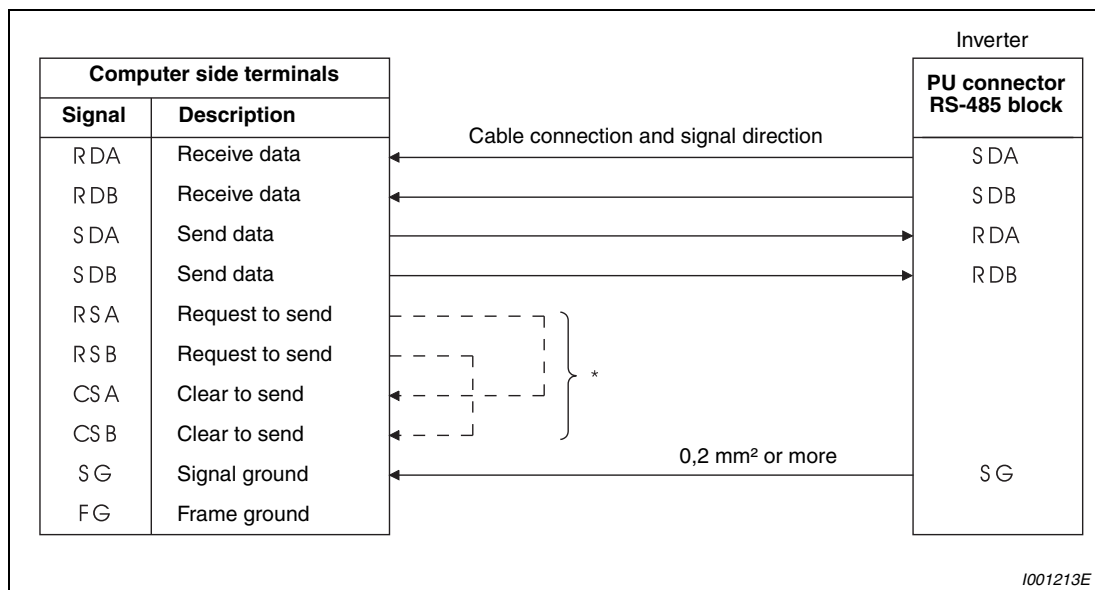

**Fig. 6-215:** Connection to an inverter

\* Make connections in accordance with the manual of the computer used. Fully check the terminal numbers of the computer since they change with the model.

**NOTES**

Use the SC-FR PC cable to connect the RS232C/RS485 converter to the RS232C port of the computer. Note that this cable can only be used for connection of a frequency inverter.

If you need to connect multiple frequency inverters to one another in series use the second serial interface (screw terminals).

### 6.23.2 RS-485 terminals

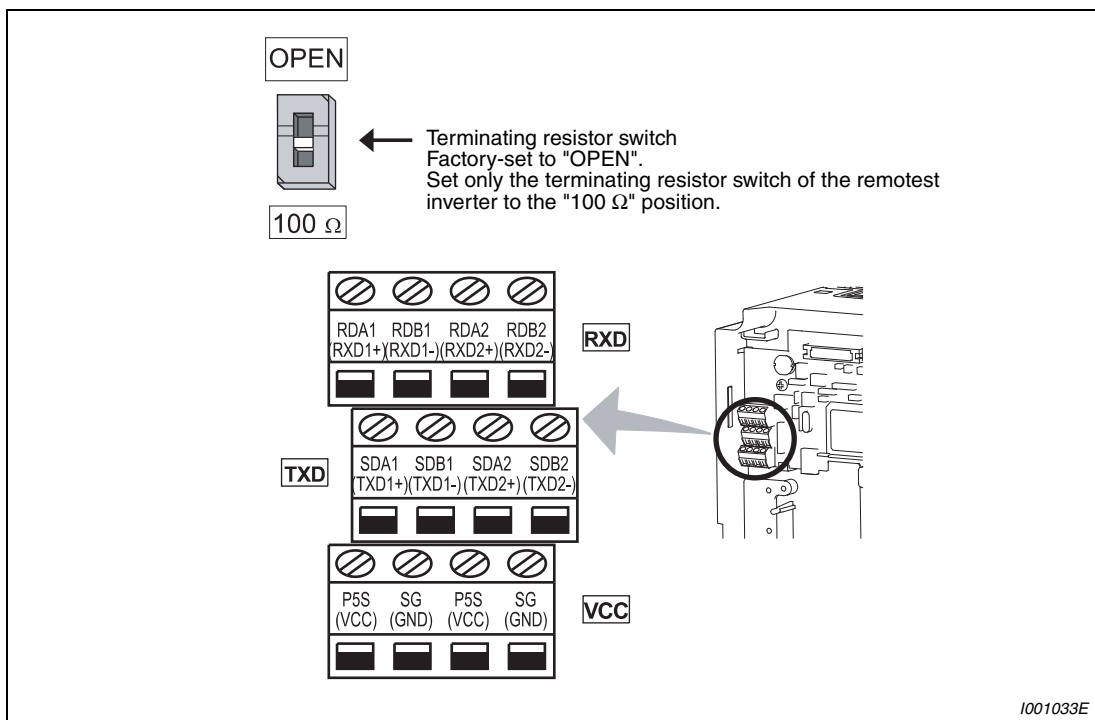

**Fig. 6-216:** RS-485 terminals layout

Name	Description
RDA1 (RXD1+)	Inverter receive+
RDB1 (RXD1-)	Inverter receive-
RDA2 (RXD2+)	Inverter receive+ (for connection of further stations)
RDB2 (RXD2-)	Inverter receive- (for connection of further stations)
SDA1 (TXD1+)	Inverter send+
SDB1 (TXD1-)	Inverter send-
SDA2 (TXD2+)	Inverter send+ (for connection of further stations)
SDB2 (TXD2-)	Inverter send- (for connection of further stations)
PS5 (VCC)	5V power supply, permissible load current: 100mA
SG (GND)	Earth (connected to terminal SD)

**Tab. 6-132:** RS-485 terminal description

**Connection of RS-485 terminals and wires**

- ① Strip about 5mm of the cable insulation. Twist the cable to prevent it from becoming loose. In addition, do not solder it. Use a bar terminal as necessary.

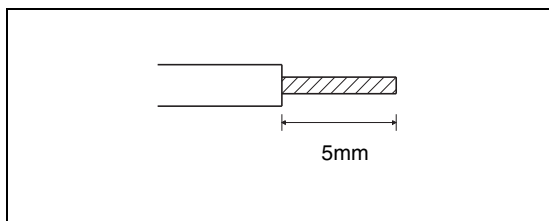

**Fig. 6-217:**  
*Preparing the cable*

1001326E

- ② Loosen the terminal screw and insert the stripped cable into the terminal..

Item	Description
Screws size	M2
Tightening torque	0.22Nm–0.25Nm
Cable size	0.3mm <sup>2</sup> –0.75mm <sup>2</sup>
Screwdriver	Small flat-blade screwdriver Tip dimensions: 0.4mm × 2.5mm

**Tab. 6-133:** *Connection to the RS-485 terminals*



**CAUTION:**  
*Under tightening can cause cable disconnection or malfunction. Over tightening can cause a short circuit or malfunction due to damage to the screw or unit.*

**RS-485 terminal system configuration**

- Connection of a computer to the inverter (1 : 1 connection)

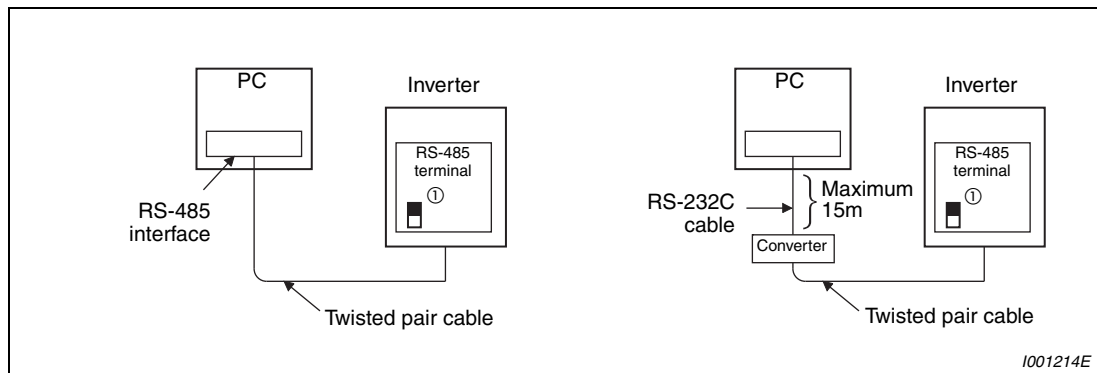

**Fig. 6-218:** Connection of a computer to one inverter

- ① Set the terminating resistor switch to the "100 Ω" position.

- Combination of computer and multiple inverters (1 : n connection)

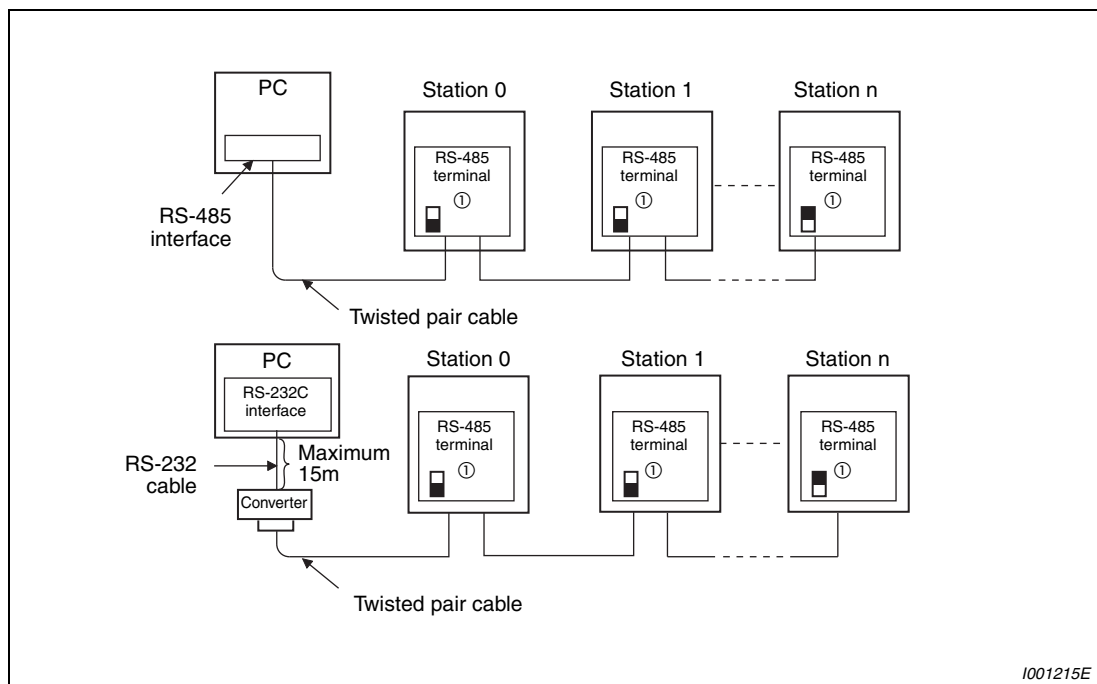
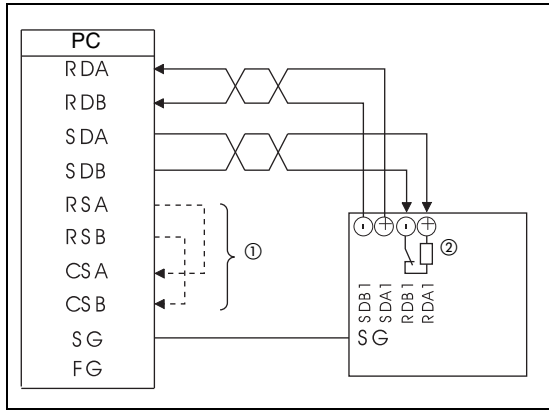

**Fig. 6-219:** Connection of a computer to several inverters

- ① Set only the terminating resistor switch of the remotest inverter to the "100 Ω" position.

**RS-485 terminal wiring method**

- Wiring of one RS-485 computer and one inverter.



**Fig. 6-220:**  
Connection to one inverter

I001216E

- Wiring of one RS-485 computer and "n" inverters (several inverters)

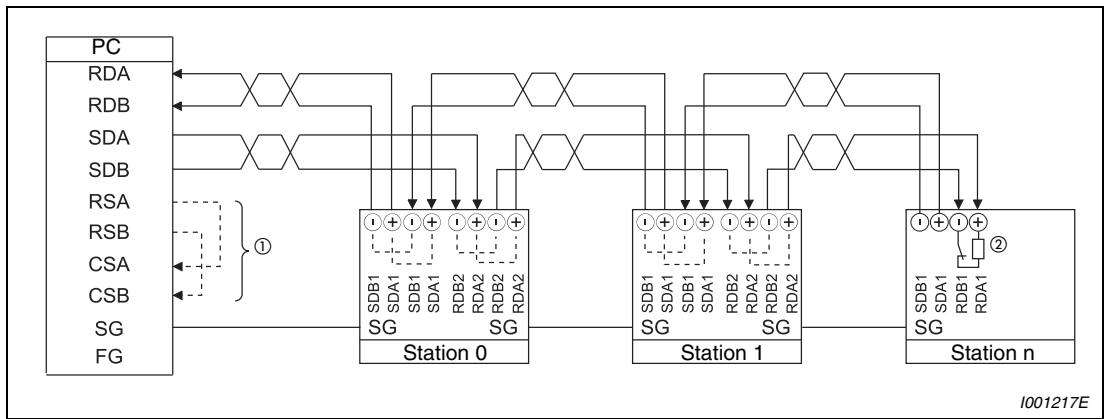

I001217E

**Fig. 6-221:** Connection to several inverter

- ① Make connections in accordance with the manual of the computer used. Fully check the terminal numbers of the computer since they change with the model.
- ② Set only the terminating resistor switch of the remotest inverter to the "100 Ω" position.

**NOTE**

For branching, connect the wires as shown below.

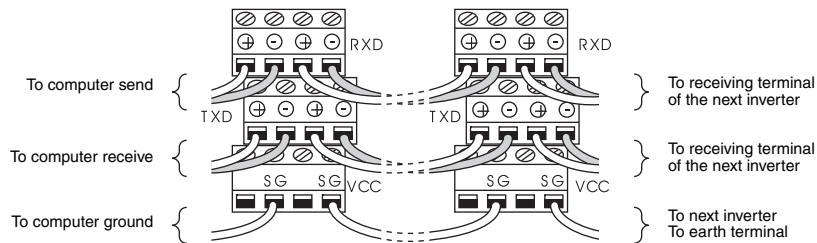

### 2-wire type connection

If the computer is 2-wire type, pass wires across reception terminals and transmission terminals of the RS-485 terminal to enable 2-wire type connection with the inverter.

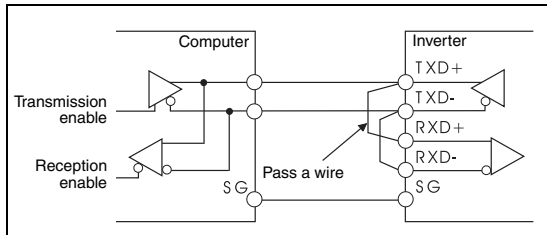

**Fig. 6-222:**  
2-wire type connection

1001219E

#### NOTE

Create a program so that transmission is disabled (receiving state) when the computer is not sending and reception is disabled (sending state) during sending to prevent the computer from receiving its own data.

### 6.23.3 Initial settings and specifications of RS-485 communication (Pr. 117 to Pr. 124, Pr. 331 to Pr. 337, Pr. 341, Pr. 549)

There are two basic types of communications between the inverter and personal computer:

- communication using the PU connector of the inverter
- communication using the RS-485 terminals

You can perform parameter setting, monitor, etc. from the PU connector or RS-485 terminals of the inverter using the Mitsubishi inverter protocol (computer link communication).

To make communication between the personal computer and inverter, initialization of the communication specifications must be made to the inverter. Data communication cannot be made if the initial settings are not made or there is any setting error.

#### PU connector communication related parameter

Pr. No.	Name	Initial Value	Setting Range	Description	
117	PU communication station number	0	0-31	Specify the inverter station number. Set the inverter station numbers when two or more inverters are connected to one personal computer.	
118	PU communication speed	192	48/96/192/384	Set the communication speed. The setting value × 100 equals the communication speed. For example, the communication speed is 19200bps when the setting value is "192".	
119	PU communication stop bit length	1		<b>Stop bit length</b> <b>Data length</b>	
			0	1bit	8bit
			1	2bit	
			10	1bit	7bit
11	2bit				
120	PU communication parity check	2	0	Without parity check	
			1	With odd parity check	
			2	With even parity check	
121	Number of PU communication retries	1	0-10	Set the permissible number of retries at occurrence of a data receive error. If the number of consecutive errors exceeds the permissible value, the inverter will come to an alarm stop.	
			9999	If a communication error occurs, the inverter will not come to an alarm stop.	
122	PU communication check time interval	9999	0	No PU connector communication	
			0.1-999.8s	Set the interval of communication check time. If a no-communication state persists for longer than the permissible time, the inverter will come to an alarm stop.	
			9999	No communication check	
123	PU communication waiting time setting	9999	0-150ms	Set the waiting time between data transmission to the inverter and response.	
			9999	Set with communication data.	
124	PU communication CR/LF presence/absence selection	1	0	Without CR/LF	
			1	With CR	
			2	With CR/LF	

Parameters referred to	Refer to Section
—	



## RS-485 terminal communication related parameter

Pr. No.	Name	Initial Value	Setting Range	Description
<b>331</b>	RS-485 communication station	0	0-31 (0-247) ①	Set the inverter station number. (same specifications as Pr. 117)
<b>332</b>	RS-485 communication speed	96	3/6/12/24/ 48/96/192/ 384	Used to select the communication speed. (same specifications as Pr. 118)
<b>333</b>	RS-485 communication stop bit length ②	1	0/1/10/11	Select stop bit length and data length. (same specifications as Pr. 119)
<b>334</b>	RS-485 communication parity check selection	2	0/1/2	Select the parity check specifications. (same specifications as Pr. 120)
<b>335</b>	RS-485 communication retry count ③	1	0-10/9999	Set the permissible number of retries at occurrence of a data receive error. (same specifications as Pr. 121)
<b>336</b>	RS-485 communication check time interval ③	0 s	0	RS-485 communication can be made, but the inverter will come to an alarm stop in the NET operation mode.
			0.1-999.8s	Set the interval of communication check time. (same specifications as Pr. 122)
			9999	No communication check
<b>337</b>	RS-485 communication waiting time setting ③	9999	0-150ms/ 9999	Set the waiting time between data transmission to the inverter and response. (same specifications as Pr. 123)
<b>341</b>	RS-485 communication CR/LF selection ③	1	0/1/2	Select presence/absence of CR/LF. (same specifications as Pr. 124)
<b>549</b>	Protocol selection	0	0	Mitsubishi inverter (computer link) protocol
			1	Modbus-RTU protocol ④

Parameters referred to	Refer to Section
—	

- ① When "1" (Modbus-RTU protocol) is set in Pr. 549, the setting range within parenthesis is applied.
- ② For the Modbus-RTU protocol, the data length is fixed to 8 bits and the stop bit depends on the Pr. 334 setting. (Refer to section 6.23.6.)
- ③ The Modbus-RTU protocol becomes invalid.
- ④ The Modbus-RTU protocol is valid for only communication from the RS-485 terminals.

## NOTES

If communication is made without Pr. 336 "RS-485 communication check time interval" being changed from "0" (initial value), monitor, parameter read, etc. can be performed, but the inverter results in an alarm as soon as it is switched to the NET operation mode. If the operation mode at power on is the network operation mode, a communication alarm (E.SER) occurs after first communication.

When performing operation or parameter write through communication, set "9999" or more to Pr. 336. (The setting depends on the computer side program.) (Refer to page 6-459.)

Always reset the inverter after making the initial settings of the parameters. After you have changed the communication-related parameters, communication cannot be made until the inverter is reset.

### 6.23.4 Communication EEPROM write selection (Pr. 342)

Parameters written via the inverter's PU connector, RS-485 terminals, or from the communication option can be written to the RAM. Set this parameter when frequent parameter changes are required.

When changing the parameter values frequently, set "1" in Pr. 342 to write them to the RAM. The life of the EEPROM will be shorter if parameter write is performed frequently with the setting unchanged from "0" (initial value) (EEPROM write).

Pr. No.	Name	Initial Value	Setting Range	Description	Parameters referred to	Refer to Section
342	Communication EEPROM write selection	0	0	Parameter values written by communication are written to the EEPROM and RAM.	—	
			1	Parameter values written by communication are written to the RAM.		

The above parameter can be set any time when the communication option is connected. (Refer to section 6.21.4.)

#### NOTE

When Pr. 342 is set to "1" (only RAM write), the new values of the parameters will be cleared at power supply-off of the inverter. Therefore, the parameter values available when power is switched on again are the values stored in EEPROM previously.

### 6.23.5 Mitsubishi inverter protocol (computer link communication)

You can perform parameter setting, monitor, etc. from the PU connector or RS-485 terminals of the inverter using the Mitsubishi inverter protocol (computer link communication).

#### Communication specifications

Item		Description	Related Parameters
Communication protocol		Mitsubishi protocol (computer link)	Pr. 551
Conforming standard		EIA-485 (RS-485)	—
Number of inverters connected		1 : N (maximum 32 units), setting is 0 to 31 stations	Pr. 117 Pr. 331
Communication speed	PU connector	Selected from among 4800/9600/19200 and 38400bps	Pr. 118
	RS-485 terminal	Can be selected from 300, 600, 1200, 2400, 4800, 9600, 19200 and 38400bps	Pr. 332
Control protocol		Asynchronous system	—
Communication method		Half-duplex system	—
Communication specifications	Character system	ASCII (7 bits or 8 bits can be selected)	Pr. 119 Pr. 333
	Start bit	1 bit	—
	Stop bit length	1 bit or 2 bits can be selected	Pr. 119 Pr. 333
	Parity check	Check (even, odd) or no check can be selected	Pr. 120 Pr. 334
	Error check	Sum code check	—
	Terminator	CR/LF (presence or absence can be selected)	Pr. 124 Pr. 341
Waiting time setting		Selectable between presence and absence	Pr. 123 Pr. 337

**Tab. 6-134:** Communication specifications

**Communication procedure**

Data communication between the computer and inverter is made in the following procedure:

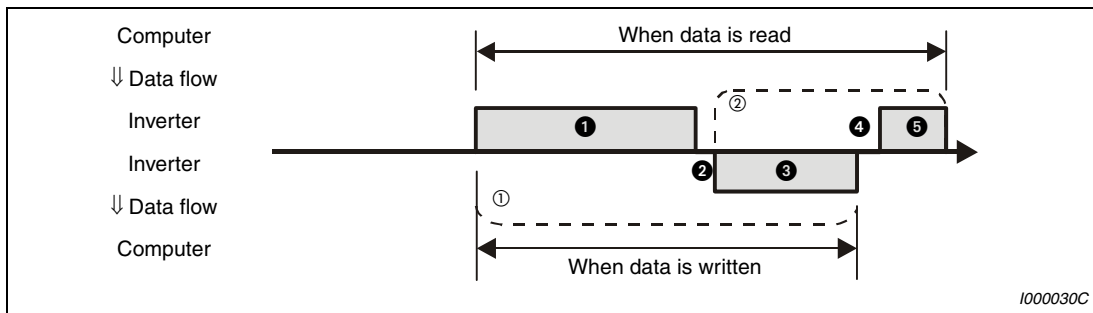

**Fig. 6-223: Schematic diagram of data exchange**

- ① If a data error is detected and a retry must be made, execute retry operation with the user program. The inverter comes to an alarm stop if the number of consecutive retries exceeds the parameter setting.
- ② On receipt of a data error occurrence, the inverter returns "reply data ③" to the computer again. The inverter comes to an alarm stop if the number of consecutive data errors reaches or exceeds the parameter setting.

**Communication operation presence/absence and data format types**

Data communication between the computer and inverter is made in ASCII code (hexadecimal code). Data is automatically converted to ASCII format when it is exchanged between an external computer and the frequency inverter. In the following table the different data formats are referred to with the letters A – F. The corresponding formats are explained in the next section.

No.	Operation	Run Command	Running Frequency	Parameter Write	Inverter Reset	Monitor	Parameter Read
①	Communication request is sent to the inverter in accordance with the user program in the computer.	A A'	A	A	A	B	B
②	The inverter will not send data unless requested.	Present	Present	Present	Absent	Present	Present
③	Reply data from the inverter (Data ①) is checked for error)	No error ① (Request accepted)	C	C	C	C ② E E'	E
		With error (Request rejected)	D	D	D	D ②	D
④	Computer processing delay time	Absent	Absent	Absent	Absent	Absent	Absent
⑤	Answer from computer in response to reply data ③ (Data ③) is checked for error)	No error ① (No inverter processing)	Absent	Absent	Absent	Absent	Absent (C) Absent (C)
		With error (Inverter re-outputs ③)	Absent	Absent	Absent	Absent	F

**Tab. 6-135: Communication and data format**

- ① In the communication request data from the computer to the inverter, 10ms or more is also required after "no data error (ACK)". (Refer to page 6-456.)
- ② The inverter response to the inverter reset request can be selected. (Refer to page 6-462, Tab. 6-140.)

● Communication request data from the computer to the inverter

Format	Number of Characters												
	1	2	3	4	5	6	7	8	9	10	11	12	13
A (Data write)	ENQ ①	Inverter station number ②		Instruction code	Waiting time ③	Data				Sum check	④		
A' (Data write)	ENQ ①	Inverter station number ②		Instruction code	Waiting time ③	Data		Sum check	④				
B (Data read)	ENQ ①	Inverter station number ②		Instruction code	Waiting time ③	Sum check	④						

● Reply data from the inverter to the computer when data is written

Format	Number of Characters				
	1	2	3	4	5
C (No data error detected)	ACK ①	Inverter station number ②		④	
D (Data error detected)	NAK ①	Inverter station number ②		Error code	④

● Reply data from the inverter to the computer when data is read

Format	Number of Characters										
	1	2	3	4	5	6	7	8	9	10	11
E (No data error detected)	STX ①	Inverter station number ②		Read data				ETX ①	Sum check	④	
E' (No data error detected)	STX ①	Inverter station number ②		Read data	ETX ①	Sum check	④				
D (Data error detected)	NAK ①	Inverter station number ②		Error code	④						

● Send data from the computer to the inverter during data read

Format	Number of Characters			
	1	2	3	4
C (No data error detected)	ACK ①	Inverter station number ②		④
F (Data error detected)	NAK ①	Inverter station number ②		④

- ① Indicate a control code (Refer to Tab. 6-136.)
- ② Specify the inverter station numbers between H00 and H1F (stations 0 to 31) in hexadecimal.
- ③ When Pr. 123, Pr. 337 "Waiting time setting" ≠ 9999, create the communication request data without "waiting time" in the data format. (The number of characters decreases by 1.)
- ④ CR, LF code  
When data is transmitted from the computer to the inverter, CR (carriage return) and LF (line feed) codes are automatically set at the end of a data group on some computers. In this case, setting must also be made on the inverter according to the computer. Whether the CR and LF codes will be present or absent can be selected using Pr. 124 or Pr. 341 "CR, LF presence/absence selection".

**Data definitions**

● Control codes

Signal Name	ASCII Code	Description
STX	H02	Start Of Text (start of data)
ETX	H03	End Of Text (end of data)
ENQ	H05	Enquiry (communication request)
ACK	H06	Acknowledge (no data error detected)
LF	H0A	Line Feed
CR	H0D	Carriage Return
NAK	H15	Negative Acknowledge (data error detected)

**Tab. 6-136:** Control codes

● Inverter station number

Specify the station number of the inverter which communicates with the computer.

The inverter station numbers are specified between H00 and H1F (stations 0 to 31) in hexadecimal.

● Instruction code

Specify the processing request, e.g. operation or monitoring, given by the computer to the inverter. Hence, the inverter can be run and monitored in various ways by specifying the instruction code as appropriate. (Refer to the appendix.)

● Data

Indicates the data such as frequency and parameters transferred to and from the inverter. The definitions and ranges of set data are determined in accordance with the instruction codes. (Refer to the appendix.)

● Waiting time

Specify the waiting time between the receipt of data at the inverter from the computer and the transmission of reply data. Set the waiting time in accordance with the response time of the computer between 0 and 150ms in 10ms increments (e.g. 1 = 10ms, 2 = 20ms).

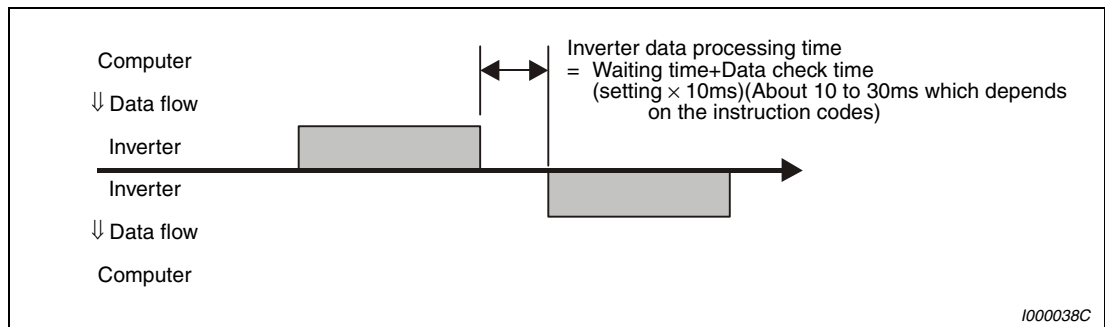

**Fig. 6-224:** Specifying the waiting time

**NOTES**

When Pr. 123, Pr. 337 "Waiting time setting" ≠ 9999, create the communication request data without "waiting time" in the data format. (The number of characters decreases by 1.)

The data check time changes depending on the instruction code. (Refer to page 6-457.)

- Sum check code  
The sum check code is 2-digit ASCII (hexadecimal) representing the lower 1 byte (8 bits) of the sum (binary) derived from the checked ASCII data.

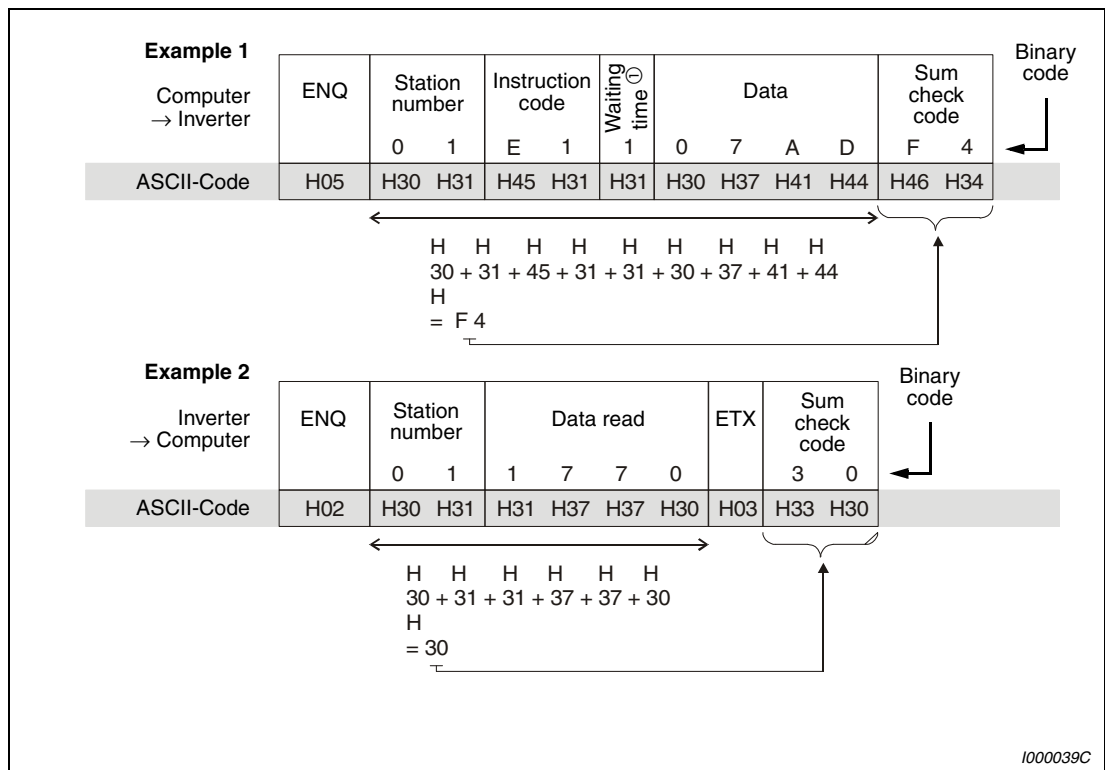

**Fig. 6-225: Sum check code (examples)**

- ① When Pr. 123, Pr. 337 "Waiting time setting" ≠ 9999, create the communication request data without "waiting time" in the data format. (The number of characters decreases by 1.)

- Error code

If any error is found in the data received by the inverter, its definition is sent back to the computer together with the NAK code.

Error Code	Error Item	Error Definition	Inverter Operation
H0	Computer NAK error	The number of errors consecutively detected in communication request data from the computer is greater than allowed number of retries.	Brought to an alarm stop if error occurs continuously more than the allowable number of retries. (E.PUE/E.SER)
H1	Parity error	The parity check result does not match the specified parity.	
H2	Sum check error	The sum check code in the computer does not match that of the data received by the inverter.	
H3	Protocol error	The data received by the inverter has a grammatical mistake. Alternatively, data receive is not completed within the predetermined time. CR or LF is not as set in the parameter.	
H4	Framing error	The stop bit length differs from the initial setting.	
H5	Overrun error	New data has been sent by the computer before the inverter completes receiving the preceding data.	
H6	—	—	—
H7	Character error	The character received is invalid (other than 0 to 9, A to F, control code).	Does not accept received data but is not brought to alarm stop.
H8	—	—	—
H9	—	—	—
HA	Mode error	Parameter write was attempted in other than the computer link operation mode, when operation command source is not selected or during inverter operation.	Does not accept received data but is not brought to alarm stop.
HB	Instruction code error	The specified command does not exist.	
HC	Data range error	Invalid data has been specified for parameter write, frequency setting, etc.	
HD	—	—	—
HE	—	—	—
HF	—	—	—

**Tab. 6-137: Error codes**



● Response time

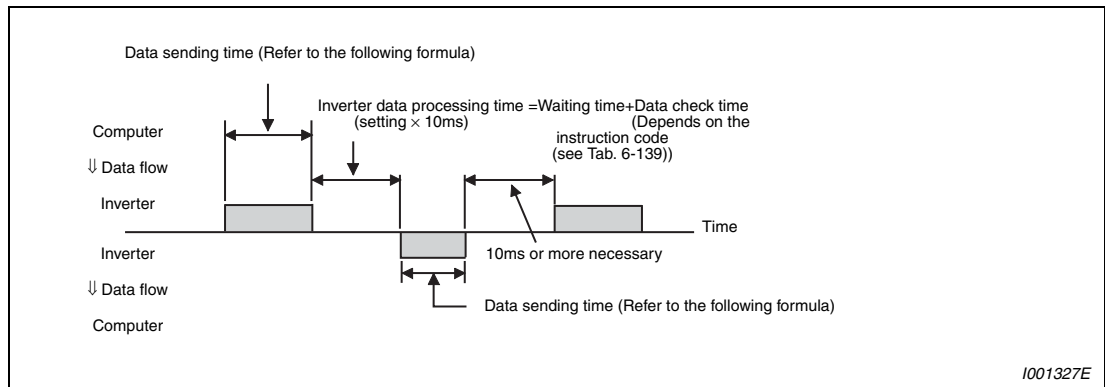

**Fig. 6-226: Response time**

Formula for data sending time:

$$\text{Data sending time [s]} = \frac{1}{\text{Communication speed (Baudrate)}} \times \text{Number of data characters (refer to page 6-453)} \times \text{Communications specifications (total number of bits)} \text{①}$$

① The communication specifications are listed in the table below:

Name		Number of Bits
Stop bit length		1 bit
		2 bits
Data length		7 bit
		8 bits
Parity check	Yes	1 bit
	No	0 bits

**Tab. 6-138: Communication specifications**

**NOTES**

In addition to the above, 1 start bit is necessary.

Minimum number of total bits: 9 bits. Maximum number of total bits: 12 bits.

The data check time related to different functions is shown in the table below:

Function	Data Check Time
Various monitors, run command, frequency setting (RAM)	< 12ms
Parameter read/write, frequency setting (EEPROM)	< 30ms
Parameter clear/all clear	< 5s
Reset command	— (no answer)

**Tab. 6-139: Data check time**

**Retry count setting (Pr. 121, Pr. 335)**

Set the permissible number of retries at occurrence of a data receive error. (Refer to page 6-456 for data receive error for retry.)

When data receive errors occur consecutively and exceed the permissible number of retries set, an inverter alarm (E.PUE) is provided and the output is shut off.

When "9999" is set, an inverter alarm is not provided even if data receive error occurs but a minor fault output signal (LF) is output. For the terminal used for the LF signal output, assign the function by setting "98 (source logic) or 198 (sink logic)" in any of Pr. 190 to Pr. 196 "Output terminal function selection".

**Example ▾**

**PU connector communication with different settings of paramter 121**

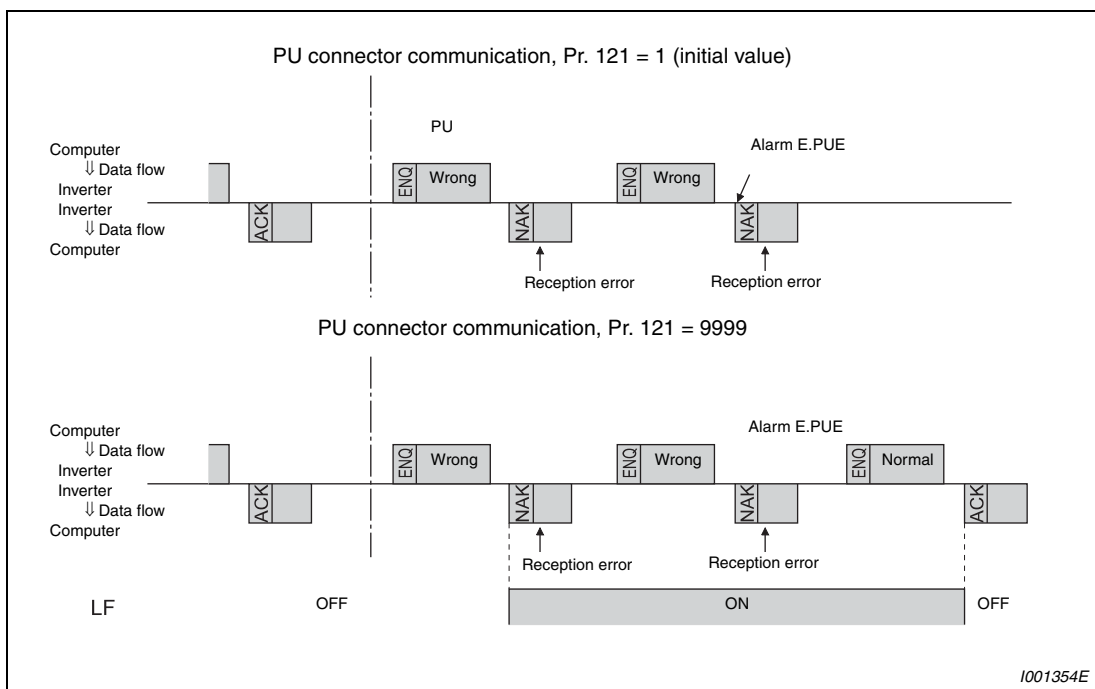

**Fig. 6-227: Data transmission error**



### Open cable detection (Pr. 122, Pr. 336)

If disconnection (communication stop) is detected between the inverter and computer as a result of disconnection check, a communication error (PU connector communication: E.PUE, RS-485 terminal communication: E.SER) occurs and the inverter output is shut off.

Disconnection check is made when the setting is any of "0.1s" to "999.8s". To make disconnection check, it is necessary to send data (control code refer to page 6-454) from the computer within the communication check time interval. (The send data has nothing to do with the station number)

Communication check is started at the first communication in the operation mode having the operation source (PU operation mode for PU connector communication in the initial setting or network operation mode for RS-485 terminal communication).

When the setting is "9999", communication check (disconnection detection) is not made.

When the setting is "0", communication from the PU connector cannot be performed. For communication via the RS-485 terminals, monitor, parameter read, etc. can be performed, but a communication error (E.SER) occurs as soon as the inverter is switched to network operation mode.

#### Example ▾

PU connector communication, Pr. 122 = 0,1–999.8s

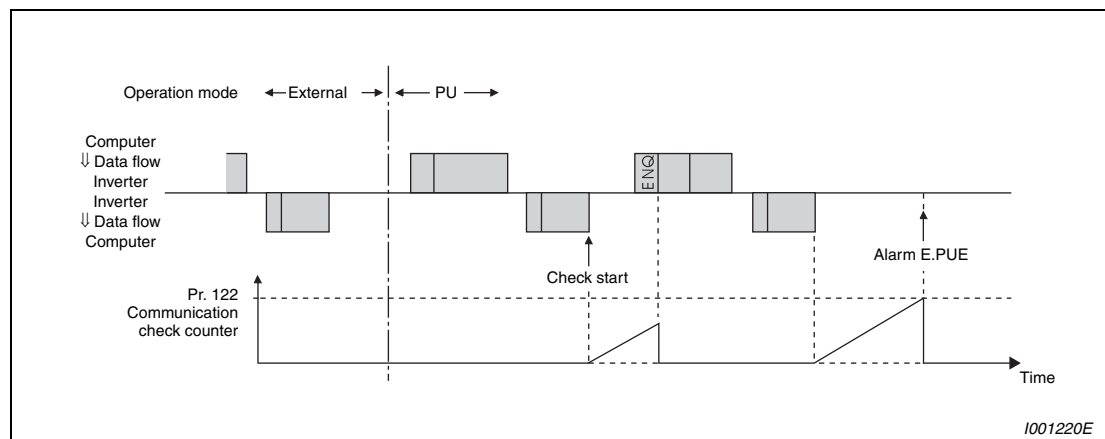

Fig. 6-228: Open cable detection



**Instructions for the program**

When data from the computer has any error, the inverter does not accept that error. Hence, in the user program, always insert a retry program for data error.

All data communication, e.g. run command or monitoring, are started when the computer gives a communication request. The inverter does not return any data without the computer's request. Hence, design the program so that the computer gives a data read request for monitoring, etc. as required.

**Program example**

To change the operation mode to computer link operation:

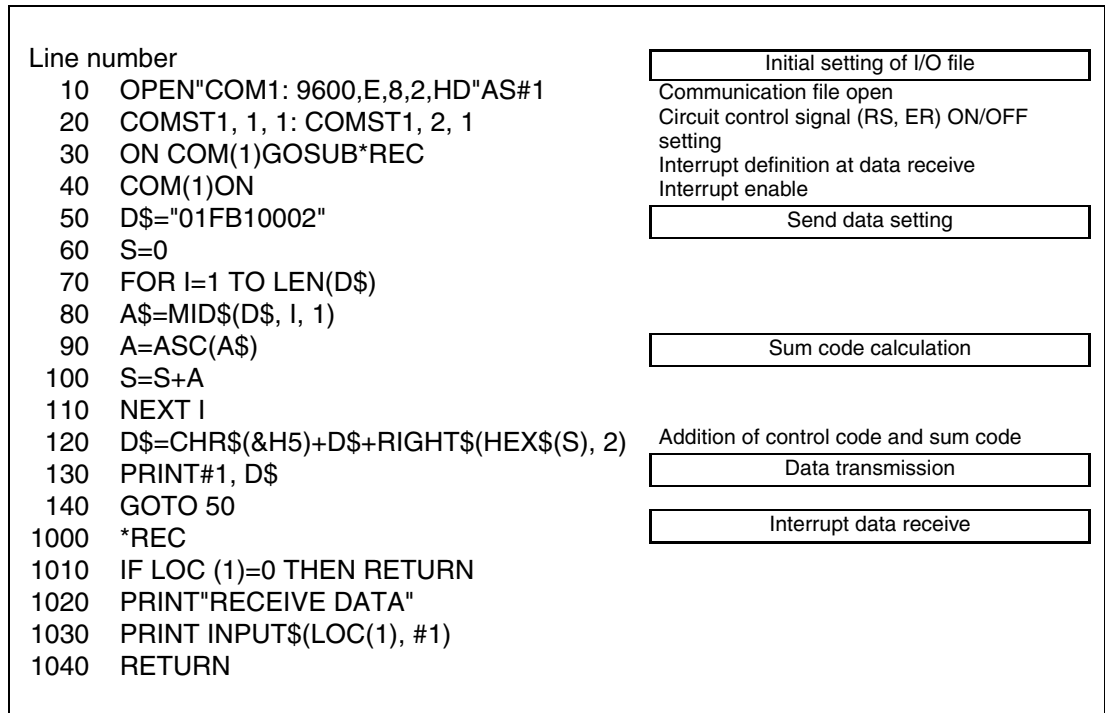

**Fig. 6-229: Program example**

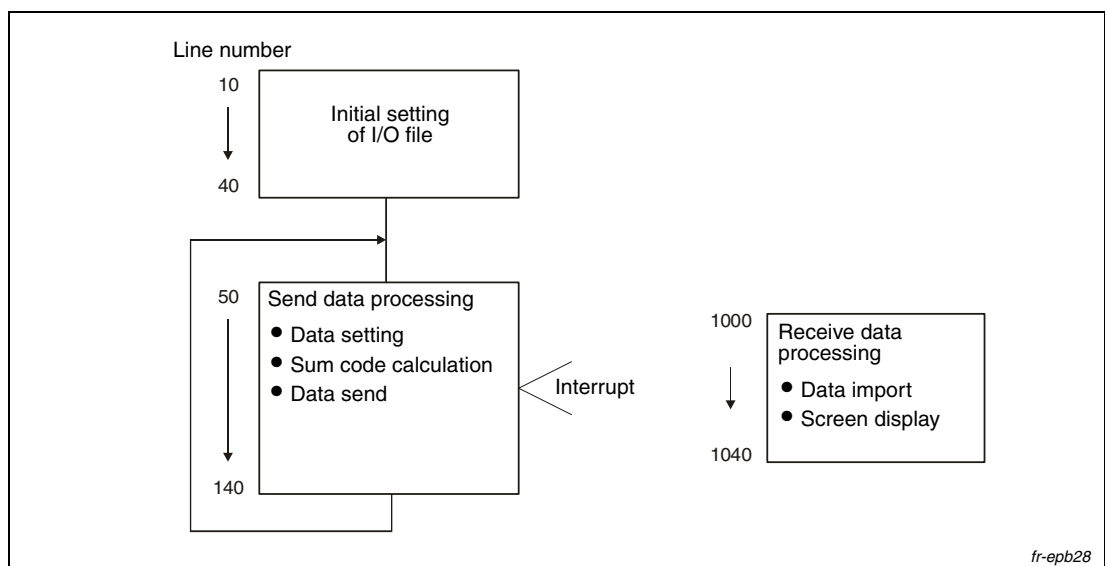

**Fig. 6-230: General flow**

**NOTES**

Always set the communication check time interval before starting operation to prevent hazardous conditions.

Data communication is not started automatically but is made only once when the computer provides a communication request. If communication is disabled during operation due to signal cable breakage etc., the inverter cannot be stopped. When the communication check time interval has elapsed, the inverter will come to an alarm stop (E.PUE, E.SER). The inverter can be coasted to a stop by switching on its RES signal or by switching power off.

If communication is broken due to signal cable breakage, computer fault etc., the inverter does not detect such a fault. This should be fully noted.

**Setting items and set data**

After completion of parameter setting, set the instruction codes and data then start communication from the computer to allow various types of operation control and monitoring.

No.	Item	Read/write	Instruction Code	Data Description	Number of Data Digits (Format)														
1	Operation Mode	Read	H7B	H000:Network operation H0001:External operation H0002:PU operation (RS-485 communication operation via PU connector)	4 (B.E/D)														
		Write	HFB		4 (A, C/D)														
2	Monitor	Output frequency/speed	Read	H6F	H0000 to HFFFF: Output frequency in 0.01Hz increments Speed in 1r/min increments (when Pr. 37 = 1 to 9998 or Pr. 144 = 2 to 10, 102 to 110)	4 (B.E/D)													
		Output current	Read	H70	H0000 to HFFFF: Output current (hexadecimal) in 0.01A increments (01160 or less)/0.1A increments (01800 or more)	4 (B.E/D)													
		Output voltage	Read	H71	H0000 to HFFFF: Output voltage (hexadecimal) in 0.1V increments	4 (B.E/D)													
		Special monitor	Read	H72	H0000 to HFFFF: Monitor data selected in instruction code HF3	4 (B.E/D)													
		Special monitor selection No.	Read	H73	H01 to H36: Monitor selection data (Refer to Tab. 6-143 on page 6-466.)	2 (B.E/D)													
			Write	HF3		2 (A', C/D)													
Alarm definition	Read	H74 to H77	H0000 to HFFFF:  <table border="1" style="margin-left: 20px;"> <tr> <td style="text-align: center;">b15</td> <td style="text-align: center;">b8 b7</td> <td style="text-align: center;">b0</td> </tr> <tr> <td>H74</td> <td>Second alarm in past      Latest Alarm</td> <td></td> </tr> <tr> <td>H75</td> <td>Fourth alarm in past      Third alarm in past</td> <td></td> </tr> <tr> <td>H76</td> <td>Sixth alarm in past      Fifth alarm in past</td> <td></td> </tr> <tr> <td>H77</td> <td>Eighth alarm in past      Seventh alarm in</td> <td></td> </tr> </table> (Refer to Tab. 6-144 on page 6-467.)	b15	b8 b7	b0	H74	Second alarm in past      Latest Alarm		H75	Fourth alarm in past      Third alarm in past		H76	Sixth alarm in past      Fifth alarm in past		H77	Eighth alarm in past      Seventh alarm in		4 (B.E/D)
b15	b8 b7	b0																	
H74	Second alarm in past      Latest Alarm																		
H75	Fourth alarm in past      Third alarm in past																		
H76	Sixth alarm in past      Fifth alarm in past																		
H77	Eighth alarm in past      Seventh alarm in																		
3	Run command (extended)	Write	HF9	You can set the control input commands such as the forward rotation signal (STF) and reverse rotation signal (STR). (Refer to page 6-468 for details.)	4 (A, C/D)														
	Run command	Write	HFA		2 (A', C/D)														
4	Inverter status monitor (extended)	Read	H79	You can monitor the states of the output signals such as forward rotation, reverse rotation and inverter running (RUN). (Refer to page 6-468 for details.)	4 (B.E/D)														
	Inverter status monitor	Read	H7A		2 (B.E/D)														

**Tab. 6-140: Setting of the instruction codes and data (1)**

No.	Item	Read/write	Instruction Code	Data Description	Number of Data Digits (Format)																									
5	Set frequency (RAM)	Read	H6D	Read the set frequency/speed from the RAM or EEPROM. H0000 to HFFFF: Set frequency in 0.01Hz increments Speed in 1r/min increments (When Pr. 37 = 1 to 9998 or Pr. 144 = 2 to 10, 102 to 110)	4 (B,E/D)																									
	Set frequency (EEPROM)		H6E																											
	Set frequency (RAM)	Write	HED	Write the set frequency/speed into the RAM or EEPROM. H0000 to H9C40 (0 to 400.00Hz): frequency in 0.01Hz increments H0000 to H270E (0 to 9998): speed in 1r/min increments (when Pr. 37 = 1 to 9998 or Pr. 144 = 2 to 10, 102 to 110) To change the running frequency consecutively, write data to the inverter RAM. (Instruction code: HED)	4 (A, C/D)																									
	Set frequency (RAM, EEPROM)		HEE																											
6	Inverter reset	Write	HFD	H9696: Resets the inverter. As the inverter is reset at start of communication by the computer, the inverter cannot send reply data back to the computer.	4 (A, C/D)																									
				H9666: Resets the inverter. When data is sent normally, ACK is returned to the computer and then the inverter is reset.	4 (A, D)																									
7	Alarm definition all clear	Write	HF4	H9696: Alarm history batch clear	4 (A, C/D)																									
8	All parameter clear	Write	HFC	<p>All parameters return to the initial values. Any of four different all clear operations are performed according to the data:</p> <table border="1"> <thead> <tr> <th>Data</th> <th>Comm.-Param. ①</th> <th>Calibration ②</th> <th>Other Param. ③</th> <th>HEC HF3 HFF</th> </tr> </thead> <tbody> <tr> <td>H9696</td> <td>✓</td> <td>—</td> <td>✓</td> <td>✓</td> </tr> <tr> <td>H9966</td> <td>✓</td> <td>✓</td> <td>✓</td> <td>✓</td> </tr> <tr> <td>H5A5A</td> <td>—</td> <td>—</td> <td>✓</td> <td>✓</td> </tr> <tr> <td>H55AA</td> <td>—</td> <td>✓</td> <td>✓</td> <td>✓</td> </tr> </tbody> </table> <p>When all parameter clear is executed for H9696 or H9966, communication-related parameter settings also return to the initial values. When resuming operation, set these parameters again.</p> <p>① Refer to page 6-448 and 6-449. ② Refer to page 6-385. ③ Pr. 73 is not cleared.</p>	Data	Comm.-Param. ①	Calibration ②	Other Param. ③	HEC HF3 HFF	H9696	✓	—	✓	✓	H9966	✓	✓	✓	✓	H5A5A	—	—	✓	✓	H55AA	—	✓	✓	✓	4 (A, C/D)
Data	Comm.-Param. ①	Calibration ②	Other Param. ③	HEC HF3 HFF																										
H9696	✓	—	✓	✓																										
H9966	✓	✓	✓	✓																										
H5A5A	—	—	✓	✓																										
H55AA	—	✓	✓	✓																										
9	Parameters	Read	H00 to H63	Refer to the instruction code of the parameter list (appendix) and write and/or read the values as required. When setting Pr. 100 and later, link parameter expansion setting must be set.	4 (B,E/D)																									
10		Write	H80 to HE3		4 (A, C/D)																									

**Tab. 6-140:** Setting of the instruction codes and data (2)

No.	Item	Read/write	Instruction Code	Data Description	Number of Data Digits (Format)
11	Link parameter extended setting	Read	H7F	parameter description is changed according to the H00 to H09 setting. For details of the setting, refer to the instruction code of the parameter list (appendix).	2 (B,E'/D)
		Write	HFF		2 (A', C/D)
12	Second parameter changing (instruction code HFF = 1)	Read	H6C	When setting the bias/gain (instruction codes H5E to H61, HDE to HE1) parameters: H00: Frequency ① H01: Parameter-set analog value (%) H02: Analog value input from terminal ①The gain frequency can also be written using Pr. 125 (instruction code H99) or Pr. 126 (instruction code H9A).	2 (B,E'/D)
		Write	HEC		2 (A', C/D)

**Tab. 6-140:** Setting of the instruction codes and data (3)

**NOTES**

Refer to page 6-453 for data formats A, A', B, B', C und D.

Set 65520 (HFFF0) as a parameter value "8888" and 65535 (HFFFF) as "9999".

For the instruction codes HFF, HEC and HF3, their values are held once written but cleared to zero when an inverter reset or all clear is performed.

**Example** ▽

When reading the C3 (Pr. 902) and C6 (Pr. 904) settings from the inverter of station No. 0.

	Computer Send Data	Inverter Send Data	Description
①	ENQ 00 FF 0 01 82	ACK 00	Set "H01" to the extended link parameter.
②	ENQ 00 EC 0 01 7E	ACK 00	Set "H01" to second parameter changing.
③	ENQ 00 5E 0 0F	STX 00 0000 ETX 25	C3 (Pr. 902) is read. 0% is read.
④	ENQ 00 60 0 FB	STX 00 0000 ETX 25	C6 (Pr. 904) is read. 0% is read.

**Tab. 6-141:** Example for data transmission

To read/write C3 (Pr. 902) and C6 (Pr. 904) after inverter reset or parameter clear, execute from step ① again.





● List of calibration parameters

Pr.	Name	Instruction code			Pr.	Name	Instruction code		
		Read	Write	Extended			Read	Write	Extended
C2 (902)	Terminal 2 frequency setting bias frequency	5E	DE	1	C12 (917)	Terminal 1 bias frequency (speed)	11	91	9
C3 (902)	Terminal 2 frequency setting bias	5E	DE	1	C13 (917)	Terminal 1 bias (speed)	11	91	9
125 (903)	Terminal 2 frequency setting gain frequency	5F	DF	1	C14 (918)	Terminal 1 gain frequency (speed)	12	92	9
C4 (903)	Terminal 2 frequency setting gain	5F	DF	1	C15 (918)	Terminal 1 gain (speed)	12	92	9
C5 (905)	Terminal 4 frequency setting bias frequency	60	E0	1	C16 (919)	Terminal 1 bias command (torque/magnetic flux)	13	93	9
C6 (904)	Terminal 4 frequency setting bias	60	E0	1	C17 (919)	Terminal 1 bias (torque/magnetic flux)	13	93	9
126 (905)	Terminal 4 frequency setting gain frequency	61	E1	1	C18 (920)	Terminal 1 gain command (torque/magnetic flux)	14	94	9
C7 (905)	Terminal 4 frequency setting gain	61	E1	1	C19 (920)	Terminal 1 gain (torque/magnetic flux)	14	94	9
C8 (930)	Current output bias signal	1E	9E	9	C38 (932)	Terminal 4 bias command (torque/magnetic flux)	20	A0	9
C9 (930)	Current output bias current	1E	9E	9	C39 (932)	Terminal 4 bias (torque/magnetic flux)	20	A0	9
C10 (931)	Current output gain signal	1F	9F	9	C40 (933)	Terminal 4 gain command (torque/magnetic flux)	21	A1	9
C11 (931)	Current output gain current	1F	9F	9	C41 (933)	Terminal 4 gain (torque/magnetic flux)	21	A1	9

**Tab. 6-142:** Calibration parameters

- Special monitor selection No.  
Refer to section 6.15.2 for details of the monitor description.

Data	Description	Unit	Data	Description	Unit
H01	Output frequency	0.01Hz	H14	Cumulative energizing time	1h
H02	Output current	0.01A/ 0.1A <sup>①</sup>	H16	Orientation status	—
H03	Output voltage	0.1V	H17	Actual operation time	1h
H05	Frequency setting	0.01Hz	H18	Motor load factor	0.1%
H06	Running speed	1r/min	H19	Cumulative power	1kWh
H07	Motor torque	0.1%	H20	Torque command	0.1%
H08	Converter output voltage	0.1V	H21	Torque current command	0.1%
H09	Regenerative brake duty	0.1%	H22	Motor output	0.01kW/ 0.1kW <sup>①</sup>
H0A	Electronic thermal relay function load factor	0.1%	H23	Feedback pulse	—
H0B	Output current peak value	0.01A/ 0.1A <sup>①</sup>	H32	Power saving effect	Variable
H0C	Converter output voltage peak value	0.1V	H33	Cumulative saving power	Variable
H0D	Input power	0.01kW/ 0.1kW <sup>①</sup>	H34	PID set point	0.1%
H0E	Output power	0.01kW/ 0.1kW <sup>①</sup>	H35	PID measurement value	0.1%
H0F	Input terminal status <sup>②</sup>	—	H36	PID deviation value	0.1%
H10	Output terminal status <sup>③</sup>	—	H3A	Option input terminal status 1 <sup>④</sup>	—
H11	Load meter	0.1%	H3B	Option input terminal status 2 <sup>⑤</sup>	
H12	Motor excitation current	0.01A/ 0.1A <sup>①</sup>	H3C	Option output terminal status <sup>⑥</sup>	
H13	Position pulse	—	—	—	—

**Tab. 6-143: Special monitor selection No.**

① The setting depends on capacities. (01800 or less / 02160 or more)

② Input terminal monitor details

b15														b0		
—	—	—	—	CS	RES	STOP	MRS	JOG	RH	RM	RL	RT	AU	STR	STF	

③ Output terminal monitor details

b15														b0		
—	—	—	—	—	—	—	—	—	ABC2	ABC1	FU	OL	IPF	SU	RUN	

④ Details of option input terminal monitor 1 (input terminal status of FR-A7AX)-all terminals are off when an option is not fitted

b15															b0
X15	X14	X13	X12	X11	X10	X9	X8	X7	X6	X5	X4	X3	X2	X1	X0

⑤ Details of option input terminal monitor 2 (input terminal status of FR-A7AX)-all terminals are off when an option is not fitted

b15															b0
—	—	—	—	—	—	—	—	—	—	—	—	—	—	—	DY

⑥ Details of option output terminal monitor (output terminal status of FR-A7AY/A7AR)-all terminals are off when an option is not fitted

b15															b0
—	—	—	—	—	—	RA3	RA2	RA1	Y6	Y5	Y4	Y3	Y2	Y1	Y0

- Alarm data  
Refer to section 7.1 for details of alarm description.

Data	Description	Data	Description	Data	Description
H00	No alarm	H91	E.PTC	HD3	E.OD
H10	E.OC1	HA0	E.OPT	HD5	E.MB1
H11	E.OC2	HA3	E.OP3	HD6	E.MB2
H12	E.OC3	HB0	E.PE	HD7	E.MB3
H20	E.OV1	HB1	E.PUE	HD8	E.MB4
H21	E.OV2	HB2	E.RET	HD9	E.MB5
H22	E.OV3	HB3	E.PE2	HDA	E.MB6
H30	E.THT	HC0	E.CPU	HDB	E.MB7
H31	E.THM	HC1	E.CTE	HDC	E.EP
H40	E.FIN	HC2	E.P24	HF1	E.1
H50	E.IPF	HC4	E.CDO	HF2	E.2
H51	E.UVT	HC5	E.IOH	HF3	E.3
H52	E.ILF	HC6	E.SER	HF6	E.6
H60	E.OLT	HC7	E.AIE	HF7	E.7
H70	E.BE	HC8	E.USB	HFB	E.11
H80	E.GF	HD0	E.OS	HFD	E.13
H81	E.LF	HD1	E.OSD	—	—
H90	E.OHT	HD2	E.ECT	—	—

**Tab. 6-144:** Alarm data

**Example** ▾

Alarm description display example (instruction code: H74)

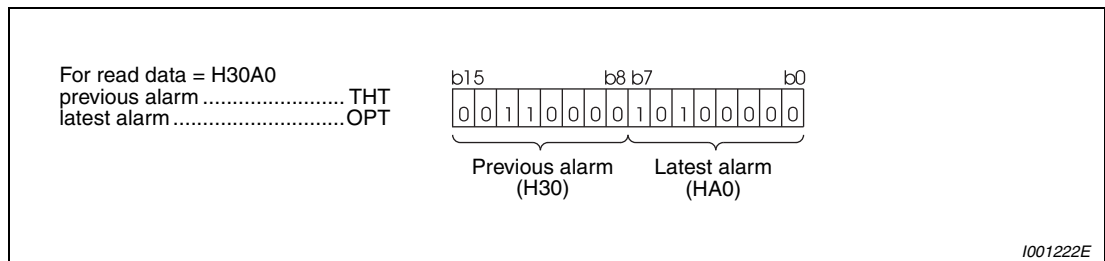

**Fig. 6-231:** Alarm example



● Run command

Item	Instruction Code	Bits	Description	Example
Run command	HFA	8	b0: AU (current input selection) ① b1: Forward rotation start b2: Reverse rotation start b3: RL (low speed) ① b4: RM (middle speed) ① b5: RH (high speed) ① b6: RT (second function selection) ① b7: MRS (output stop) ①	Example 1: H02 (Forward rotation) b7 b0 0 0 0 0 0 0 1 0 Example 2: H00 (Stop) b7 b0 0 0 0 0 0 0 0 0
Run command (extended)	HF9	16	b0: AU (current input selection) ① b1: Forward rotation start b2: Reverse rotation start b3: RL (low speed) ① b4: RM (middle speed) ① b5: RH (high speed) ① b6: RT (second function selection) ① b7: MRS (output stop) ① b8: JOG (Jog operation) ② b9: CS (automatic restart after instantaneous power failure) ② b10: STOP (start self-holding) ② b11: RES (reset) ② b12: — b13: — b14: — b15: —	Example 1: H0002 (Forward rotation) b15 b0 0 0 0 0 0 0 0 0 0 0 0 0 0 0 1 0 Example 2: H0800 low speed operation (When Pr. 189 "RES terminal function selection" is set to "0") b15 b0 0 0 0 0 1 0 0 0 0 0 0 0 0 0 0 0

**Tab. 6-145: Run commands**

- ① The signal within parentheses is the initial setting. The description changes depending on the setting of Pr. 180 to Pr. 184 and Pr. 187 "Input terminal function selection". (Refer to section 6.14.1.)
- ② The signal within parentheses is the initial setting. Since jog operation/selection of automatic restart after instantaneous power failure/start self-holding/reset cannot be controlled by the network, bit 8 to bit 11 are invalid in the initial status. When using bit 8 to bit 11, change the signals with Pr. 185, Pr. 186, Pr. 188, Pr. 189 "Input terminal function selection" (section 6.14.1). (Reset can be executed with the instruction code HFD.)

● Inverter status monitor

Item	Instruction Code	Bits	Description	Example
Inverter status monitor	H7A	8	b0: RUN (inverter running) ① b1: Forward rotation b2: Reverse rotation b3: SU (up to frequency) ① b4: OL (overload) ① b5: IPF (instantaneous power failure) ① b6: FU (frequency detection) ① b7: ABC1 (alarm) ①	Example 1: H02 (During forward rotation) b7 b0 0 0 0 0 0 0 1 0 Example 2: H80 (Stop at alarm occurrence) b7 b0 0 0 0 0 0 0 1 0
Inverter status monitor (extended)	H79	16	b0: RUN (inverter running) ① b1: Forward rotation b2: Reverse rotation b3: SU (up to frequency) ① b4: OL (overload) ① b5: IPF (instantaneous power failure) ① b6: FU (frequency detection) ① b7: ABC1 (alarm) ① b8: ABC2 (—) ① b9: — b10: — b11: — b12: — b13: — b14: — b15: Alarm occurrence	Example 1: H0002 (During forward rotation) b15 b0 0 0 0 0 0 0 0 0 0 0 0 0 0 0 1 0 Example 2: H8080 ( Stop at alarm occurrence) b15 b0 1 0 0 0 0 0 0 0 1 0 0 0 0 0 0 0

**Tab. 6-146: Monitoring the inverter status**

① The signal within parentheses is the initial setting. The description changes depending on the setting of Pr. 190 to Pr. 196 "Output terminal function selection". (Refer to section 6.14.5.)

## 6.23.6 Modbus-RTU communication (Pr. 331, Pr. 332, Pr. 334, Pr. 343, Pr. 539, Pr. 549)

Using the Modbus-RTU communication protocol, communication operation or parameter setting can be performed from the RS-485 terminals of the inverter.

Pr. No.	Name	Initial Value	Setting Range	Description	Parameters referred to	Refer to Section
331	RS-485 communication station number	0	0	Broadcast communication is selected	—	
			1–247	Specify the inverter station number. Set the inverter station numbers when two or more inverters are connected to one personal computer		
332	RS-485 communication speed	96	3/6/12/24/48/96/192/384	Set the communication speed. The setting value × 100 equals the communication speed. For example, the communication speed is 9600bps when the setting value is '96'.		
334	RS-485 communication parity check selection	2	0	Without parity check Stop bit length: 2bits		
			1	With odd parity check Stop bit length: 1bit		
			2	With even parity check Stop bit length: 1bit		
343	Communication error count	0	—	Display the number of communication errors during Modbus-RTU communication. Reading only		
539	Modbus-RTU communication check time interval	9999	0	Modbus-RTU communication can be made, but the inverter will come to an alarm stop in the NET operation mode.		
			0.1–999.8 s	Set the interval of communication check time. same specifications as Pr. 122)		
			9999	No communication check (signal loss detection)		
549	Protocol selection	0	0	Mitsubishi inverter (computer link) protocol		
			1	Modbus-RTU protocol		

### NOTES

When Modbus RTU communication is performed with "0" (initial value) set in Pr. 331 "RS-485 communication station number", broadcast communication is selected and the inverter does not send a response message to the master. When response from the inverter is necessary, set a value other than "0" in Pr. 331. Some functions are invalid for broadcast communication. (Refer to page 6-473.)

When using the Modbus-RTU protocol, set Pr. 549 "Protocol selection" to "1".

When the communication option is fitted with Pr. 550 "NET mode operation command source selection" set to "9999" (initial value), the command source (e.g. run command) from the RS-485 terminals is invalid. (Refer to section 6.22.3.)

**Communication specifications**

Item	Description	Related Parameters	
Communication protocol	Modbus-RTU protocol	Pr. 549	
Conforming standard	EIA-485 (RS-485)	—	
Number of inverters connected	1 : N (maximum 32 units), setting is 0 to 247 stations	Pr. 331	
Communication speed	Can be selected from 300, 600, 1200, 2400, 4800, 9600, 19200 and 38400bps	Pr. 332	
Control protocol	Asynchronous system	—	
Communication method	Half-duplex system	—	
Communication specifications	Character system	Binary (fixed to 8 bits)	—
	Start bit	1 bit	—
	Stop bit length	Select from the following three types	Pr. 334
	Parity check	<ul style="list-style-type: none"> <li>● No parity, stop bit length: 2 bits</li> <li>● Odd parity, stop bit length: 1 bit</li> <li>● Even parity, stop bit length: 1 bit</li> </ul>	
	Error check	CRC code check	—
Terminator	—	—	
Waiting time setting	—	—	

**Tab. 6-147:** Communication specifications

**Outline**

The Modbus protocol is the communication protocol developed by Modicon for PLC. The Modbus protocol performs serial communication between the master and slave using the dedicated message frame. The dedicated message frame has the functions that can perform data read and write. Using the functions, you can read and write the parameter values from the inverter, write the input command of the inverter, and check the operating status. In this product, the inverter data are classified in the holding register area (register addresses 40001 to 49999). By accessing the assigned holding register address, the master can communicate with the inverter which is a slave..

**NOTE**

There are two different serial transmission modes: ASCII (American Standard Code for Information Interchange) mode and RTU (Remote Terminal Unit) mode. This product supports only the RTU mode in which two hexadecimal coded characters are transmitted in one byte (8 bit) data. Only the communication protocol is defined by the Modbus protocol, and the physical layer is not stipulated.

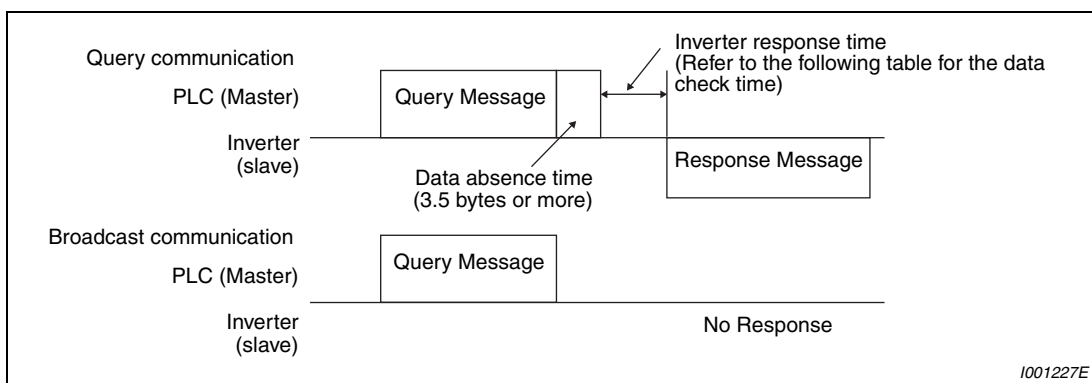

**Fig. 6-232: Message format**

The data check time related to different functions is shown in the table below:

Item	Check Time
Various monitors, operation command, frequency setting (RAM)	< 12ms
Parameter read/write, frequency setting (EEPROM)	< 30ms
Parameter clear/all clear	< 5s
Reset command	—

**Tab. 6-148: Data check time**

- **Query**  
The master sends a message to the slave (= inverter) at the specified address.
- **Normal**  
Response after receiving the query from the master, the slave executes the requested function and returns the corresponding normal response to the master.
- **Error Response**  
If an invalid function code, address or data is received, the slave returns it to the master. When a response description is returned, the error code indicating that the request from the master cannot be executed is added. No response is returned for the hardware-detected error, frame error and CRC check error.
- **Broadcast**  
By specifying address 0, the master can send a message to all slaves. All slaves that received the message from the master execute the requested function. In this communication, the slaves do not return a response to the master.

**NOTE**

The slave executes the function independently of the inverter station number setting (Pr. 331) during broadcast communication.



**Message frame (protocol)**

Communication method

Basically, the master sends a query message (question) and the slave returns a response message (response). When communication is normal, Device Address and Function Code are copied as they are, and when communication is abnormal (function code or data code is illegal), bit 7 (= 80h) of Function Code is turned on and the error code is set to Data Bytes.

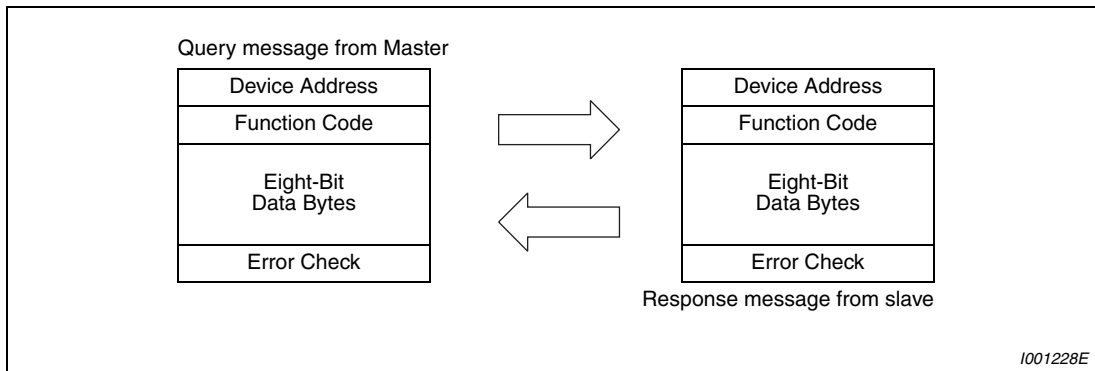

**Fig. 6-233: Data transmission**

The message frame consists of the four message fields as shown above. By adding the no-data time (T1: Start, End) of 3.5 characters to the beginning and end of the message data, the slave recognizes it as one message.

Protocol details

Start	① Address	② Function	③ Data	④ CRC Check		End
T1	8 bit	8 bit	n × 8 bit	L 8 bit	H 8 bit	T1

Message Field	Description																								
① Address field	Is 1 byte long (8 bits), and can be set to any of 0 to 247. Set "0" to send a broadcast message (all-address instruction) or any of 1 to 247 to send a message to each slave. When the slave responds, it returns the address set from the master. The value set to Pr. 331 "RS-485 communication station" is the slave address.																								
② Function field	<p>The function code is 1 byte long (8 bits) and can be set to any of 1 to 255. The master sets the function that it wants to request from the slave, and the slave performs the requested operation. The following table gives the supported function codes. An error response is returned if the set function code is other than those in the following table. When the slave returns a normal response, it returns the function code set by the master. When the slave returns an error response, it returns H80 + function code.</p> <table border="1" style="width: 100%; border-collapse: collapse; margin-top: 10px;"> <thead> <tr> <th style="width: 10%;">Code</th> <th style="width: 40%;">Function Name</th> <th style="width: 30%;">Outline</th> <th style="width: 20%;">Broadcast Communication</th> </tr> </thead> <tbody> <tr> <td>H03</td> <td>Read Holding Register</td> <td>Reads the holding register data.</td> <td>Disallowed</td> </tr> <tr> <td>H06</td> <td>Preset Single Register</td> <td>Writes data to the holding register.</td> <td>Allowed</td> </tr> <tr> <td>H08</td> <td>Diagnostics</td> <td>Makes a function diagnosis. (communication check only)</td> <td>Disallowed</td> </tr> <tr> <td>H10</td> <td>Preset Multiple Registers</td> <td>Writes data to multiple consecutive holding registers.</td> <td>Allowed</td> </tr> <tr> <td>H46</td> <td>Read Holding Register Access Log</td> <td>Reads the number of registers that succeeded in communication last time.</td> <td>Disallowed</td> </tr> </tbody> </table>	Code	Function Name	Outline	Broadcast Communication	H03	Read Holding Register	Reads the holding register data.	Disallowed	H06	Preset Single Register	Writes data to the holding register.	Allowed	H08	Diagnostics	Makes a function diagnosis. (communication check only)	Disallowed	H10	Preset Multiple Registers	Writes data to multiple consecutive holding registers.	Allowed	H46	Read Holding Register Access Log	Reads the number of registers that succeeded in communication last time.	Disallowed
Code	Function Name	Outline	Broadcast Communication																						
H03	Read Holding Register	Reads the holding register data.	Disallowed																						
H06	Preset Single Register	Writes data to the holding register.	Allowed																						
H08	Diagnostics	Makes a function diagnosis. (communication check only)	Disallowed																						
H10	Preset Multiple Registers	Writes data to multiple consecutive holding registers.	Allowed																						
H46	Read Holding Register Access Log	Reads the number of registers that succeeded in communication last time.	Disallowed																						
③ Data field	The format changes depending on the function code (refer to page 6-474). Data includes the byte count, number of bytes, description of access to the holding register, etc.																								
④ CRC check field	The received message frame is checked for error. CRC check is performed, and 2 byte long data is added to the end of the message. When CRC is added to the message, the low-order byte is added first and is followed by the high-order byte. The CRC value is calculated by the sending side that adds CRC to the message. The receiving side recalculates CRC during message receiving, and compares the result of that calculation and the actual value received in the CRC check field. If these two values do not match, the result is defined as error.																								

**Tab. 6-149: Protocol details**

**Message format types**

The message formats corresponding to the function codes in Tab. 6-149 will be explained.

- Read holding register data (H03 or 03)  
Can read the description of system environment variables, real-time monitor, alarm history, and inverter parameters assigned to the holding register area. (Refer to the register list on page 6-482.)

Query Message

① Slave Address	② Function	③ Starting Address		④ No. of Points		CRC Check	
(8 bit)	H03 (8 bit)	H (8 bit)	L (8 bit)	H (8 bit)	L (8 bit)	L (8 bit)	H (8 bit)

Response message

① Slave Address	② Function	⑤ Byte Count	⑥ Data			CRC Check	
(8 bit)	H03 (8 bit)	(8 bit)	H (8 bit)	L (8 bit)	... n × 16 bit	L (8 bit)	H (8 bit)

Message		Description
①	Slave Address	Set the address to which the message will be sent. Broadcast communication cannot be made (0 is invalid)
②	Function	Set H03.
③	Starting Address	Set the address at which holding register data read will be started. Starting address = starting register address (decimal) – 40001 For example, setting of the starting address 0001 reads the data of the holding register 40002.
④	No. of Points	Set the number of holding registers from which data will be read. The number of registers from which data can be read is a maximum of 125.

**Tab. 6-150:** Description of the query message

Message		Description
⑤	Byte Count	The setting range is H02 to H14 (2 to 20). Twice greater than the No. of Points specified at ④ is set.
⑥	Data	The number of data specified at ④ is set. Data are read in order of Hi byte and Lo byte, and set in order of starting address data, starting address + 1 data, starting address + 2 data, ...

**Tab. 6-151:** Description of normal response

**Example** ▾

To read the register values of 41004 (Pr. 4) to 41006 (Pr. 6) from the slave address 17 (H11).

## Query message

Slave Address	Function	Starting Address		No. of Points		CRC Check	
H11 (8 bit)	H03 (8 bit)	H03 (8 bit)	HEB (8 bit)	H00 (8 bit)	H03 (8 bit)	H77 (8 bit)	H2B (8 bit)

## Normal response (Response message)

Slave Address	Function	Byte Count	Data						CRC Check	
H11 (8 Bit)	H03 (8 Bit)	H06 (8 Bit)	H17 (8 Bit)	H70 (8 Bit)	H0B (8 Bit)	HB8 (8 Bit)	H03 (8 Bit)	HE8 (8 Bit)	H2C (8 Bit)	HE6 (8 Bit)

Read value:

Register 41004 (Pr. 4): H1770 (60.00Hz)

Register 41005 (Pr. 5): H0BB8 (30.00Hz)

Register 41006 (Pr. 6): H03E8 (10.00Hz)

△

- Write multiple holding register data (H06 or 06)  
You can write the description of system environment variables and inverter parameters assigned to the holding register area. (Refer to the register list on page 6-482.)

Query message

① Slave Address	② Function	③ Register Address		④ Preset Data		CRC Check	
(8 bit)	H06 (8 bit)	H (8 bit)	L (8 bit)	H (8 bit)	L (8 bit)	L (8 bit)	H (8 bit)

Normal response (Response message)

① Slave Address	② Function	③ Register Address		④ Preset Data		CRC Check	
(8 bit)	H06 (8 bit)	H (8 bit)	L (8 bit)	H (8 bit)	L (8 bit)	L (8 bit)	H (8 bit)

Message		Description
①	Slave Address	Set the address to which the message will be sent. Setting of address 0 enables broadcast communication.
②	Function	Set H06.
③	Register Address	Set the address of the holding register to which data will be written. Register address = holding register address (decimal) – 40001 For example, setting of register address 0001 writes data to the holding register address 40002.
④	Preset Data	Set the data that will be written to the holding register. The written data is fixed to 2 bytes.

Tab. 6-152: Description of the query message

The normal response data ① to ④ (including CRC check) of the normal response are the same as those of the query message. No response is made for broadcast communication.

**Example** ▽

To write 60Hz (H1770) to 40014 (running frequency RAM) at slave address 5 (H05).

Query message

Slave Address	Function	Register Address		Preset Data		CRC Check	
H05 (8 bit)	H06 (8 bit)	H00 (8 bit)	H0D (8 bit)	H17 (8 bit)	H70 (8 bit)	H17 (8 bit)	H99 (8 bit)

Normal Response (Response message):  
Same data as the query message.



**NOTE**

For broadcast communication, no response is returned in reply to a query. Therefore, the next query must be made when the inverter processing time has elapsed after the previous query.

- Function diagnosis (H08 or 08)

A communication check can be made since the query message sent is returned unchanged as a response message (function of subfunction code H00). Subfunction code H00 (Return Query Data).

## Query message

① Slave Address	② Function	③ Subfunction		④ Data		CRC Check	
(8 bit)	H08 (8 bit)	H00 (8 bit)	H00 (8 bit)	H (8 bit)	L (8 bit)	L (8 bit)	H (8 bit)

## Normal response (Response message)

① Slave Address	② Function	③ Subfunction		④ Data		CRC Check	
(8 bit)	H08 (8 bit)	H00 (8 bit)	H00 (8 bit)	H (8 bit)	L (8 bit)	L (8 bit)	H (8 bit)

Message		Description
①	Slave Address	Set the address to which the message will be sent. Broadcast communication cannot be made (0 is invalid)
②	Function	Set H08.
③	Subfunction	Set H0000.
④	Data	Any data can be set if it is 2 bytes long. The setting range is H0000 to HFFFF.

**Tab. 6-153:** Description of the query message

The normal response data ① to ④ (including CRC check) of the normal response are the same as those of the query message.

**NOTE**

For broadcast communication, no response is returned in reply to a query. Therefore, the next query must be made when the inverter processing time has elapsed after the previous query.

- Write multiple holding register data (H10 or 16)  
You can write data to multiple holding registers.

Query message

① Slave Address (8 bit)	② Function H10 (8 bit)	③ Starting Address		④ No. of Registers		⑤ Byte Count (8 bit)	⑥ Data				CRC Check	
		H (8 bit)	L (8 bit)	H (8 bit)	L (8 bit)		H (8 bit)	L (8 bit)	...	n × 2 × 8 bit	L (8 bit)	H (8 bit)

Normal response (Response message)

① Slave Address (8 bit)	② Function H10 (8 bit)	③ Starting Address		④ No. of Registers		CRC Check	
		H (8 bit)	L (8 bit)	H (8 bit)	L (8 bit)	L (8 bit)	H (8 bit)

Message		Description
①	Slave Address	Set the address to which the message will be sent. Setting of address 0 enables broadcast communication.
②	Function	Set H10.
③	Starting Address	Set the address where holding register data write will be started. Starting address = starting register address (decimal) – 40001 For example, setting of the starting address 0001 reads the data of the holding register 40002.
④	No. of Points	Set the number of holding registers where data will be written. The number of registers where data can be written is a maximum of 125.
⑤	Byte Count	The setting range is H02 to HFA (0 to 250). Set twice greater than the value specified at ④.
⑥	Data	Set the data specified by the number specified at ④. The written data are set in order of Hi byte and Lo byte, and arranged in order of the starting address data, starting address + 1 data, starting address + 2 data ...

Tab. 6-154: Description of the query message

The normal response data ① to ④ (including CRC check) of the normal response are the same as those of the query message.

**Example** ▽

To write 0.5s (H05) to 41007 (Pr. 7) at the slave address 25 (H19) and 1s (H0A) to 41008 (Pr. 8).

Query message

Slave Address	Function	Starting Address		No. of Registers		Byte Count	Data				CRC Check	
H19 (8 bit)	H10 (8 bit)	H03 (8 bit)	HEE (8 bit)	H00 (8 bit)	H02 (8 bit)	H04 (8 bit)	H00 (8 bit)	H05 (8 bit)	H00 (8 bit)	H0A (8 bit)	H86 (8 bit)	H3D (8 bit)

Normal response (Response message)

Slave Address	Function	Starting Address		No. of Registers		Byte Count	CRC Check	
H19 (8 bit)	H10 (8 bit)	H03 (8 bit)	HEE (8 bit)	H00 (8 bit)	H02 (8 bit)	H04 (8 bit)	H22 (8 bit)	H61 (8 bit)



- Read holding register access log (H46 or 70)

A response can be made to a query made by the function code H03, H06 or H0F.

The starting address of the holding registers that succeeded in access during previous communication and the number of successful registers are returned.

In response to the query for other than the above function code, "0" is returned for the address and number of registers.

## Query message

① Slave Address	② Function	CRC Check	
(8 bit)	H46 (8 bit)	L (8 bit)	H (8 bit)

## Normal response (Response message)

① Slave Address	② Function	③ Starting Address		④ No. of Points		CRC Check	
(8 bit)	H46 (8 bit)	H (8 bit)	L (8 bit)	H (8 bit)	L (8 bit)	L (8 bit)	H (8 bit)

Message		Description
①	Slave Address	Set the address to which the message will be sent. Broadcast communication cannot be made (0 is invalid)
②	Function	Set H46.

**Tab. 6-155:** Description of the query message

Message		Description
③	Starting Address	The starting address of the holding registers that succeeded in access is returned. Starting address = starting register address (decimal) – 40001 For example, when the starting address 0001 is returned, the address of the holding register that succeeded in access is 40002.
④	No. of Points	The number of holding registers that succeeded in access is returned.

**Tab. 6-156:** Description of normal response

**Example** ▾

To read the successful register starting address and successful count from the slave address 25 (H19).

## Query message

Slave Address	Function	CRC Check	
H19 (8 bit)	H46 (8 bit)	H8B (8 bit)	HD2 (8 bit)

## Normal response (Response message)

Slave Address	Function	Starting Address		No. of Points		CRC Check	
H19 (8 bit)	H10 (8 bit)	H03 (8 bit)	HEE (8 bit)	H00 (8 bits)	H02 (8 bit)	H22 (8 bit)	H61 (8 bit)

Success of two registers at starting address 41007 (Pr. 7) is returned.

△

- Error response

An error response is returned if the query message received from the master has an illegal function, address or data. No response is returned for a parity, CRC, overrun, framing or busy error.

**NOTE**

No response message is sent in the case of broadcast communication also.

## Error response (Response message)

① Slave Address	② Function	③ Exception Code	CRC Check	
(8 bit)	H80 + Function (8 bit)	(8 bit)	L (8 bit)	H (8 bit)

Message	Description
① Slave address	Set the address received from the master.
② Function	The master-requested function code + H80 is set.
③ Exception code	The code in the following table is set.

**Tab. 6-157:** Description of response data

Code	Error Item	Description
01	ILLEGAL FUNCTION (Function code illegal)	The set function code in the query message from the master cannot be handled by the slave.
02	ILLEGAL DATA ADDRESS ① (Address illegal)	The set register address in the query message from the master cannot be handled by the inverter. (No parameter, parameter read disabled, parameter write disabled)
03	ILLEGAL DATA VALUE (Data illegal)	The set data in the query message from the master cannot be handled by the inverter. (Out of parameter write range, mode specified, other error)

**Tab. 6-158:** Error code list

① An error will not occur in the following cases:

- Function code H03 (Read Holding Register Data )  
When the No. of Points is 1 or more and there is one or more holding registers from which data can be read.
- Function code H10 (Write Multiple Holding Register Data)  
When the No. of Points is 1 or more and there is 1 or more holding registers to which data can be written.

Namely, when the function code H03 or H10 is used to access multiple holding registers, an error will not occur if a non-existing holding register or read disabled or write disabled holding register is accessed.

**NOTES**

An error will occur if all accessed holding registers do not exist.

Data read from a non-existing holding register is 0, and data written there is invalid.



To detect the mistakes of message data from the master, they are checked for the following errors. If an error is detected, an alarm stop will not occur.

Error Item	Error Definition	Inverter Side Operation
Parity error	The data received by the inverter differs from the specified parity (Pr. 334 setting).	Pr. 343 is increased by 1 at error occurrence. ① The terminal LF is output at error occurrence. ②
Framing error	The data received by the inverter differs from the specified stop bit length (Pr. 333).	
Overrun error	The following data was sent from the master before the inverter completes data receiving.	
Message frame error	The message frame data length is checked, and the received data length of less than 4 bytes is regarded as an error.	
CRC check error	A mismatch found by CRC check between the message frame data and calculation result is regarded as an error.	

Tab. 6-159: Error check item

① You can check the cumulative number of communication errors.

Parameters	Setting Range	Minimum Setting Range	Initial Value
343	(Read only)	1	0

Tab. 6-160: Number of communication errors

**NOTE**

The number of communication errors is temporarily stored into the RAM. As it is not stored into the EEPROM, performing a power supply reset or inverter reset clears the value to 0.

② During a communication error, the minor failure output (LF signal) is output by open collector output. Assign the used terminal using any of Pr. 190 to Pr. 196 "Output terminal function selection".

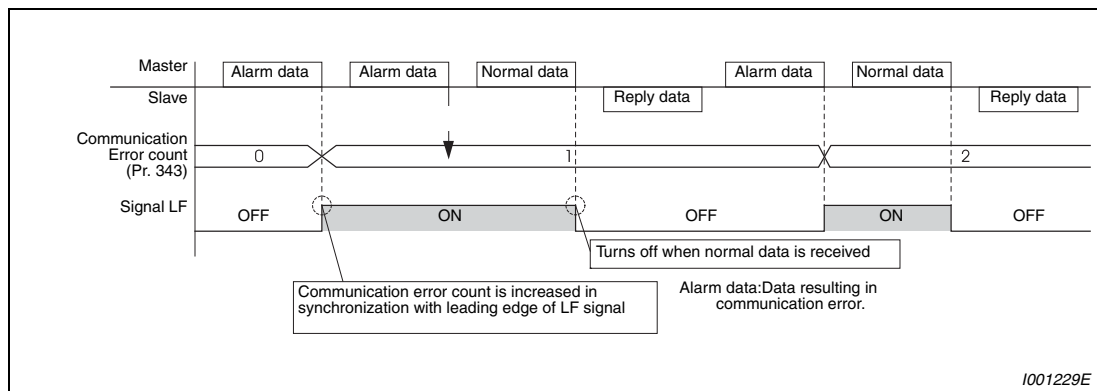

Fig. 6-234: Output of the LF signal

**NOTE**

The LF signal can be assigned to the output terminal using any of Pr. 190 to Pr. 196. When terminal assignment is changed, the other functions may be affected. Please make setting after confirming the function of each terminal.

**Modbus registers**

## ● System environment variable

Register	Definition	Read/write	Remarks
40002	Inverter reset	Write	Any value can be written
40003	Parameter clear	Write	Set H965A as a written value.
40004	All parameter clear	Write	Set H99AA as a written value.
40006	Parameter clear <sup>①</sup>	Write	Set H5A96 as a written value.
40007	All parameter clear <sup>①</sup>	Write	Set HAA99 as a written value.
40009	Inverter status/control input instruction <sup>②</sup>	Read/write	Refer to Tab. 6-162
40010	Operation mode/inverter setting <sup>③</sup>	Read/write	Refer to Tab. 6-163
40014	Running frequency (RAM value)	Read/write	According to the Pr. 37 and Pr. 144 settings, the frequency and selectable speed are in 1r/min increments.
40015	Running frequency (EEPROM value)	Write	

**Tab. 6-161:** System environment variable

- ① The communication parameter values are not cleared.
- ② For write, set the data as a control input instruction. For read, data is read as an inverter operating status.
- ③ For write, set data as the operation mode setting. For read, data is read as the operation mode status.

Bit	Definition	
	Control input instruction	Inverter status
0	Stop command	RUN (inverter running) <sup>②</sup>
1	Forward rotation command	Forward rotation
2	Reverse rotation command	Reverse rotation
3	RH (high speed operation command) <sup>①</sup>	SU (up to frequency) <sup>②</sup>
4	RM (middle speed operation command) <sup>①</sup>	OL (overload) <sup>②</sup>
5	RL (low speed operation command) <sup>①</sup>	IPF (instantaneous power failure) <sup>②</sup>
6	JOG (Jog operation) <sup>①</sup>	FU (frequency detection) <sup>②</sup>
7	RT (second function selection) <sup>①</sup>	ABC1 (alarm) <sup>②</sup>
8	AU (current input selection) <sup>①</sup>	ABC2 (-) <sup>②</sup>
9	CS (selection of automatic restart after instantaneous power failure) <sup>①</sup>	0
10	MRS (output stop) <sup>①</sup>	0
11	STOP (start self-holding) <sup>①</sup>	0
12	RES (reset) <sup>①</sup>	0
13	0	0
14	0	0
15	0	Alarm

**Tab. 6-162:** Inverter status/control input instruction

- <sup>①</sup> The signal within parentheses is the initial setting. The description changes depending on the setting of Pr. 180 to Pr. 189 "Input terminal function selection". (Refer to section 6.14.1.) Each assigned signal is valid or invalid depending on NET. (Refer to section 6.22.3.)
- <sup>②</sup> The signal within parentheses is the initial setting. The description changes depending on the setting of Pr. 190 to Pr. 196 "Output terminal function selection". (Refer to section 6.14.5.)

Operation Mode	Read Value	Written Value
EXT	H0000	H0010
PU	H0001	—
EXT JOG	H0002	—
NET	H0004	H0014
PU + EXT	H0005	—

**Tab. 6-163:** Operation mode/inverter setting

The restrictions depending on the operation mode changes according to the computer link specifications.

- Real-time monitor  
Refer to section 6.15.2 for details of the monitor description.

Register	Description	Unit	Register	Description	Unit
40201	Output frequency	0.01Hz	40220	Cumulative energizing time	1h
40202	Output current	0.01A/0.1A <sup>⑥</sup>	40222	Orientation status	—
40203	Output voltage	0.1V	40223	Actual operation time	1h
40205	Frequency setting	0.01Hz	40224	Motor load factor	0.1%
40206	Running speed	1U/min	40225	Cumulative power	1kWh
40207			40226	Torque command	0.1%
40208	Converter output voltage	0.1V	40227	Torque current command	0.1%
40209	Regenerative brake duty	0.1%	40228	Motor output	0.01kW/0.1kW <sup>①</sup>
40210	Electronic thermal relay function load factor	0.1%	40229	Feedback pulse	—
40211	Output current peak value	0.01A/0.1A <sup>⑥</sup>	40250	Power saving effect	Variable
40212	Converter output voltage peak value	0.1V	40251	Cumulative saving power	Variable
40213	Input power	0.01kW/0.1kW <sup>⑥</sup>	40252	PID set point	0.1%
40214	Output power	0.01kW/0.1kW <sup>⑥</sup>	40253	PID measurement value	0.1%
40215	Input terminal status <sup>①</sup>	—	40254	PID deviation value	0.1%
40216	Output terminal status <sup>②</sup>	—	40258	Option input terminal status 1 <sup>③</sup>	—
40217	Load meter	0.1%	40259	Option input terminal status 2 <sup>④</sup>	
40218	Motor excitation current	0.01A/0.1A <sup>⑥</sup>	40260	Option output terminal status <sup>⑤</sup>	
40219	Position pulse	—	—	—	—

**Tab. 6-164: Real-time monitor**

- ① Input terminal monitor details (remote input)

b15															b0		
—	—	—	—	CS	RES	STOP	MRS	JOG	RH	RM	RL	RT	AU	STR	STF		

- ② Output terminal monitor details

b15															b0		
—	—	—	—	—	—	—	—	—	—	ABC2	ABC1	FU	OL	IPF	SU	RUN	

- ③ Details of option input terminal monitor 1 (input terminal status of FR-A7AX)-all terminals are off when an option is not fitted

b15															b0		
X15	X14	X13	X12	X11	X10	X9	X8	X7	X6	X5	X4	X3	X2	X1	X0		

- ④ Details of option input terminal monitor 2 (input terminal status of FR-A7AX)-all terminals are off when an option is not fitted

b15															b0		
—	—	—	—	—	—	—	—	—	—	—	—	—	—	—	—	DY	

- ⑤ Details of option output terminal monitor (output terminal status of FR-A7AY/A7AR)-all terminals are off when an option is not fitted

b15															b0		
—	—	—	—	—	—	—	RA3	RA2	RA1	Y6	Y5	Y4	Y3	Y2	Y1	Y0	

- ⑥ The setting depends on capacities. (01800 or less / 02160 or more)

## ● Parameter

Parameter	Register	Parameter Name	Read/write	Remarks
0-999	41000-41999	Refer to the parameter list (Tab. 6-1) for the parameter names.	Read/write	The parameter number + 41000 is the register number.
C2 (902)	41902	Terminal 2 frequency setting bias (frequency)	Read/write	
C3 (902)	42092	Terminal 2 frequency setting bias (analog value)	Read/write	The analog value (%) set to C3 (902) is read.
	43902	Terminal 2 frequency setting bias (terminal analog value)	Read	The analog value (%) of the voltage (current) applied to the terminal 2 is read.
125 (903)	41903	Terminal 2 frequency setting gain (frequency)	Read/write	
C4 (903)	42093	Terminal 2 frequency setting gain (analog value)	Read/write	The analog value (%) set to C4 (903) is read.
	43903	Terminal 2 frequency setting gain (terminal analog value)	Read	The analog value (%) of the voltage (current) applied to the terminal 2 is read.
C5 (904)	41904	Terminal 4 frequency setting bias (frequency)	Read/write	
C6 (904)	42094	Terminal 4 frequency setting bias (analog value)	Read/write	The analog value (%) set to C6 (904) is read.
	43904	Terminal 4 frequency setting bias (terminal analog value)	Read	The analog value (%) of the current (voltage) applied to the terminal 4 is read.
126 (905)	41905	Terminal 4 frequency setting gain (frequency)	Read/write	
C7 (905)	42095	Terminal 4 frequency setting gain (analog value)	Read/write	The analog value (%) set to C7 (905) is read.
	43905	Terminal 4 frequency setting gain (terminal analog value)	Read	The analog value (%) of the current (voltage) applied to the terminal 4 is read.
C8 (930)	41930	Current output bias signal	Read/write	
C9 (930)	42120	Current output bias current	Read/write	
C10 (931)	41931	Current output gain signal	Read/write	
C11 (931)	42121	Current output gain current	Read/write	
C12 (917)	41917	Terminal 1 bias frequency (speed)	Read/write	
C13 (917)	42107	Terminal 1 bias (speed)	Read/write	Analog value (%) set in C13 (917) is read.
	43917	Terminal 1 bias (speed) (terminal analog value)	Read	Analog value (%) of the voltage applied to terminal 1 is read.
C14 (918)	41918	Terminal 1 gain frequency (speed)	Read/write	
C15 (918)	42108	Terminal 1 gain (speed)	Read/write	Analog value (%) set in C15 (918) is read.
	43918	Terminal 1 gain (speed) (terminal analog value)	Read	Analog value (%) of the voltage applied to terminal 1 is read.
C16 (919)	41919	Terminal 1 bias command (torque/magnetic flux)	Read/write	

Tab. 6-165: Parameter

Parameter	Register	Parameter Name	Read/write	Remarks
C17 (919)	42109	Terminal 1 bias (torque/magnetic flux)	Read/write	Analog value (%) set in C17 (919) is read.
	43919	Terminal 1 bias (torque/magnetic flux) (terminal analog value)	Read	Analog value (%) of the voltage applied to terminal 1 is read.
C18 (920)	41920	Terminal 1 gain command (torque/magnetic flux)	Read/write	
C19 (920)	42110	Terminal 1 gain (torque/magnetic flux)	Read/write	Analog value (%) set in C19 (920) is read.
	43920	Terminal 1 gain (torque/magnetic flux) (terminal analog value)	Read	Analog value (%) of the voltage applied to terminal 1 is read.
C38 (932)	41932	Terminal 4 bias command (torque/magnetic flux)	Read/write	
C39 (932)	42122	Terminal 4 bias (torque/magnetic flux)	Read/write	Analog value (%) set in C39 (932) is read.
	43932	Terminal 4 bias (torque/magnetic flux) (terminal analog value)	Read	Analog value (%) of the cur- rent (voltage) applied to termi- nal 4 is read.
C40 (933)	41933	Terminal 4 gain command (torque/magnetic flux)	Read/write	
C41 (933)	42123	Terminal 4 gain (torque/magnetic flux)	Read/write	Analog value (%) set in C41 (933) is read.
	43933	Terminal 4 gain (torque/magnetic flux) (terminal analog value)	Read	Analog value (%) of the cur- rent (voltage) applied to termi- nal 4 is read.

**Tab. 6-165: Parameter (2)**

● Alarm history

Register	Definition	Read/write	Remarks
40501	Alarm history 1	Read/write	Being 2 bytes in length, the data is stored as "H00□□". The error code can be referred to in the low-order 1 byte. Performing write using the register 40501 batch-clears the alarm history. Set any value as data.
40502	Alarm history 2	Read	
40503	Alarm history 3	Read	
40504	Alarm history 4	Read	
40505	Alarm history 5	Read	
40506	Alarm history 6	Read	
40507	Alarm history 7	Read	
40508	Alarm history 8	Read	

**Tab. 6-166:** Alarm history

Data	Description	Data	Description	Data	Description
H00	No alarm	H91	E.PTC	HD3	E.OD
H10	E.OC1	HA0	E.OPT	HD5	E.MB1
H11	E.OC2	HA3	E.OP3	HD6	E.MB2
H12	E.OC3	HB0	E.PE	HD7	E.MB3
H20	E.OV1	HB1	E.PUE	HD8	E.MB4
H21	E.OV2	HB2	E.RET	HD9	E.MB5
H22	E.OV3	HB3	E.PE2	HDA	E.MB6
H30	E.THT	HC0	E.CPU	HDB	E.MB7
H31	E.THM	HC1	E.CTE	HDC	E.EP
H40	E.FIN	HC2	E.P24	HF1	E.1
H50	E.IPF	HC4	E.CDO	HF2	E.2
H51	E.UVT	HC5	E.IOH	HF3	E.3
H52	E.ILF	HC6	E.SER	HF6	E.6
H60	E.OLT	HC7	E.AIE	HF7	E.7
H70	E.BE	HC8	E.USB	HFB	E.11
H80	E.GF	HD0	E.OS	HFD	E.13
H81	E.LF	HD1	E.OSD	—	—
H90	E.OHT	HD2	E.ECT	—	—

**Tab. 6-167:** Alarm data

**NOTE**

Refer to section 7.1 for details of alarm description.

**Signal loss detection (Pr. 539)**

If a signal loss (communication stop) is detected between the inverter and master as a result of a signal loss detection, a communication error (E.SER) occurs and the inverter output is shut off.

When the setting is "9999", communication check (signal loss detection) is not made.

When the setting value is "0", monitor, parameter read, etc. can be performed. However, a communication error (E.SER) occurs as soon as the inverter is switched to the network operation mode.

A signal loss detection is made when the setting is any of "0.1s to 999.8s". To make a signal loss detection, it is necessary to send data from the master within the communication check time interval. (The inverter makes communication check (clearing of communication check counter) regardless of the station number setting of the data sent from the master.)

Communication check is started from the first communication after switching to the network operation mode (use Pr. 551 "PU mode operation command source selection" to change).

Communication check time of query communication includes data absence time (3.5 byte). Since this data absence time differs according to the communication speed, make setting considering this absence time.

**Example ▾**

RS-485 terminal communication, Pr. 539 = "0.1 to 999.8s"

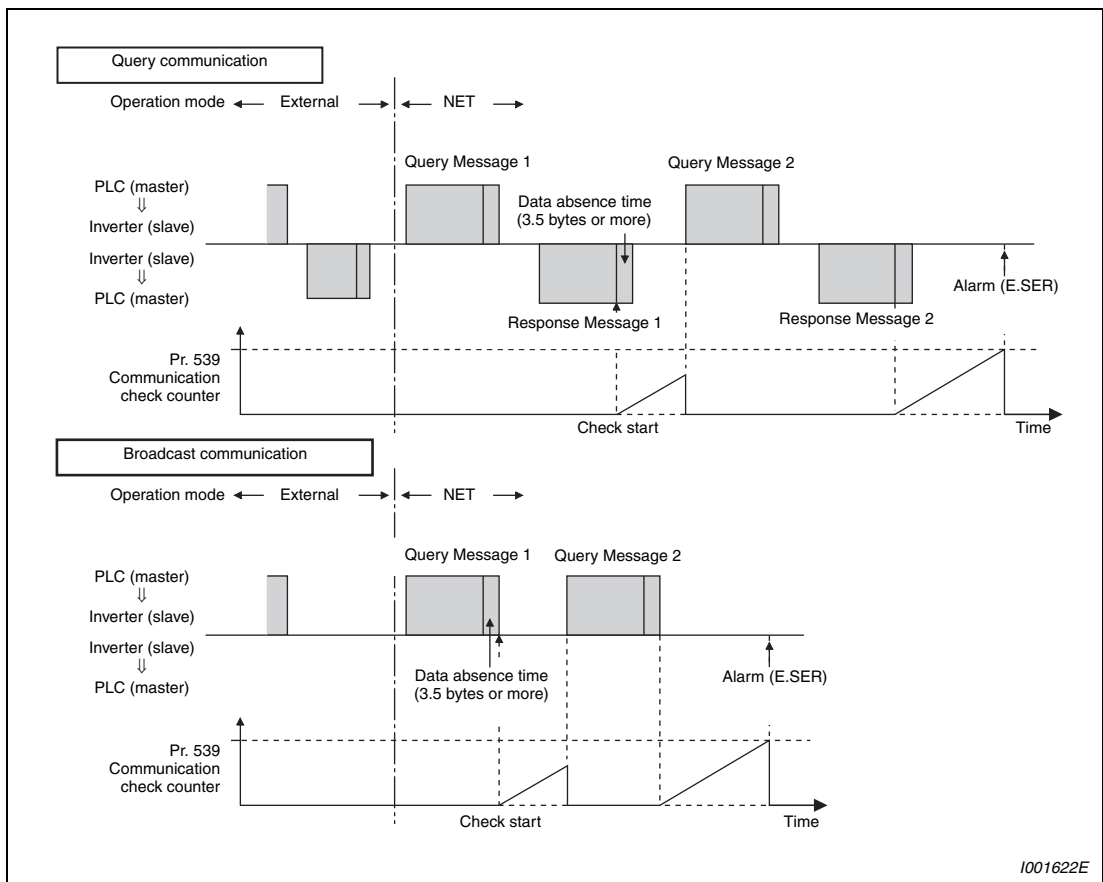

**Fig. 6-235: Signal loss detection**



## 6.23.7 Operation by PLC function (Pr. 414 to Pr. 417, Pr. 498, Pr. 506 to 515)

I/O data read, write, etc. can be performed by accessing the inverter in the predetermined method using special relays, special registers, etc.

Operation, parameter read/write, etc. can be performed in accordance with the created sequence programs (built in the inverter) using input data from the control input terminals.

With the output signals, output data can be output to outside the inverter from the control output terminals as not only the inverter's status signals but also pilot lamp on/off, interlock and other control signals set freely by the user.

Pr. No.	Name	Initial Value	Setting Range	Description	Parameters referred to	Refer to Section
<b>414</b>	PLC function operation selection	0	0	PLC function is invalid	—	
			1	PLC function is valid (Inverter reset is necessary to make this setting valid.)		
<b>415</b>	Inverter operation lock mode setting	0	0	The inverter start signal is made valid regardless of the sequence program execution key.		
			1	The inverter start signal is made valid only when the sequence program execution key is set to RUN. When the sequence program execution key is in the STOP position, the inverter does not start if the inverter start signal STF or STR is turned on. (If the key is switched from RUN to STOP during inverter operation, the inverter is decelerated to a stop.)		
<b>416</b>	Pre-scale function selection	0	0 to 5	Pre-scale function selection (increments scaling factor) 0: No function 1: × 1 2: × 0.1 3: × 0.01 4: × 0.001 5: × 0.0001		
<b>417</b>	Pre-scale setting value	1	0 to 32767	Set the pre-scale value to calculate the number of sampling pulse when inputting the pulse train.		
<b>498</b>	PLC function flash memory clear	0	0 to 9999	9696: Flash memory clear Other than 9696: Flash memory is not cleared		
<b>506</b>	Parameter 1 for user	0	0 to 65535	Inverter parameters Pr. 506 to Pr. 515 can be used as user parameters. Since this parameter area and the devices used with the PLC function, D110 to D119, are accessible to each other, the values set in Pr. 506 to Pr. 515 can be used in a sequence program. The result of operation performed in the sequence program can also be monitored using Pr. 506 to Pr. 515.		
<b>507</b>	Parameter 2 for user					
<b>508</b>	Parameter 3 for user					
<b>509</b>	Parameter 4 for user					
<b>510</b>	Parameter 5 for user					
<b>511</b>	Parameter 6 for user					
<b>512</b>	Parameter 7 for user					
<b>513</b>	Parameter 8 for user					
<b>514</b>	Parameter 9 for user					
<b>515</b>	Parameter 10 for user					

Refer to the FR-A700 PLC function programming manual for details of the PLC function.

### 6.23.8 USB communication (Pr. 547, Pr. 548)

Inverter setup can be easily performed using the FR Configurator by connecting the inverter and personal computer with a USB cable.

Pr. No.	Name	Initial Value	Setting Range	Description	Parameters referred to	Refer to Section
<b>547</b>	USB communication station number	0	0 to 31	Inverter station number specification	551 PU mode operation command source selection	6.22.3
<b>548</b>	USB communication check time interval	9999	0	USB communication is enabled. However, the inverter will come to an alarm stop (E. USB) if operation is changed to PU operation mode.		
			0.1 to 999.8s	Sets the interval of communication check time. If a no-communication state persists for longer than the permissible time, the inverter will come to trip (E.USB).		
			9999	No communication check		

Specification	Description
Interface	Conforms to USB1.1
Transmission speed	12Mbps
Wiring Length	5m
Connector	USB mini B connector (receptacle mini B type)
Power supply	Self-power supply

**Tab. 6-168:** USB communication specifications

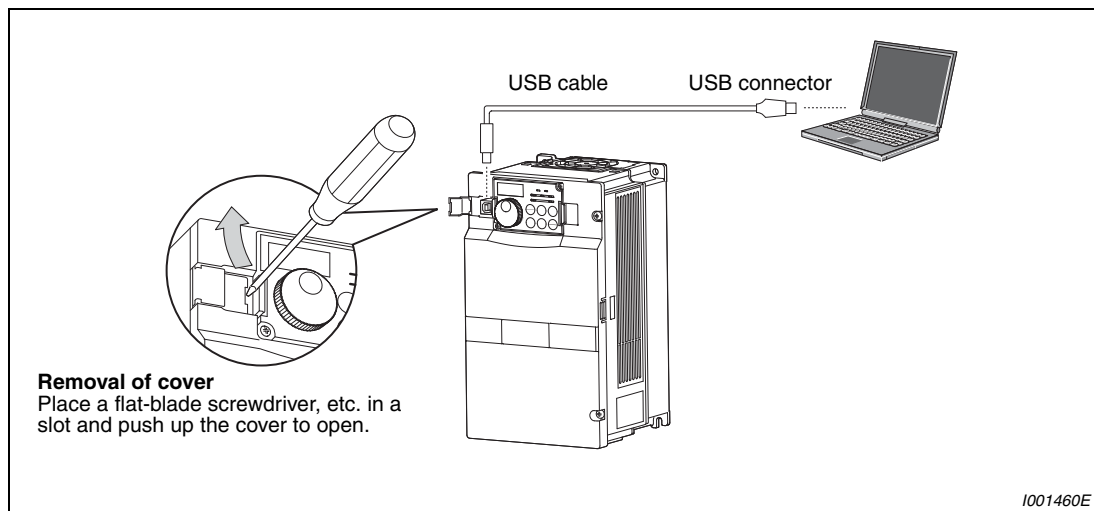

**Fig. 6-236:** Connection to the USB interface

When using USB communication, set "3" in Pr. 551 "PU mode operation command source selection."

You can perform parameter setting and monitoring with the FR Configurator. Refer to the instruction manual of the FR-Configurator for details.

## 6.24 Special operation

Purpose	Parameters that must be set		Refer to Section
Perform process control such as pump and air volume.	PID control	Pr. 127–Pr. 134, Pr. 575–Pr. 577	6.24.1
Switch between the inverter operation and commercial power-supply operation to operate.	Commercial power supply inverter switchover function	Pr. 135–Pr. 139, Pr. 159	6.24.2
Increase speed when the load is light.	Load torque high speed frequency control	Pr. 4, Pr. 5, Pr. 270–Pr. 274	6.24.3
Frequency control appropriate for the load torque	Droop control	Pr. 286–Pr. 288	6.24.4
Frequency setting by pulse train input	Pulse train input	Pr. 291, Pr. 384–Pr. 386	6.24.5
Make the motor speed constant by encoder	Encoder feedback control	Pr. 144, Pr. 285, Pr. 359, Pr. 367–Pr. 369	6.24.6
Traverse function	Traverse function	Pr. 592–Pr. 597	6.24.7
Avoid overvoltage alarm due to regeneration by automatic adjustment of output frequency	Regeneration avoidance function	Pr. 882–Pr. 886	6.24.8

### 6.24.1 PID control (Pr. 127 to Pr. 134, Pr. 575 to Pr. 577)

The inverter can be used to exercise process control, e.g. flow rate, air volume or pressure.

The terminal 2 input signal or parameter setting is used as a set point and the terminal 4 input signal used as a feedback value to constitute a feedback system for PID control.

Pr. No.	Name	Initial Value	Setting Range	Description	Parameters referred to	Refer to Section	
<b>127</b>	PID control automatic switchover frequency	9999	0–400Hz	Set the frequency at which the control is automatically changed to PID control.	59 Remote function selection	6.10.4	
			9999	Without PID automatic switchover function			73 Analog input selection
<b>128</b>	PID action selection	10	10	PID reverse action	Output signal of an external PID controller: terminal 1	79 Operation mode selection	6.22.1
			11	PID forward action			
			20	PID reverse action	Measured value (terminal 4)	190–196 Output terminal function selection	6.14.5
			21	PID forward action	Set point (terminal 2 or Pr. 133)		
			50	PID reverse action	Deviation value signal input (LONWORKS , CC-Link communication)		
			51	PID forward action			
			60	PID reverse action	Measured value, set point input (LONWORKS , CC-Link communication)		
			61	PID forward action			
			70 ②	PID reverse action	Deviation value signal input (PLC function)		
			71 ②	PID forward action			
			80 ②	PID reverse action	Measured value, set point input (PLC function)		
			81 ②	PID forward action			
			90 ②	PID reverse action	Deviation value signal input (PLC function) (Not reflected to the inverter frequency)		
			91 ②	PID forward action			
100 ②	PID reverse action	Measured value, set point input (PLC function) (Not reflected to the inverter frequency)					
101 ②	PID forward action						
<b>129</b>	PID proportional band ①	100%	0.1–1000%	If the proportional band is narrow (parameter setting is small), the manipulated variable varies greatly with a slight change of the measured value. Hence, as the proportional band narrows, the response sensitivity (gain) improves but the stability deteriorates, e.g. hunting occurs. Gain $K_p = 1/\text{proportional band}$			
			9999	No proportional control			
<b>130</b>	PID integral time ①	1s	0.1–3600s	For deviation step input, time (Ti) required for only the integral (I) action to provide the same manipulated variable as that for the proportional (P) action. As the integral time decreases, the set point is reached earlier but hunting occurs more easily.			
			9999	No integral control.			
<b>131</b>	PID upper limit ①	9999	0–100%	Set the upper limit value. If the feedback value exceeds the setting, the FUP signal is output. The maximum input (20mA/5V/10V) of the measured value (terminal 4) is equivalent to 100%.			
			9999	No function			

Pr. No.	Name	Initial Value	Setting Range	Description	Parameters referred to	Refer to Section
<b>132</b>	PID lower limit	9999	0–100%	Set the lower limit value. If the measured value falls below the setting range, the FDN signal is output. The maximum input (20mA/5V/10V) of the measured value (terminal 4) is equivalent to 100%.	see previous page	
			9999	No function		
<b>133</b>	PID action set point ①	9999	0–100%	Used to set the set point for PID control.		
			9999	Terminal 2 input is the set point.		
<b>134</b>	PID differential time ①	9999	0.01–10.00s	For deviation lamp input, time (Td) required for providing only the manipulated variable for the proportional (P) action. As the differential time increases, greater response is made to a deviation change.		
			9999	No differential control.		
<b>575</b>	Output interruption detection time	1s	0–3600s	The inverter stops operation if the output frequency after PID operation remains at less than the Pr. 576 setting for longer than the time set in Pr. 575.		
			9999	Without output interruption function		
<b>576</b>	Output interruption detection level	0Hz	0–400Hz	Set the frequency at which the output interruption processing is performed.		
<b>577</b>	Output interruption release level	1000%	900–1100%	Set the level (Pr. 577 minus 1000%) to release the PID output interruption function.		

① Pr. 129, Pr. 130, Pr. 133 and Pr. 134 can be set during operation. They can also be set independently of the operation mode.

② Refer to the FR-A700 PLC function programming manual for details of the PLC function.

**PID control basic configuration**

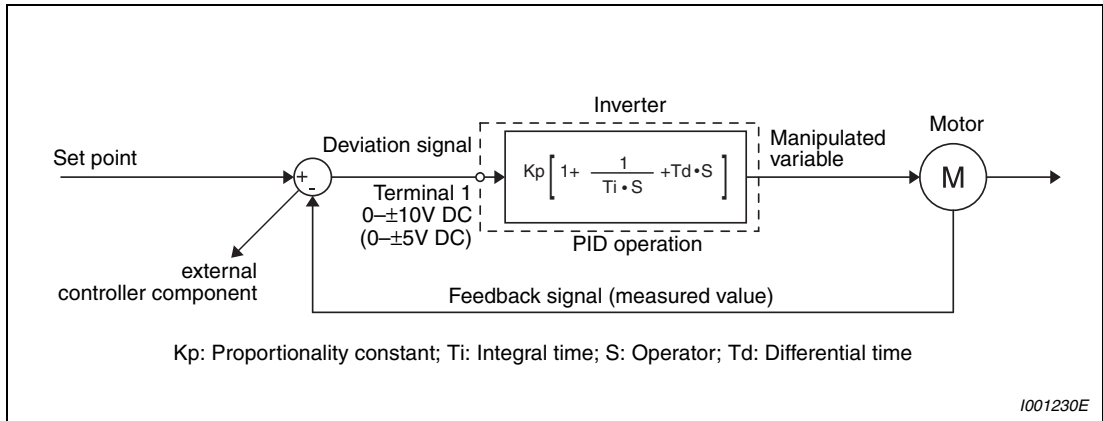

**Fig. 6-237:** System configuration when Pr. 128 = 10, 11 (using an external (PID) controller)

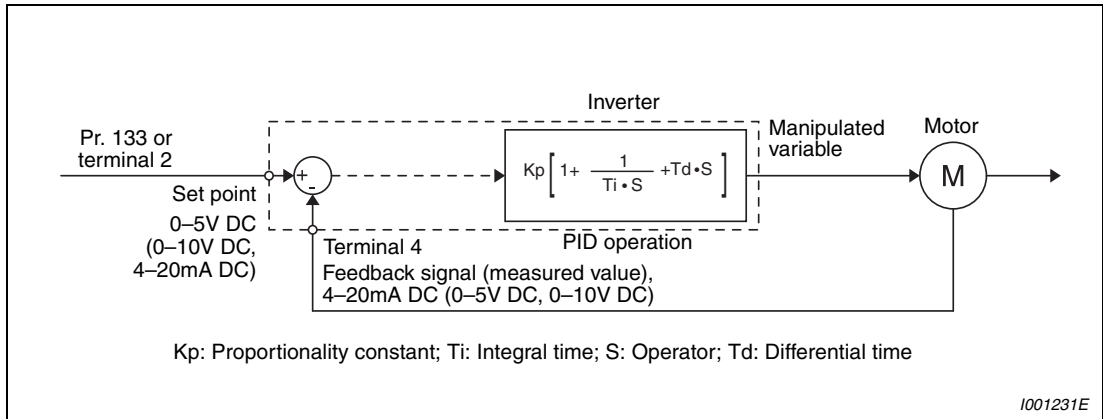

**Fig. 6-238:** System configuration when Pr. 128 = 20 or 21 (set/feedback value at the inverter)

**PI action overview**

A combination of P action (P) and I action (I) for providing a manipulated variable in response to deviation and changes with time.

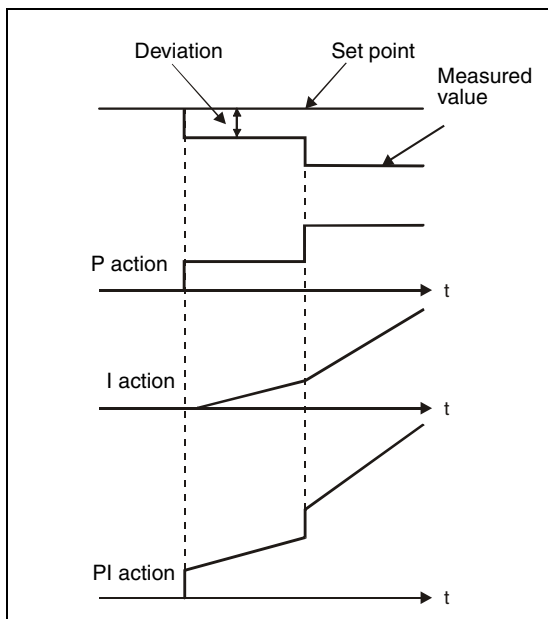
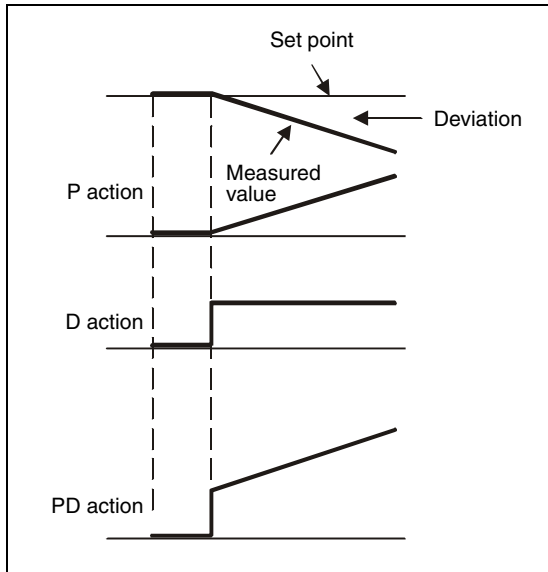

**Fig. 6-239:** Operation example for stepped changes of measured value

I000045C

**PD action**

A combination of P action (P) and differential control action (D) for providing a manipulated variable in response to deviation speed to improve the transient characteristic.

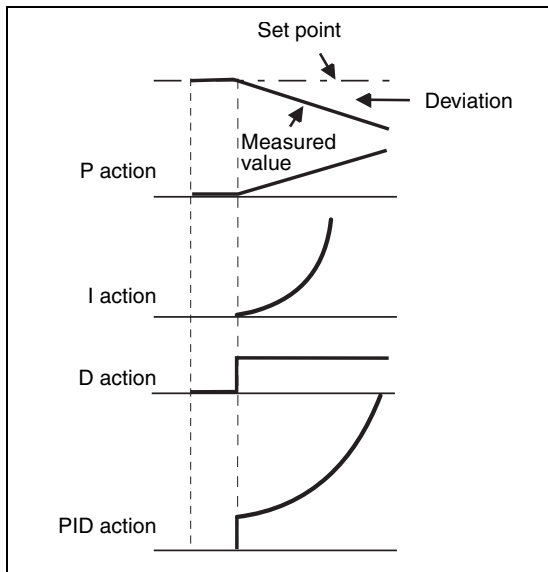

**Fig. 6-240:**  
Operation example for proportional changes of measured value

1000046C

**PID action**

The PI action and PD action are combined to utilize the advantages of both actions for control.

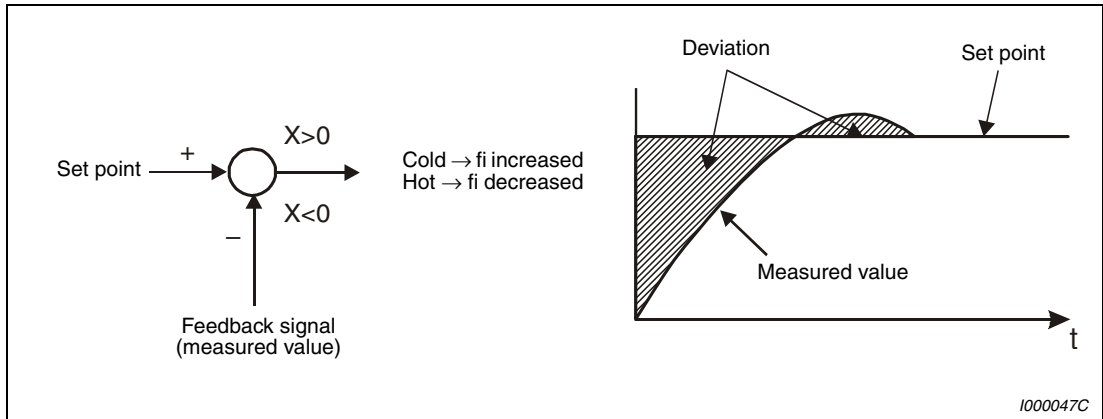

**Fig. 6-241:**  
Operation example for proportional changes of measured value

1001233E

**Reverse action**

Increases the manipulated variable  $f_i$  (output frequency) if deviation  $X = (\text{set point} - \text{measured value})$  is positive, and decreases the manipulated variable if deviation is negative.



**Fig. 6-242: Heater**

**Forward action**

Increases the manipulated variable (output frequency) if deviation  $X = (\text{set point} - \text{measured value})$  is negative, and decreases the manipulated variable if deviation is positive.

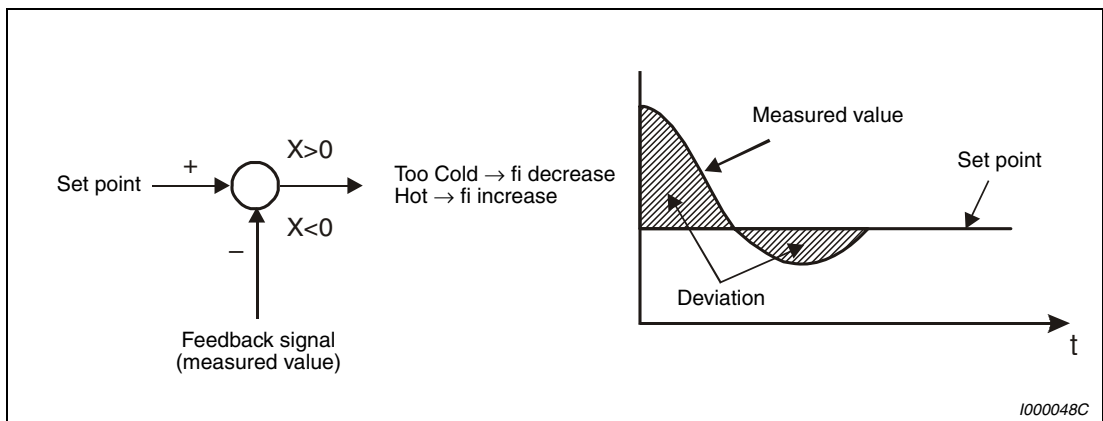

**Fig. 6-243: Cooling**

Relationships between deviation and manipulated variable (output frequency).

	Deviation	
	Positive	Negative
Reverse action	↗	↘
Forward action	↘	↗

**Tab. 6-169: Relationships between deviation and manipulated variable**



**Connection diagram**

The following graphic shows a typical application:

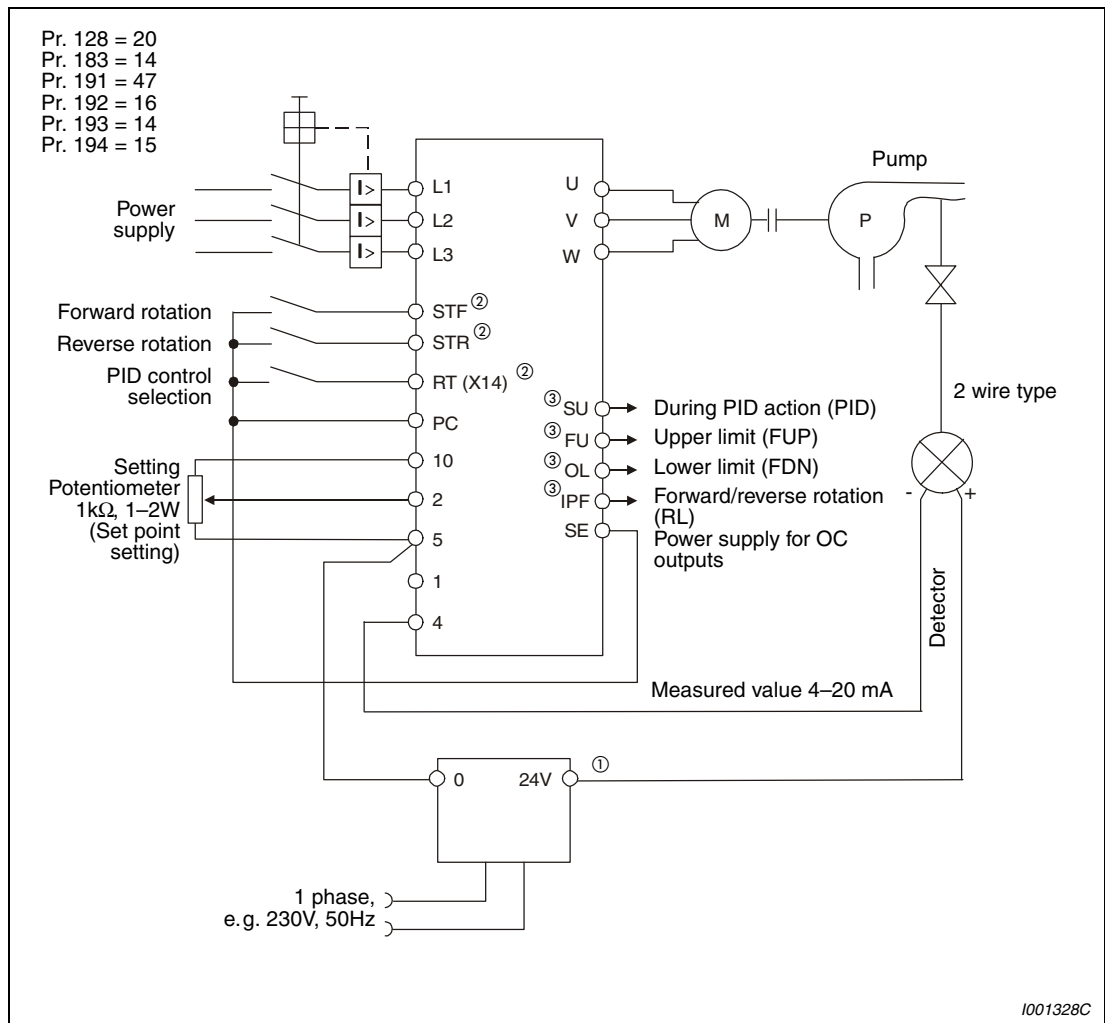

**Fig. 6-244:** Connection diagram in source logic

- ① The power supply must be selected in accordance with the power specifications of the detector used.
- ② The used input signal terminal changes depending on the Pr. 178 to Pr. 189 "Input terminal selection" setting.
- ③ The used output signal terminal changes depending on the Pr. 190 to Pr. 196 "Output terminal selection" setting.

### I/O signals and parameter setting

Turn on the X14 signal to perform PID control. When this signal is off, PID action is not performed and normal inverter operation is performed. (Note that the X14 signal need not be turned on for PID control via LONWORKS communication.)

Enter the set point across inverter terminals 2-5 or into Pr. 133 and enter the measured value signal across inverter terminals 4-5. At this time, set "20" or "21" in Pr. 128.

When entering the calculated deviation signal of an external (PID) controller, enter it across terminals 1-5. At this time, set "10" or "11" in Pr. 128.

Signal	Terminal used	Function	Description	Parameter Setting
X14	Depending on Pr. 179–189	PID control selection	Turn on X14 to perform PID control.	Set "14" to any of Pr. 178 to Pr. 189.
X64		PID forward/reverse action switchover	By turning on X64, forward action can be selected for PID reverse action (Pr. 128 = 10, 20), and reverse action for forward action (Pr. 128 = 11, 21).	Set "64" to any of Pr. 178 to Pr. 189.
2	2	Set point input	Enter the set point for PID control.	Pr. 128 = 20, 21; Pr. 133 = 9999
			0 to 5 V....0 to 100 %	Pr. 73 = 1 ①, 3, 5, 11, 13, 15
			0 to 10 V....0 to 100 %	Pr. 73 = 0, 2, 4, 10, 12, 14
			4 to 20mA0 ....0 to 100%	Pr. 73 = 6, 7
PU	—	Set point input	Set the set value (Pr. 133) from the operation panel or parameter unit.	Pr. 128 = 20, 21; Pr. 133 = 0–100% ④
1	1	Deviation signal input	Input the deviation signal calculated externally.	Pr. 128 = 10 ①, 11
			–5V to +5V....–100% to +100%	Pr. 73 = 2, 3, 5, 7, 12, 13, 15, 17
			–10V to +10V....–100% to +100%	Pr. 73 = 0, 1 ①, 4, 6, 10, 11, 14, 16
4	4	Measured value input	Input the signal from the detector (measured value signal).	Pr. 128 = 20, 21
			4 to 20mA0 ....0 to 100%	Pr. 267 = 0 ①
			0 to 5 V....0 to 100 %	Pr. 267 = 1
			0 to 10 V....0 to 100 %	Pr. 267 = 2
Communication ②	—	Deviation value input	Input the deviation value from LONWORKS, CC-Link communication.	Pr. 128 = 50, 11
		Set value, measured value input	Input the set value and measured value from LONWORKS, CC-Link communication	Pr. 128 = 60, 61

Tab. 6-170: I/O signals and parameter settings (1)

	Signal	Terminal used	Function	Description	Parameter Setting
Output	FUP	Depending on Pr. 190–196	Upper limit output	Output to indicate that the measured value signal exceeded the upper limit value (Pr. 131).	Pr. 128 = 20, 21, 60, 61 Pr. 131 ≠ 9999 Set "15" or "115" to any of Pr. 190–Pr. 196. <sup>③</sup>
	FDN		Lower limit output	Output when the measured value signal falls below the lower limit (Pr.132).	Pr. 128 = 20, 21, 60, 61 Pr. 132 ≠ 9999 Set "14" or "114" to any of Pr. 190–Pr. 196. <sup>③</sup>
	RL		Forward (reverse) rotation direction output	"Hi" is output to indicate that the output indication of the parameter unit is forward rotation (FWD) or "Low" to indicate that it is reverse rotation (REV) or stop (STOP).	Set "15" or "115" to any of Pr. 190–Pr. 196. <sup>③</sup>
	PID		During PID control activated	Turns on during PID control.	Set "47" or "147" to any of Pr. 190–Pr. 196. <sup>③</sup>
	SLEEP		PID output interruption (SLEEP)	Turns on when the PID output interruption function is performed.	Pr. 575 ≠ 9999 Set "70" or "170" to any of Pr. 190–Pr. 196. <sup>③</sup>
	SE	SE	Output terminal common	Common terminal for terminals FUP, FDN, RL, PID and SLEEP	

**Tab. 6-170:** I/O signals and parameter settings (2)

- ① The half-tone screened areas indicate the parameter initial values.
- ② For the setting method via LONWORKS communication, refer to the LONWORKS communication option (FR-A7NL) instruction manual.  
For the setting method via CC-Link communication, refer to the CC-Link communication option (FR-A7NC) instruction manual.
- ③ When "100" or larger value is set to any of Pr. 190 to Pr. 196 "Output terminal function selection", the terminal output has sink logic. (Refer to section 6.14.5 for details.)
- ④ If Pr. 133 is used for the set point signal (setting ≠ 9999) any additional set point signal applied to terminals 2-5 will be ignored.

#### NOTES

Changing the terminal function using any of Pr. 178 to Pr. 189, 190 to Pr. 196 may affect the other functions. Please make setting after confirming the function of each terminal.

When the Pr. 73 and Pr. 267 settings were changed, check the voltage/current input switch setting. Different setting may cause a fault, failure or malfunction. (Refer to page 6-375 for setting.)

**PID control automatic switchover control (Pr. 127)**

For a fast system start-up at an operation start, the system can be started up in normal operation mode only at a start.

When the frequency is set to Pr. 127 "PID control automatic switchover frequency" within the range 0 to 400Hz, the system starts up in normal operation mode from a start until Pr. 127 is reached, and then it shifts to PID control operation mode. Once the system has entered PID control operation, it continues PID control if the output frequency falls to or below Pr. 127.

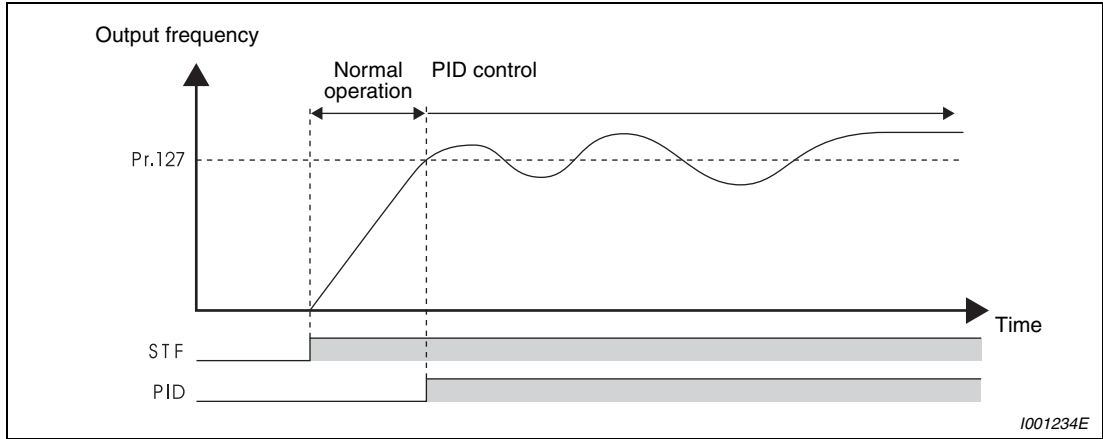

**Fig. 6-245: Automatic switchover to PID control**

**PID output suspension function (SLEEP-Signal, Pr. 575 to Pr. 577)**

The inverter stops operation if the output frequency after PID operation remains at less than the Pr. 576 "Output interruption detection level" setting for longer than the time set in Pr. 575 "Output interruption detection time". This function can reduce energy consumption in the low-efficiency, low-speed range.

When the deviation (= set value – measured value) reaches the PID output shutoff cancel level (Pr. 577 setting – 1000%) while the PID output interruption function is on, the PID output interruption function is canceled and PID control operation is resumed automatically.

While the PID output interruption function is on, the PID output interruption signal (SLEEP) is output. At this time, the inverter running signal (RUN) is off and the PID control operating signal (PID) is on.

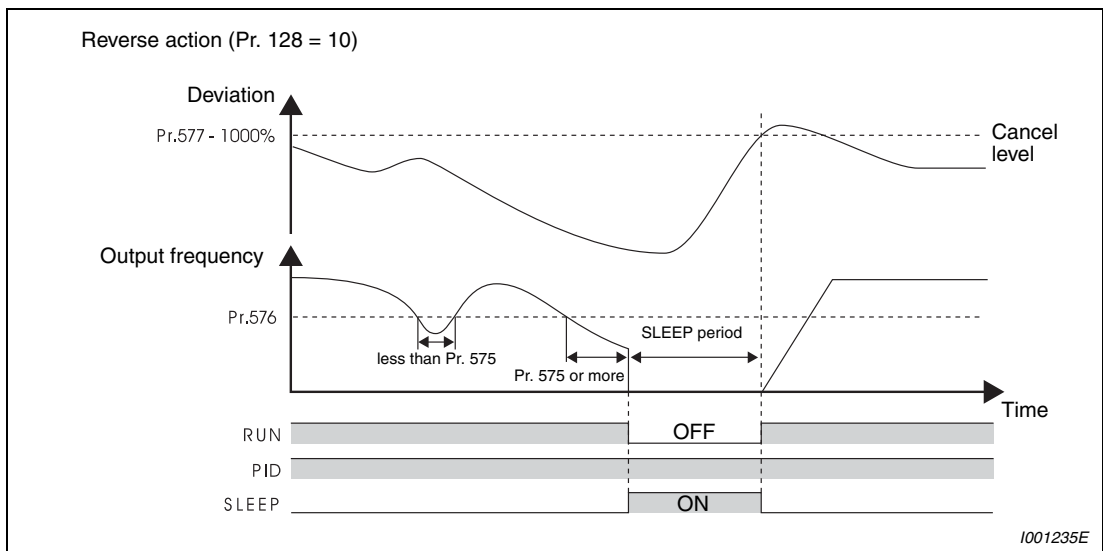

**Fig. 6-246: Output interruption (SLEEP function)**

**PID monitor function**

The PID control set value, measured value and deviation value can be output to the operation panel monitor display and terminal CA, AM.

The deviation monitor can display a negative value on the assumption that 1000 is 0%. (The deviation monitor cannot be output from the terminal CA, AM.)

For the monitors, set the following values to Pr. 52 "DU/PU main display data selection", Pr. 54 "CA terminal function selection", and Pr. 158 "AM terminal function selection".

Parameter	Monitor Description	Minimum Increment	Terminal CA, AM Full Scale	Remarks
52	PID set point	0.1%	100%	For using an external PID controller (Pr. 128 = 10, 11), the monitor value is always displayed as "0".
53	PID measurement value	0.1%	100%	
54	PID deviation value	0.1%	—	Value cannot be output from the terminals AM and CA. The PID deviation value of 0% is displayed as 1000.

**Tab. 6-171: PID monitor function**

**Adjustment procedure**

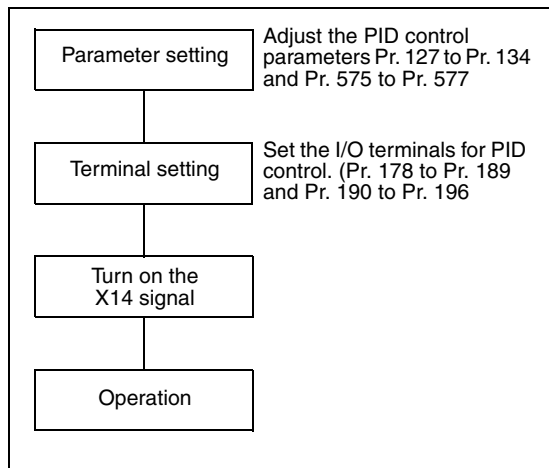
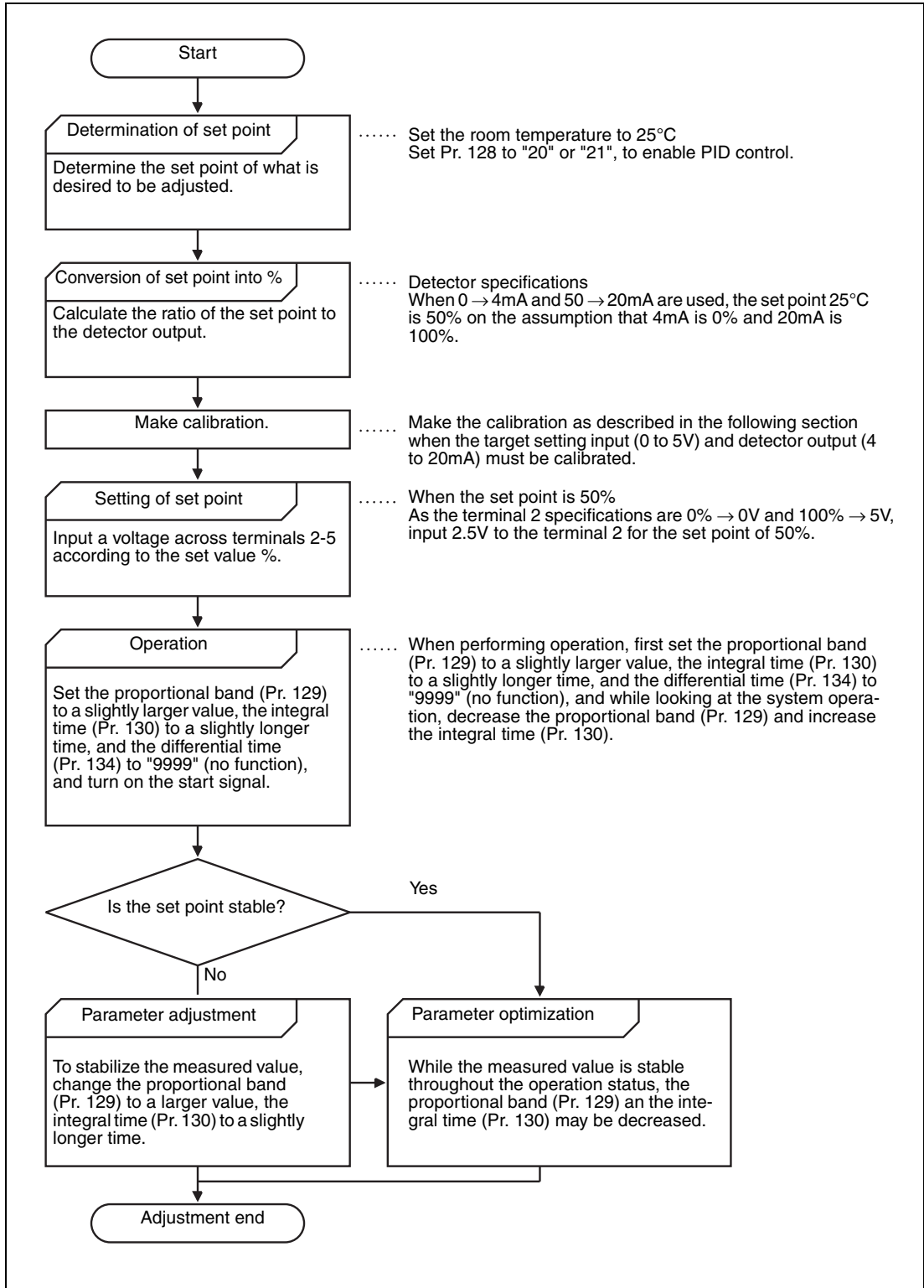

**Fig. 6-247: Adjustment procedure**

**Calibration example**

**Example ▽**

A detector of 4mA at 0°C and 20mA at 50°C is used to adjust the room temperature to 25°C under PID control. The set point is given to across inverter terminals 2-5 (0 to 5V).



**Fig. 6-248: Calibration example**



### Set point input calibration

- ① Apply the input voltage of 0% set point setting (e.g. 0V) across terminals 2-5.
- ② Enter in C2 (Pr. 902) the frequency which should be output by the inverter at the deviation of 0% (e.g. 0Hz).
- ③ In C3 (Pr. 902), set the voltage value at 0%.
- ④ Apply the voltage of 100% set point (e.g. 5V) to across terminals 2-5.
- ⑤ Enter in Pr. 125 the frequency which should be output by the inverter at the deviation of 100% (e.g. 50Hz).
- ⑥ In C4 (Pr. 903), set the voltage value at 100%.

### Process value input calibration

- ① Apply the output current of 0% detector setting (e.g. 4mA) across terminals 4-5.
- ② Make calibration of the process value bias (%) using C6 (Pr. 904).
- ③ Apply the output current of 100% detector setting (e.g. 20mA) across terminals 4-5.
- ④ Make calibration of the process value gain (%) using C7 (Pr. 905).

#### NOTE

The frequency set in C5 (Pr. 904) and Pr. 126 should be the same as set in C2 (Pr. 902) and Pr. 125.

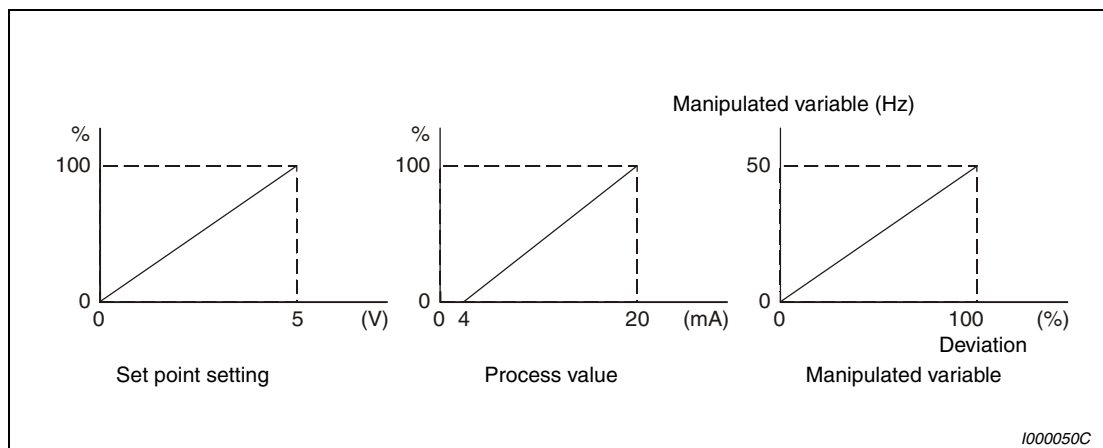

**Fig. 6-249:** Input calibration

**NOTES**

If the multi-speed (RH, RM, RL signal) or jog operation (jog signal) is entered with the X14 signal on, PID control is stopped and multi-speed or jog operation is started.

If the setting is as follows, PID control becomes invalid.

Pr. 79 "Operation mode selection" = "6" (switchover mode)

Pr. 858 "Terminal 4 function assignment", Pr. 868 "Terminal 1 function assignment" = "4" (torque command)

When the Pr. 128 setting is "20" or "21", note that the input across inverter terminals 1-5 is added to the set value across terminals 2-5.

When using terminal 4 (measured value input) and terminal 1 (deviation input) under PID control, set "0" (initial value) in Pr. 858 "Terminal 4 function assignment" and "0" (initial value) in Pr. 868 "Terminal 1 function assignment".

Changing the terminal function using any of Pr. 178 to Pr. 189, Pr. 190 to Pr. 196 may affect the other functions. Please make setting after confirming the function of each terminal.

When PID control is selected, the minimum frequency is the frequency set in Pr. 902 and the maximum frequency is the frequency set in Pr. 903. (Pr. 1 "Maximum frequency" and Pr. 2 "Minimum frequency" settings are also valid.)

The remote operation function is invalid during PID operation.



### 6.24.2 Commercial power supply-inverter switchover function (Pr. 57, Pr. 58, Pr. 135 to Pr. 139, Pr. 159)

The complicated sequence circuit for commercial power supply-inverter switchover is built in the inverter. Hence, merely inputting the start, stop or automatic switchover selection signal facilitates the interlock operation of the switchover magnetic contactor.

Pr. No.	Name	Initial Value	Setting Range	Description	Parameters referred to	Refer to Section	
<b>57</b>	Restart coasting time	9999	0	The following times are coasting times. 00052 or less ..... 0.5s, 00083 to 00250 ..... 1.0s, 00310 to 01800 ..... 3.0s, 02160 or more ..... 5.0s	11 DC injection brake operation time 57 Restart coasting time 58 Restart cushion time 79 Operation mode selection 178-189 Input terminal function selection 190-196 Output terminal function selection	6.13.1 6.16.1 6.16.1 6.22.1 6.14.1 6.14.5	
			01800 or less	0.1 to 5s			Set the waiting time for inverter-triggered restart after an instantaneous power failure.
			02160 or more	0.1 to 30s			
			9999				No restart
<b>58</b>	Restart cushion time	1s	0 to 60s	Set a voltage starting time at restart.			
<b>135</b>	Commercial power-supply switchover sequence output terminal selection	0	0	With commercial power-supply switchover sequence			
			1	Without commercial power-supply switchover sequence			
<b>136</b>	MC switchover interlock time	1s	0-100s	Set the operation interlock time of MC2 and MC3.			
<b>137</b>	Start waiting time	0.5s	0-100s	Set the time slightly longer (0.3 to 0.5s or so) than the time from when the ON signal enters MC3 until it actually turns on.			
<b>138</b>	Commercial power-supply operation switchover selection at an alarm	0	0	Inverter output is stopped (motor coast) at inverter fault.			
			1	Operation is automatically switched to the commercial power-supply operation at inverter fault. (Not switched when an external thermal error occurs)			
<b>139</b>	Automatic switchover frequency between inverter and commercial power-supply operation	9999	0-60Hz	Set the frequency to switch the inverter operation to the commercial power-supply operation. Inverter operation is performed from a start until Pr. 139 is reached, and when the output frequency is at or above Pr. 139, inverter operation is automatically switched to commercial power supply operation.			
			9999	Without automatic switchover			
<b>159</b>	Automatic switchover ON range between commercial power-supply and inverter operation	9999	0-10Hz	Valid during automatic switchover operation (Pr. 139 ≠ 9999) When the frequency command decreases below (Pr. 139 to Pr. 159) after operation is switched from inverter operation to commercial power-supply operation, the inverter automatically switches operation to the inverter operation and operates at the frequency of frequency command. When the inverter start command (STF/STR) is turned off, operation is switched to the inverter operation also.			
			9999	Valid during automatic switchover operation (Pr. 139 ≠ 9999) When the inverter start command (STF/STR) is turned off after operation is switched from the inverter operation to commercial power-supply inverter operation, operation is switched to the inverter operation and the motor decelerates to stop.			

When the motor is operated at 50Hz (or 60Hz), more efficient operation can be performed by the commercial power supply than by the inverter. When the motor cannot be stopped for a long time for the maintenance/inspection of the inverter, it is recommended to provide the commercial power supply circuit.

To switch between inverter operation and bypass operation, an interlock must be provided to stop the motor once and then start it by the inverter in order to prevent the inverter from resulting in an overcurrent alarm. Using the electronic bypass sequence function that outputs the timing signal for operation of the magnetic contactor, a complicated commercial power supply switch-over interlock can be provided by the inverter.

**NOTE**

Commercial operation can not be performed with the Mitsubishi vector motor (SF-V5RU).

**Connecting the magnetic contactors to the inverter**

Parameter setting for source logic:

Pr. 185 = 7, Pr. 192 = 17, Pr. 193 = 18, Pr. 194 = 19

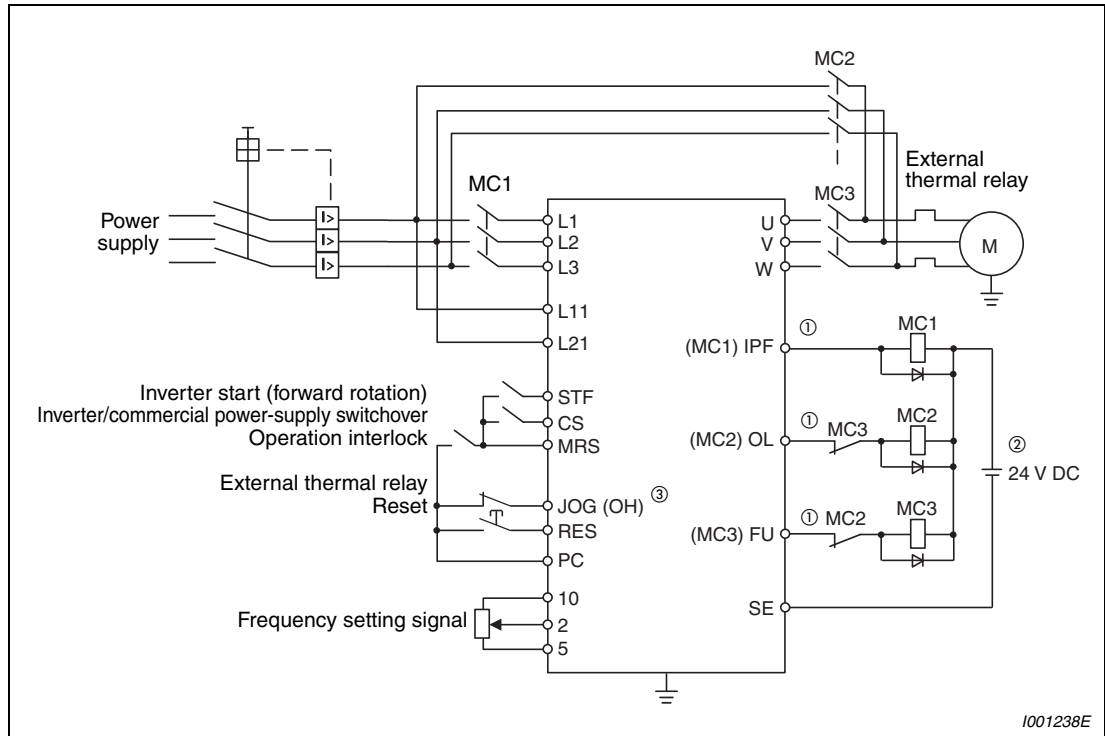

**Fig. 6-250: Connecting the magnetic contactors**

① Take caution for the capacity of the sequence output terminal. The used terminal changes depending on the setting of Pr.190 to Pr. 196 "Output terminal function selection".

Output Terminal	Output Terminal Permissible Load
Inverter open collector output (RUN, SU, IPF, OL, FU)	24V DC, 0.1A
Inverter relay output (A1-C1, B1-C1, A2-B2, B2-C2) Relay output option FR-A7AR	230V AC, 0.3A 30V DC, 0.3A

**Tab. 6-172: Output terminal capacity**

- ② When connecting a DC power supply, insert a protective diode. When connecting an AC power supply, connect relay output option (FR-A7AR) and use a contact output.
- ③ The used terminal changes depending on the setting of Pr.180 to Pr. 189 "Input terminal function selection".

**NOTES**

Use the commercial power supply switchover function in external operation mode. Be sure to connect the other power supply since the function is not performed normally unless the connection terminals R1/L11, S1/L21 are not connected to the other power supply (power supply that does not pass MC1).

Be sure to provide mechanical interlocks for MC2 and MC3. The inverter will be damaged if main supply voltage is connected to the output.

● Operations of magnetic contactors MC1, MC2 and MC3

Magnetic Contactor	Installation Place	Commercial Power Supply Operation	During Inverter Operation	At an Inverter Alarm Occurrence
MC1	Between power supply and inverter input	ON	ON	OFF (ON by reset)
MC2	Between power supply and motor	ON	OFF	OFF (Can be selected using Pr. 138, always OFF when external thermal relay is on)
MC3	Between inverter output and motor	OFF	ON	OFF

**Tab. 6-173: Operations of magnetic contactors**

● The input signals are as indicated below.

Signal	Terminal Used	Function	ON/OFF	MC Operation <sup>⑥</sup>		
				MC1 <sup>⑤</sup>	MC2	MC3
MRS	MRS	Operation enable/disable selection <sup>①</sup>	ON ..... Commercial-inverter operation enabled	ON	—	—
			OFF ... Commercial-inverter operation disabled	ON	OFF	No change
CS	CS	Inverter/commercial switchover <sup>②</sup>	ON ..... Inverter operation	ON	OFF	ON
			OFF ... Commercial power supply operation	ON	ON	OFF
STF (STR)	STF (STR)	Inverter operation command (Invalid for commercial operation) <sup>③</sup>	ON ..... Forward rotation (reverse rotation)	ON	OFF	ON
			OFF ... Stop	ON	OFF	ON
OH	Set "7" to any of Pr. 180 to Pr. 189.	External thermal relay input	ON ..... Motor normal	ON	—	—
			OFF ... Motor abnormal	ON	OFF	OFF
RES	RES	Operating status initialization <sup>④</sup>	ON ..... Initialization	No change	OFF	No change
			OFF ... Normal operation	ON	—	—

**Tab. 6-174: I/O signals**

- ① Unless the MRS signal is turned on, neither commercial power supply operation nor inverter operation can be performed.
- ② The CS signal functions only when the MRS signal is on.
- ③ STF (STR) functions only when both the MRS signal and CS signal are on.
- ④ The RES signal enables reset input acceptance selection using Pr. 75 "Reset selection/disconnected PU detection/PU stop selection".
- ⑤ MC1 turns off when an inverter alarm occurs.
- ⑥ MC operation  
 —: Inverter operation (MC2 is off and MC3 is on)  
 Commercial power supply operation (MC2 is on and MC3 is off)  
 No change: The status before the signal turns on or off is held.

● The output signals are as indicated below:

Signal	Terminal Used (Pr. 190 to Pr. 196 setting)	Description
MC1	17	Control signal output of inverter input side magnetic contactor MC1
MC2	18	Control signal output of inverter output side magnetic contactor MC2
MC3	19	Control signal output of commercial power supply operation magnetic contactor MC3

**Tab. 6-175: Output signals**

**Commercial power supply-inverter switchover operation sequence**

- Operation sequence example when there is no automatic switchover sequence (Pr. 139 = 9999)

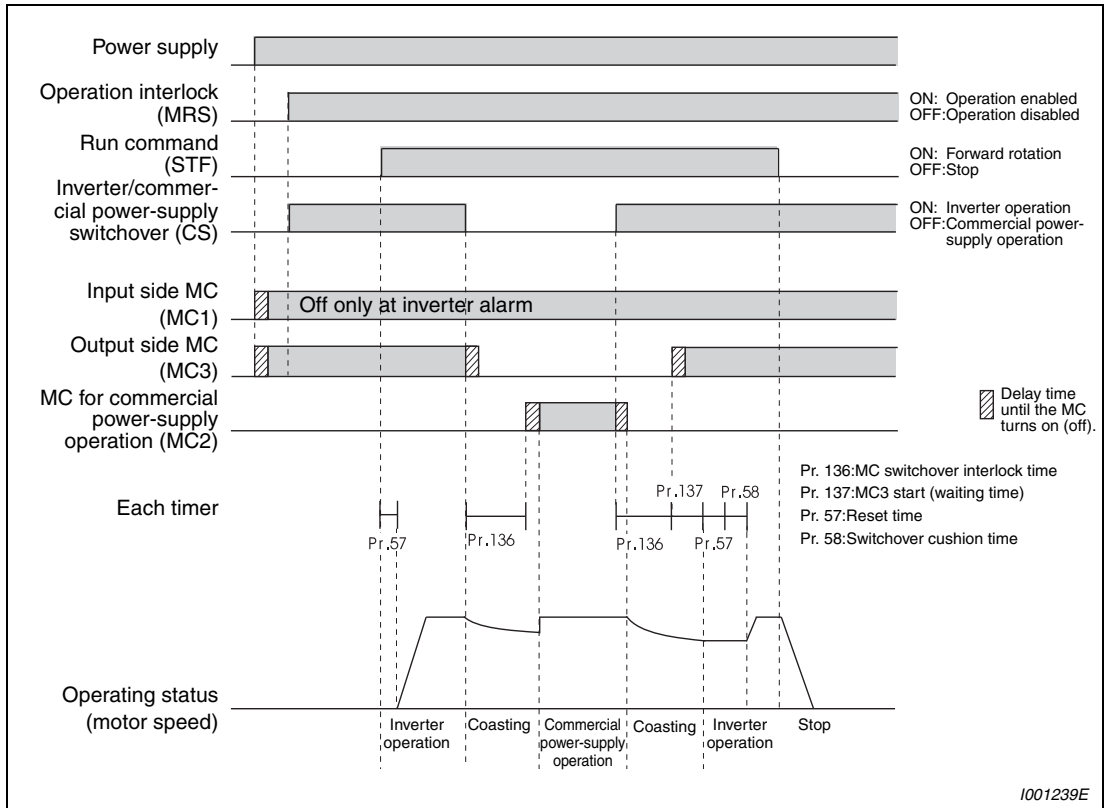

**Fig. 6-251:** Signal timing when there is no automatic switchover sequence

- Operation sequence example when there is automatic switchover sequence (Pr. 139 ≠ 9999, Pr. 159 = 9999)

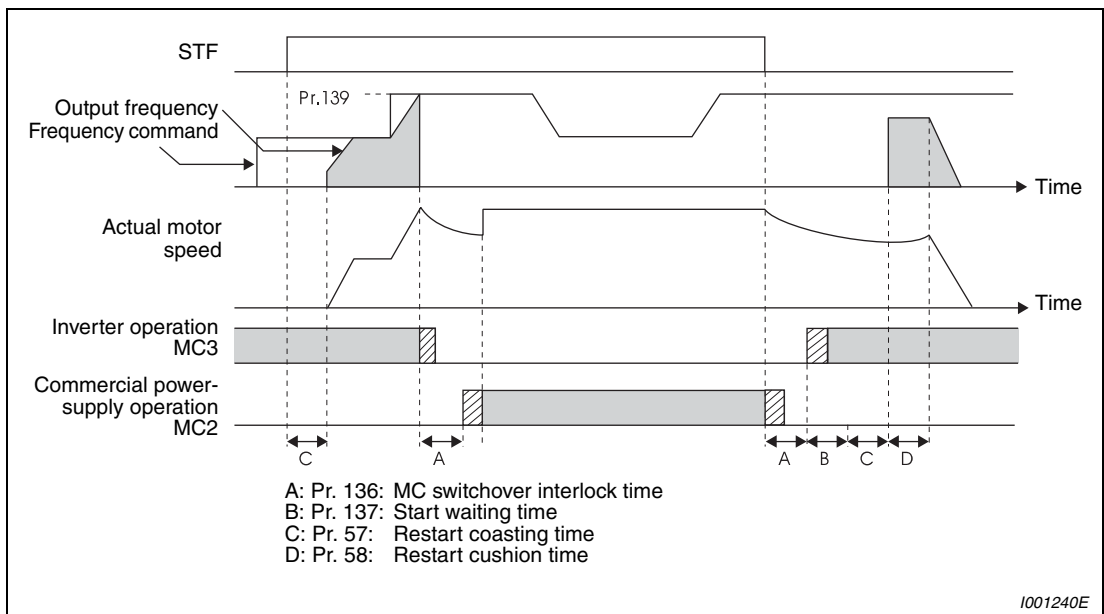

**Fig. 6-252:** Signal timing when there is automatic switchover sequence

- Operation sequence example when there is automatic switchover sequence (Pr. 139 ≠ 9999, Pr. 159 ≠ 9999)

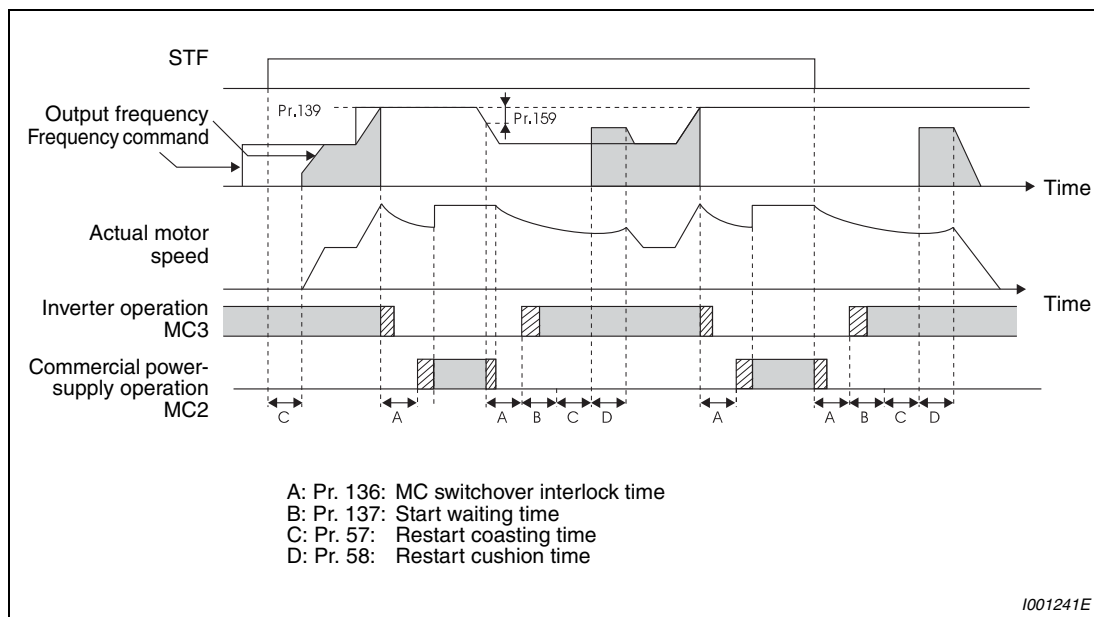

**Fig. 6-253:** Signal timing when there is automatic switchover sequence

### Operation procedure

- ① Turn the power supply on.
- ② Set the parameters.
  - Pr. 135 = 1 (Commercial power supply operation enabled.)
  - Pr. 136 = 2.0s
  - Pr. 137 = 1.0s (Set the time longer than the time from when MC3 actually turns on until the inverter and motor are connected. If the time is short, a restart may not function properly.)
  - Pr. 57 = 0.5s
  - Pr. 58 = 0.5s (Be sure to set this parameter when commercial power supply operation is switched to inverter operation.)
- ③ Start inverter operation.
- ④ The switchover to commercial power supply operation is performed by a command or when the switchover frequency is reached.
- ⑤ When the Stop command is applied the system switches to inverter operation and the motor is decelerated under control.

**Signal ON/OFF after parameter setting**

	MRS	CS	STF	MC1	MC2	MC3	Remarks
Power supply ON	OFF (OFF)	OFF (OFF)	OFF (OFF)	OFF → ON (OFF → ON)	OFF (OFF)	OFF → ON (OFF → ON)	External operation mode (PU operation mode) (refer to note 2)
At start (inverter)	OFF → ON	OFF → ON	OFF → ON	ON	OFF	ON	
At constant speed (commercial power supply)	ON	ON → OFF	ON	ON	OFF → ON	ON → OFF	MC2 turns on after MC3 turns off (coasting status during this period) Waiting time 2s
Switched to inverter for deceleration (inverter)	ON	OFF → ON	ON	ON	ON → OFF	OFF → ON	MC3 turns on after MC2 turns off (coasting status during this period) Waiting time 4s
Stop	ON	ON	ON → OFF	ON	OFF	ON	

**Fig. 6-254:** Signals after parameter setting**NOTES**

Connect the control power supply (R1/L11, S1/L21) in front of input side MC1. If the control power supply is connected behind input side MC1, the commercial power supply-inverter switchover sequence function is not executed.

The commercial power supply-inverter switchover sequence function is valid only when Pr. 135 = 1 in the external operation or combined operation mode (PU speed command, external operation command Pr. 79 = 3). When Pr. 135 = 1 in the operation mode other than the above, MC1 and MC3 turn on.

When the MRS and CS signals are on and the STF (STR) signal is off, MC3 is on, but when the motor was coasted to a stop from commercial power supply operation last time, a start is made after the time set to Pr. 137 has elapsed.

Inverter operation can be performed when the MRS, STF (STR) and CS signals turn on. In any other case (MRS signal-ON), commercial power supply operation is performed.

When the CS signal is turned off, the motor switches to commercial power supply operation. However, when the STF (STR) signal is turned off, the motor is decelerated to a stop in the inverter operation mode.

When both MC2 and MC3 are off and either MC2 or MC3 is then turned on, there is a waiting time set in Pr. 136.

If commercial power supply-inverter switchover sequence is made valid (Pr. 135 = 1), the Pr. 136 and Pr. 137 settings are ignored in the PU operation mode. The input terminals (STF, CS, MRS, OH) of the inverter return to their normal functions.

When the commercial power supply-inverter switchover sequence function (Pr. 135 = 1) and PU operation interlock function (Pr. 79 = 7) are used simultaneously, the MRS signal is shared by the PU operation external interlock signal unless the X12 signal is assigned. (When the MRS and CS signals turn on, inverter operation is enabled)

Changing the terminal function using any of Pr. 178 to Pr. 189, 190 to Pr. 196 may affect the other functions. Please make setting after confirming the function of each terminal.

### 6.24.3 Load torque high speed frequency control (Pr. 4, Pr. 5, Pr. 270 to Pr. 274)

Load torque high speed frequency control is a function which automatically sets the operational maximum frequency according to the load. More specifically, the magnitude of the load is judged according to the average current at a certain time after starting to perform operation at higher than the preset frequency under light load.

This function is designed to increase speed automatically under light load, for example to minimize the incoming/outgoing time in a multi-story parking lot.

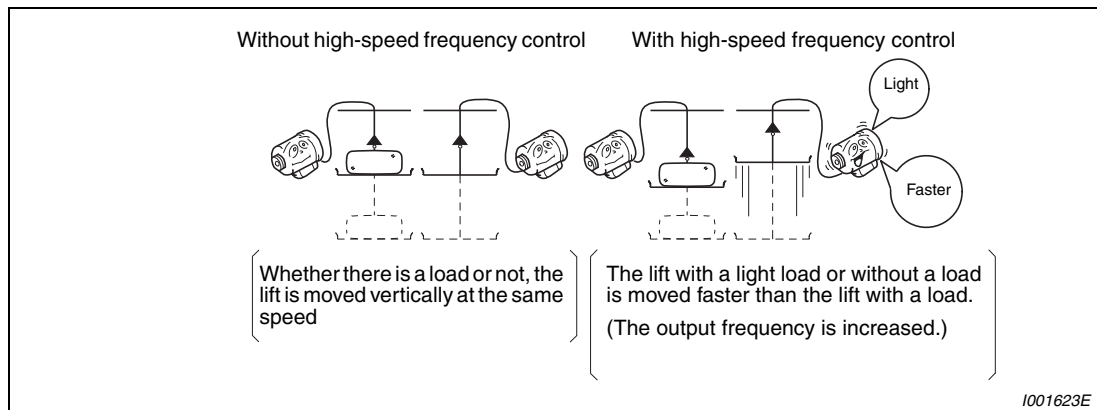

**Fig. 6-255:** Reduction of vibrations in vertical motion applications



Pr. No.	Name	Werks-einstellung	Initial Value	Description	Parameters referred to	Refer to Section
<b>4</b>	Multi-speed setting (high speed)	50Hz	0–400Hz	Set the higher-speed frequency	4–6 Multi-speed setting 24–27 Remote function selection 59 Operation mode selection 79 PID action selection 128 Input terminal function selection 178–189	6.10.1 6.10.4 6.22.1 6.24.1 6.14.1
<b>5</b>	Multi-speed setting (middle speed)	30 Hz	0–400 Hz	Set the lower-speed frequency		
<b>270</b>	Stop-on contact/load torque high-speed frequency control selection	0	0	Normal operation		
			1	Stop-on-control (refer to section 6.13.4)		
			2	Load torque high speed frequency control		
			3	Stop-on-contact (refer to section 6.13.4) + load torque high speed frequency control		
			11 ②	Stop-on-control (refer to section 6.13.4)		
13 ②	Stop-on-contact (refer to section 6.13.4) + load torque high speed frequency control	E.OLT ( Stall prevention stop) detection is inactive during stop-on-contact control				
<b>271</b>	High-speed setting maximum current	50%	0–220% ①	Set the upper and lower limits of the current at high and middle speeds.		
<b>272</b>	Untere Stromgrenze für mittlere Frequenz	100%	0–220% ①			
<b>273</b>	Current averaging range	9999	0–400Hz	Average current during acceleration from (Pr. 273 × 1/2) Hz to (Pr. 273) Hz can be achieved.		
			9999	Average current during acceleration from (Pr. 5 × 1/2) Hz to (Pr. 5) Hz is achieved.		
<b>274</b>	Current averaging filter time constant	16	1–4000	Set the time constant of the primary delay filter relative to the output current. The time constant [ms] is 0.75 × Pr. 274 and the initial value is 12ms. A larger setting provides higher stability but poorer response.		

① When Pr. 570 Multiple rating setting ≠ "2", performing all parameter clear and inverter reset changes the setting range. (Refer to section 6.7.5).

② Pr. 270 can be set to "11" or "13" in frequency inverters of the FR-A700 EC series manufactured in December 2010 or later (refer to section 1.2).

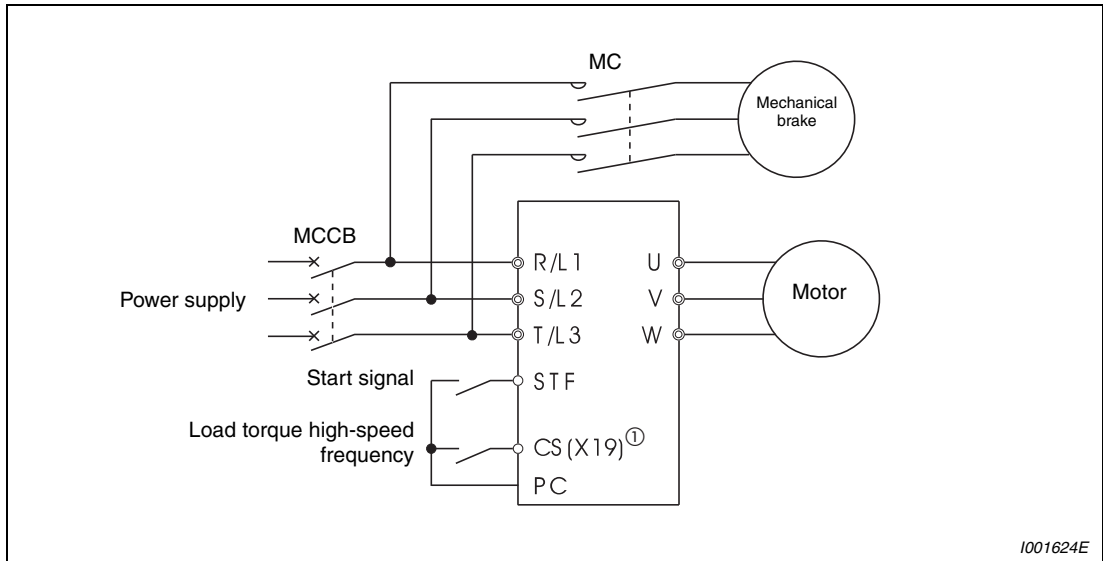
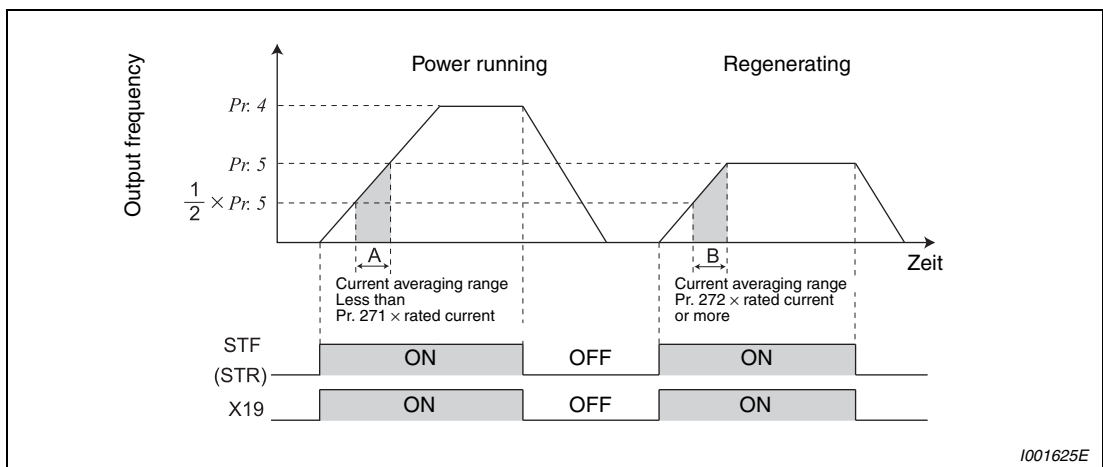

**Fig. 6-256:** Connection diagram (source logic, Pr. 186 = 19)

① The used terminal changes according to the Pr. 180 to Pr. 189 (input terminal function selection) settings

**Load torque high speed frequency control setting**

- Set "2 or 3" in Pr. 270 "Stop-on contact/load torque high-speed frequency control selection."
- When operating with the load torque high speed frequency function selection signal (X19) on, the inverter automatically changes the maximum frequency within the setting range of Pr. 4 "Multi-speed setting (high speed)" and Pr. 5 according to the magnitude of the average current during the time to accelerate from 1/2 of the frequency set in Pr. 5 "Multi-speed setting (middle speed)" to the frequency set in Pr. 5 .
- Set "19" in Pr. 178 to Pr. 189 (input terminal function selection) and assign the X19 signal function to the input terminal.
- This function can be made valid only in the external operation mode.
- This control can be activated at every start.



**Fig. 6-257:** Output frequency vs. average current

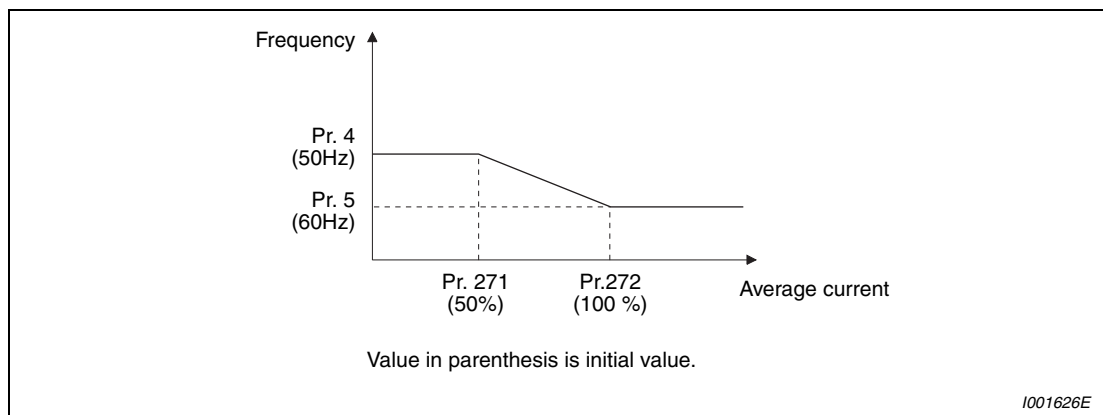

**Fig. 6-258: Parameter 271 and 272**

### Operation of load torque high speed frequency control setting

When the average current of the current averaging range (above chart A) during operation with the X19 signal on is less than the "rated inverter current  $\times$  Pr. 271 setting (%)", the maximum frequency automatically becomes the Pr. 4 "Multi-speed setting (high speed)" setting value.

When the average current of the current averaging range (above chart B) during operation with the X19 signal on is more than the "rated inverter current  $\times$  Pr. 272 setting (%)", the maximum frequency automatically becomes the Pr. 5 "Multi-speed setting (middle speed)" setting value.

The current averaging range can be set between 1/2 frequency of the Pr. 273 setting value and Pr. 273 set frequency.

### NOTES

When the current averaging range includes the constant power range, the output current may become large in the constant power range

When the average current value in the current averaging range is small, deceleration time becomes longer as the running frequency increases.

The maximum output frequency is 120Hz. The output frequency is 120Hz even when the setting is above 120Hz.

The fast-response current limit function is made invalid.

When the average current during acceleration is too small, it may be judged as regeneration and the maximum frequency becomes the setting of Pr. 5.

Changing the terminal function using any of Pr. 178 to Pr. 189 may affect the other functions. Please make setting after confirming the function of each terminal.

The load torque high speed frequency function is made invalid in the following operation conditions.

PU operation (Pr. 79) , PU+external operation (Pr. 79) , JOG operation (JOG signal) , PID control function operation (X14 signal), remote setting function operation (Pr. 59), orientation control function operation, multi-speed setting (RH, RM, RL signal) , 16 bit digital input option (FR-A7AX)



### CAUTION:

**When the load is light, the motor may suddenly accelerate to 120Hz maximum, causing hazard. Securely provide mechanical interlock on the machine side to perform.**

**6.24.4 Droop control (Pr. 286 to Pr. 288)** Magnetic flux Sensorless Vector

This function is designed to balance the load in proportion to the load torque to provide the speed drooping characteristic under advanced magnetic flux vector control, real sensorless vector control and vector control.

This function is effective for balancing the load when using multiple inverters.

Pr. No.	Name	Initial Value	Setting Range	Description	Parameters referred to	Refer to Section
<b>286</b>	Droop gain	0%	0	Droop control is invalid (Normal operation)	1 Maximum frequency PID control	6.8.1
			0.1–100%	Droop control is valid. Drooping amount at the rated torque as a percentage with respect to the rated motor frequency.		
<b>287</b>	Droop filter time constant	0.3s	0–1s	Time constant of the filter applied on the torque current.		
<b>288</b>	Droop function activation selection	0	0	Droop control is not exercised during acceleration/ deceleration.		
			1	Droop control is always exercised during operation. (with 0 limit)		
			2	Droop control is always exercised during operation. (without 0 limit)		
			10	Droop control is not exercised during acceleration/ deceleration. (Motor speed is referenced)		
			11	Droop control is always exercised during operation. (Motor speed is referenced)		

The output frequency is changed according to the magnitude of torque amount current under advanced magnetic flux vector control, real sensorless vector control and vector control. The drooping amount at the rated torque is set by the droop gain as a percentage using the rated frequency (Motor speed when Pr. 288 = "10, 11") as a reference.

The maximum droop compensation frequency is 120Hz.

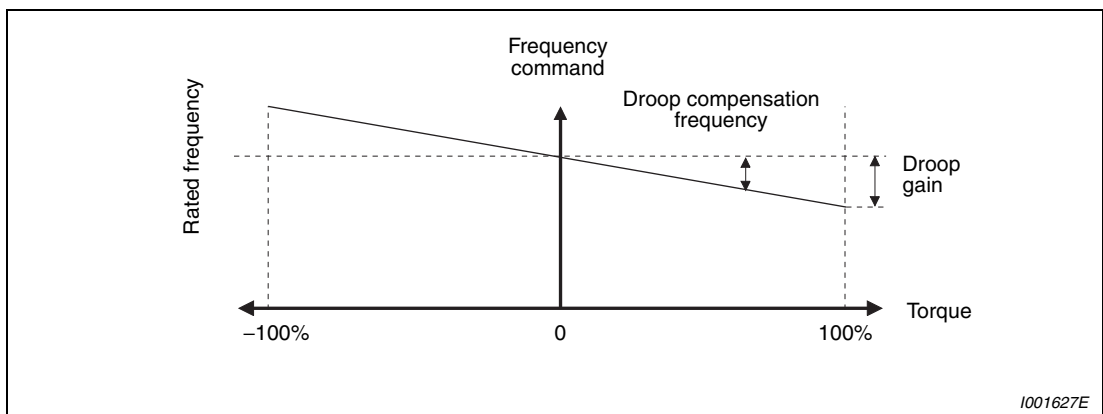

**Fig. 6-259: Droop control**

When Pr. 288 = "0 to 2", or under advanced magnetic flux vector control, the droop compensation frequency can be found with the following formula.

$$\text{Droop compensation frequency} \square \frac{\text{Torque current after filtering}}{\text{Rated value of base frequency}} \times \frac{\text{Rated motor frequency} \times \text{Droop gain}}{100}$$

Use the following formula for the droop compensation frequency when Pr. 288 = "10 or 11".

$$\text{Droop compensation frequency} \square \frac{\text{Torque current after filtering}}{\text{Rated value of base frequency}} \times \frac{\text{Motor speed} \times \text{Droop gain}}{100}$$

**NOTES**

Set the droop gain to about the rated slip of the motor.

$$\text{Rated slip} \square \frac{\text{Synchronous speed at base frequency} \square \text{Rated speed}}{\text{Synchronous speed at base frequency}} \times 100 [\%]$$

**Limit the frequency after droop compensation (0 limit)**

Setting Pr. 288 under real sensorless vector control or vector control can limit the frequency command when the frequency after droop compensation is negative.

Pr. 288 setting	Description	
	Under advanced magnetic flux vector control	Under real sensorless vector control or vector control
0 (Initial value)/ 10	Droop control is not exercised during acceleration/deceleration. Note that the frequency command after droop control is limited at 0.5Hz when the frequency command after droop control is negative. Droop compensation amount is determined using the rated motor frequency as reference.	Droop control is not exercised during acceleration/deceleration. Note that the frequency command is limited at 0Hz when the frequency command after droop control is negative. When Pr. 288 = "10", droop compensation amount is determined using the motor speed as reference.
1/11		Droop control is always exercised during operation. Note that the frequency command is limited at 0Hz when the frequency command after droop control is negative. When Pr. 288 = "11", droop compensation amount is determined using the motor speed as reference.
2		Droop control is always exercised during operation. Note that under vector control, the frequency command is not limited at 0Hz even when the frequency command after droop control is negative. (The frequency command is limited at 0Hz under real sensorless vector control.)

**Tab. 6-176: Setting of parameter 288**

**NOTE**

The maximum value of frequency after droop compensation is either 120Hz or Pr. 1 "Maximum frequency", whichever is smaller.

### 6.24.5 Frequency setting by pulse train input (Pr. 291, Pr. 384 to Pr. 386)

The inverter speed can be set by inputting pulse train from terminal JOG.

Pr. No.	Name	Initial Value	Setting Range	Description	Parameters referred to	Refer to Section
<b>291</b>	Pulse train input selection	0	0	Terminal JOG	—	
			1	Pulse train input		
<b>384</b>	Input pulse division scaling factor	0	0	Pulse train input invalid		
			1–250	Indicates division scaling factor to the input pulse and the frequency resolution to the input pulse changes according to the value.		
<b>385</b>	Frequency for zero input pulse	0Hz	0–400Hz	Set the frequency when the input pulse is 0 (bias).		
<b>386</b>	Frequency for maximum input pulse	50Hz	0–400Hz	Set the frequency when the input pulse is maximum (gain).		

#### Pulse train input selection (Pr. 291)

Setting any of "1, 11, 21, 100" in Pr. 291 "Pulse train input selection" and a value other than "0" in Pr. 384 "Input pulse division scaling factor" switches terminal JOG to pulse train input terminal and frequency setting of the inverter can be performed. (The initial value is JOG signal) Pulse train input of maximum of 100k pulse/s is enabled.

Output specifications (high speed pulse train output or FM output) of terminal FM can be selected using Pr. 291.

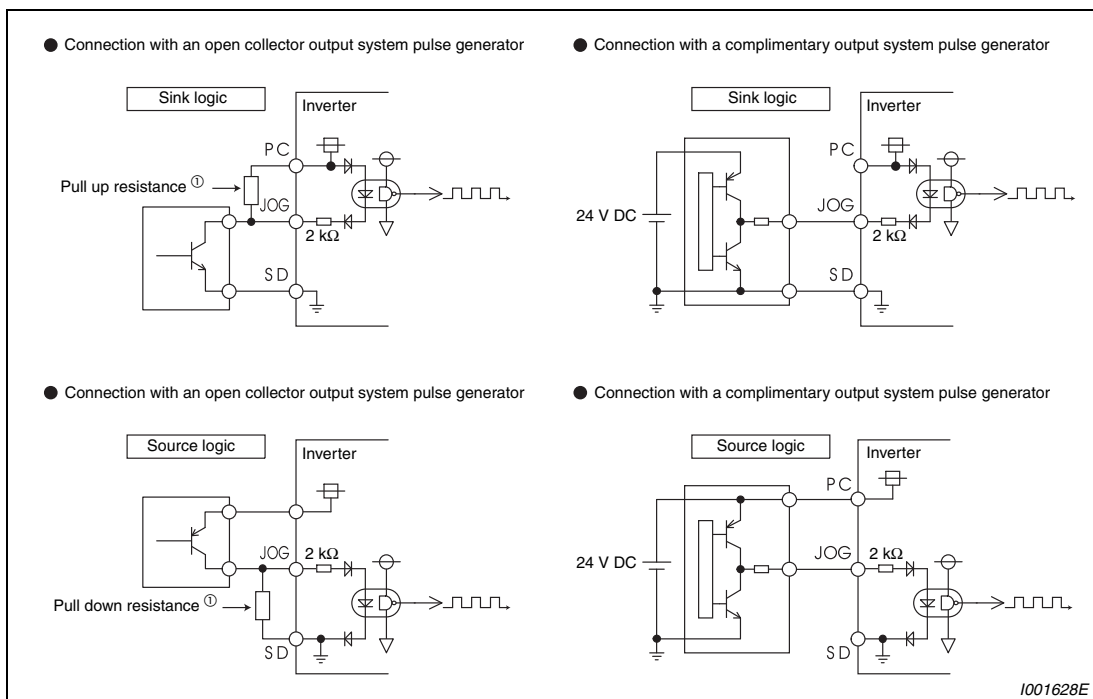

**Fig. 6-260: Pulse train input**

① When the wiring length of the open collector output connection is long, input pulse can not be recognized because of a pulse shape deformation due to the stray capacitances of the wiring. When wiring length is long (10m or more of 0.75mm<sup>2</sup> twisted cable is recommended), connect an open collector output signal and power supply using a pull up or pull down resistance. The reference of resistance value to the wiring length is as in the table below.

Wiring Length	Less than 10m	10 to 50 m	50 to 100 m
Pull up/down resistance	Not necessary	1kΩ	470Ω
Load current (for reference)	10mA	35mA	65mA

**Tab. 6-177:** resistance values for pull up and pull down resistances

Stray capacitances of the wiring greatly differ according to the cable type and cable laying, the above cable length is not a guaranteed value.

When using a pull up resistance, check the permissible power of the resistor and permissible load current of output transistor and use them within a permissible range.

**NOTES**

When pulse train input is selected, a function assigned to terminal JOG using Pr. 185 JOG terminal function selection is made invalid.

When Pr. 419 Position command source selection = "2" (conditional position pulse train command by inverter pulse train input), JOG terminal serves as conditional position pulse train terminal regardless of the Pr. 291.

**Pulse train input specifications**

Item	Specifications	
Available pulse method	<ul style="list-style-type: none"> <li>• Open collector output</li> <li>• Complimentary output (power supply voltage 24V)</li> </ul>	
H input level	20V or more (voltage between JOG-SD)	
L input level	5V or less (voltage between JOG-SD)	
Maximum input pulse rate	100kpps	
Minimum input pulse width	2.5μs	
Input resistance/load current	2kΩ (typ.)/10mA (typ.)	
Maximum wiring length (reference value)	Open collector output system	10m (0.75 mm <sup>2</sup> / twisted pair)
	Complimentary output system	100m (output resistance 50Ω) ①
Detection resolution	1/3750	

**Tab. 6-178:** Pulse train input specification

① The wiring length of complementary output depends on the output wiring specifications of complementary output device. Stray capacitances of the wiring greatly differ according to the cable type and cable laying, the maximum cable length is not a guaranteed value.

**NOTE**

When pulse train input is selected, a function assigned to terminal JOG using Pr. 185 "JOG terminal function selection" is made invalid.

### Adjustment of pulse train input and frequency (Pr. 385, Pr. 386 )

Frequency for zero input pulse can be set using Pr. 385 "Frequency for zero input pulse" and frequency at maximum input pulse can be set using Pr. 386 "Frequency for maximum input pulse".

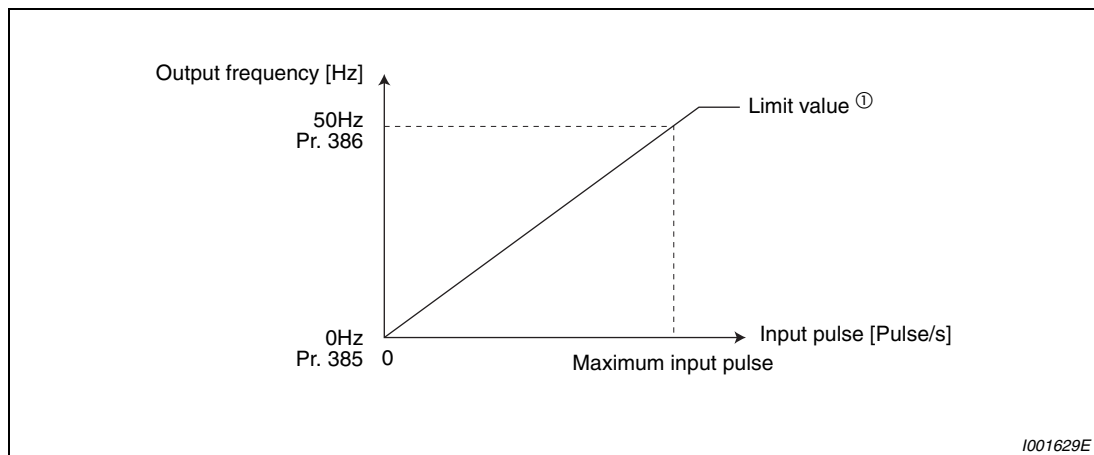

**Fig. 6-261:** Adjustment of pulse train input

- ① Limit value can be calculated from the following formula.  
 $(Pr. 386 - Pr. 385) \times 1.1 + Pr. 385$

### Calculation method of division scaling factor of input pulse (Pr. 384 )

Maximum input pulse can be calculated from the following formula using Pr. 384 "Input pulse division scaling factor".

Maximum of input pulse (pulse/s) = Pr. 384 × 400 (maximum of 100kpulse/s)  
 Detectable pulse = 11.45 pulse/s

#### Example ▽

When you want to operate at 0Hz when pulse train input is zero and operate at 30Hz when pulse train is 4000 pulse/s, set parameters as below.

Pr. 384 = 10 (maximum input pulse 4000 pulse/s)

Pr. 385 = 0 Hz, Pr. 386 = 30 Hz (pulse train limit value is 33 Hz)

△

#### NOTE

The priorities of the frequency commands by the external signals are "jog operation > multi-speed operation > terminal 4 analog input > pulse train input > terminal 2 analog input".



**6.24.6 Encoder feedback control (Pr. 144, Pr. 285, Pr. 359, Pr. 367 to Pr. 369)** V/F Magnetic flux

This controls the inverter output frequency so that the motor speed is constant to the load variation by detecting the motor speed with the speed detector (encoder) to feed it back to the inverter. For this function the Option FR-A7AP is necessary.

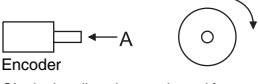
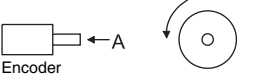
Pr. No.	Bedeutung	Initial Value	Setting Range	Description	Parameters referred to	Refer to Section
<b>144</b>	Speed setting switchover	4	0/2/4/6/8/10/102/104/106/108/110	Set the number of motor poles when performing encoder feedback control under V/f control.	81	Number of motor pole
<b>285</b>	Overspeed detection frequency (Speed deviation excess detection frequency) ①	9999	0-30Hz	If (detected frequency) - (output frequency) > Pr. 285 during encoder feedback control, the inverter alarm (E.MB1) is provided.		
			9999	Overspeed is not detected.		
<b>359</b>	Encoder rotation direction ②	1	0	 <p>Encoder Clockwise direction as viewed from A is forward rotation.</p>		
			1	 <p>Encoder Counter clockwise direction as viewed from A is forward rotation</p>		
<b>367</b>	Speed feedback range ②	9999	0-400Hz	Set the region of speed feedback control.		
			9999	Encoder feedback control is invalid		
<b>368</b>	Feedback gain ②	1	0-100	Set when the rotation is unstable or response is slow		
<b>369</b>	Number of encoder pulses ②	1024	0-4096	Set the number of pulses of the encoder before multiplied by four.		

① When exercising vector control with the FR-A7AP, this parameter changes to excessive speed deviation detection frequency.

② The above parameters can be set when the FR-A7AP (option) is mounted.

**Setting before the operation (Pr. 144, Pr. 359, Pr. 369)**

When performing encoder feedback control under V/f control, set the number of motor poles in Pr. 144 "Speed setting switchover" according to the motor used. Under advanced magnetic flux vector control, the Pr. 81 "Number of motor poles" setting is made valid and the Pr. 144 setting is invalid.

Set the rotation direction and the number of encoder pulses of the encoder using Pr. 359 "Encoder rotation direction" and Pr. 369 "Number of encoder pulses".

**NOTES**

When "0, 10, 110" is set in Pr. 144 and the inverter is started, error E.1 to E.3 occurs.

When "102, 104, 106, 108" is set in Pr. 144, the value subtracting 100 is set as the number of motor poles.

**CAUTION:**

- *If the number of motor poles is wrong, control at correct speed can not be performed. Always check before operation.*
- *Encoder feedback control can not be performed when the setting of encoder rotation direction is wrong. (Inverter operation is enabled.) Encoder rotation direction can be checked with the rotation direction display of the parameter unit.*

**Selection of encoder feedback control (Pr. 367)**

When a value other than "9999" is set in Pr. 367 "Speed feedback range", encoder feedback control is valid.

Using the set point (frequency at which stable speed operation is performed) as reference, set the higher and lower setting range. Normally, set the frequency converted from the slip amount (r/min) of the rated motor speed (rated load). If the setting is too large, response becomes slow.

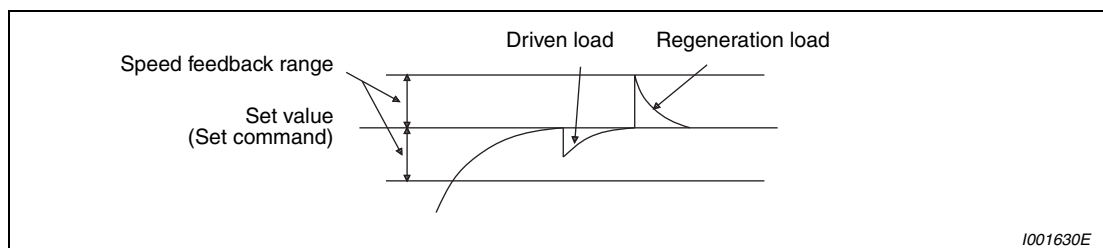

**Fig. 6-262: Setting the range of the speed feedback range**

**Example ▽**

The rated speed of a 4-pole motor is 1740r/min (60Hz)

Calculation of the slip speed:

$$\begin{aligned} \text{Slip } N_{sp} &= \text{Synchronous speed} - \text{Rated speed} \\ &= 1800 - 1740 \text{ (r/min)} \\ &= 60\text{Hz} \end{aligned}$$

Frequency equivalent to slip (fsp):

$$\begin{aligned} \text{fsp} &= (N_{sp} \times \text{Number of poles})/120 \\ &= (60 \times 4)/120 \\ &= 2\text{Hz} \end{aligned}$$



**Feedback gain (Pr. 368)**

Set Pr. 368 "Feedback gain" when the rotation is unstable or response is slow.

If the acceleration/deceleration time is long, feedback response becomes slower. In this case, increase the Pr. 368 setting.

Pr. 368 Setting	Description
Pr. 368 > 1	Although the response becomes faster, overcurrent or unstable rotation is liable to occur.
Pr. 368 < 1	Although the response becomes slower, the motor rotation becomes stable.

**Tab. 6-179:** Setting of parameter 368

**Overspeed detection (Pr. 285)**

If (detection frequency) - (output frequency) > Pr. 285 under encoder feedback control, E.MB1 occurs and the inverter output is stopped to prevent malfunction when the accurate pulse signal from the encoder can not be detected. Overspeed is not detected when Pr. 285 = "9999".

**NOTES**

The encoder should be coupled on the same axis with the motor shaft with a speed ratio of 1 to 1 without any mechanical looseness.

During acceleration/deceleration, encoder feedback control is not performed to prevent unstable phenomenon such as hunting.

Encoder feedback control is performed once output frequency has reached within [set speed] ± [speed feedback range].

If the following conditions occur during encoder feedback control, the inverter operates at the frequency within [set speed] ± [speed feedback range] without coming to an alarm stop nor tracking the motor speed.

- The pulse signals are not received from the encoder due to a signal loss, etc.
- The accurate pulse signal from the encoder can not be detected due to induction noise, etc.
- The motor has been forcibly accelerated (regeneration) or decelerated (motor lock or the like) by large external force.

For the motor with brake, use the RUN signal (inverter running) to open the brake. (The brake may not be opened if the FU (output frequency detection) signal is used.)

Do not turn off the external power supply of the encoder during encoder feedback control. Encoder feedback control functions abnormally.

### 6.24.7 Traverse function (Pr. 592 to Pr. 597)

Traverse operation which varies the amplitude of the frequency in a constant cycle can be performed. This function of the is designed specifically for use in yarn-winding applications in the textile industry.

Pr. No.	Name	Initial Value	Setting Range	Description	Parameters referred to	Refer to Section
<b>592</b>	Traverse function selection	0	0	Traverse function invalid	1 Maximum frequency 2 Minimum frequency 7 Acceleration time 8 Deceleration time 29 Acceleration/ deceleration pattern selection Input terminal function selection	6.8.1 6.8.1 6.11.1 6.11.1 6.11.3 6.14.1
			1	Traverse function is valid only in the external operation mode		
			2	Traverse function is valid independently of operation mode		
<b>593</b>	Maximum amplitude amount	10%	0-25%	Amplitude amount during traverse operation		
<b>594</b>	Amplitude compensation amount during deceleration	10%	0-50%	Compensation amount at the time of amplitude inversion (acceleration → deceleration)		
<b>595</b>	Amplitude compensation amount during acceleration	10%	0-50%	Compensation amount during amplitude inversion operation (deceleration → acceleration)		
<b>596</b>	Amplitude acceleration time	5s	0.1-3600s	Acceleration time during traverse operation		
<b>597</b>	Amplitude deceleration time	5s	0.1-3600s	Deceleration time during traverse operation		

When "1" or "2" is set in Pr. 592 "Traverse function selection", turning on the traverse operation signal (X37) makes the traverse function valid.

Set "37" in any of Pr. 178 to Pr. 189 "Input terminal function selection" and assign the X37 signal to the external terminal. When the X37 signal is not assigned to the input terminal, the traverse function is always valid (X37-ON).

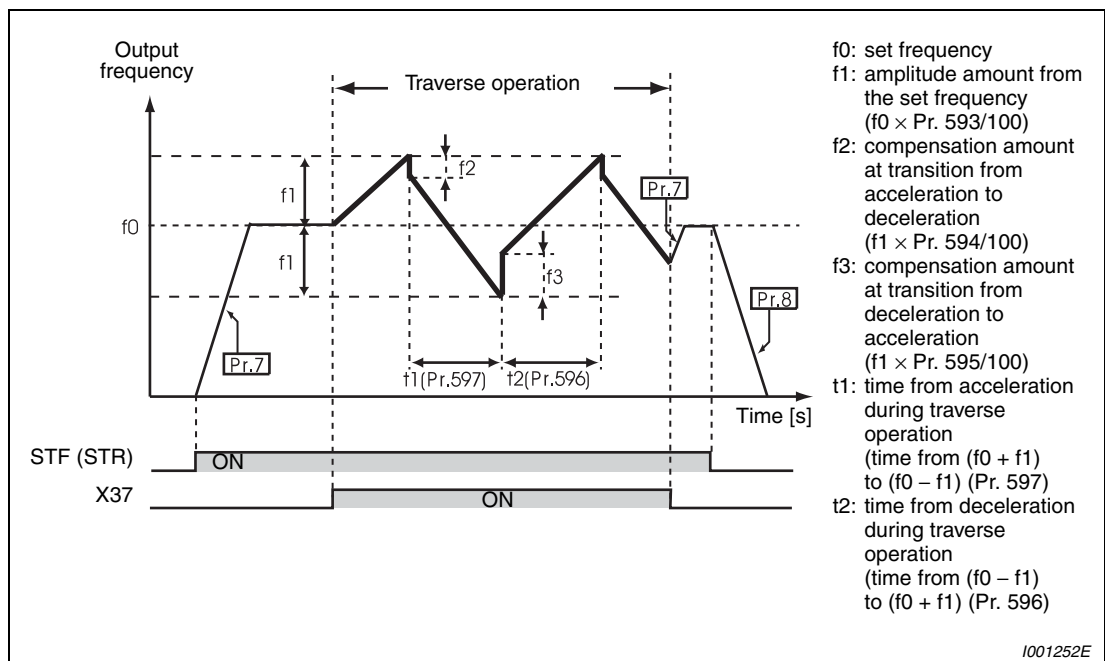

Fig. 6-263: Traverse function

When the starting command (STF or STR) is switched on, the output frequency accelerates to the set frequency  $f_0$  according to the normal Pr. 7 "Acceleration time".

When the output frequency reaches  $f_0$ , traverse operation can be started by switching the X37 signal on, then the frequency accelerates to  $f_0 + f_1$ . (The acceleration time at this time depends on the Pr. 596 setting.)

After having accelerated to  $f_0 + f_1$ , compensation of  $f_2$  ( $f_1 \times \text{Pr. 594}$ ) is made and the frequency decreases to  $f_0 - f_1$ . (The deceleration time at this time depends on the Pr. 597 setting.)

After having decelerated to  $f_0 - f_1$ , compensation of  $f_3$  ( $f_1 \times \text{Pr. 595}$ ) is made and the frequency again accelerates to  $f_0 + f_1$ .

If the X37 signal is turned off during traverse operation, the frequency accelerates/decelerates to  $f_0$  according to the normal acceleration/deceleration time (Pr. 7, Pr. 8). If the start command (STF or STR) is turned off during traverse operation, the frequency decelerates to a stop according to the normal deceleration time (Pr. 8).

**NOTES**

When the second function signal (RT) is on, normal Acceleration/deceleration time (Pr. 7, Pr. 8) is the same as second acceleration/deceleration time (Pr. 44, Pr. 45).

If the set frequency ( $f_0$ ) and traverse operation parameters (Pr. 598 to Pr. 597) are changed, pattern operation is performed at changed  $f_0$  after the output frequency reached  $f_0$  before change.

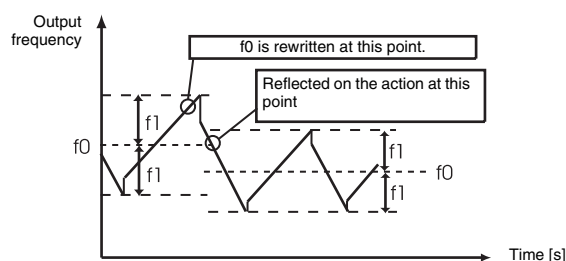

When the output frequency exceeds Pr. 1 "Maximum frequency" or Pr. 2 "Minimum frequency", the output frequency is clamped at maximum/minimum frequency while the set pattern exceeds the maximum/minimum frequency.

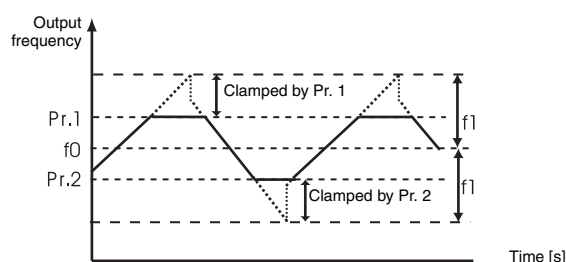

**NOTE**

When the traverse function and S-pattern acceleration/deceleration (Pr. 29 ≠ 0) are selected, S-pattern acceleration/deceleration is performed only in the areas where operation is performed in normal acceleration and deceleration time (Pr. 7, Pr. 8). For acceleration/deceleration during traverse operation, linear acceleration/deceleration is made.

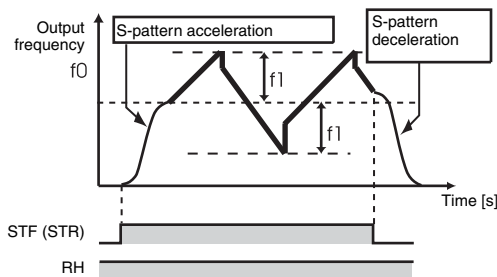

When stall prevention is activated during traverse operation, traverse operation is stopped and normal operation is performed. When stall prevention operation ends, the motor accelerates/decelerates to  $f_0$  in normal acceleration/deceleration time (Pr. 7, Pr. 8). After the output frequency reaches  $f_0$ , traverse operation is again performed.

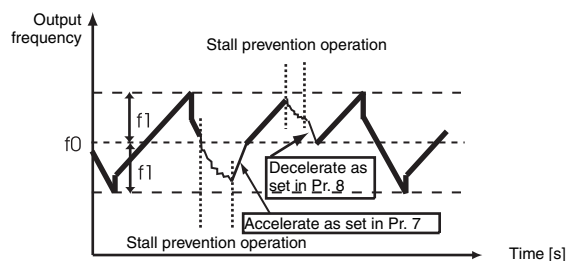

When the value of amplitude inversion compensation amount (Pr. 594, Pr. 595) is too large, pattern operation as set is not performed due to over voltage shut-off and stall prevention.

Changing the terminal assignment using Pr. 178 to Pr. 189 "Input terminal function selection" may affect the other functions. Please make setting after confirming the function of each terminal.

## 6.24.8 Regeneration avoidance function (Pr. 882 to Pr. 886)

This function detects a regeneration status and increases the frequency to avoid the regeneration status.

Possible to avoid regeneration by automatically increasing the frequency and continue operation if the fan happens to rotate faster than the set speed due to the effect of another fan in the same duct.

Pr. No.	Name	Initial Value	Setting Range	Description	Parameters referred to	Refer to Section
<b>882</b>	Regeneration avoidance operation selection	0	0	Regeneration avoidance function invalid	1 Maximum frequency 8 Deceleration time 22 Stall prevention operation level	6.8.1 6.11.1 6.7.4
			1	Regeneration avoidance function valid		
			2	Regeneration avoidance function is valid only during a constant speed operation		
<b>883</b>	Regeneration avoidance operation level	760V 785VDC*	300–800V	Set the bus voltage level at which regeneration avoidance operates. When the bus voltage level is set to low, over voltage error will be less apt to occur. However, the actual deceleration time increases. The set value must be higher than the power supply voltage $\times \sqrt{2}$ . * The initial value differs according to the inverter capacity. (01800 or less/02160 or more)		
<b>884</b>	Regeneration avoidance at deceleration detection sensitivity	0	0	Regeneration avoidance by bus voltage change ratio is invalid		
			1–5	Set sensitivity to detect the bus voltage change 1 (low) → 5 (high)		
<b>885</b>	Regeneration avoidance compensation frequency limit value	6Hz	0–10Hz	Set the limit value of frequency which rises at activation of regeneration avoidance function.		
			9999	Frequency limit invalid		
<b>886</b>	Regeneration avoidance voltage gain	100%	0–200%	Adjust responsiveness at activation of regeneration avoidance. A larger setting will improve responsiveness to the bus voltage change. However, the output frequency could become unstable.		
<b>665</b>	Regeneration avoidance frequency gain	100%	0–200%	When the load inertia of the motor is large, decrease the Pr. 886 setting. When vibration is not suppressed by decreasing the Pr. 886 setting, set a smaller value in Pr. 665.		

### What is regeneration avoidance function? (Pr. 882, Pr. 883)

When the regeneration status is serious, the DC bus voltage rises and an over voltage alarm (E.OV□) may occur. When this bus voltage rise is detected and the bus voltage level reaches or exceeds Pr. 883, increasing the frequency avoids the regeneration status.

The regeneration avoidance function is performed during any of acceleration, constant speed and deceleration.

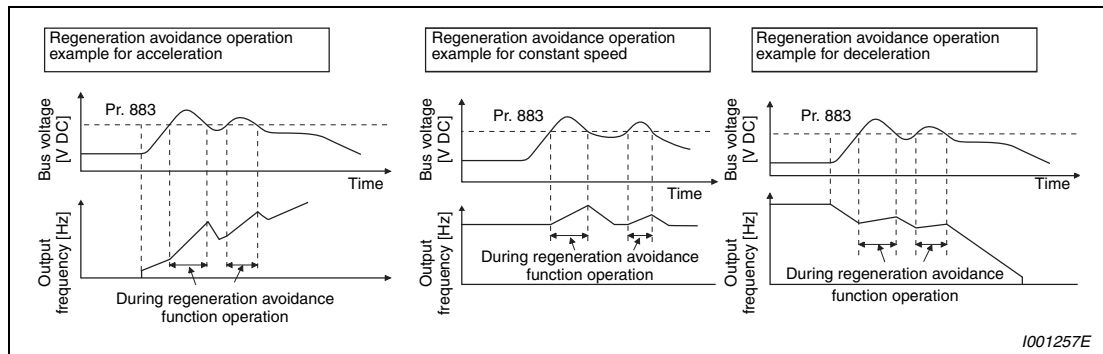

Fig. 6-264: Regeneration avoidance function

#### NOTES

The inclination of the frequency increased or decreased by the regeneration avoidance function changes depending on the regeneration status.

The DC bus voltage of the inverter is normally about  $\sqrt{2}$  times greater than the input voltage (when the input voltage is 440V AC, the bus voltage is about 622V DC). However, it varies with the input power supply waveform.

The Pr. 883 setting should be kept higher than the DC bus voltage level. Otherwise, the regeneration avoidance function is always on.

While overvoltage stall (oL) is activated only during deceleration and stops the decrease in output frequency, the regeneration avoidance function is always on (Pr. 882 = 1) or activated only during a constant speed (Pr. 882 = 2) and increases the frequency according to the regeneration amount.

### To detect the regeneration status during deceleration faster (Pr. 884)

As the regeneration avoidance function cannot respond to an abrupt voltage change by detection of the bus voltage level, the ratio of bus voltage change is detected to stop deceleration if the bus voltage is less than Pr. 883 "Regeneration avoidance operation level". Set that detectable bus voltage change ratio to Pr. 884 as detection sensitivity. Increasing the setting raises the detection sensitivity.

#### NOTE

Too small setting (low detection sensitivity) will disable detection, and too large setting will turn on the regeneration avoidance function if the bus voltage is varied by an input power change, etc.



### Limit regeneration avoidance operation frequency (Pr. 885)

You can limit the output frequency compensated for (increased) by the regeneration avoidance function.

The frequency is limited to the output frequency (frequency prior to regeneration avoidance operation) + Pr. 885 "Regeneration avoidance compensation frequency limit value" during acceleration or constant speed. If the regeneration avoidance frequency exceeds the limit value during deceleration, the limit value is held until the output frequency falls to 1/2 of Pr. 885.

When the regeneration avoidance frequency has reached Pr. 1 "Maximum frequency", it is limited to the maximum frequency.

Pr. 885 is set to "9999", the frequency setting is invalid.

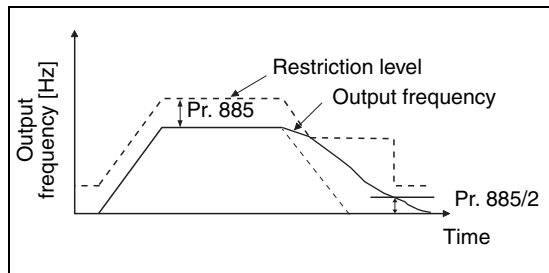

**Fig. 6-265:**  
Limit the output frequency

1001260E

### Regeneration avoidance function adjustment (Pr. 665, Pr. 886)

If the frequency becomes unstable during regeneration avoidance operation, decrease the setting of Pr. 886 "Regeneration avoidance voltage gain". Conversely, if sudden regeneration causes an overvoltage alarm, increase the setting.

When the load inertia of the motor is large, decrease the Pr. 886 setting. When vibration is not suppressed by decreasing the Pr. 886 "Regeneration avoidance voltage gain" setting, set a smaller value in Pr. 665 "Regeneration avoidance frequency gain". When the load inertia of the motor is large, decrease the Pr. 886 setting.

#### NOTES

When regeneration avoidance operation is performed, "oL" (over voltage stall) is displayed and the OL signal is output.

When regeneration avoidance operation is performed, stall prevention is also activated at the same time.

The regeneration avoidance function cannot shorten the actual deceleration time taken to stop the motor. The actual deceleration time depends on the regeneration capability. When shortening the deceleration time, consider using the regeneration unit (FR-BU, MT-BU5, FR-CV, FR-HC, MT-HC).

When using the regeneration unit (FR-BU, MT-BU5, FR-CV, FR-HC, MT-HC), set Pr. 882 to "0" (initial value) (regeneration avoidance function invalid).

When regeneration avoidance operation is performed, the OL signal output item of Pr. 156 also becomes the target of oL (over voltage stall). Pr. 157 "OL signal output timer" also becomes the target of (over voltage stall).

Under vector control, unusual noise may be generated from the motor during deceleration when using regeneration avoidance function. To prevent this, make gain adjustment, e.g. by performing easy gain tuning. (Refer to section 6.3.3)

## 6.25 Useful functions

Purpose	Parameters that must be set		Refer to Section
Increase cooling fan life	Cooling fan operation selection	Pr. 244	6.25.1
To determine the maintenance time of parts.	Inverter part life display	Pr. 255–Pr. 259	6.25.2
	Maintenance output function	Pr. 503–Pr. 504	6.25.3
	Current average value monitor signal	Pr. 555–Pr. 557	6.25.4
Freely available parameter	Free parameter	Pr. 888–Pr. 889	6.25.5

### 6.25.1 Cooling fan operation selection (Pr. 244)

You can control the operation of the cooling fan (00083 or more) built in the inverter.

Pr. No.	Name	Initial Value	Setting Range	Description	Parameters referred to	Refer to Section
244	Cooling fan operation selection	1	0	Operates at power on Cooling fan on/off control invalid (The cooling fan is always on at power on)	190–196 Output terminal function selection	6.14.5
			1	Cooling fan on/off control valid The fan is always on while the inverter is running. During a stop, the inverter status is monitored and the fan switches on-off according to the temperature of the heatsink.		

In either of the following cases, fan operation is regarded as faulty, "FN" is shown on the operation panel, and the fan fault "FAN" and minor fault "LF" signals are output.

- Pr. 244 = 0  
When the fan comes to a stop with power on.
- Pr. 244 = 1  
When the fan stops during the fan ON command while the inverter is running.

For the terminal used for FAN signal output, set "25" (source logic) or "125" (sink logic) to any of Pr. 190 to Pr.196 "Output terminal function selection", and for the LF signal, set "98" (source logic) or "198" (sink logic).

#### NOTE

When terminal assignment is changed using Pr. 190 to Pr. 196 "Output terminal function selection", the other functions may be affected. Please make setting after confirming the function of each terminal.

### 6.25.2 Display of the life of the inverter parts (Pr. 255 to Pr. 259)

Degrees of deterioration of main circuit capacitor, control circuit capacitor or inrush current limit circuit and cooling fan can be diagnosed by monitor.

When any part has approached the end of its life, an alarm can be output by self diagnosis to prevent a fault. (Use the life check of this function as a guideline since the life except the main circuit capacitor is calculated theoretically.) For the life check of the main circuit capacitor, the alarm signal (Y90) will not be output if a measuring method shown on page 6-533 is not performed.

Pr. No.	Name	Initial Value	Setting Range	Description	Parameters referred to	Refer to Section
<b>255</b>	Life alarm status display	0	(0-15)	Display whether the control circuit capacitor, main circuit capacitor, cooling fan, and each parts of the inrush current limit circuit has reached the life alarm output level or not. Reading only	190-196 Output terminal function selection	6.14.5
<b>256</b>	Inrush current limit circuit life display	100%	(0-100%)	Display the deterioration degree of the inrush current limit circuit. Reading only		
<b>257</b>	Control circuit capacitor life display	100%	(0-100%)	Display the deterioration degree of the control circuit capacitor. Reading only		
<b>258</b>	Main circuit capacitor life display	100%	(0-100%)	Display the deterioration degree of the main circuit capacitor. Reading only The value measured by Pr. 259 is displayed.		
<b>259</b>	Main circuit capacitor life measuring	0	0/1 (2/3/8/9)	Setting "1" and switching the power supply off starts the measurement of the main circuit capacitor life (refer to the following pages). When the Pr. 259 value is "3" after powering on again, the measuring is completed. Read the deterioration degree in Pr. 258.		

#### Life alarm display and signal output (Y90 signal, Pr. 255)

Whether any of the control circuit capacitor, main circuit capacitor, cooling fan and inrush current limit circuit has reached the life alarm output level or not can be checked by Pr. 255 "Life alarm status display" and life alarm signal (Y90).

- ① Read the setting of parameter 255.

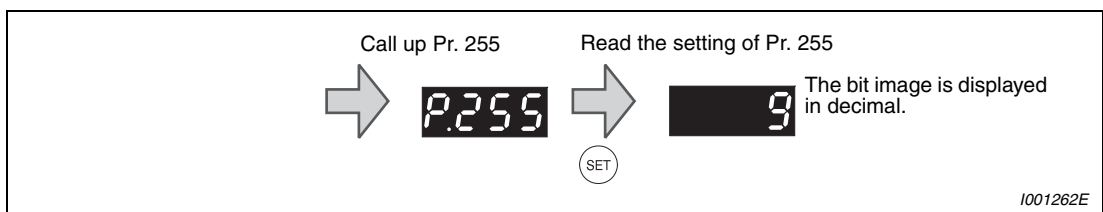

Fig. 6-266: Read parameter 255

- ② When the life alarm output level is reached, the bits are set as follows.

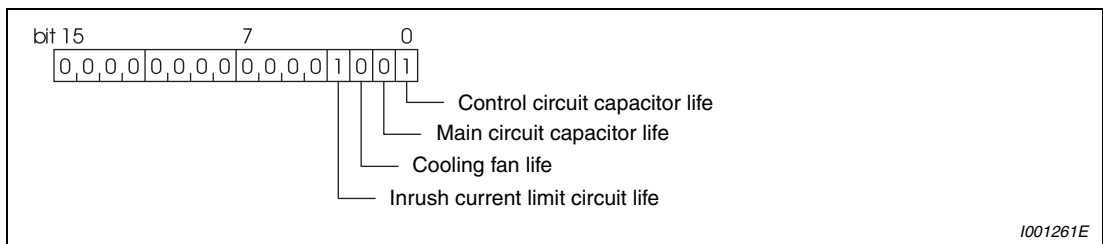

Fig. 6-267: Bits of parameter 255

Pr. 255 (decimal)	Bits (binary)	Inrush Current Limit Circuit Life	Cooling Fan Life	Main Circuit Capacitor Life	Control Circuit Capacitor Life
15	1111	✓	✓	✓	✓
14	1110	✓	✓	✓	—
13	1101	✓	✓	—	✓
12	1100	✓	✓	—	—
11	1011	✓	—	✓	✓
10	1010	✓	—	✓	—
9	1001	✓	—	—	✓
8	1000	✓	—	—	—
7	0111	—	✓	✓	✓
6	0110	—	✓	✓	—
5	0101	—	✓	—	✓
4	0100	—	✓	—	—
3	0011	—	—	✓	✓
2	0010	—	—	✓	—
1	0001	—	—	—	✓
0	0000	—	—	—	—

**Tab. 6-180:** Displaying the end of service life by bits

- ✓: End of the service life is reached  
 —: End of the service life is not reached

The life alarm signal (Y90) turns on when any of the control board capacitor, main circuit capacitor, cooling fan and inrush current limit circuit reaches the life alarm output level.

For the terminal used for the Y90 signal, set "90" (source logic) or "190" (sink logic) to any of Pr. 190 to Pr.196 "Output terminal function selection".

#### NOTES

The digital output option (FR-A7AY) allows the control circuit capacitor life signal (Y86), main circuit capacitor life signal (Y87), cooling fan life signal (Y88) and inrush current limit circuit life signal (Y89) to be output individually.

When terminal assignment is changed using Pr. 190 to Pr. 196 "Output terminal function selection", the other functions may be affected. Please make setting after confirming the function of each terminal.

#### Life display of the inrush current limit circuit (Pr. 256)

The life of the inrush current limit circuit (relay, contactor and inrush resistor) is displayed in Pr. 259.

The number of contact (relay, contactor, thyristor) ON times is counted, and it is counted down from 100% (1 million times) every 1%/10,000 times. As soon as 10% (900,000 times) is reached, Pr. 255 bit 3 is turned on and also an alarm is output to the Y90 signal.

#### Control circuit capacitor life display (Pr. 257)

The deterioration degree of the control circuit capacitor is displayed in Pr. 257 as a life.

In the operating status, the control circuit capacitor life is calculated from the energizing time and temperature of the inverter's heatsink, and is counted down from 100%. As soon as the control circuit capacitor life falls below 10%, Pr. 255 bit 0 is turned on and also an alarm is output to the Y90 signal.

**Main circuit capacitor life display (Pr. 258, Pr. 259)**

The deterioration degree of the main circuit capacitor is displayed in Pr. 258 as a life.

On the assumption that the main circuit capacitor capacitance at factory shipment is 100%, the capacitor life is displayed in Pr. 258 every time measurement is made. When the measured value falls to or below 85%, Pr. 255 bit 1 is turned on and also an alarm is output to the Y90 signal.

Measure the capacitor capacity according to the following procedure and check the deterioration level of the capacitor capacity.

- ① Check that the motor is connected and at a stop. Please also provide a separate mains power supply for the inverter's control circuit (terminals L11 and L21).
- ② Set "1" (measuring start) in Pr. 259.
- ③ Switch power off. The inverter applies DC voltage to the motor to measure the capacitor capacity while the inverter is off.
- ④ After making sure that the power lamp is off, switch on the power supply again.
- ⑤ Check that "3" (measuring completion) is set in Pr. 259, read Pr 258, and check the deterioration degree of the main circuit capacitor.

Pr. 259	Description	Remarks
0	No measurement	Initial value
1	Measurement start	Measurement starts when the power supply is switched off.
2	During measurement	Only displayed and cannot be set
3	Measurement complete	
8	Forced end (see ③, ⑦, ⑧, ⑨ below)	
9	Measurement error (see ④, ⑤, ⑥ below)	

**Tab. 6-181: Parameter 259**

The life of the main circuit capacitor can not be measured in the following conditions:

- ① The FR-HC, MT-HC, FR-CV, FR-BU, MT-BU5 or BU is connected.
- ② Terminals R1/L11, S1/L21 or DC power supply is connected to the terminal P/+ and N/-.
- ③ Switch power on again during measuring.
- ④ The motor is not connected to the inverter.
- ⑤ The motor is running. (The motor is coasting.)
- ⑥ The motor capacity is two ranks (or more) smaller as compared to the inverter capacity.
- ⑦ The inverter is at an alarm stop or an alarm occurred while power is off.
- ⑧ The inverter output is shut off with the MRS signal.
- ⑨ The start command is given while measuring.

Operating environment: Ambient Temperature (annual average 40°C (free from corrosive gas, flammable gas, oil mist, dust and dirt))  
Output current (80% of the rated current of Mitsubishi standard 4P motor)

**Cooling fan life display**

The cooling fan speed of 50% or less is detected and "FN" is displayed on the operation panel (FR-DU07) and parameter unit (FR-PU04/FR-PU07). As an alarm display, Pr. 255 bit 2 is turned on and also an alarm is output to the Y90 signal.

**NOTE**

When the inverter is mounted with two or more cooling fans, the life of even one cooling fan is diagnosed.

### 6.25.3 Maintenance timer alarm (Pr. 503, Pr. 504)

When the cumulative energizing time of the inverter reaches the parameter set time, the maintenance timer output signal (Y95) is output. "MT" is displayed on the operation panel (FR-DU07). This can be used as a guideline for the maintenance time of peripheral devices.

Pr. No.	Name	Initial Value	Setting Range	Description	Parameters referred to	Refer to Section
<b>503</b>	Maintenance timer	0	0 (1-9998)	Display the cumulative energizing time of the inverter in 100h increments. Reading only Writing the setting of "0" clears the cumulative energizing time.	190-196 Output terminal function selection	6.14.5
<b>504</b>	Maintenance timer alarm output set time	9999	0-9998	Set the time taken until when the maintenance timer alarm output signal (Y95) is output.		
			9999	No function		

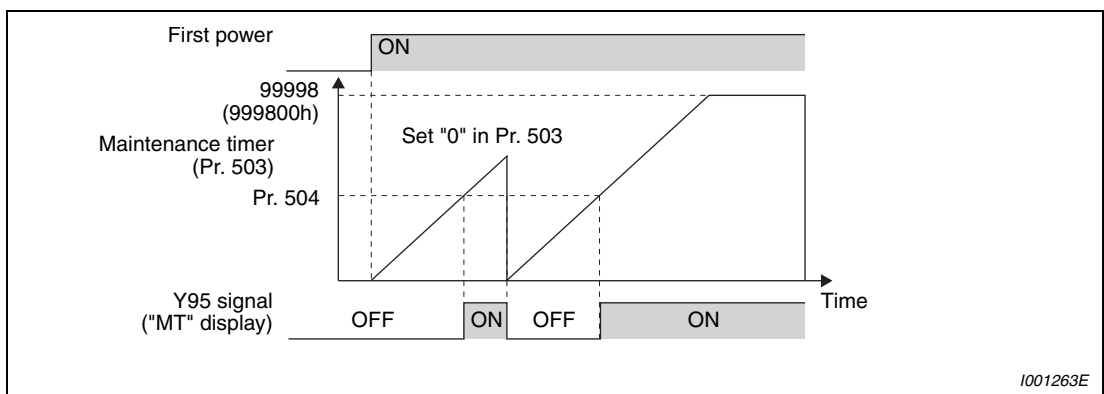

**Fig. 6-268: Maintenance timer**

The cumulative energizing time of the inverter is stored into the EEPROM every hour and indicated in Pr. 503 "Maintenance timer" in 100h increments. Pr. 503 is clamped at 9998 (999800h).

When the Pr. 503 value reaches the time set to Pr. 504 "Maintenance timer alarm output set time" (100h increments), the maintenance timer alarm output signal (Y95) is output.

For the terminal used for the Y95 signal output, assign the function by setting "95" (source logic) or "195" (sink logic) to any of Pr. 190 to Pr. 196 "Output terminal function selection".

**NOTES**

- | The cumulative energizing time is counted every hour. The energizing time of less than 1h is not counted.
- | When terminal assignment is changed using Pr. 190 to Pr. 196 "Output terminal function selection", the other functions may be affected. Please make setting after confirming the function of each terminal.

### 6.25.4 Current average value monitor signal (Pr. 555 to Pr. 557)

The average value of the output current during constant speed operation and the maintenance timer value are output as a pulse to the current average value monitor signal (Y93). The pulse width output to the I/O module of the PLC or the like can be used as a guideline due to abrasion of machines and elongation of belt and for aged deterioration of devices to know the maintenance time.

The current average value monitor signal (Y93) is output as pulse for 20s as 1 cycle and repeatedly output during constant speed operation.

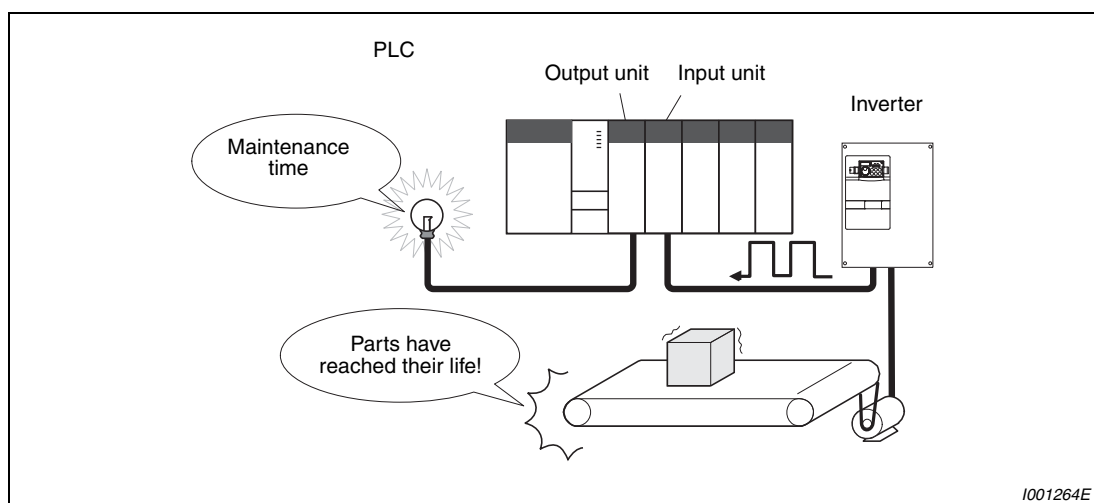

**Fig. 6-269:** Monitoring the maintenance timer and current average value

Pr. No.	Name	Initial Value	Setting Range	Description	
<b>555</b>	Current average time	1s	0.1–1.0s	Set the time taken to average the current during start bit output (1s).	
<b>556</b>	Data output mask time	0s	0.0–20.0s	Set the time for not obtaining (mask) transient state data.	
<b>557</b>	Current average value monitor signal output reference current	Rated inverter current	01800 or less	0–500A	Set the reference (100%) for outputting the signal of the current average value.
			02160 or more	0–3600A	

Parameters referred to	Refer to Section
190–196 Output terminal function selection	6.14.5
503 Maintenance timer	6.25.3
57 Restart coasting time	6.16.1

The above parameters allow its setting to be changed during operation in any operation mode even if "0" (initial value) is set in Pr. 77 "Parameter write selection".



The pulse output of the current average value monitor signal (Y93) is shown below.

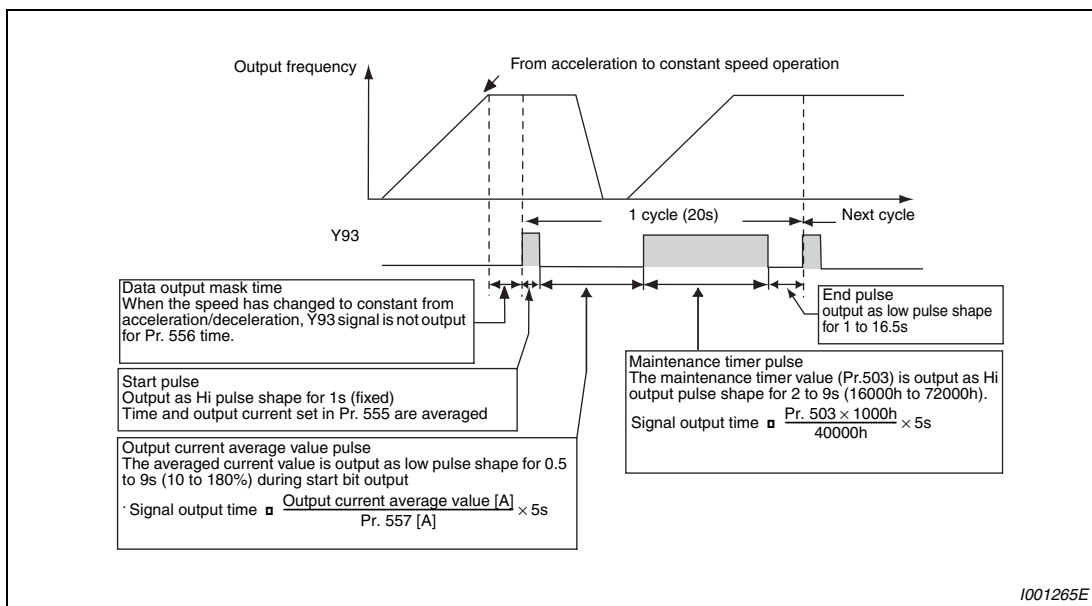

**Fig. 6-270: Output of the pulse signal Y93**

For the terminal used for the Y93 signal output, assign the function by setting "93" (source logic) or "193" (sink logic) to any of Pr. 190 to Pr. 194 "Output terminal function selection". (The function can not be assigned to Pr. 195 "ABC1 terminal function selection" and Pr. 196 "ABC2 terminal function selection".)

**Setting of Pr. 556 "Data output mask time"**

The output current is unstable (transient state) right after the operation is changed from the acceleration/deceleration state to the constant speed operation. Set the time for not obtaining (mask) transient state data in Pr.556.

**Setting of the Pr. 555 "Current average time"**

The average output current is calculated during Hi output of start bit (1s). Set the time taken to average the current during start bit output in Pr. 555.

**Setting of Pr. 557 "Current average value monitor signal output reference current"**

Set the reference (100%) for outputting the signal of the current average value. Obtain the time of the low pulse after a fixed start pulse of 1s from the following calculation.

$$\frac{\text{Output current average value}}{\text{Pr. 557}} \times 5\text{s (output current average value 100 \% / 5s)}$$

Note that the output time range is 0.5 to 9s, and it is 0.5s when the output current average value is less than 10% of the setting value of Pr. 557 and 9s when it exceeds 180%.

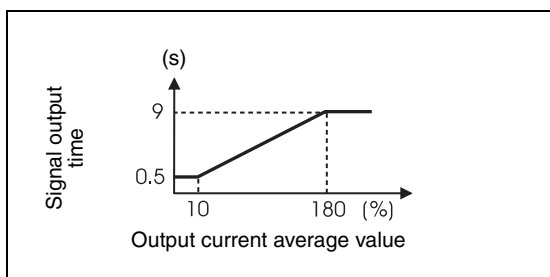

**Fig. 6-271:**  
Signal output time for the current average value

1001266E

**Example ▽**

When Pr. 557 = 10A and the average value of output current is 15A, the current average value monitor signal is output as low pulse shape for 7.5s.

$$\text{Signal output time} = \frac{15\text{A}}{10\text{A}} \times 5\text{s} = 7.5\text{s}$$

△

**Output of Pr. 503 "Maintenance timer"**

After the output current average value is output as low pulse shape, the maintenance timer value is output as high pulse shape. The output time of the maintenance timer value is obtained from the following calculation.

$$\frac{\text{Pr. 503}}{40000\text{h}} \times 5\text{s (Maintenance timer value 100\% / 5s)}$$

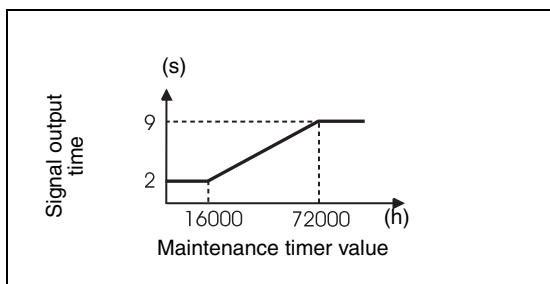

**Fig. 6-272:**  
Signal output time for the maintenance output value

1001267E

Note that the output time range is 2 to 9s, and it is 2s when Pr. 503 is less than 16000h and 9s when it exceeds 72000h.

## NOTES

Mask of data output and sampling of output current are not performed during acceleration/deceleration.

When the speed is changed to acceleration/deceleration from constant speed during start bit output, the data is judged as invalid, the start bit is output as high pulse shape for 3.5s, and the end signal is output as low pulse shape for 16.5s. The signal is output for at least 1 cycle even when acceleration/deceleration state continues after the start bit output is completed.

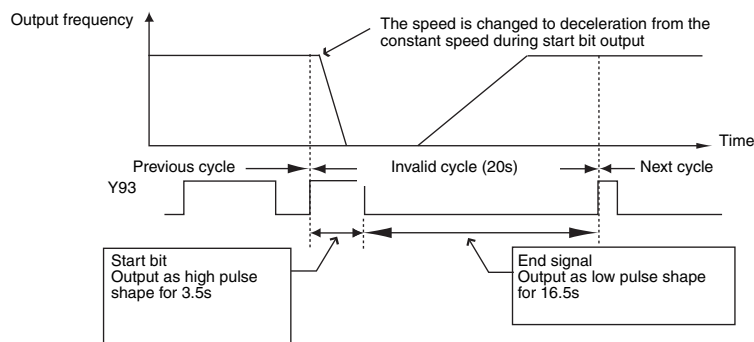

When the output current value (inverter output current monitor) is 0A on completion of the 1 cycle signal output, the signal is not output until the speed becomes constant next time.

The current average value monitor signal (Y93) is output as low pulse shape for 20s (without data output) under the following condition:

- When the motor is in the acceleration/deceleration state on completion of the 1 cycle signal output.
- When 1-cycle signal output was ended during restart operation with the setting of automatic restart after instantaneous power failure (Pr. 57 ≠ 9999).
- When automatic restart operation was being performed with automatic restart after instantaneous power failure selected (Pr.57 ≠ 9999) on completion of the data output mask.

When terminal assignment is changed using Pr. 190 to Pr. 196 "Output terminal function selection", the other functions may be affected. Please make setting after confirming the function of each terminal.

### 6.25.5 Free parameters (Pr. 888, Pr. 889)

Parameters you can use for your own purposes. You can input any number within the setting range "0" to "9999".

For example, the number can be used:

- As a unit number when multiple units are used.
- As a pattern number for each operation application when multiple units are used.
- As the year and month of introduction or inspection.

Pr. No.	Name	Initial Value	Setting Range	Description	Parameters referred to	Refer to Section
<b>888</b>	Free parameter 1	9999	0-9999		—	
<b>889</b>	Free parameter 2	9999	0-9999			

The above parameters allow its setting to be changed during operation in any operation mode even if "0" (initial value) is set in Pr. 77 "Parameter write selection".

#### NOTES

The set value is stored in EEPROM as same as other parameter, the setting value is saved even after power off.

Pr. 888 and Pr. 889 do not influence the inverter operation.

## 6.26 Setting for the parameter unit, operation panel

Purpose	Parameters that must be set		Refer to Section
Switch the display language of the parameter unit	PU display language selection	Pr. 145	6.26.1
Use the setting dial of the operation panel like a volume for frequency setting. Key lock of operation panel	Operation panel operation selection	Pr. 161	6.26.2
Control of the parameter unit, operation panel buzzer	PU buzzer control	Pr. 990	6.26.3
Adjust the LCD contrast of the parameter unit	PU contrast adjustment	Pr. 991	6.26.4

### 6.26.1 PU display language selection (Pr. 145)

By using parameter 145 you can select the display language for the parameter unit FR-PU04 or FR-PU07.

Pr. No.	Name	Initial Value	Setting Value	Description
<b>145</b>	PU display language selection	1	0	Japanese
			1	English
			2	German
			3	French
			4	Spanish
			5	Italian
			6	Swedish
			7	Finnish

Parameters referred to	Refer to Section
—	

## 6.26.2 Operation panel frequency setting/key lock operation selection (Pr. 161)

The setting dial of the operation panel (FR-DU07) can be used like a potentiometer to perform operation.

The key operation of the operation panel can be disabled.

Pr. No.	Name	Initial Value	Setting Range	Description	Parameters referred to	Refer to Section
<b>161</b>	Frequency setting/key lock operation selection	0	0	Setting dial frequency setting mode Key lock mode invalid	—	
			1	Setting dial volume mode		
			10	Setting dial frequency setting mode Key lock mode valid These setting must be confirmed by pressing the MODE key for about 2 s.		
			11	Setting dial volume mode		

### NOTES

You can find a detailed description of the operation panel with examples in section 4.3 "Operation Panel FR-DU07".

When the setting dial and key operation is made invalid, "HOLD" appears on the operation panel while pressing a key.

The STOP/RESET key is valid even in the operation lock status.

## 6.26.3 Buzzer control (Pr. 990)

You can make the buzzer "beep" when you press a key of the operation panel (FR-DU07) and parameter unit (FR-PU04/FRPU07).

Pr. No.	Name	Initial Value	Setting Range	Description	Parameters referred to	Refer to Section
<b>990</b>	PU buzzer control	1	0	Without buzzer	—	
			1	With buzzer		

The above parameter allows its setting to be changed during operation in any operation mode even if "0" (initial value) is set in Pr. 77 "Parameter write selection".

## 6.26.4 PU contrast adjustment (Pr. 991)

Contrast adjustment of the LCD of the parameter unit (FR-PU04 or FR-PU07) can be performed. Decreasing the setting value makes contrast light. You should press the WRITE key to store the PU contrast setting.

Pr. No.	Name	Initial Value	Setting Range	Description	Parameters referred to	Refer to Section
<b>991</b>	PU contrast adjustment	58	0–63	0: Light ↓ 63: Dark	—	

The above parameters are displayed as simple mode parameters only when a parameter unit FR-PU04 or FR-PU07 is connected.

# 7 Troubleshooting

When an alarm occurs in the inverter, the protective function is activated bringing the inverter to an alarm stop and the PU display automatically changes to any of the following error (alarm) indications. If your fault does not correspond to any of the following errors or if you have any other problem, please contact your sales representative.

- Retention of alarm output signal. . . . . When the magnetic contactor (MC) provided on the input side of the inverter is opened at the activation of the protective function, the inverter's control power will be lost and the alarm output will not be held.
- Alarm display . . . . . When the protective function is activated, the operation panel display automatically switches to the above indication.
- Resetting method . . . . . When a protective function of the inverter is activated, the power output of the inverter is blocked (motor is coasting). The inverter cannot start up again unless an automatic restart has been configured or the inverter is reset. Please observe carefully the warnings contained below in the configuration of an automatic restart or the execution of a reset.
- If protective functions were activated (i. e. the inverter switched off with an error message) follow the instructions for error correction provided in the manual for the inverter. Especially in the case of short circuits or earth contacts in the inverter output and mains over voltages the cause of the fault must be determined prior to switching on again as a recurrence of such faults at short intervals can lead to premature aging of components or even the complete breakdown of the device. After the cause of the fault has been found and corrected the inverter can be reset and operations continue.

## 7.1 List of alarm display

Operation Panel Indication			Name	Refer to Page
Error message	<i>HOLD</i>	HOLD	Operation panel lock	7-5
	<i>Er 1</i> to <i>Er 4</i>	Er1 to Er4	Parameter write error	7-5
	<i>rE 1</i> to <i>rE 4</i>	rE1 to rE4	Copy operation error	7-6
	<i>Err.</i>	Err.	Error	7-7
Warnings	<i>OL</i>	OL	Stall Prevention (over current)	7-8
	<i>oL</i>	oL	Stall prevention (over voltage)	7-8
	<i>rb</i>	RB	Regenerative brake prealarm	7-9
	<i>TH</i>	TH	Electronic thermal relay function prealarm	7-9
	<i>PS</i>	PS	PU Stop	7-9
	<i>MT</i>	MT	Maintenance signal output	7-9
	<i>CP</i>	CP	Parameter copy	7-10
	<i>SL</i>	SL	Speed limit indication (Output during speed limit)	7-10
Minor fault	<i>Fn</i>	FN	Fan fault	7-10
Major failures	<i>E.O.C 1</i>	E.O.C1	Over current shut-off during acceleration	7-11
	<i>E.O.C 2</i>	E.O.C2	Over current cut-off during constant speed	7-11
	<i>E.O.C 3</i>	E.O.C3	Over current shutoff during deceleration or stop	7-12
	<i>E.O.V 1</i>	E.O.V1	Regenerative over voltage cut-off during acceleration	7-12
	<i>E.O.V 2</i>	E.O.V2	Regenerative over voltage cut-off during constant speed	7-12
	<i>E.O.V 3</i>	E.O.V3	Regenerative over voltage shut-off during deceleration or stop	7-12
	<i>E.T.H F</i>	E.THT	Inverter overload shutoff (electronic thermal relay function)	7-13
	<i>E.T.H M</i>	E.THM	Motor overload shutoff (electronic thermal relay function)	7-13
	<i>E.FI n</i>	E.FIN	Fin overheat	7-13
	<i>E.I PF</i>	E.IPF	Instantaneous power failure protection	7-14
	<i>E. bE</i>	E.BE	Brake transistor alarm detection/internal circuit error	7-14
	<i>E.U.V T</i>	E.UVT	Under voltage protection	7-14

**Tab. 7-1:** List of alarm display (1)



Operation Panel Indication		Name	Refer to Page	
Major failures	E.I.LF	E.ILF <sup>①</sup>	Input phase failure	7-15
	E.O.LT	E.OLT	Stall prevention	7-15
	E.GF	E.GF	Output side earth (ground) fault over current protection	7-15
	E.LF	E.LF	Output phase failure protection	7-15
	E.O.HT	E.OHT	External thermal relay operation	7-16
	E.P.TC	E.PTC <sup>①</sup>	PTC thermistor operation	7-16
	E.O.PT	E.OPT	Error related to the connection of a (external) option	7-16
	E.O.P3	E.OP3	Error of the internal (extension slot) installed option (e.g. communication error)	7-17
	E. 1 to E. 3	E. 1	Error of the internal (extension slot) installed option (e.g. connection or contact fault respectively)	7-17
	E. PE	E.PE	Parameter storage device alarm	7-17
	E.PE2	E.PE2 <sup>①</sup>	Parameter storage device alarm	7-18
	E.PUE	E.PUE	PU disconnection	7-18
	E.r.ET	E.RET	Retry count excess	7-18
	E. 6 E. 7 E.CPU	E. 6 E. 7 E.CPU	CPU error	7-18
	E.CTE	E.CTE	Operation panel power supply short circuit RS-485 terminal power supply short circuit	7-19
	E.MB1 to E.MB7	E.MB1 to E.MB7	Brake sequence error	7-19
	E.OS	E.OS	Overspeed occurrence	7-19
	E.OSd	E.OSD	Speed deviation excess detection	7-19
	E.ECT	E.ECT	Signal loss detection	7-20
	E. Od	E.OD	Excessive position error	7-20
	E.EP	E.EP	Encoder phase error	7-20
	E.P24	E.P24	24V DC power output short circuit	7-20
	E.CdO	E.CDO <sup>①</sup>	Output current detection value exceeded	7-21

**Tab. 7-1:** List of alarm display (2)

<sup>①</sup> If one of the errors "E.ILF, E.PTC, E.PE2, E.CDO" occurs when using the operation unit FR-PU04, "Fault 14" will be displayed.

Operation Panel Indication			Name	Refer to Page
Major failures	E1 0H	E.IOH ①	Inrush resistor overheat	7-21
	E.SEr	E.SER ①	Communication error (inverter)	7-21
	E.A1 E	E.AIE ①	Analog input error	7-21
	E.USB	E.USB ①	USB communication error	7-22
	E. 11	E.11	Opposite rotation deceleration error	7-22
	E. 13	E.13 ①	Internal circuit error	7-22

**Tab. 7-1:** List of alarm display (3)

① If one of the errors "E.ILF, E.PTC, E.PE2, E.CDO" occurs when using the operation unit FR-PU04, "Fault 14" will be displayed.

## 7.2 Causes and corrective actions

### Error Message

A message regarding operational troubles is displayed. Output is not shutoff.

<b>Operation Panel Indication</b>	<b>HOLD</b>	<b>HOLD</b>
<b>Name</b>	Operation panel lock	
<b>Description</b>	Operation lock mode is set. Operation other than STOP/RESET is made invalid. (Refer to section 4.3.3.)	
<b>Check point</b>	—	
<b>Corrective action</b>	Press the MODE key for 2s to release lock.	

<b>Operation Panel Indication</b>	<b>Er1</b>	<b>Er1</b>
<b>Name</b>	Write disable error	
<b>Description</b>	<ol style="list-style-type: none"> <li>1) You attempted to make parameter setting when Pr. 77 Parameter write selection has been set to disable parameter write.</li> <li>2) Frequency jump setting range overlapped.</li> <li>3) Adjustable 5 points V/F settings overlapped</li> <li>4) The PU and inverter cannot make normal communication.</li> </ol>	
<b>Check point</b>	<ol style="list-style-type: none"> <li>1) Check the setting of Pr. 77 "Parameter write selection" (Refer to section 6.21.2.)</li> <li>2) Check the settings of Pr. 31 to 36 (frequency jump). (Refer to section 6.8.2.)</li> <li>3) Check the settings of Pr. 100 to Pr. 109 (Adjustable 5 points V/F). (Refer to section 6.9.4.)</li> <li>4) Check the connection of the PU and inverter.</li> </ol>	

<b>Operation Panel Indication</b>	<b>Er2</b>	<b>Er2</b>
<b>Name</b>	Write error during operation	
<b>Description</b>	When parameter write was performed during operation with a value other than "2" (writing is enabled independently of operation status in any operation mode) is set in Pr. 77 and the STF (STR) is on.	
<b>Check point</b>	<ol style="list-style-type: none"> <li>1) Check the Pr. 77 setting. (Refer to section 6.21.2.)</li> <li>2) Check that the inverter is not operating.</li> </ol>	
<b>Corrective action</b>	<ol style="list-style-type: none"> <li>1) Set "2" in Pr. 77.</li> <li>2) After stopping operation, make parameter setting.</li> </ol>	

<b>Operation Panel Indication</b>	<b>Er3</b>	<b>Er3</b>
<b>Name</b>	Calibration error	
<b>Description</b>	Analog input bias and gain calibration values are too close.	
<b>Corrective action</b>	Check the settings of C3, C4, C6 and C7 (calibration functions). (Refer to section 6.20.5.)	

<b>Operation Panel Indication</b>	Er4	Er4
<b>Name</b>	Mode designation error	
<b>Description</b>	You attempted to make parameter setting in the NET operation mode when Pr. 77 is not "2".	
<b>Check point</b>	1) Check that operation mode is "PU operation mode". 2) Check the Pr. 77 setting. (Refer to section 6.21.2.)	
<b>Corrective action</b>	1) After setting the operation mode to the "PU operation mode", make parameter setting. (Refer to section 6.21.2.) 2) After setting "2" in Pr. 72, make parameter setting.	

<b>Operation Panel Indication</b>	rE1	rE1
<b>Name</b>	Parameter read error	
<b>Description</b>	An error occurred in the E <sup>2</sup> PROM on the operation panel side during parameter copy reading.	
<b>Check point</b>	—	
<b>Corrective action</b>	<ul style="list-style-type: none"> <li>• Make parameter copy again. (Refer to section 4.3.10).</li> <li>• Check for an operation panel (FR-DU07) failure. Please contact your sales representative.</li> </ul>	

<b>Operation Panel Indication</b>	rE2	rE2
<b>Name</b>	Parameter write error	
<b>Description</b>	1) You attempted to perform parameter copy write during operation. 2) An error occurred in the E <sup>2</sup> PROM on the operation panel side during parameter copy writing.	
<b>Check point</b>	Is the FWD or REV LED of the operation panel (FR-DU07) lit or flickering?	
<b>Corrective action</b>	1) After stopping operation, make parameter copy again. (Refer to section 4.3.10.) 2) Check for an operation panel (FR-DU07) failure. Please contact your sales representative.	

<b>Operation Panel Indication</b>	rE3	rE3
<b>Name</b>	Parameter verification error	
<b>Description</b>	1) Data on the operation panel side and inverter side are different. 2) An error occurred in the E <sup>2</sup> PROM on the operation panel side during parameter verification.	
<b>Check point</b>	Check for the parameter setting of the source inverter and inverter to be verified.	
<b>Corrective action</b>	1) Press the SET key to continue verification. Make parameter verification again. (Refer to section 4.3.10). 2) Check for an operation panel (FR-DU07) failure. Please contact your sales representative.	

<b>Operation Panel Indication</b>	rE4	rE4
<b>Name</b>	Model error	
<b>Description</b>	1) A different model was used for parameter write and verification during parameter copy. 2) When parameter copy write is stopped after parameter copy read is stopped.	
<b>Check point</b>	1) Check that the verified inverter is the same model. 2) Check that the power is not turned off or an operation panel is not disconnected, etc. during parameter copy read.	
<b>Corrective action</b>	1) Use the same model (FR-A700 series) for parameter copy and verification. 2) Perform parameter copy read again.	

<b>Operation Panel Indication</b>	Err.	Err.
<b>Description</b>	1) The RES signal is on. 2) The PU and inverter cannot make normal communication (contact fault of the connector). 3) When the control circuit power (R1/L11, S1/L21) and the main circuit power are connected to a separate power, it may appear at turning on of the main circuit. It is not a fault.	
<b>Corrective action</b>	1) Turn off the RES signal. 2) Check the connection of the PU and inverter.	

**Warnings**

When the protective function is activated, the output is not shut off.

<b>Operation Panel Indication</b>	OL		FR-PU04 FR-PU07	OL
<b>Name</b>	Stall prevention (overcurrent)			
<b>Description</b>	During acceleration	When the output current (output torque during real sensorless vector control or vector control) of the inverter exceeds the stall prevention operation level (Pr. 22 "Stall prevention operation level", etc.), this function stops the increase in frequency until the overload current decreases to prevent the inverter from resulting in overcurrent shut-off. When the overload current has decreased below stall prevention operation level, this function increases the frequency again.		
	During constant-speed operation	When the output current (output torque during real sensorless vector control or vector control) of the inverter exceeds the stall prevention operation level (Pr. 22 "Stall prevention operation level", etc.), this function reduces frequency until the overload current decreases to prevent the inverter from resulting in overcurrent shut-off. When the overload current has decreased below stall prevention operation level, this function increases the frequency up to the set value.		
	During deceleration	When the output current (output torque during real sensorless vector control or vector control) of the inverter exceeds the stall prevention operation level (Pr. 22 "Stall prevention operation level", etc.), this function stops the decrease in frequency until the overload current decreases to prevent the inverter from resulting in overcurrent shut-off. When the overload current has decreased below stall prevention operation level, this function decreases the frequency again.		
<b>Check point</b>	<ol style="list-style-type: none"> <li>1) Check that the Pr. 0 "Torque boost" setting is not too large.</li> <li>2) Check that the Pr. 7 "Acceleration time" and Pr. 8 "Deceleration time" settings are not too small.</li> <li>3) Check that the load is not too heavy.</li> <li>4) Are there any failure in peripheral devices?</li> <li>5) Check that the Pr. 13 "Starting frequency" is not too large.</li> </ol> <ul style="list-style-type: none"> <li>• Check the motor for use under overload.</li> </ul>			
<b>Corrective action</b>	<ol style="list-style-type: none"> <li>1) Increase or decrease the Pr. 0 "Torque boost setting" 1% by 1% and check the motor status. (Refer to section 6.2.1.)</li> <li>2) Set a larger value in Pr. 7 "Acceleration time" and Pr. 8 "Deceleration time". (Refer to section 6.11.1.)</li> <li>3) Reduce the load weight.</li> <li>4) Try advanced magnetic flux vector control, real sensorless vector control or vector control.</li> <li>5) Change the Pr. 14 "Load pattern selection" setting.</li> <li>6) Set stall prevention operation current in Pr. 22 "Stall prevention operation level". (The initial value is 110%.) The acceleration/deceleration time may change. Increase the stall prevention operation level with Pr. 22 "Stall prevention operation level", or disable stall prevention with Pr. 156 "Stall prevention operation selection". (Use Pr. 156 to set either operation continued or not at OL operation.)</li> </ol>			

<b>Operation Panel Indication</b>	oL		FR-PU04 FR-PU07	oL
<b>Name</b>	Stall prevention (overcurrent)			
<b>Description</b>	During deceleration	<ul style="list-style-type: none"> <li>• If the regenerative energy of the motor becomes excessive and exceeds the regenerative energy consumption capability, this function stops the decrease in frequency to prevent over voltage shut-off. As soon as the regenerative energy has decreased, deceleration resumes.</li> <li>• If the regenerative energy of the motor becomes excessive when regeneration avoidance function is selected (Pr. 882 = 1), this function increases the speed to prevent over voltage shut-off. (Refer to section 6.24.8.)</li> </ul>		
<b>Check point</b>	<ul style="list-style-type: none"> <li>• Check for sudden speed reduction.</li> <li>• Regeneration avoidance function (Pr. 882 to Pr. 886) is being used? (Refer to section 6.24.8).</li> </ul>			
<b>Corrective action</b>	The deceleration time may change. Increase the deceleration time using Pr. 8 "Deceleration time".			

<b>Operation Panel Indication</b>	PS	<i>PS</i>	FR-PU04 FR-PU07	PS
<b>Name</b>	PU Stop			
<b>Description</b>	Stop with the STOP/RESET key of the PU is set in Pr. 75 "Reset selection/disconnected PU detection/PU stop selection". (For Pr. 75, refer to section 6.21.1.)			
<b>Check point</b>	Check for a stop made by pressing the STOP/RESET key of the operation panel.			
<b>Corrective action</b>	Turn the start signal off and release with PU/EXT key.			

<b>Operation Panel Indication</b>	RB	<i>rb</i>	FR-PU04 FR-PU07	RB
<b>Name</b>	Regenerative brake prealarm			
<b>Description</b>	Appears if the regenerative brake duty reaches or exceeds 85% of the Pr. 70 "Special regenerative brake duty value". If the regenerative brake duty reaches 100%, a regenerative overvoltage (E. OV_) occurs. The RBP signal can be simultaneously output with the [RB] display. For the terminal used for the RBP signal output, assign the function by setting "7" (positive logic) or "107" (negative logic) in any of Pr. 190 to Pr. 196 (output terminal function selection). (see also section 6.14.5)			
<b>Check point</b>	<ul style="list-style-type: none"> <li>• Check that the brake resistor duty is not high.</li> <li>• Check that the Pr. 30 "Regenerative function selection" and Pr. 70 "Special regenerative brake duty" values are correct.</li> </ul>			
<b>Corrective action</b>	<ul style="list-style-type: none"> <li>• Increase the deceleration time (Pr. 8).</li> <li>• Check the Pr. 30 "Regenerative function selection" and Pr. 70 "Special regenerative brake duty" values.</li> </ul>			

<b>Operation Panel Indication</b>	TH	<i>TH</i>	FR-PU04 FR-PU07	TH
<b>Name</b>	Electronic thermal relay function prealarm			
<b>Description</b>	Appears if the integrating value of the Pr. 9 "Electronic thermal O/L relay" reaches or exceeds 85% of the preset level. If it reaches 100% of the Pr. 9 "Electronic thermal O/L relay" setting, a motor overload shut-off (E. THM) occurs. The THP signal can be simultaneously output with the [TH] display. For the terminal used for the THP signal output, assign the function by setting "8" (source logic) or "108" (sink logic) in any of Pr. 190 to Pr. 196 "Output terminal function selection". (Refer to section 6.14.5)			
<b>Check point</b>	<ol style="list-style-type: none"> <li>1) Check for large load or sudden acceleration.</li> <li>2) Is the Pr. 9 "Electronic thermal O/L relay" setting is appropriate? (Refer to section 6.12.1.)</li> </ol>			
<b>Corrective action</b>	<ol style="list-style-type: none"> <li>1) Reduce the load weight or the number of operation times.</li> <li>2) Set an appropriate value in Pr. 9 "Electronic thermal O/L relay". (Refer to section 6.12.1.)</li> </ol>			

<b>Operation Panel Indication</b>	MT	<i>MT</i>	FR-PU04	—
			FR-PU07	MT
<b>Name</b>	Maintenance signal output			
<b>Description</b>	Indicates that the cumulative energizing time of the inverter has reached a given time.			
<b>Check point</b>	The Pr. 503 "Maintenance timer" setting is larger than the Pr. 504 "Maintenance timer alarm output set time" setting. (Refer to section 6.25.3.)			
<b>Corrective action</b>	Setting "0" in Pr. 503 "Maintenance timer" erases the signal.			

<b>Operation Panel Indication</b>	<b>CP</b>		<b>FR-PU04</b>	—
			<b>FR-PU07</b>	<b>CP</b>
<b>Name</b>	Parameter copy			
<b>Description</b>	Appears when parameters are copied between models with capacities of 01800 or less and 02160 or more.			
<b>Check point</b>	Resetting of parameters 9, 30, 51, 52, 54, 56, 57, 70, 72, 80, 82, 90 to 94, 158, 455, 458 to 462, 557, 859, 860 and 893 is necessary.			
<b>Corrective action</b>	Set the initial value in Pr. 989 "Parameter copy alarm release".			

<b>Operation Panel Indication</b>	<b>SL</b>		<b>FR-PU04</b>	—
			<b>FR-PU07</b>	<b>SL</b>
<b>Name</b>	Speed limit indication (output during speed limit)			
<b>Description</b>	Output if the speed limit level is exceeded during torque control.			
<b>Check point</b>	<ul style="list-style-type: none"> <li>• Check that the torque command is not larger than required.</li> <li>• Check that the speed limit level is not low</li> </ul>			
<b>Corrective action</b>	<ul style="list-style-type: none"> <li>• Decrease the torque command.</li> <li>• Increase the speed limit level.</li> </ul>			

### Minor fault

When the protective function is activated, the output is not shut off. You can also output a minor fault signal by making parameter setting. (Set "98" in any of Pr. 190 to Pr. 196 "Output terminal function selection". (Refer to section 6.14.5.)

<b>Operation Panel Indication</b>	<b>PS</b>		<b>FR-PU04</b>	<b>FN</b>
			<b>FR-PU07</b>	
<b>Name</b>	Fan fault			
<b>Description</b>	For the inverter that contains a cooling fan, "FN" appears on the operation panel when the cooling fan stops due to a fault or different operation from the setting of Pr. 244 "Cooling fan operation selection".			
<b>Check point</b>	Check the cooling fan for a fault.			
<b>Corrective action</b>	Check for fan fault. Please contact your sales representative.			



**Major fault**

When the protective function is activated, the inverter output is shut off and an alarm is output.

<b>Operation Panel Indication</b>	E.OC1	<b>E.OC1</b>	FR-PU04 FR-PU07	OC during Accs
<b>Name</b>	Over current shut-off during acceleration			
<b>Description</b>	When the inverter output current reaches or exceeds approximately 220% of the rated current during acceleration, the protective circuit is activated to stop the inverter output.			
<b>Check point</b>	<ol style="list-style-type: none"> <li>1) Check for sudden acceleration.</li> <li>2) Check that the downward acceleration time is not long in vertical lift application.</li> <li>3) Check for output short circuit.</li> <li>4) Check that stall prevention operation is correct.</li> <li>5) Check that the regeneration is not performed frequently. (Check that the output voltage becomes larger than the reference voltage at regeneration and over current due to increase in motor current occurs.)</li> <li>6) Check that the power supply for RS-485 terminal is not shorted. (under vector control)</li> </ol>			
<b>Corrective action</b>	<ol style="list-style-type: none"> <li>1) Increase the acceleration time. (Shorten the downward acceleration time in vertical lift application.)</li> <li>2) When "E.OC1" is always lit at starting, disconnect the motor once and start the inverter. If "E.OC1" is still lit, contact your sales representative.</li> <li>3) Check the wiring to make sure that output short circuit does not occur.</li> <li>4) Perform a correct stall prevention operation. (Refer to section 6.7.4.)</li> <li>5) Set base voltage (rated voltage of the motor, etc.) in Pr. 19 "Base frequency voltage". (Refer to section 6.9.1.)</li> <li>6) Check RS-485 terminal connection. (under vector control)</li> </ol>			

<b>Operation Panel Indication</b>	E.OC2	<b>E.OC2</b>	FR-PU04 FR-PU07	Stedy Spd OC
<b>Name</b>	Over current shut-off during constant speed			
<b>Description</b>	When the inverter output current reaches or exceeds approximately 220% of the rated current during constant speed operation, the protective circuit is activated to stop the inverter output.			
<b>Check point</b>	<ol style="list-style-type: none"> <li>1) Check for sudden load change.</li> <li>2) Check for output short circuit.</li> <li>3) Check that stall prevention operation is correct.</li> <li>4) Check that the power supply for RS-485 terminal is not shorted. (under vector control)</li> </ol>			
<b>Corrective action</b>	<ol style="list-style-type: none"> <li>1) Keep load stable.</li> <li>2) Check the wiring to avoid output short circuit.</li> <li>3) Check that stall prevention operation setting is correct. (Refer to section 6.7.4.)</li> <li>4) Check RS-485 terminal connection. (under vector control)</li> </ol>			

Operation Panel Indication	E.OC3	<b>E.OC3</b>	FR-PU04 FR-PU07	OC During Dec
Name	Over current shut-off during deceleration or stop			
Description	When the inverter output current reaches or exceeds approximately 220% of the rated inverter current during deceleration (other than acceleration or constant speed), the protective circuit is activated to stop the inverter output.			
Check point	<ol style="list-style-type: none"> <li>1) Check for sudden speed reduction.</li> <li>2) Check for output short circuit.</li> <li>3) Check for too fast operation of the motor's mechanical brake.</li> <li>4) Check that stall prevention operation setting is correct.</li> <li>5) Check that the power supply for RS-485 terminal is not shorted. (under vector control)</li> </ol>			
Corrective action	<ol style="list-style-type: none"> <li>1) Increase the deceleration time.</li> <li>2) Check the wiring to avoid output short circuit.</li> <li>3) Check the mechanical brake operation.</li> <li>4) Check that stall prevention operation setting is correct. (Refer to section 6.7.4.)</li> <li>5) Check RS-485 terminal connection. (under vector control)</li> </ol>			

Operation Panel Indication	E.OV1	<b>E.OV1</b>	FR-PU04 FR-PU07	OV During Acc
Name	Regenerative over voltage shutoff during acceleration			
Description	If regenerative energy causes the inverter's internal main circuit DC voltage to reach or exceed the specified value, the protective circuit is activated to stop the inverter output. The circuit may also be activated by a surge voltage produced in the power supply system.			
Check point	Check for too slow acceleration. (e.g. during descending acceleration with lifting load)			
Corrective action	<ul style="list-style-type: none"> <li>• Decrease the acceleration time.</li> <li>• Use regeneration avoidance function (Pr. 882 to Pr. 886). (Refer to section 6.24.8.)</li> </ul>			

Operation Panel Indication	E.OV2	<b>E.OV2</b>	FR-PU04 FR-PU07	Stedy Spd OV
Name	Regenerative over voltage shut-off during constant speed			
Description	If regenerative energy causes the inverter's internal main circuit DC voltage to reach or exceed the specified value, the protective circuit is activated to stop the inverter output. The circuit may also be activated by a surge voltage produced in the power supply system.			
Check point	Check for sudden load change.			
Corrective action	<ul style="list-style-type: none"> <li>• Keep load stable.</li> <li>• Use the brake unit or power regeneration common converter (FR-CV) as required.</li> <li>• Use regeneration avoidance function (Pr. 882 to Pr. 886). (Refer to section 6.24.8.)</li> </ul>			

Operation Panel Indication	E.OV3	<b>E.OV3</b>	FR-PU04 FR-PU07	OV During Dec
Name	Regenerative over voltage shut-off during deceleration or stop			
Description	If regenerative energy causes the inverter's internal main circuit DC voltage to reach or exceed the specified value, the protective circuit is activated to stop the inverter output. The circuit may also be activated by a surge voltage produced in the power supply system.			
Check point	Check for sudden speed reduction.			
Corrective action	<ul style="list-style-type: none"> <li>• Increase the deceleration time. (Set the deceleration time which matches the inertia moment of the load)</li> <li>• Decrease the braking duty.</li> <li>• Use the brake unit or power regeneration common converter (FR-CV) as required.</li> <li>• Use regeneration avoidance function (Pr. 882 to Pr. 886). (Refer to section 6.24.8.)</li> </ul>			

<b>Operation Panel Indication</b>	E.THT		FR-PU04 FR-PU07	<b>Inv. Overload</b>
<b>Name</b>	Inverter overload shut-off (electronic thermal relay function) ①			
<b>Description</b>	If a current not less than 150% of the rated output current flows and overcurrent shut-off does not occur (220% or less), inverse-time characteristics cause the electronic thermal relay to be activated to stop the inverter output in order to protect the output transistors. (overload immunity 150% <sup>②</sup> 60s)			
<b>Check point</b>	Check the motor for use under overload.			
<b>Corrective action</b>	Reduce the load weight.			

① Resetting the inverter initializes the internal thermal integrated data of the electronic thermal relay function.

② When 200 % overload capacity is selected.

<b>Operation Panel Indication</b>	E.THM		FR-PU04 FR-PU07	<b>Motor Overload</b>
<b>Name</b>	Motor overload shut-off (electronic thermal relay function) ①			
<b>Description</b>	The electronic thermal relay function in the inverter detects motor overheat due to overload or reduced cooling capability during constant-speed operation and pre-alarm (TH display) is output when the temperature reaches 85% of the Pr. 9 "Electronic thermal O/L relay" setting and the protection circuit is activated to stop the inverter output when the temperature reaches the specified value. When running a special motor such as a multi-pole motor or multiple motors, provide a thermal relay on the inverter output side since such motor(s) cannot be protected by the electronic thermal relay function.			
<b>Check point</b>	1) Check the motor for use under overload. 2) Check that the setting of Pr. 71 "Applied motor" for motor selection is correct (refer to section 6.12.2) and check that the setting of the rated motor current in Pr. 9 is correct. 3) Check that stall prevention operation setting is correct. (Refer to section 6.7.4.)			
<b>Corrective action</b>	1) Reduce the load weight. 2) For a constant-torque motor, set the constant-torque motor in Pr. 71 "Applied motor". 3) Check that stall prevention operation setting is correct. (Refer to section 6.7.4.)			

① Resetting the inverter initializes the internal thermal integrated data of the electronic thermal relay function.

<b>Operation Panel Indication</b>	E.FIN		FR-PU04 FR-PU07	<b>H/Sink O/Temp</b>
<b>Name</b>	Fin overheat			
<b>Description</b>	If the heatsink overheats, the temperature sensor is actuated to stop the inverter output. The FIN signal can be output when the temperature becomes approximately 85% of the heatsink overheat protection operation temperature. For the terminal used for the FIN signal output, assign the function by setting "26" (source logic) or "126" (sink logic) in any of Pr. 190 to Pr. 196 "Output terminal function selection". (Refer to section 6.14.5.)			
<b>Check point</b>	1) Check for too high ambient temperature. 2) Check for heatsink clogging. 3) Check that the cooling fan is stopped. (Check that FN is displayed on the operation panel.)			
<b>Corrective action</b>	1) Set the ambient temperature to within the specifications. 2) Clean the heatsink. 3) Replace the cooling fan.			

Operation Panel Indication	E.IPF	<i>E.IPF</i>	FR-PU04 FR-PU07	Inst. Pwr. Loss
Name	Instantaneous power failure protection			
Description	If a power failure occurs for longer than 15ms (this also applies to inverter input shut-off), the instantaneous power failure protective function is activated to stop the inverter output in order to prevent the control circuit from malfunctioning. If a power failure persists for longer than 100ms, the alarm warning output is not provided, and the inverter restarts if the start signal is on upon power restoration. (The inverter continues operating if an instantaneous power failure is within 15ms.) In some operating status (load magnitude, acceleration/ deceleration time setting, etc.), over current or other protection may be activated upon power restoration. When instantaneous power failure protection is activated, the IPF signal is output. (Refer to section 6.16.)			
Check point	Find the cause of instantaneous power failure occurrence.			
Corrective action	<ul style="list-style-type: none"> <li>• Remedy the instantaneous power failure.</li> <li>• Prepare a backup power supply for instantaneous power failure.</li> <li>• Set the function of automatic restart after instantaneous power failure (Pr. 57). (Refer to section 6.16.1.)</li> </ul>			

Operation Panel Indication	E.BE	<i>E. BE</i>	FR-PU04 FR-PU07	Br. Cct. Fault
Name	Brake transistor alarm detection/internal circuit error			
Description	This function stops the inverter output if an alarm occurs in the brake circuit, e.g. damaged brake transistors. <b>In this case, the inverter must be powered off immediately.</b>			
Check point	<ul style="list-style-type: none"> <li>• Reduce the load inertia.</li> <li>• Check that the frequency of using the brake is proper.</li> </ul>			
Corrective action	Replace the inverter.			

Operation Panel Indication	E.UVT	<i>E.UVT</i>	FR-PU04 FR-PU07	Under Voltage
Name	Under voltage protection			
Description	If the power supply voltage of the inverter reduces, the control circuit will not perform normal functions. In addition, the motor torque will be insufficient and/or heat generation will increase. To prevent this, if the power supply voltage reduces below about 300V for the 400V class, this function stops the inverter output. When a jumper is not connected across P/+-P1, the under voltage protective function is activated. When undervoltage protection is activated, the IPF signal is output. (Refer to section 6.16.)			
Check point	<ol style="list-style-type: none"> <li>1) Check for start of large-capacity motor.</li> <li>2) Check that a jumper or DC reactor is connected across terminals P/+-P1.</li> </ol>			
Corrective action	<ol style="list-style-type: none"> <li>1) Check the power supply system equipment such as the power supply.</li> <li>2) Connect a jumper or DC reactor across terminals P/+-P1.</li> <li>3) If the problem still persists after taking the above measure, please contact your sales representative.</li> </ol>			

Operation Panel Indication	E.ILF		FR-PU04	Fault 14
			FR-PU07	Input phase loss
Name	Input phase failure			
Description	This alarm is output when function valid setting (=1) is set in Pr. 872 "Input phase failure protection selection" and one phase of the three phase power input opens. (Refer to section 6.17.3.)			
Check point	Check for a brake in the cable for the three-phase power supply input.			
Corrective action	<ul style="list-style-type: none"> <li>• Wire the cables properly.</li> <li>• Repair a brake portion in the cable.</li> <li>• Check the Pr. 872 "Input phase failure protection selection" setting.</li> </ul>			

Operation Panel Indication	E.OLT		FR-PU04	Stall Prev STP (OL shown during stall prevention operation)
			FR-PU07	
Name	Stall prevention			
Description	<p>If the frequency has fallen to 0.5Hz by stall prevention operation and remains for 3s, an alarm (E.OLT) appears to shutoff the inverter output. OL appears while stall prevention is being activated.</p> <p>When speed control is performed by real sensorless vector control or vector control, an alarm (E.OLT) is displayed and the inverter output is stopped if frequency drops to the Pr. 865 "Low speed detection" (initial value is 1.5Hz) setting by torque limit operation and the output torque exceeds Pr. 874 "OLT level setting" (initial value is 150%) setting and remains for more than 3s.</p>			
Check point	<ul style="list-style-type: none"> <li>• Check the motor for use under overload. (Refer to section 6.7.4).</li> <li>• Check that the Pr. 865 "Low speed detection" and Pr. 874 OLT level setting values are correct. (Check the Pr. 22 "Stall prevention operation level" setting if V/F control is exercised.)</li> </ul>			
Corrective action	<ul style="list-style-type: none"> <li>• Reduce the load weight.</li> <li>• Change the Pr. 22 "Stall prevention operation level", Pr. 865 "Low speed detection" and Pr. 874 "OLT level setting" values. (Check the Pr. 22 "Stall prevention operation level" setting if V/F control is exercised.)</li> </ul>			

Operation Panel Indication	E.GF		FR-PU04	Ground Fault
			FR-PU07	
Name	Output side earth fault over current protection			
Description	This function stops the inverter output if an earth fault over current flows due to an earth (ground) fault that occurred on the inverter's output (load) side.			
Check point	Check for an earth fault in the motor and connection cable.			
Corrective action	Remedy the earth fault portion.			

Operation Panel Indication	E.LF		FR-PU04	—
			FR-PU07	
Name	Output phase failure protection			
Description	This function stops the inverter output if one of the three phases (U, V, W) on the inverter's output side (load side) opens.			
Check point	<ul style="list-style-type: none"> <li>• Check the wiring (Check that the motor is normal.)</li> <li>• Check that the capacity of the motor used is not smaller than that of the inverter.</li> </ul>			
Corrective action	<ul style="list-style-type: none"> <li>• Wire the cables properly.</li> <li>• Check the Pr. 251 "Output phase failure protection selection" setting.</li> </ul>			

<b>Operation Panel Indication</b>	E.OHT	<i>E.OHT</i>	FR-PU04 FR-PU07	OH Fault
<b>Name</b>	External thermal relay operation <sup>①</sup>			
<b>Description</b>	If the external thermal relay provided for motor overheating protection, or the internally mounted temperature relay in the motor, etc. switches on (contacts open), the inverter output is stopped.			
<b>Check point</b>	<ul style="list-style-type: none"> <li>• Check for motor overheating.</li> <li>• Check that the value of 7 (OH signal) is set correctly in any of Pr. 178 to Pr. 189 "Input terminal function selection".</li> </ul>			
<b>Corrective action</b>	<ul style="list-style-type: none"> <li>• Reduce the load and operating duty.</li> <li>• Even if the relay contacts are reset automatically, the inverter will not restart unless it is reset.</li> </ul>			

<sup>①</sup> Functions only when any of Pr. 178 to Pr. 189 "Input terminal function selection" is set to OH.

<b>Operation Panel Indication</b>	E.PTC	<i>E.PTC</i>	FR-PU04 FR-PU07	Fault 14 PTC activated
<b>Name</b>	PTC thermistor operation			
<b>Description</b>	Appears when the motor overheating status is detected for 10s or more by the external PTC thermistor input connected to the terminal AU.			
<b>Check point</b>	<ul style="list-style-type: none"> <li>• Check the connection between the PTC thermistor switch and thermal protector.</li> <li>• Check the motor for operation under overload.</li> <li>• Is valid setting (= 63) selected in Pr. 184 "AU terminal function selection"?</li> </ul>			
<b>Corrective action</b>	Reduce the load weight. Reduce the load. You may also need to connect an additional series resistor between terminals SD and AU.			

<b>Operation Panel Indication</b>	E.OPT	<i>E.OPT</i>	FR-PU04 FR-PU07	Option Fault
<b>Name</b>	Option alarm			
<b>Description</b>	<ul style="list-style-type: none"> <li>• Appears when the AC power supply is connected to the terminal R/L1, S/L2, T/L3 accidentally when a high power factor converter is connected.</li> <li>• Appears when torque command by the plug-in option is selected using Pr. 804 "Torque command source selection" and no plug-in option is mounted.</li> <li>• Appears when the switch for the manufacturer setting of the plug-in option is changed.</li> </ul>			
<b>Check point</b>	<ul style="list-style-type: none"> <li>• Check that the AC power supply is not connected to the terminal R/L1, S/L2, T/L3 when a high power factor converter (FR-HC, MT-HC) or power regenerative common converter (FR-CV) is connected.</li> <li>• Check that the plug-in option for torque command setting is connected.</li> </ul>			
<b>Corrective action</b>	<ul style="list-style-type: none"> <li>• Check the parameter (Pr. 30) setting and wiring.</li> <li>• The inverter may be damaged if the AC power supply is connected to the terminal R/L1, S/L2, T/L3 when a high power factor converter is connected. Please contact your sales representative.</li> <li>• Check for connection of the plug-in option. Check the Pr. 804 "Torque command source selection" setting.</li> <li>• Return the switch for the manufacturer setting of the plug-in option to the initial status. (Refer to instruction manual of each option.)</li> </ul>			

<b>Operation Panel Indication</b>	E.OP3	<i>E.OP3</i>	FR-PU04 FR-PU07	<b>Option3 Fault</b>
<b>Name</b>	Communication option alarm			
<b>Description</b>	Stops the inverter output when a communication line error occurs in the communication option.			
<b>Check point</b>	<ul style="list-style-type: none"> <li>• Check for a wrong option function setting and operation.</li> <li>• Check that the plug-in option is plugged into the connector securely.</li> <li>• Check for a brake in the communication cable.</li> <li>• Check that the terminating resistor is fitted properly.</li> </ul>			
<b>Corrective action</b>	<ul style="list-style-type: none"> <li>• Check the option function setting, etc.</li> <li>• Connect the plug-in option securely.</li> <li>• Check the connection of communication cable.</li> </ul>			

<b>Operation Panel Indication</b>	E.1	<i>E. 1</i>	FR-PU04 FR-PU07	<b>Fault 1</b>
	E.2	<i>E. 2</i>		<b>Fault 2</b>
	E.3	<i>E. 3</i>		<b>Fault 3</b>
<b>Name</b>	Option alarm			
<b>Description</b>	<ul style="list-style-type: none"> <li>• Stops the inverter output if a contact fault, etc. of the connector between the inverter and communication option occurs or if a communication option is fitted to the connector 1 or 2.</li> <li>• Appears when the switch for the manufacturer setting of the plug-in option is changed.</li> </ul>			
<b>Check point</b>	<ul style="list-style-type: none"> <li>• Check that the plug-in option is plugged into the connector securely. (1 to 3 indicate the option connector numbers.)</li> <li>• Check for excess electrical noises around the inverter.</li> <li>• Check that the communication option is not fitted to the connector 1 or 2.</li> </ul>			
<b>Corrective action</b>	<ul style="list-style-type: none"> <li>• Connect the plug-in option securely.</li> <li>• Take measures against noises if there are devices producing excess electrical noises around the inverter. If the problem still persists after taking the above measure, please contact your sales representative or distributor.</li> <li>• Fit the communication option to the connector 3.</li> <li>• Return the switch for the manufacturer setting of the plug-in option to the initial status. (Refer to instruction manual of each option.)</li> </ul>			

<b>Operation Panel Indication</b>	E.PE	<i>E. PE</i>	FR-PU04 FR-PU07	<b>Corrupt Memry</b>
<b>Name</b>	Parameter storage device alarm (control circuit board)			
<b>Description</b>	A fault occurred in parameters stored (E <sup>2</sup> PROM failure).			
<b>Check point</b>	Check for too many number of parameter write times.			
<b>Corrective action</b>	<p>Please contact your sales representative.</p> <p>When performing parameter write frequently for communication purposes, set "1" in Pr. 342 to enable RAM write. Note that powering off returns the inverter to the status before RAM write.</p>			

Operation Panel Indication	E.PE2	E.PE2	FR-PU04	Fault 14
			FR-PU07	PR storage alarm
Name	Parameter storage device alarm (main circuit board)			
Description	A fault occurred in parameters stored (E <sup>2</sup> PROM failure).			
Check point	—			
Corrective action	Please contact your sales representative.			

Operation Panel Indication	E.PUE	E.PUE	FR-PU04	PU Leave Out
			FR-PU07	
Name	PU disconnection			
Description	This function stops the inverter output if communication between the inverter and PU is suspended, e.g. the operation panel and parameter unit is disconnected, when "2", "3", "16" or "17" was set in Pr. 75 "Reset selection/disconnected PU detection/PU stop selection". This function stops the inverter output when communication errors occurred consecutively for more than permissible number of retries when a value other than "9999" is set in Pr. 121 "Number of PU communication retries" during the RS-485 communication with the PU connector. This function also stops the inverter output if communication is broken for the period of time set in Pr. 122 "PU communication check time interval".			
Check point	<ul style="list-style-type: none"> <li>• Check that the FR-DU07 or parameter unit (FR-PU04/FR-PU07) is fitted tightly.</li> <li>• Check the Pr. 75 setting.</li> </ul>			
Corrective action	Fit the FR-DU07 or parameter unit (FR-PU04/FR-PU07) securely.			

Operation Panel Indication	E.RET	E.RET	FR-PU04	Retry No Over
			FR-PU07	
Name	Retry count excess			
Description	If operation cannot be resumed properly within the number of retries set, this function stops the inverter output.			
Check point	Find the cause of alarm occurrence.			
Corrective action	Eliminate the cause of the error preceding this error indication.			

Operation Panel Indication	E. 6	E. 6	FR-PU04 FR-PU07	Fault 6
	E. 7	E. 7		Fault 7
	E.CPU	E.CPU		CPU Fault
Name	CPU error			
Description	Stops the inverter output if the communication error of the built-in CPU occurs.			
Check point	Check for devices producing excess electrical noises around the inverter.			
Corrective action	<ul style="list-style-type: none"> <li>• Take measures against noises if there are devices producing excess electrical noises around the inverter.</li> <li>• Please contact your sales representative.</li> </ul>			



Operation Panel Indication	E.CTE		FR-PU04	—
			FR-PU07	E.CTE
Name	<ul style="list-style-type: none"> <li>• Operation panel power supply short circuit</li> <li>• RS-485 terminal power supply short circuit</li> </ul>			
Description	<p>When the operation panel power supply (PU connector) is shorted, this function shuts off the power output. At this time, the operation panel (parameter unit) cannot be used and RS-485 communication from the PU connector cannot be made. When the power supply for RS-485 terminal is shorted, this function shuts off the power output. At this time, communication from the RS-485 terminal cannot be made. To reset, enter the RES signal or switch power off, then on again.</p>			
Check point	<ol style="list-style-type: none"> <li>1) Check for a short circuit in the PU connector cable.</li> <li>2) Check that the RS 485 terminal is connected correctly.</li> </ol>			
Corrective action	<ol style="list-style-type: none"> <li>1) Check the PU and cable.</li> <li>2) Check the connection of the RS-485 terminal.</li> </ol>			

Operation Panel Indication	E.MB1 to E.MB7		FR-PU04	—
			FR-PU07	E.MB1 Fault to E.MB7 Fault
Name	Brake sequence error			
Description	The inverter output is stopped when a sequence error occurs during use of the brake sequence function (Pr. 278 to Pr. 285).			
Check point	Find the cause of alarm occurrence.			
Corrective action	Check the set parameters and perform wiring properly.			

Operation Panel Indication	E.OS		FR-PU04 FR-PU07	E.OS
Name	Overspeed occurrence			
Description	Appears when the motor speed reaches and exceeds the overspeed setting level under encoder feedback control or vector control.			
Check point	<ul style="list-style-type: none"> <li>• Check that the Pr. 374 "Overspeed detection level value" is correct.</li> <li>• Check that the number of encoder pulses does not differ from the actual number of encoder pulses.</li> </ul>			
Corrective action	<ul style="list-style-type: none"> <li>• Set the Pr. 374 "Overspeed detection level" value correctly.</li> <li>• Set the correct number of encoder pulses in Pr. 369 "Number of encoder pulses".</li> </ul>			

Operation Panel Indication	E.OSD		FR-PU04 FR-PU07	E.OSd
Name	Speed deviation excess detection			
Description	Stops the inverter output if the motor speed is increased or decreased under the influence of the load etc. during vector control and cannot be controlled in accordance with the speed command value.			
Check point	<ul style="list-style-type: none"> <li>• Check that the values of Pr. 285 "Excessive speed deviation detection frequency" and Pr. 853 "Speed deviation time" are correct.</li> <li>• Check for sudden load change.</li> <li>• Check that the number of encoder pulses does not differ from the actual number of encoder pulses.</li> </ul>			
Corrective action	<ul style="list-style-type: none"> <li>• Set Pr. 285 "Excessive speed deviation detection frequency" and Pr. 853 "Speed deviation time" correctly.</li> <li>• Keep load stable.</li> <li>• Set the correct number of encoder pulses in Pr. 369 "Number of encoder pulses".</li> </ul>			

Operation Panel Indication	E.ECT	<i>E.ECT</i>	FR-PU04 FR-PU07	E.ECT
Name	Signal loss detection			
Description	Stops the inverter output when the encoder signal is shut off under orientation control, encoder feedback control or vector control.			
Check point	<ul style="list-style-type: none"> <li>• Check for the encoder signal loss.</li> <li>• Check that the encoder specifications are correct.</li> <li>• Check for a loose connector.</li> <li>• Check that the switch setting of the FR-A7AP is correct.</li> <li>• Check that the power is supplied to the encoder. Or, check that the power is not supplied to the encoder later than the inverter.</li> </ul>			
Corrective action	<ul style="list-style-type: none"> <li>• Remedy the signal loss.</li> <li>• Use an encoder that meets the specifications.</li> <li>• Make connection securely.</li> <li>• Make a switch setting of the FR-A7AP correctly. (Refer to page 3-35)</li> <li>• Supply the power to the encoder. Or supply the power to the encoder at the same time when the power is supplied to the inverter. If the power is supplied to the encoder after the inverter, check that the encoder signal is securely sent and set "0" in Pr. 376.</li> </ul>			

Operation Panel Indication	E.OD	<i>E. Od</i>	FR-PU04 FR-PU07	— E. Od
Name	Excessive position error			
Description	Indicates that the difference between the position command and position feedback exceeded the reference under position control.			
Check point	<ul style="list-style-type: none"> <li>• Check that the position detecting encoder mounting orientation matches the parameter.</li> <li>• Check that the load is not large.</li> <li>• Check that the Pr. 427 "Excessive level error" and Pr. 369 "Number of encoder pulses" are correct.</li> </ul>			
Corrective action	<ul style="list-style-type: none"> <li>• Check the parameters.</li> <li>• Reduce the load weight.</li> <li>• Set the Pr. 427 "Excessive level error" and Pr. 369 "Number of encoder pulses" correctly.</li> </ul>			

Operation Panel Indication	E.EP	<i>E.EP</i>	FR-PU04 FR-PU07	Fault 14 E.EP
Name	Encoder phase error			
Description	The rotation command of the inverter differs from the actual motor rotation direction detected from the encoder during offline auto tuning.			
Check point	<ul style="list-style-type: none"> <li>• Check for mis-wiring of the encoder cable.</li> <li>• Check for wrong setting of Pr. 359 "Encoder rotation direction".</li> </ul>			
Corrective action	<ul style="list-style-type: none"> <li>• Perform connection and wiring securely</li> <li>• Change the Pr. 359 "Encoder rotation direction value".</li> </ul>			

Operation Panel Indication	E.P24	<i>E.P24</i>	FR-PU04 FR-PU07	E.P24
Name	24V DC power output short circuit			
Description	When the 24V DC power output from the PC terminal is shorted, this function shuts off the power output. At this time, all external contact inputs switch off. The inverter cannot be reset by entering the RES signal. To reset it, use the operation panel or switch power off, then on again.			
Check point	Check for a short circuit in the PC terminal output.			
Corrective action	Remedy the earth (ground) fault portion.			

<b>Operation Panel Indication</b>	E.CDO		FR-PU04	Fault 14
			FR-PU07	OC detect level
<b>Name</b>	Output current detection value excess			
<b>Description</b>	This function is activated when the output current exceeds the Pr. 150 "Output current detection level" setting.			
<b>Check point</b>	Check the settings of Pr. 150 "Output current detection level", Pr. 151 "Output current detection signal delay time", Pr. 166 "Output current detection signal retention time", Pr. 167 "Output current detection operation selection".			

<b>Operation Panel Indication</b>	E.IOH		FR-PU04	Fault 14
			FR-PU07	Inrush overheat
<b>Name</b>	Inrush current limit circuit alarm			
<b>Description</b>	This function is activated when the resistor of the inrush current limit circuit overheats. The inrush current limit circuit failure.			
<b>Check point</b>	Check that frequent ON/OFF is not repeated.			
<b>Corrective action</b>	1) Connect a AC reactor. 2) Configure a circuit where frequent ON/OFF is not repeated. If the problem still persists after taking the above measure, please contact your sales representative			

<b>Operation Panel Indication</b>	E.SER		FR-PU04	Fault 14
			FR-PU07	VFD Comm error
<b>Name</b>	Communication error (inverter)			
<b>Description</b>	This function stops the inverter output when communication error occurs consecutively for more than permissible retry count when a value other than "9999" is set in Pr. 335 "RS-485 communication number of retries" during RS-485 communication from the RS-485 terminal. This function also stops the inverter output if communication is broken for the period of time set in Pr. 336 "RS-485 communication check time interval".			
<b>Check point</b>	Check the RS-485 terminal wiring.			
<b>Corrective action</b>	Perform wiring of the RS-485 terminal properly.			

<b>Operation Panel Indication</b>	E.AIE		FR-PU04	Fault 14
			FR-PU07	Analog in error
<b>Name</b>	Analog input error			
<b>Description</b>	Appears when 30mA or more is input or a voltage (7.5V or more) is input with the terminal 2/4 set to current input.			
<b>Check point</b>	Check the setting of Pr. 73 "Analog input selection" and Pr. 267 "Terminal 4 input selection".			
<b>Corrective action</b>	Either give a frequency command by current input or set Pr. 73 "Analog input selection" or Pr. 267 "Terminal 4 input selection" to voltage input. (Refer to section 6.20.2.)			

Operation Panel Indication	E.USB	E.USB	FR-PU04	Fault 14
			FR-PU07	USB comm error
Name	USB communication error			
Description	When the time set in Pr. 548 "USB communication check time interval" has broken, this function stops the inverter output.			
Check point	<ul style="list-style-type: none"> <li>• Check the USB communication cable.</li> <li>• Check the Pr. 548 "USB communication check time interval" setting.</li> </ul>			
Corrective action	<ul style="list-style-type: none"> <li>• Replace the USB communication cable.</li> <li>• Increase the Pr. 548 USB communication check time interval setting. Or, change the setting to 9999.(Refer to section 6-487)</li> </ul>			

Operation Panel Indication	E.11	E. 11	FR-PU04	Fault 11
			FR-PU07	
Name	Opposite rotation deceleration error			
Description	The speed may not decelerate during low speed operation if the rotation direction of the speed command and the estimated speed differ when the rotation is changing from forward to reverse or from reverse to forward under real sensorless vector control. At this time, the inverter output is stopped if the rotation direction will not change, causing overload.			
Check point	<ul style="list-style-type: none"> <li>• Check that the Pr. 71 "Applied motor" setting is appropriate.</li> <li>• Check that offline auto tuning and online auto tuning have been performed.</li> </ul>			
Corrective action	<ul style="list-style-type: none"> <li>• Check the setting of Pr. 71 "Applied motor".</li> <li>• Perform offline auto tuning, then online auto tuning.</li> </ul> Please contact your sales representative if these corrective actions are not successful.			

Operation Panel Indication	E.13	E. 13	FR-PU04	Fault 13
			FR-PU07	
Name	Internal circuit error			
Description	Appears when an internal circuit error occurred.			
Corrective action	Please contact your sales representative.			

**NOTES**

If protective functions of "E.ILF, E.PTC, E.PE2, E.EP, E.OD, E.CDO, E.IOH, E.SER, E.AIE or E.USB" are activated when using the FR-PU04, "Fault 14" appears.  
Also when the alarm history is checked on the FR-PU04, the display is "E.14".

If alarms other than the above appear, contact your sales representative.

### 7.3 Reset method of protective function

Eliminate the cause of the error before you reset the inverter. Note that the internal thermal integrated value of the electronic thermal relay function and the number of retries are cleared (erased) by resetting the inverter. It takes about 1s for reset.

The inverter can be reset by performing any of the following operations:

- Using the operation panel, press the STOP/RESET key to reset the inverter. (Enabled only when the inverter protective function is activated (major fault). (Refer to page 7-11 for major fault.))

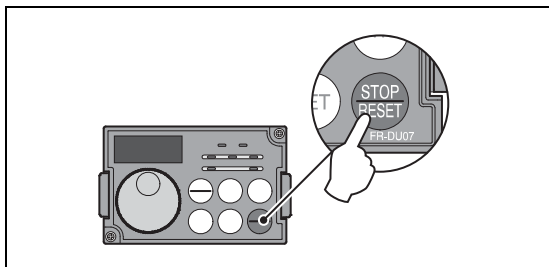

**Fig. 7-1:**  
Resetting the inverter by using the operation panel

1001296E

- Switch power off once, then switch it on again.

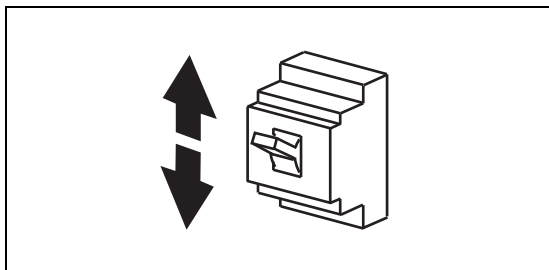

**Fig. 7-2:**  
Resetting the inverter by switching the power supply off an on

1001297E

- Turn on the reset signal RES for more than 0.1s. (Connect the terminals RES and SD when using sink logic or terminals RES and PC as shown Fig. 7-3 when using source logic). (If the RES signal is kept on, "Err." appears (flickers) to indicate that the inverter is in are set status.)

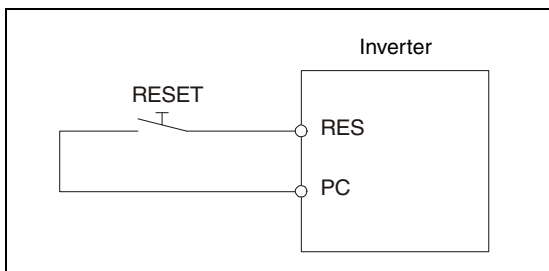

**Fig. 7-3:**  
Resetting the inverter by turning on the RES signal

1000249C

**NOTE**

For the 02160 or more, you can set Pr. 75 to disable reset operation until the thermal cumulative amount reaches 0 when a thermal trip (THM, THT) or an overcurrent trip (OC1 to OC3) occurs consecutively twice.

## 7.4 LED display

There are the following correspondences between the actual alphanumeric characters and the digital characters displayed on the operation panel.

0	0	A	A	L	L
1	1	B	b	M	n
2	2	C	c	N	n
3	3	D	d	O	0
4	4	E	E	P	P
5	5	F	F	R	r
6	6	G	G	S	5
7	7	H	H	T	c
8	8	I	i	U	U
9	9	J	J	V	U

1000299C

**Fig. 7-4:** Correspondences between digital and actual characters (FR-DU07)

# 7.5 Check and clear of the alarm history

## Check for the alarm (major fault) history

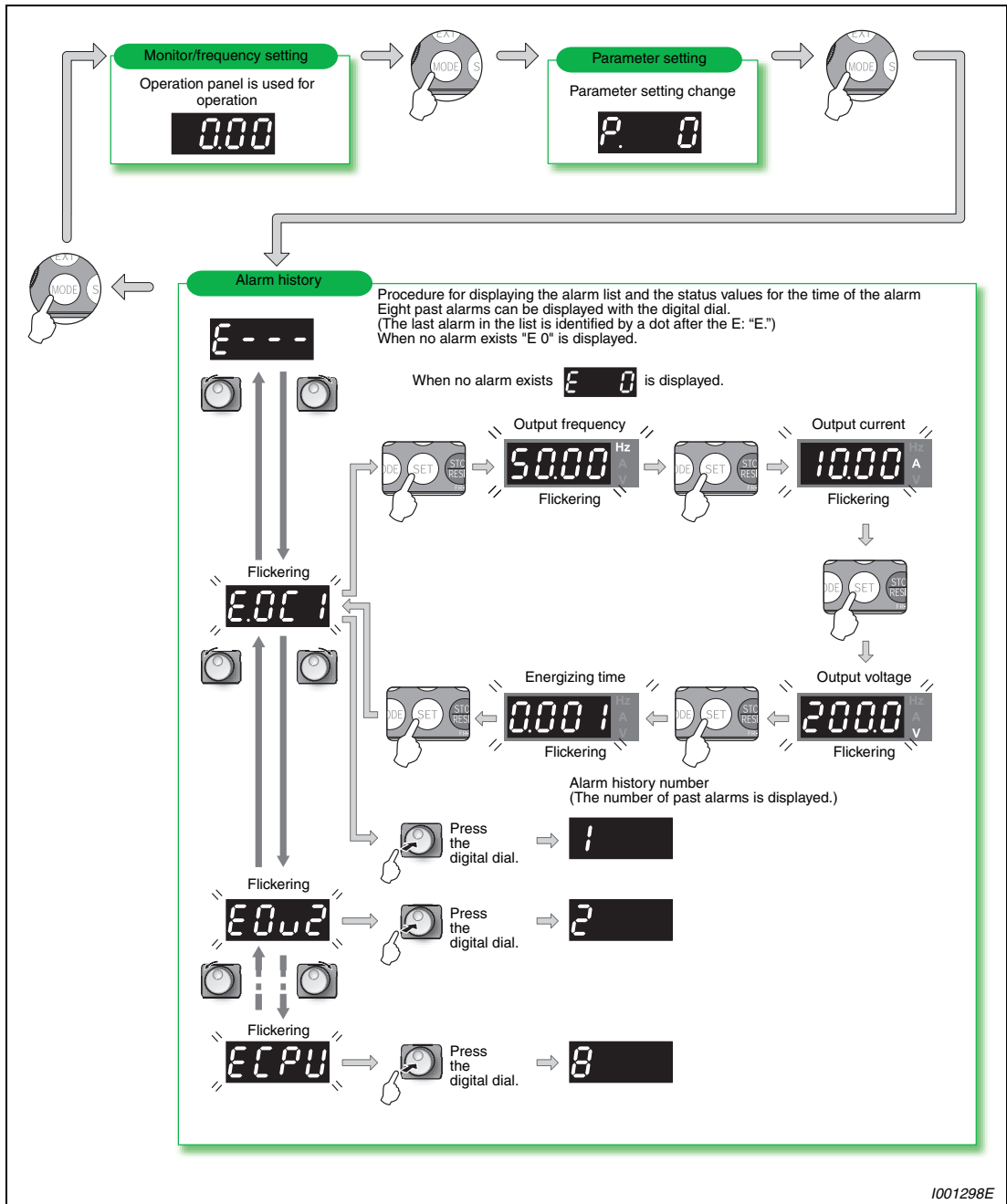
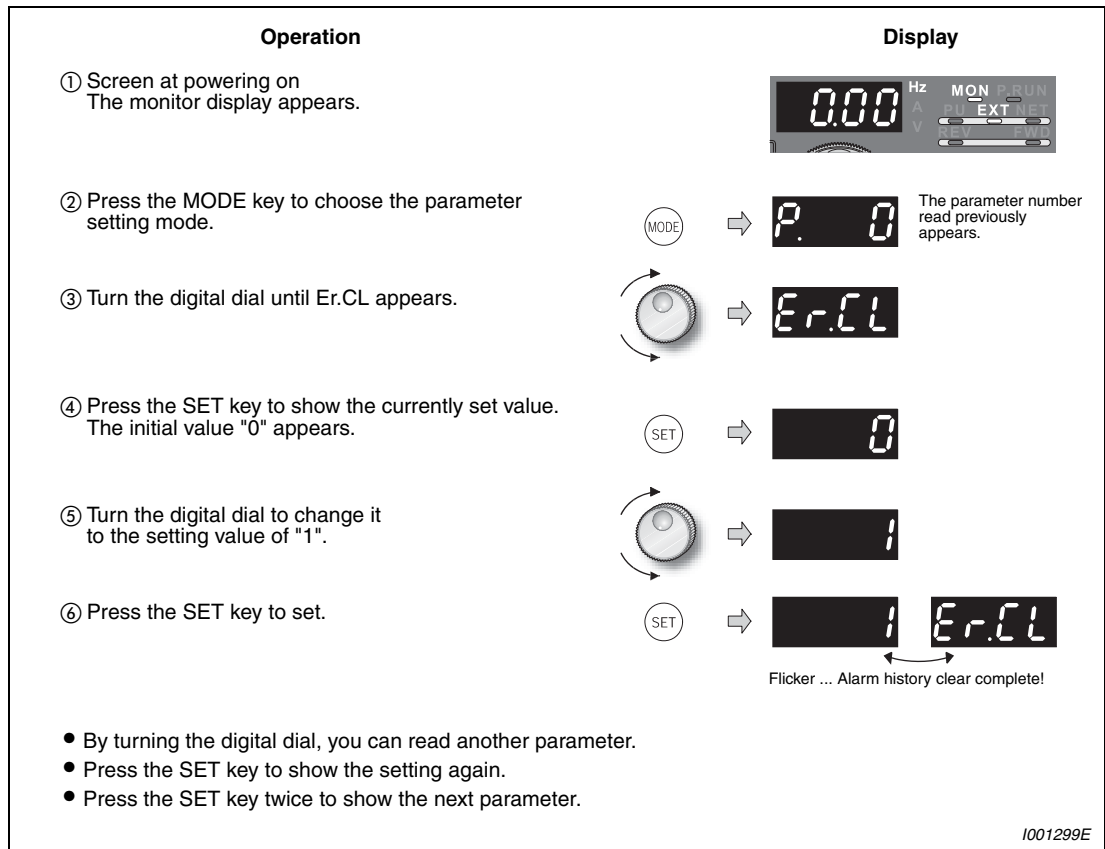

Fig. 7-5: Displaying the alarm list and the status values for the time of the alarm

**Clearing procedure**

The alarm history can be cleared by setting "1" in Er.CL "Alarm history clear". (The alarm history is not cleared when "1" is set in Pr. 77 "Parameter write selection".)



**Fig. 7-6:** Clearing the alarm history



## 7.6 Check first when you have troubles

### 7.6.1 Motor does not rotate as commanded

- Check the Pr. 0 "Torque boost". (Refer to section 6.2.1.)
- Check the main circuit.
  - Check that a proper power supply voltage is applied (operation panel display is provided).
  - Check that the motor is connected properly.
  - Check that the jumper across P/+-P1 is connected.
- Check the input signals.
  - Check that the start signal is input.
  - Check that both the forward and reverse rotation start signals are not input simultaneously.
  - Check that the frequency setting signal is not zero. (When the frequency command is 0Hz and the start command is entered, FWD or REV LED on the operation panel flickers.)
  - Check that the AU signal is on when the frequency setting signal is 0 to 20mA.
  - Check that the output stop signal (MRS) or reset signal (RES) is not on.
  - Check that the CS signal is not OFF with automatic restart after instantaneous power failure function is selected (Pr. 57 ≠ 9999).
  - Check that the sink or source jumper connector is fitted securely.
  - Check that the encoder wiring is correct.
- Check the parameter settings.
  - Check that the reverse rotation prevention selection (Pr. 78) is not selected.
  - Check that the operation mode selection (Pr. 79) setting is correct.
  - Check that the bias and gain (calibration parameter C2 to C7) settings are correct.
  - Check that the starting frequency (Pr. 13) setting is not greater than the running frequency.
  - Check that frequency settings of each running frequency (such as multi-speed operation) are not zero.
  - Check that especially the maximum frequency (Pr.1) is not zero.
  - Check that the Pr. 15 "Jog frequency setting" is not lower than the Pr. 13 "Starting frequency" value.
  - Check that the Pr. 359 "Encoder rotation direction" setting under encoder feed back control or vector control is correct. Set "1" in Pr. 359 if "REV" on the operation panel is on when the forward command is given.
- Inspection of load.
  - Check that the load is not too heavy.
  - Check that the shaft is not locked.

### 7.6.2 Motor generates abnormal noise

- No carrier frequency noises (metallic noises) are generated.
  - Soft-PWM operation to change the motor tone into an unoffending complex tone is factory-set to valid by the Pr. 72 "PWM frequency selection".  
Adjust Pr. 72 "PWM frequency selection" to change the motor tone.  
(When operating the inverter with the carrier frequency of 3kHz or more set in Pr. 72, the carrier frequency will automatically decrease if the output current of the inverter exceeds the value in parenthesis of the rated output current in appendix A. This may cause the motor noise to increase. But it is not a fault.)
  - Check for any mechanical looseness.
  - Contact the motor manufacturer.

### 7.6.3 Motor generates heat abnormally

- Is the fan for the motor is running? (Check for accumulated dust.)
- Check that the load is not too heavy. Lighten the load.
- Check that the inverter output voltages (U, V, W) balanced.
- Check that the Pr.0 "Torque boost" setting is correct.
- Was the motor type set? Check the setting of Pr. 71 "Applied motor".
- When using any other manufacturer's motor, perform offline auto tuning. (Please refer to section 6.12.3)

### 7.6.4 Motor rotates in opposite direction

- Check that the phase sequence of output terminals U, V and W is correct.
- Check that the start signals (forward rotation, reverse rotation) are connected properly. (Refer to section 6.14.4.)

### 7.6.5 Speed greatly differs from the setting

- Check that the frequency setting signal is correct. (Measure the input signal level.)
- Check that Pr. 1, Pr. 2, Pr.19 and the calibration parameters C2 to C7 settings are correct.
- Check that the input signal lines are not affected by external noise. (Use shielded cables.)
- Check that the load is not too heavy. (The motor current can be read out by the operation panel FR-DU07 .)
- Check that the Pr. 31 to Pr. 36 (frequency jump) settings are correct.

### 7.6.6 Acceleration/deceleration is not smooth

- Check that the acceleration and deceleration time settings are not too short.
- Check that the load is not too heavy.
- Check that the torque boost (Pr. 0, Pr. 46, Pr. 112) setting is not too large to activate the stall function.

### 7.6.7 Motor current is large

- Check that the load is not too heavy.
- Check that the Pr. 0 "Torque boost" setting is correct.
- Check that the Pr. 3 "Base frequency" setting is correct.
- Check that the Pr. 14 "Load pattern selection" setting is appropriate.
- Check that the Pr. 19 "Base frequency voltage" is correct.

### 7.6.8 Speed does not increase

- Check that the maximum frequency (Pr. 1) setting is correct. (If you want to run the motor at 120 Hz or more, set Pr. 18 "High speed maximum frequency".) (Refer to the section 6.8.1.)
- If you are using analog set point signals check whether the gain (Pr. 125 and Pr. 126) is set correctly.
- Check that the load is not too heavy.  
(In agitators, etc., load may become heavier in winter.)
- Check that the torque boost (Pr. 0, Pr. 46, Pr. 112) setting is not too large to activate the stall function.
- Check that the brake resistor is not connected to terminals P/+ and P1 accidentally.

### 7.6.9 Speed varies during operation

When advanced magnetic flux vector control, real sensorless vector control, vector control or encoder feedback control is exercised, the output frequency varies with load fluctuation between 0 and 2Hz. This is a normal operation and is not a fault.

- Inspection of load
  - Check that the load is not varying.
- Check the input signals.
  - Check that the frequency setting signal is not varying.
  - Check that the frequency setting signal is not affected by noise. Input filter to the analog input terminal using Pr. 74 "Input filter time constant" and Pr. 822 "Speed setting filter 1".
  - Check for a malfunction due to undesirable currents when the transistor output unit is connected. (Refer to page 3-25.)

- Others
  - Check that the settings of Pr. 80 "Motor capacity and Pr. 81 "Number of motor poles" are correct to the inverter capacity and motor capacity under advanced magnetic flux vector control, real sensorless vector control or vector control.
  - Check that the wiring length is not exceeding 30 m when advanced magnetic flux vector control, real sensorless vector control or vector control is exercised. Perform offline auto tuning. (Refer to 6.12.3)
  - Check that the wiring length is not too long for V/F control.
  - Change the Pr. 19 "Base frequency voltage setting" (about 3%) under V/F control.

### 7.6.10 Operation mode is not changed properly

- Inspection of load
  - Check that the STF or STR signal is off. When it is on, the operation mode cannot be changed.
- Parameter setting
  - Check the Pr. 79 setting. When the Pr. 79 "Operation mode selection" setting is "0" (initial value), the inverter is placed in the external operation mode at input power-on. At this time, pressing the button PU/EXT on the operation panel switches the mode to the PU operation mode. For other values (1 to 4, 6, 7), the operation mode is limited accordingly.

### 7.6.11 Operation panel (FR-DU07) display is not operating

- Check that the correct mains power supply is connected to terminals R1/L11 and S1/ L21.
- Check that the operation panel is connected to the inverter securely.

### 7.6.12 POWER lamp is not lit

- Check that wiring is securely performed and installation is correct.

### 7.6.13 Parameter write cannot be performed

- Make sure that operation is not being performed (signal STF or STR is not ON).
- Make sure that you are not attempting to set the parameter in the external operation mode.
- Check Pr. 77 "Parameter write selection".
- Check Pr. 161 "Frequency setting/key lock operation selection".

## 7.7 Meters and measuring methods

Since voltages and currents in the primary and secondary side of the inverter include harmonics, different meters indicate different measured values. When making measurement with the meters designed for commercial frequency, use the following measuring instruments and circuits:

When installing meters etc. on the inverter output side

When the inverter-to-motor wiring length is large, especially in the 400 V class, small-capacity models, the meters and CTs may generate heat due to line-to-line leakage current. Therefore, choose the equipment which has enough allowance for the current rating.

When measuring and indicating the output voltage and output current of the inverter, it is recommended to utilize the AM-5 and CA-5 terminal output function of the inverter.

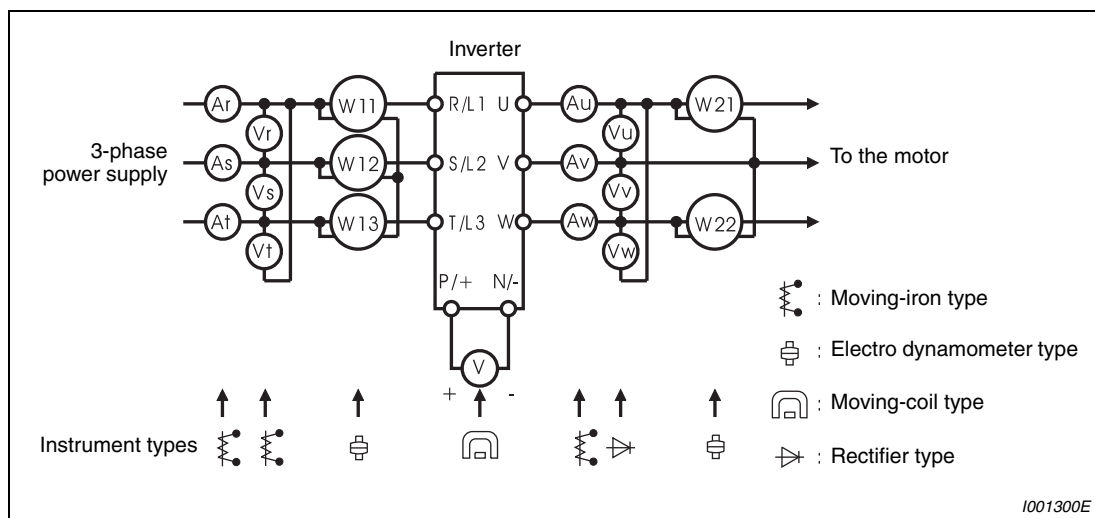

**Fig. 7-7:** Measurements at the main circuit

### 7.7.1 Measurement of powers

Using an electro-dynamometer type meter, measure the power in both the input and output sides of the inverter using the two- or three-wattmeter method. As the current is liable to be imbalanced especially in the input side, it is recommended to use the three-wattmeter method.

Examples of measured value differences produced by different measuring meters are shown below.

An error will be produced by difference between measuring instruments, e.g. power calculation type and two- or three-wattmeter type three-phase wattmeter. When a CT is used in the current measuring side or when the meter contains a PT on the voltage measurement side, an error will also be produced due to the frequency characteristics of the CT and PT.

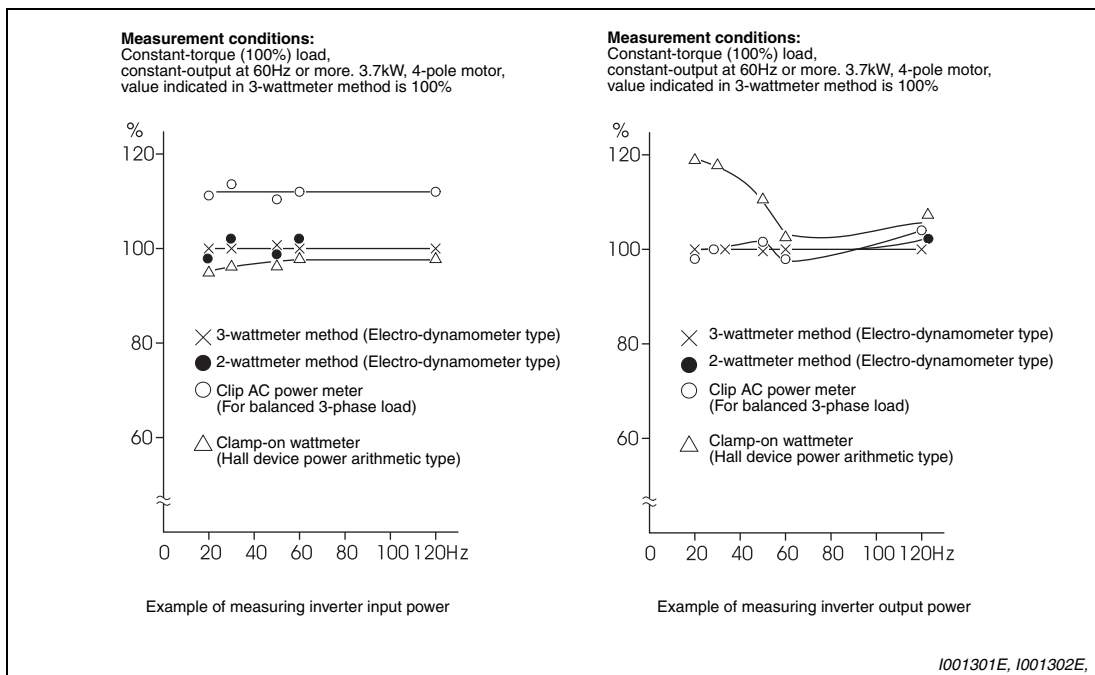

Fig. 7-8: Differences when measuring power with different instruments

### 7.7.2 Measurement of voltages and use of PT

#### Inverter input side

As the input side voltage has a sine wave and it is extremely small in distortion, accurate measurement can be made with an ordinary AC meter.

#### Inverter output side

Since the output side voltage has a PWM-controlled rectangular wave, always use a rectifier type voltmeter. A needle type tester can not be used to measure the output side voltage as it indicates a value much greater than the actual value. A moving-iron type meter indicates an effective value which includes harmonics and therefore the value is larger than that of the fundamental wave. The value monitored on the operation panel is the inverter-controlled voltage itself. Hence, that value is accurate and it is recommended to monitor values (provide analog output) using the operation panel.

#### PT

No PT can be used in the output side of the inverter. Use a direct-reading meter. (A PT can be used in the input side of the inverter.)

### 7.7.3 Measurement of currents

Use a moving-iron type meter on both the input and output sides of the inverter. However, if the carrier frequency exceeds 5 kHz, do not use that meter since an over current loss produced in the internal metal parts of the meter will increase and the meter may burn out. In this case, use an approximate-effective value type.

As the inverter input side current is easily imbalanced, measurement of currents in all three phases is recommended. Correct values can not be measured in one or two phases. On the other hand, the phase imbalanced ratio of the output side current must be within 10%.

When a clamp ammeter is used, always use an effective value detection type. A mean value detection type produces a large error and may indicate an extremely smaller value than the actual value. The value monitored on the operation panel is accurate if the output frequency varies, and it is recommended to monitor values (provide analog output) using the operation panel.

An example of the measurement value difference produced by different measuring meters is shown below.

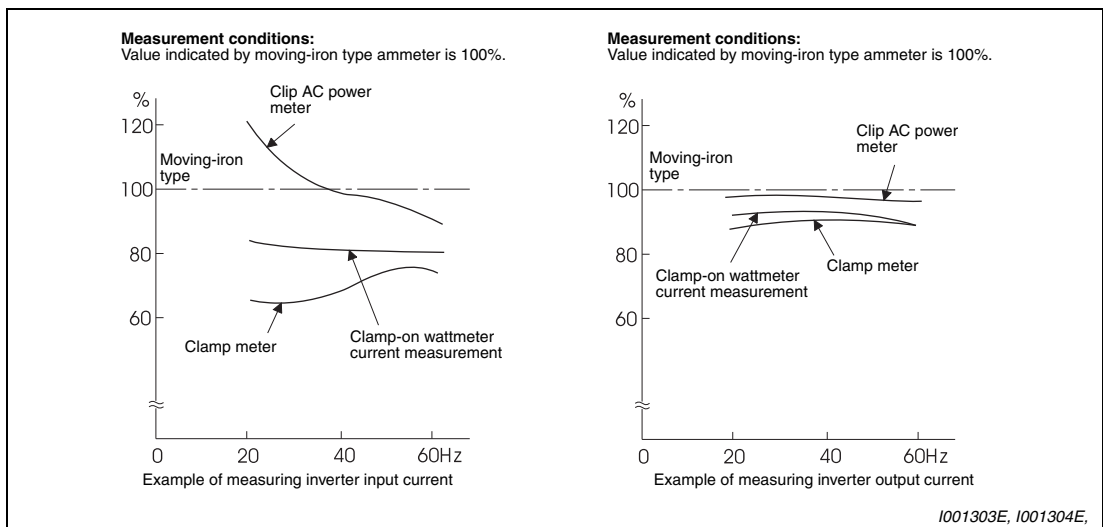

**Fig. 7-9:** Differences when measuring currents with different instruments

### 7.7.4 Use of CT and transducer

A CT may be used in both the input and output sides of the inverter, but the one used should have the largest possible VA ability because an error will increase if the frequency gets lower. When using a transducer, use the effective value calculation type which is immune to harmonics.

### 7.7.5 Measurement of inverter input power factor

Use the effective power and apparent power to calculate the inverter input power factor. A power-factor meter cannot indicate an exact value.

Total power factor of the inverter

$$\square \frac{\text{Effective power}}{\text{Apparent power}}$$
$$\square \frac{\text{3-phase input power found by 3-wattmeter method}}{\sqrt{3} \times V \text{ (power supply voltage)} \times I \text{ (input current effective value)}}$$

### 7.7.6 Measurement of converter output voltage (across terminals P/+ and N/-)

The output voltage of the converter is developed across terminals P/+ - N/- and can be measured with a moving-coil type meter (tester). Although the voltage varies according to the power supply voltage, approximately 540 V to 600 V is output when no load is connected and voltage decreases when a load is connected. When regenerative energy is returned from the motor during deceleration, for example, the converter output voltage rises to nearly 800 V to 900 V maximum.



## 8 Maintenance and inspection

The inverter is a static unit mainly consisting of semiconductor devices. Daily inspection must be performed to prevent any fault from occurring due to the adverse effects of the operating environment, such as temperature, humidity, dust, dirt and vibration, changes in the parts with time, service life, and other factors.



**WARNING:**

*Wait for a period of well over 10 minutes after disconnecting from the power supply before performing any service work on the frequency inverter. This is necessary so that the capacitors can discharge down to a safe level (< 25 V) after disconnection of the mains power. The LED indicator and the CHARGE LED inside the unit must both be off.*

### 8.1 Inspection

#### 8.1.1 Daily inspection

Basically, check for the following faults during operation:

- Motor operation fault
- Improper installation environment
- Cooling system fault
- Unusual vibration and noise
- Unusual overheat and discoloration

During operation, check the inverter input voltages using a tester.

#### 8.1.2 Periodic inspection

Check the areas inaccessible during operation and requiring periodic inspection. Consult us for periodic inspection.

- Check for cooling system fault . . . . . Clean the air filter, etc.
- Tightening check and retightening . . . . . The screws and bolts may become loose due to vibration, temperature changes, etc.  
Tighten them according to the specified tightening torque. (Refer to page 3-12.)
- Check the conductors and insulating materials for corrosion and damage.
- Measure insulation resistance.
- Check and change the cooling fan and relay.

### 8.1.3 Daily and periodic inspection

Area of Inspection	Inspection Item	Inspection Item	Interval		Method / Corrective Action	Customers's check	
			Daily	Periodic ②			
General	Surrounding environment	Check the ambient temperature, humidity, dirt, corrosive gas, oil mist , etc.	✓		Improve environment		
	Overall unit	Check for unusual vibration and noise.	✓		Check alarm location and retighten		
	Power supply voltage	Check that the main circuit voltages are normal. ①	✓		Inspect the power supply		
Main circuit	General	1) Check with megger (across main circuit terminals and earth (ground) terminal). 2) Check for loose screws and bolts. 3) Check for overheat traces on the parts. 4) Check for stain		✓ ✓ ✓ ✓	Contact the manufacturer Retighten Contact the manufacturer Clean		
	Conductors, cables	1) Check conductors for distortion. 2) Check cable sheaths for breakage		✓ ✓	Contact the manufacturer Contact the manufacturer		
	Transformer/ reactor	Check for unusual odor and abnormal increase in whining sound.	✓		Stop the device and contact the manufacturer.		
	Terminal block	Check for damage.		✓	Stop the device and contact the manufacturer.		
	Smoothing aluminum electrolytic capacitor	1) Check for liquid leakage. 2) Check for safety valve projection and bulge. 3) Visual check and judge by the life check of the main circuit capacitor (Refer to section 8.1.4.)		✓ ✓ ✓	Contact the manufacturer Contact the manufacturer		
	Relay/ contactor	Check that the operation is normal and no chatter is heard.		✓	Contact the manufacturer		
	Control circuit/Protective circuit	Operation check	1) Check that the output voltages across phases with the inverter operated alone is balanced. 2) Check that no fault is found in protective and display circuits in a sequence protective operation test.		✓ ✓	Contact the manufacturer Contact the manufacturer	
Parts check		Overall	1) Check for unusual odor and discoloration. 2) Check for serious rust development.		✓ ✓	Stop the device and contact the manufacturer. Contact the manufacturer	
		Aluminum electrolytic capacitor	1) Check for liquid leakage in a capacitor and deformation 2) Visual check and judge by the life check of the control circuit capacitor. (Refer to section 8.1.4.)		✓ ✓	Contact the manufacturer	
Cooling system	Cooling fan	1) Check for unusual vibration and noise. 2) Check for loose screws and bolts. 3) Check for stain.	✓	✓ ✓	Replace the fan Retighten Clean		
	Heatsink	1) Check for clogging. 2) Check for stain.		✓ ✓	Clean Clean		
	Air filter, etc.	1) Check for clogging. 2) Check for stain.		✓ ✓	Clean or replace Clean or replace		

**Tab. 8-1:** Daily and periodic inspection (1)

Area of Inspection	Inspection Item	Inspection Item	Interval		Method	Customer's check
			Daily	Periodic ②		
Display	Indication	1) Check that display is normal.	✓		Contact the manufacturer	
		2) Check for stain.		✓	Clean	
	Meter	Check that reading is normal.	✓		Stop the device and contact the manufacturer.	
Load motor	Operation check	Check for vibration and abnormal increase in operation noise.	✓		Stop the device and contact the manufacturer.	

**Tab. 8-1:** *Daily and periodic inspection (2)*

- ① It is recommended to install a device to monitor voltage for checking the power supply voltage to the inverter.
- ② One to two years of periodic inspection cycle is recommended. However, it differs according to the installation environment. Consult us for periodic inspection.

### 8.1.4 Display of the life of the inverter parts

The self-diagnostic alarm is output when the life span of the control circuit capacitor, cooling fan, each parts of the inrush current limit circuit is near to give an indication of replacement time. For the life check of the main circuit capacitor, the alarm signal (Y90) will not be output if a measuring method of is not performed. (Refer to the description below.)

The life alarm output can be used as a guideline for life judgement.

Parts	Judgement Level
Main circuit capacitor	85% of the initial capacity
Control circuit capacitor	Estimated 10% life remaining
Inrush current limit circuit	Estimated 10% life remaining (Power on: 100,000 times left)
Cooling fan	Less than 40% of the predetermined speed

**Tab. 8-2:** Guideline for the alarm signal output

#### Display of the life alarm

Pr. 255 "Life alarm status display" can be used to confirm that the control circuit capacitor, main circuit capacitor, cooling fan, and each parts of the inrush current limit circuit has reached the life alarm output level.

- ① Read the setting of parameter 255.

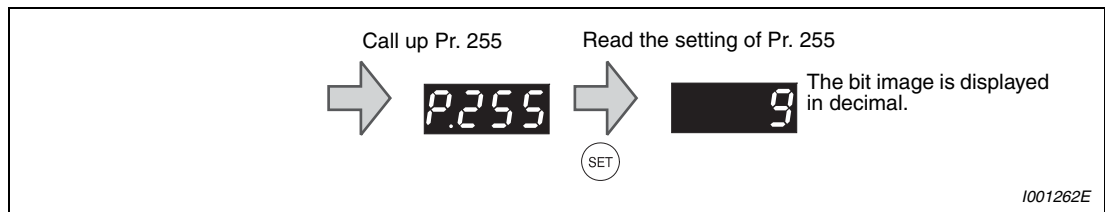

**Fig. 8-1:** Read parameter 255

- ② When the life alarm output level is reached, the bits are set as follows.

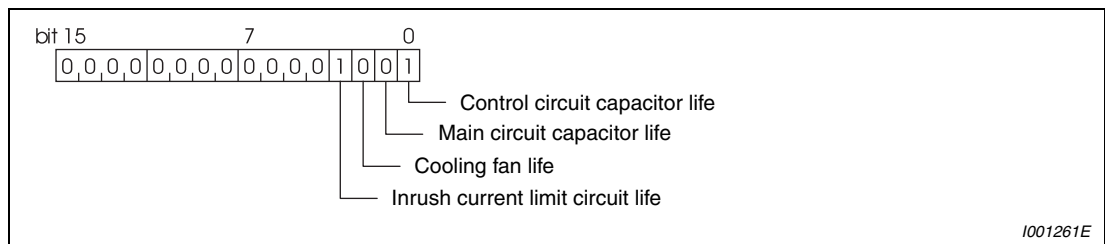

**Fig. 8-2:** Bits of parameter 255

Pr. 255 (decimal)	Bits (binary)	Inrush Current Limit Circuit Life	Cooling Fan Life	Main Circuit Capacitor Life	Control Circuit Capacitor Life
15	1111	✓	✓	✓	✓
14	1110	✓	✓	✓	—
13	1101	✓	✓	—	✓
12	1100	✓	✓	—	—
11	1011	✓	—	✓	✓
10	1010	✓	—	✓	—
9	1001	✓	—	—	✓
8	1000	✓	—	—	—
7	0111	—	✓	✓	✓
6	0110	—	✓	✓	—
5	0101	—	✓	—	✓
4	0100	—	✓	—	—
3	0011	—	—	✓	✓
2	0010	—	—	✓	—
1	0001	—	—	—	✓
0	0000	—	—	—	—

**Tab. 8-3:** Displaying the end of service life by bits

✓: End of the service life is reached

—: End of the service life is not reached

#### NOTE

Life check of the main circuit capacitor needs to be done by Pr. 259. (Refer to the following.)

#### Measuring method of life of the main circuit capacitor

On the assumption that the main circuit capacitor capacitance at factory shipment is 100%, the capacitor life is displayed in Pr. 258 every time measurement is made. When the measured value falls to or below 85%, Pr. 255 bit 1 is turned on and also an alarm is output to the Y90 signal.

Measure the capacitor capacity according to the following procedure and check the deterioration level of the capacitor capacity.

- ① Check that the motor is connected and at a stop.
- ② Set "1" (measuring start) in Pr. 259.
- ③ Switch power off. The inverter applies DC voltage to the motor to measure the capacitor capacity while the inverter is off.
- ④ After making sure that the power lamp is off, switch on the power supply again.
- ⑤ Check that "3" (measuring completion) is set in Pr. 259, read Pr 258, and check the deterioration degree of the main circuit capacitor

The life of the main circuit capacitor can not be measured in the following conditions:

- ① The FR-HC, MT-HC, FR-CV, FR-BU, MT-BU5 or BU is connected.
- ② Terminals R1/L11, S1/L21 or DC power supply is connected to the terminal P/+ and N/-.
- ③ Switch power on again during measuring.
- ④ The motor is not connected to the inverter.
- ⑤ The motor is running. (The motor is coasting.)
- ⑥ The motor capacity is two ranks (or more) smaller as compared to the inverter capacity.
- ⑦ The inverter is at an alarm stop or an alarm occurred while power is off.
- ⑧ The inverter output is shut off with the MRS signal.
- ⑨ The start command is given while measuring.

Operating environment: Ambient Temperature (annual average 40°C (free from corrosive gas, flammable gas, oil mist, dust and dirt))

Output current (80% of the rated current of Mitsubishi standard 4P motor)

**NOTE**

For the accurate life measuring of the main circuit capacitor, perform after more than 3h passed since the turn off of the power as it is affected by the capacitor temperature.

### 8.1.5 Checking the inverter and converter modules

Disconnect the external power supply cables (R/L1, S/L2, T/L3) and motor cables (U, V, W). Prepare a tester. (Use 100Ω range.)

Change the polarity of the tester alternately at the inverter terminals R/L1, S/L2, T/L3, U, V, W, P/+ and N/−, and check for continuity.



**CAUTION:**  
*Before measurement, check that the smoothing capacitor is discharged.*

At the time of discontinuity, due to the smoothing capacitor, the tester may not indicate ∞. At the time of continuity, the measured value is several to several ten's-of ohms depending on the module type, circuit tester type, etc. If all measured values are almost the same, the modules are without fault.

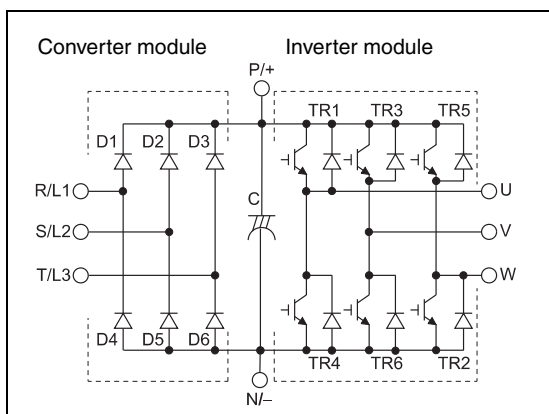

**Fig. 8-3:**  
*Module device numbers and terminals to be checked*

1001305E

		Tester Polarity		Measured Value			Tester Polarity		Measured Value
		⊕	⊖				⊕	⊖	
Converter module	D1	R/L1	P/+	Discontinuity	D4	R/L1	N/−	Continuity	
		P/+	R/L1	Continuity		N/−	R/L1	Discontinuity	
	D2	S/L2	P/+	Discontinuity	D5	S/L2	N/−	Continuity	
		P/+	S/L2	Continuity		N/−	S/L2	Discontinuity	
	D3	T/L3	P/+	Discontinuity	D6	T/L3	N/−	Continuity	
		P/+	T/L3	Continuity		N/−	T/L3	Discontinuity	
Inverter module	TR1	U	P/+	Discontinuity	TR4	U	N/−	Continuity	
		P/+	U	Continuity		N/−	U	Discontinuity	
	TR3	V	P/+	Discontinuity	TR6	V	N/−	Continuity	
		P/+	V	Continuity		N/−	V	Discontinuity	
	TR5	W	P/+	Discontinuity	TR2	W	N/−	Continuity	
		P/+	W	Continuity		N/−	W	Discontinuity	

**Tab. 8-4:** *Continuity check of the modules*

### 8.1.6 Cleaning

Always run the inverter in a clean status. When cleaning the inverter, gently wipe dirty areas with a soft cloth immersed in neutral detergent or ethanol.



**CAUTION:**

*Do not use solvent, such as acetone, benzene, toluene and alcohol, as they will cause the inverter surface paint to peel off. The display, etc. of the operation panel (FR-DU07) and parameter unit (FR-PU04/FR-PU07) are vulnerable to detergent and alcohol. Therefore, avoid using them for cleaning.*

### 8.1.7 Replacement of parts

The inverter consists of many electronic parts such as semiconductor devices. The following parts may deteriorate with age because of their structures or physical characteristics, leading to reduced performance or fault of the inverter. For preventive maintenance, the parts must be replaced periodically. Use the life check function as a guidance of parts replacement.

Part Name	Standard Replacement Interval <sup>①</sup>	Description
Cooling fan	10 years	Replace (as required)
Main circuit smoothing capacitor	10 years	Replace (as required)
On-board smoothing capacitor	10 years	Replace the board (as required)
Relays	—	As required
Fuse (04320 or more)	10 years	Replace the fuse (as required)

**Tab. 8-5:** *Wearing parts*

<sup>①</sup> Replacement years for when the yearly average ambient temperature is 40°C (without corrosive gas, flammable gas, oil mist, dust and dirt etc.)

**NOTE**

For parts replacement, consult the nearest Mitsubishi FA Centre.



### Cooling fan

The replacement interval of the cooling fan used for cooling the parts generating heat such as the main circuit semiconductor is greatly affected by the ambient temperature. When unusual noise and/or vibration is noticed during inspection, the cooling fan must be replaced immediately.

Inverter Type	Fan Type	Units	
FR-A740	00083, 00126	MMF-06F24ES-RP1 BKO-CA1638H01	1
	00170 to 00380	MMF-08D24ES-RP1 BKO-CA1639H01	2
	00470, 00620	MMF-12D24DS-RP1 BKO-CA1619H01	1
	00770	MMF-09D24TS-RP1 BKO-CA1640H01	2
	00930 to 01800	MMF-12D24DS-RP1 BKO-CA1619H01	2
	02160 to 03610		3
	04320, 04810	9LB1424H5H03	3
	05470 to 06830		4
	07700, 08660		5
	09620 to 12120	9LB1424S5H03	6

**Tab. 8-6:** Correspondence between inverters and cooling fans

#### NOTE

The inverters of the capacity classes 00023 to 00052 are not provided with a cooling fan.

● Removal of the fan (FR-A740-00083 to 03610)

- ① Push the hooks of the fan cover from above. Remove the fan cover.

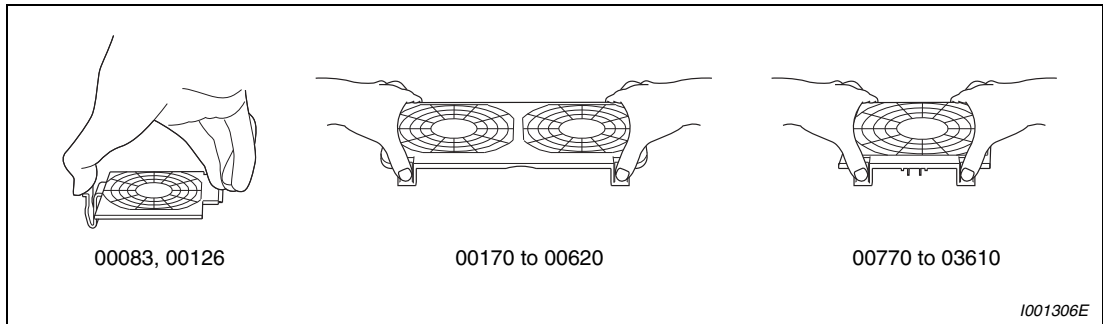

**Fig. 8-4:** Removal of the fan cover

- ② Disconnect the fan connector.  
③ Remove the fan.

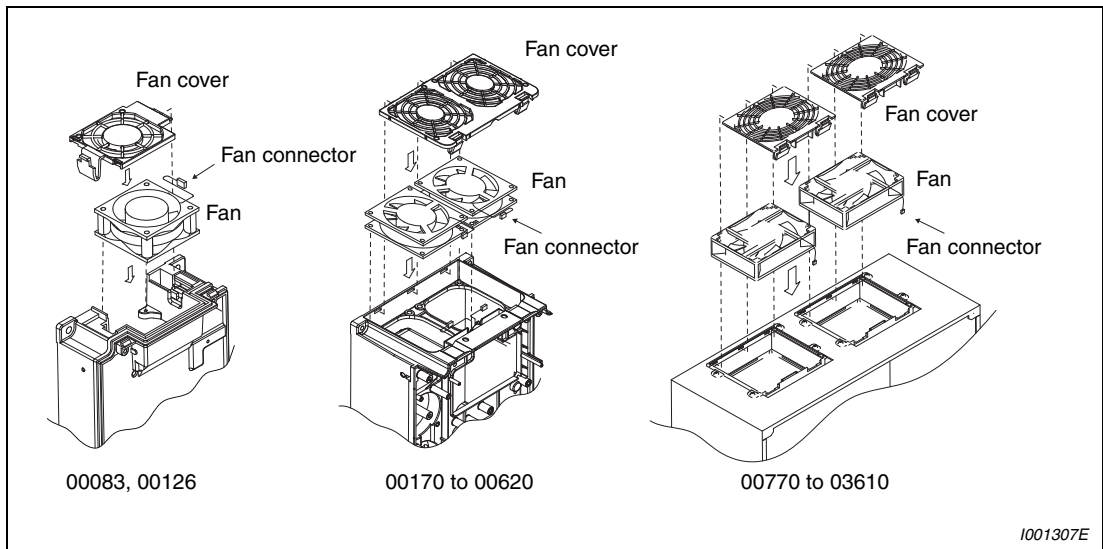
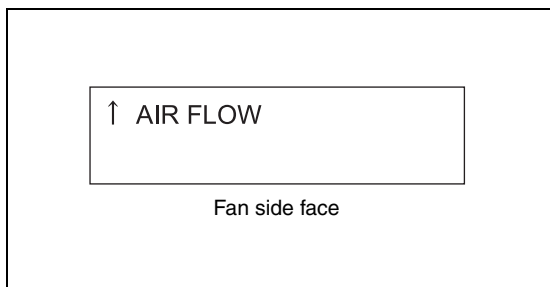

**Fig. 8-5:** Removal of the fan

**NOTE**

The number of cooling fans differs according to the inverter capacity (refer to Tab. 8-6).

- Reinstallation of the fan (FR-A740-00083 to 03610)
- ① After confirming the orientation of the fan, reinstall the fan so that the arrow on the left of "AIR FLOW" faces up.



**Fig. 8-6:**  
Orientation of the fan

I001334E

**NOTE**

Installing the fan in the opposite air flow direction can cause the inverter life to be shorter.

- ② Reconnect the fan connectors. When wiring, use care to avoid the cables being caught by the fan.

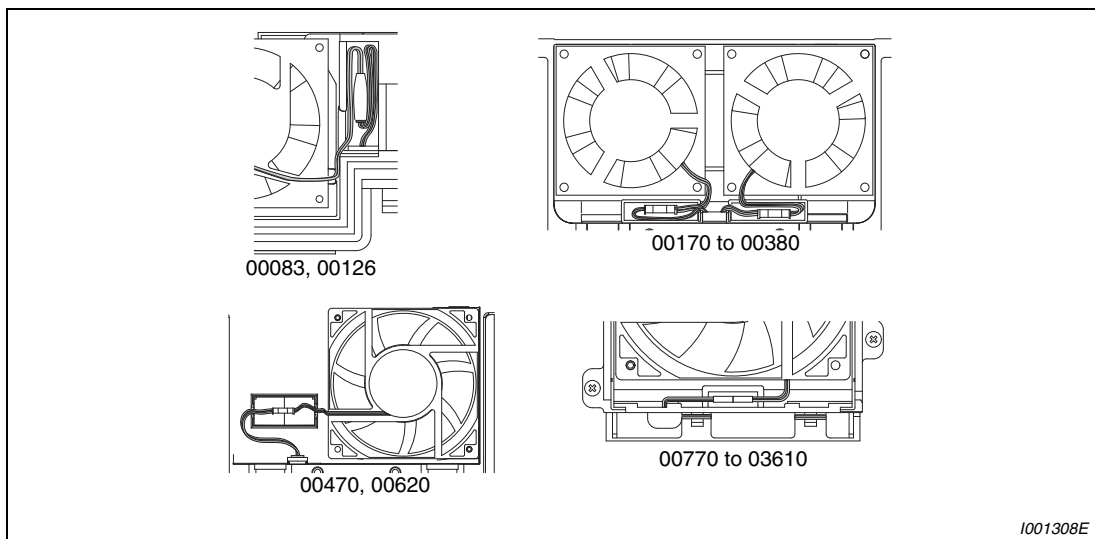

I001308E

**Fig. 8-7:** Connection of the fan

- ③ Reinstall the fan cover. Insert hooks into the holes ①. Insert hooks ② until you hear a click sound.

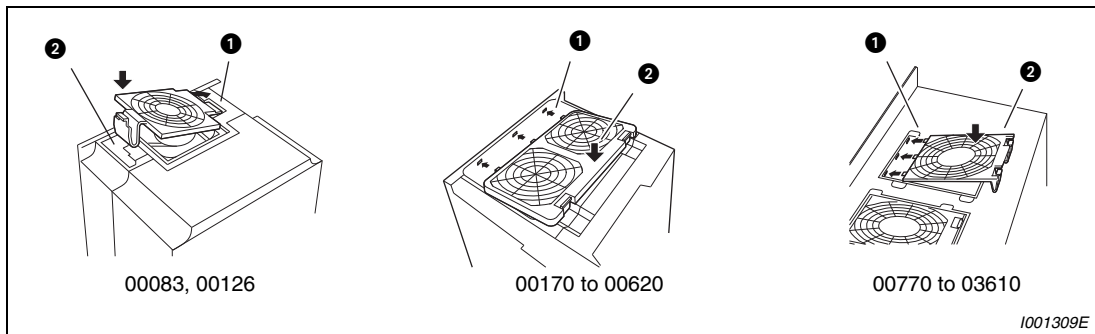

I001309E

**Fig. 8-8:** Reinstall the fan cover

● Removal of the fan (FR-A740-04320 or more)

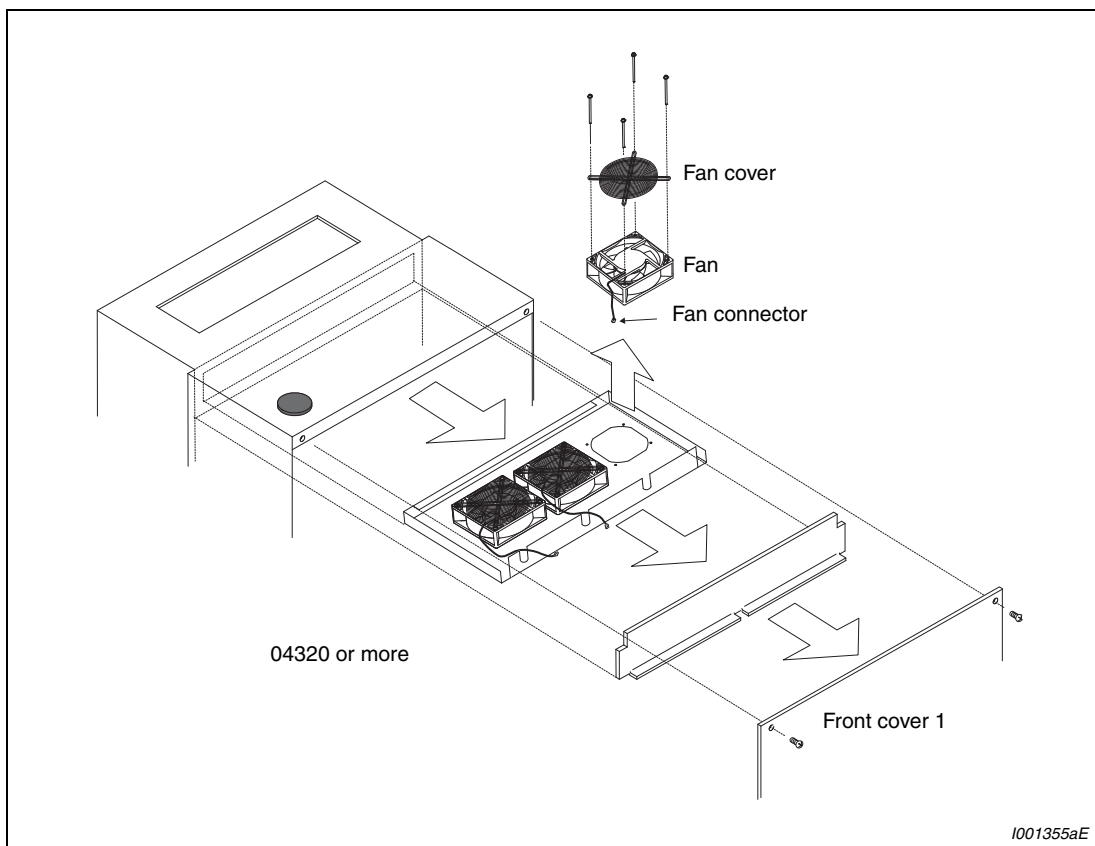

**Fig. 8-9:** Removal of the fan

**NOTE**

The number of cooling fans differs according to the inverter capacity (refer to Tab. 8-6).

● Reinstalltion of the fan (FR-A740-04320 or more)

- ① After confirming the orientation of the fan, reinstall the fan so that the arrow on the left of "AIR FLOW" faces up.

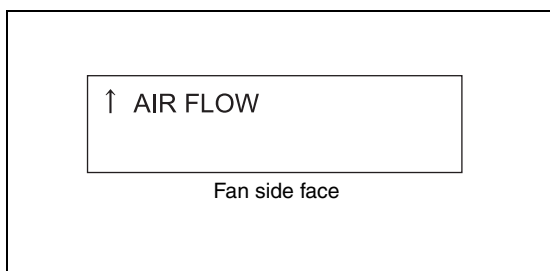

**Fig. 8-10:** Orientation of the fan

1001334E

**NOTE**

Installing the fan in the opposite air flow direction can cause the inverter life to be shorter.

- ② Install fans referring to Fig. 8-9. When installing the fan, use care to prevent wires from being caught between the inverter and fan.

### Replacement procedure of the cooling fan when using a heatsink protrusion attachment (FR-A7CN)

When replacing a cooling fan, remove a top cover of the heatsink protrusion attachment and perform replacement. After replacing the cooling fan, replace the top cover in the original position.

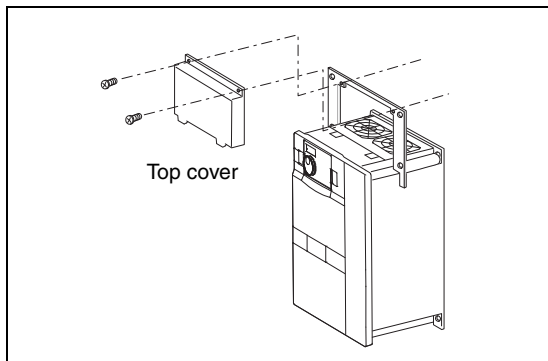

**Fig. 8-11:**

*Replacement procedure of the cooling fan when using a heatsink protrusion attachment*

1001356E

### Smoothing capacitors

A large-capacity aluminum electrolytic capacitor is used for smoothing in the main circuit DC section, and an aluminum electrolytic capacitor is used for stabilizing the control power in the control circuit. Their characteristics are deteriorated by the adverse effects of ripple currents, etc.

The replacement intervals greatly vary with the ambient temperature and operating conditions. When the inverter is operated in air-conditioned, normal environment conditions, replace the capacitors about every 10 years.

The appearance criteria for inspection are as follows:

- Case: Check the side and bottom faces for expansion
- Sealing plate: Check for remarkable warp and extreme crack.
- Check for external crack, discoloration, fluid leakage, etc. Judge that the capacitor has reached its life when the measured capacitance of the capacitor reduced below 80% of the rating.

### Relays

To prevent a contact fault, etc., relays must be replaced according to the cumulative number of switching times (switching life).

## 8.1.8 Inverter replacement

The inverter can be replaced with the control circuit wiring kept connected. Before replacement, remove the wiring cover of the inverter.



**WARNING:**

**Before starting inverter replacement, switch power off, wait for at least 10 minutes, and then check the voltage with a tester and such to ensure safety.**

- ① Loosen the two installation screws in both ends of the control circuit terminal block. (These screws cannot be removed.) Pull down the terminal block from behind the control circuit terminals.

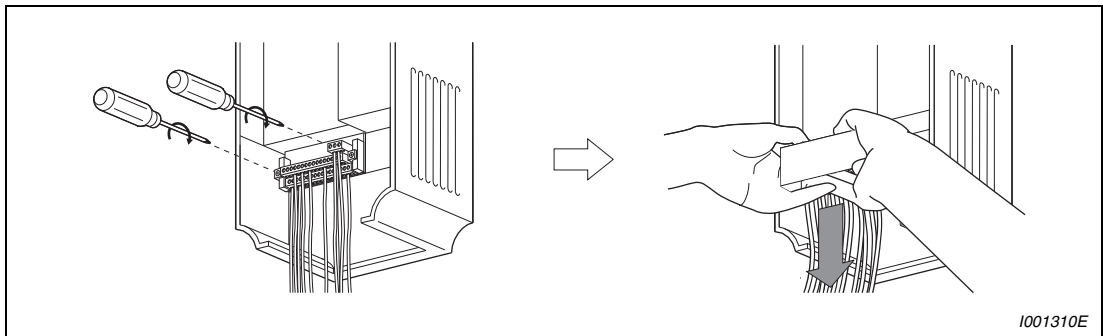

**Fig. 8-12: Removal of the terminal block**

- ② Using care not to bend the pins of the inverter's control circuit connector, reinstall the control circuit terminal block and fix it with the mounting screws.

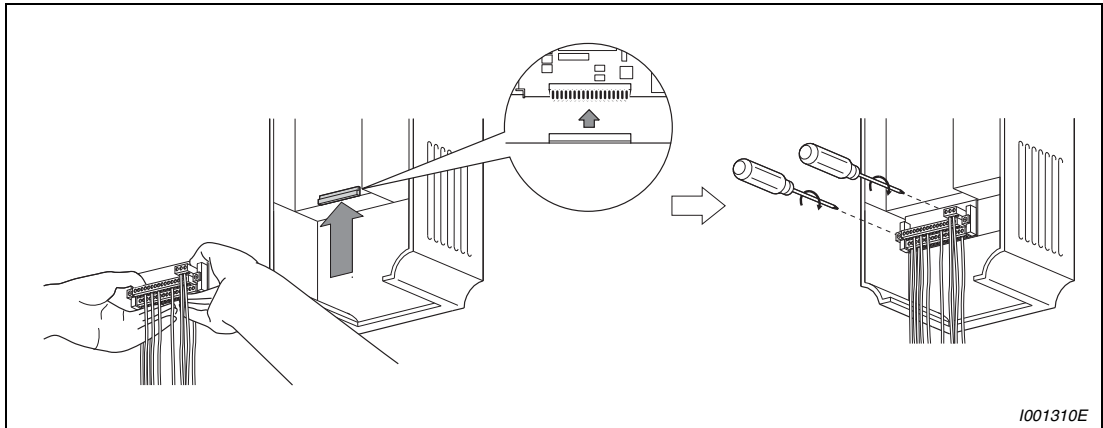

**Fig. 8-13: Reinstallation of the terminal block**

## 8.2 Measurements on the main circuit

This section describes the measurement of the main circuit voltages, currents, powers and insulation resistance.

### 8.2.1 Insulation resistance test using megger

For the inverter, conduct the insulation resistance test on the main circuit only as shown below and do not perform the test on the control circuit. (Use a 500V DC megger.)

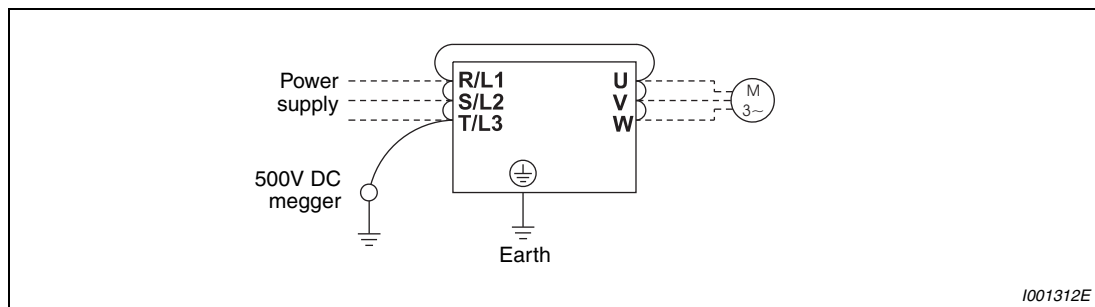

**Fig. 8-14:** Insulation resistance test



#### CAUTION:

**Before performing the insulation resistance test on the external circuit, disconnect the cables from all terminals of the inverter so that the test voltage is not applied to the inverter.**

#### NOTE

For the continuity test of the control circuit, use a tester (high resistance range) and do not use the megger or buzzer.

### 8.2.2 Pressure test

Do not conduct a pressure test. Deterioration may occur.

### 8.2.3 Measurement of voltages and currents

Since the voltages and currents on the inverter power supply and output sides include harmonics, measurement data depends on the instruments used and circuits measured.

When instruments for commercial frequency are used for measurement, measure the following circuits with the instruments given on the next page.

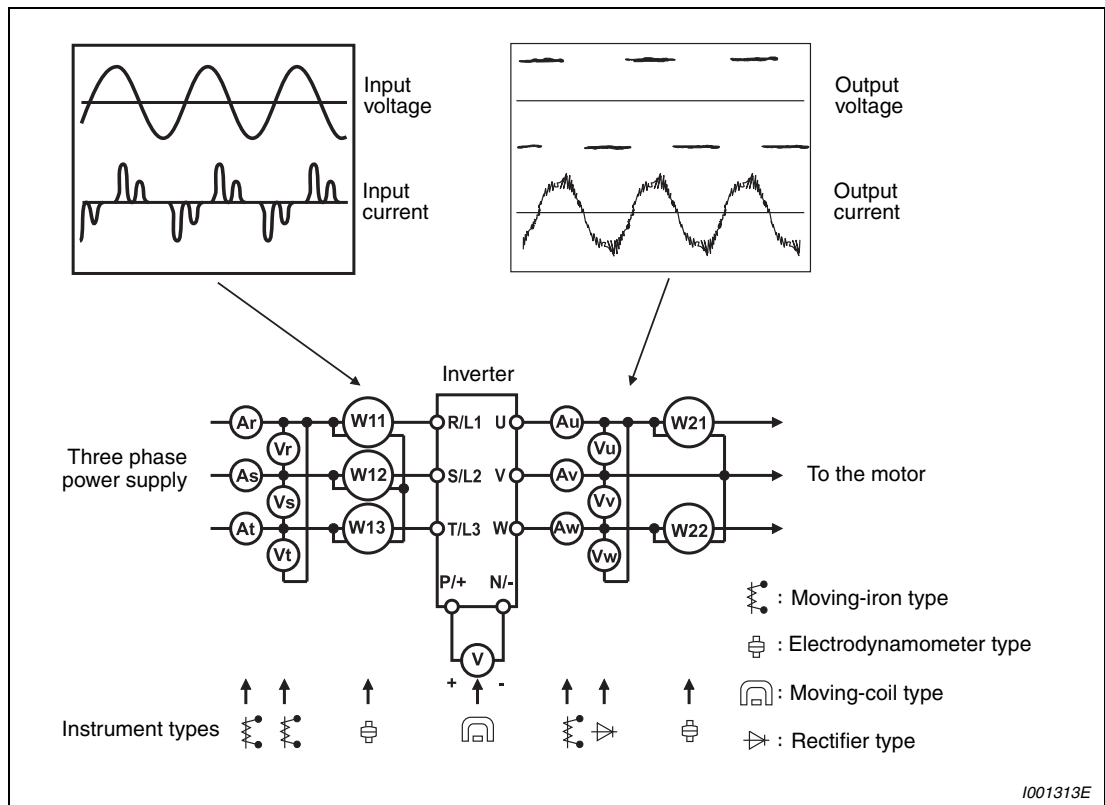

Fig. 8-15: Examples of measuring points and instruments



**Measuring Points and Instruments**

Item	Measuring Point	Measuring Instrument	Remarks (Reference Measurement Value)
Power supply voltage U1	Across R/L1-S/L2, S/L2-T/L3, T/L3-R/L1	Moving-iron type AC voltmeter	Commercial power supply Within permissible AC voltage fluctuation (Refer to appendix A)
Power supply side current I1	R/L1, S/L2, and T/L3 line currents	Moving-iron type AC ammeter	
Power supply side power P1	R/L1, S/L2, T/L3 and R/L1-S/L2, S/L2-T/L3, T/L3-R/L1	Electrodynamic type single-phase wattmeter	P1 = W11 + W12 + W13 (3-wattmeter method)
Power supply side power factor Pf1	Calculate after measuring power supply voltage, power supply side current and power supply side power. Pf1 = $\frac{P1}{\sqrt{3} \times U1 \times I1} \times 100\%$		
Output side voltage U2	Across U-V, V-W and W-U	Rectifier type AC voltage meter ① (Moving-iron type cannot measure)	Difference between the phases is within ±1% of the maximum output voltage
Output side current I2	U, V and W line currents	Moving-iron type AC ammeter ②	Difference between the phases is 10% or lower of the rated inverter current.
Output side power P2	U, V, W and U-V, V-W	Electrodynamic type single-phase wattmeter	P2 = W21 + W22 2-wattmeter method (or 3-wattmeter method)
Output side power factor Pf2	Calculate in similar manner to power supply side power factor. Pf2 = $\frac{P2}{\sqrt{3} \times U2 \times I2} \times 100\%$		
Converter output	Across P/+-N/-	Moving-coil type (such as tester)	Inverter LED display is lit. 1.35 × V1

**Tab. 8-7: Measuring Points and Instruments (1)**

Item	Measuring Point	Measuring Instrument	Remarks (Reference Measurement Value)									
Frequency setting signal	Across 2, 4 (positive) and 5	Moving-coil type (Tester and such may be used) (Internal resistance: 50kΩ or larger)	0–10 V DC, 4–20 mA	"5" is common								
	Across 1 (positive) and 5		0±5 V DC, 0–±10 V DC									
Frequency setting power supply	Across 10 (positive) and 5		5.2 V DC									
	Across 10E (positive) and 5		10 V DC									
Frequency meter signal	Across CA (positive) and 5		About 20mA at maximum frequency									
	Across AM (positive) and 5		Approximately 10V DC at maximum frequency (without frequency meter)									
Start signal Select signal	Across STF, STR, RH, RM, RL, JOG, RT, AU, STOP, CS and SD (0V)		When open: 20 to 30 V DC ON voltage: 1 V or less	"SD" is common (source logic)								
Reset	Across RES-SD (0V)											
Output stop	Across MRS-SD (0V)											
Alarm signal	Across A1-C1 and B1-C1	Moving-coil type (such as tester)	Continuity check ③ <table style="display: inline-table; vertical-align: middle;"> <tr> <td></td> <td>Normal</td> <td>Abnormal</td> </tr> <tr> <td>Across A1-C1</td> <td>Discontinuity</td> <td>Continuity</td> </tr> <tr> <td>Across B1-C1</td> <td>Continuity</td> <td>Discontinuity</td> </tr> </table>		Normal	Abnormal	Across A1-C1	Discontinuity	Continuity	Across B1-C1	Continuity	Discontinuity
	Normal	Abnormal										
Across A1-C1	Discontinuity	Continuity										
Across B1-C1	Continuity	Discontinuity										

**Tab. 8-7:** Measuring Points and Instruments (2)

- ① Use an FFT to measure the output voltage accurately. A tester or general measuring instrument cannot measure accurately.
- ② When the carrier frequency exceeds 5 kHz, do not use this instrument since using it may increase eddy-current losses produced in metal parts inside the instrument, leading to burnout. If the wiring length between the inverter and motor is long, the instrument and CT may generate heat due to line-to-line leakage current.
- ③ When the setting of Pr. 195 "ABC1 terminal function selection" is positive logic.

# A Appendix

## A.1 Specifications FR-A740-00023 to -01160

Series		00023	00038	00052	00083	00126	00170	00250	00310	00380	00470	00620	00770	00930	01160	
Rated motor capacity [kW] ①	200 % overload capacity	0.4	0.75	1.5	2.2	3.7	5.5	7.5	11	15	18.5	22	30	37	45	
Output	Output capacity [kVA] ②	1.1	1.9	3	4.6	6.9	9.1	13	17.5	23.6	29	32.8	43.4	54	65	
	Rated current [A] ③	120 % overload capacity	2.3 (1.9)	3.8 (3.2)	5.2 (4.4)	8.3 (7.0)	12.6 (10.7)	17 (14.4)	25 (21.2)	31 (26.3)	38 (32.3)	47 (39.9)	62 (52.7)	77 (65.4)	93 (79.0)	116 (98.6)
		150 % overload capacity	2.1 (1.7)	3.5 (2.9)	4.8 (4.0)	7.6 (6.4)	11.5 (9.7)	16 (13.6)	23 (19.5)	29 (24.6)	35 (29.7)	43 (36.5)	57 (48.4)	70 (59.5)	85 (72.2)	106 (90.1)
		200 % overload capacity	1.5	2.5	4	6	9	12	17	23	31	38	44	57	71	86
		250 % overload capacity	0.8	1.5	2.5	4	6	9	12	17	23	31	38	44	57	71
	Overload current rating ④	120 % overload capacity	120 % of rated motor capacity for 3 s; 110 % for 1 min. (max. ambient temperature 40°C)													
		150 % overload capacity	150 % of rated motor capacity for 3 s; 120 % for 1 min. (max. ambient temperature 50°C)													
		200 % overload capacity	200 % of rated motor capacity for 3 s; 150 % for 1 min. (max. ambient temperature 50°C)													
		250 % overload capacity	250 % of rated motor capacity for 3 s; 120 % for 1 min. (max. ambient temperature 50°C)													
	Voltage ⑤		3-phase AC, 0 V to power supply voltage													
Regenerative braking torque	Maximum value/ permissible duty	100 % torque / 2 % ED						20 % torque / continuous ⑥				20 % torque / continuous				
Power supply	Power supply voltage	3-phase, 380–480 V AC, –15% / +10%														
	Voltage range	323–528 V AC at 50/60 Hz														
	Power supply frequency	50/60 Hz ± 5%														
	Rated input capacity [kVA] ⑥	1.5	2.5	4.5	5.5	9	12	17	20	28	34	41	52	66	80	
Protective structure ⑦		IP20 ⑧											IP00			
Cooling system		Self cooling				Forced air cooling										
Weight [kg]		3.8	3.8	3.8	3.5	3.5	7.1	7.1	7.5	7.5	13	13	23	35	35	

**Tab. A-1:** Specifications FR-A740-00023 to -01160

- ① The applied motor capacity indicated is the maximum capacity applicable for use of the Mitsubishi 4-pole standard motor. 200 % overload capacity for 60 s is the default setting when the inverter is shipped.
- ② The rated output capacity indicated assumes that the output voltage is 440V.
- ③ When operating the inverter of 02160 or more with a value larger than 2 kHz set in Pr. 72 "PWM frequency selection", the rated output current is the value in parenthesis. When operating the inverter with the carrier frequency set to 3 kHz or more with 120 % or 150 % overload capacity set, the carrier frequency will automatically decrease if the output current of the inverter exceeds the value in parenthesis of the rated current (= 85 % load). This may cause the motor noise to increase.
- ④ The % value of the overload current rating indicated is the ratio of the overload current to the inverter's rated output current. For repeated duty, allow time for the inverter and motor to return to or below the temperatures under 100 % load.
- ⑤ The maximum output voltage does not exceed the power supply voltage. The maximum output voltage can be changed within the setting range. However, the pulse voltage value of the inverter output side voltage remains unchanged at about  $\sqrt{2}$  that of the power supply.

- ④ With the optional dedicated external brake resistor FR-ABR-H (option), the 00023 to 00250 and 00310 to 00620 will achieve the performance of 100 % torque/10 % ED and 100 % torque / 6 % ED respectively.
- ⑦ The power supply capacity varies with the value of the power supply side inverter impedance (including those of the input reactor and cables).
- ⑧ When the hook of the inverter front cover is cut off for installation of the plug-in option, the inverter changes to an open type (IP00).
- ⑨ FR-DU07: IP40 (except for the PU connector)

## A.2 Specifications FR-A740-01800 to -12120

Series		01800	02160	02600	03250	03610	04320	04810	05470	06100	06830	07700	08660	09620	10940	12120	
Rated motor capacity [kW] ①	200 % overload capacity	55	75	90	110	132	160	185	220	250	280	315	355	400	450	500	
Output	Output capacity [kVA] ②	84	110	137	165	198	248	275	329	367	417	465	521	587	660	733	
	Rated current [A] ③	120 % overload capacity	180 (153)	216 (184)	260 (221)	325 (276)	361 (306)	432 (367)	481 (408)	547 (464)	610 (518)	683 (580)	770 (654)	866 (736)	962 (817)	1094 (929)	1212 (1030)
		150 % overload capacity	144 (122)	180 (153)	216 (184)	260 (221)	325 (276)	361 (306)	432 (367)	481 (408)	547 (464)	610 (518)	683 (580)	770 (654)	866 (736)	962 (817)	1094 (929)
		200 % overload capacity	110	144 (122)	180 (153)	216 (184)	260 (221)	325 (276)	361 (306)	432 (367)	481 (408)	547 (464)	610 (518)	683 (580)	770 (654)	866 (736)	962 (817)
		250 % overload capacity	86	110 (93)	144 (122)	180 (153)	216 (184)	260 (221)	325 (276)	361 (306)	432 (367)	481 (408)	547 (464)	610 (518)	683 (580)	770 (654)	866 (736)
	Overload current rating ④	120 % overload capacity	120 % of rated motor capacity for 3 s; 110 % for 1 min. (max. ambient temperature 40°C)														
		150 % overload capacity	150 % of rated motor capacity for 3 s; 120 % for 1 min. (max. ambient temperature 50°C)														
		200 % overload capacity	200 % of rated motor capacity for 3 s; 150 % for 1 min. (max. ambient temperature 50°C)														
		250 % overload capacity	250 % of rated motor capacity for 3 s; 200 % for 1 min. (max. ambient temperature 50°C)														
	Voltage ⑤		3-phase AC, 0 V to power supply voltage														
Regenerative braking torque	Maximum value/permis- sible duty	20 % tor- que / conti- nuous	10 % torque / continuous														
Power supply	Power supply voltage	3-phase, 380–500 V AC, –15% / +10%															
	Voltage range	323–550 V AC at 50/60 Hz															
	Power supply frequency	50/60 Hz ± 5%															
	Rated input capacity [kVA] ⑥	100	110	137	165	198	248	275	329	367	417	465	521	587	660	733	
Protective structure ⑦		IP00															
Cooling system		Forced air cooling															
Weight [kg]		37	50	57	72	72	110	110	175	175	175	260	260	370	370	370	

**Tab. A-2:** Specifications FR-A740-01800 to -12120

- ① The applied motor capacity indicated is the maximum capacity applicable for use of the Mitsubishi 4-pole standard motor. 200 % overload capacity for 60 s is the default setting when the inverter is shipped.
- ② The rated output capacity indicated assumes that the output voltage is 440 V.
- ③ When operating the inverter with the carrier frequency set to 3 kHz or more with 120 % or 150 % overload capacity set, the carrier frequency will automatically decrease if the output current of the inverter exceeds the value in parenthesis of the rated current (= 85 % load). This may cause the motor noise to increase.
- ④ The % value of the overload current rating indicated is the ratio of the overload current to the inverter's rated output current. For repeated duty, allow time for the inverter and motor to return to or below the temperatures under 100% load.
- ⑤ The maximum output voltage does not exceed the power supply voltage. The maximum output voltage can be changed within the setting range. However, the pulse voltage value of the inverter output side voltage remains unchanged at about  $\sqrt{2}$  that of the power supply.
- ⑥ The power supply capacity varies with the value of the power supply side inverter impedance (including those of the input reactor and cables).
- ⑦ FR-DU07: IP40 (except for the PU connector)



## A.3 Common specifications

FR-A740		Specification	
Control specification	Control system	Soft-PWM control/high carrier frequency PWM control (selectable from among V/F control, advanced magnetic flux vector control and real sensorless vector control) / vector control (when used with option FR-A7AP)	
	Modulation control	Sine evaluated PWM, Soft PWM	
	Carrier frequency	0.2–400 Hz	
	Frequency setting resolution	Analog input	0.015 Hz/0–50 Hz (terminal 2, 4: 0–10 V/12 bit) 0.03 Hz/0–50 Hz/(terminal 2, 4: 0–5 V/11 bit, 0–20 mA /11 bit, terminal 1: 0–±10 V/12 bit) 0.06 Hz/0–50 Hz (terminal 1: 0–±5 V/11 bit)
		Digital input	0.01Hz
	Frequency accuracy	Analog input	±0.2% of the maximum output frequency (temperature range 25°C ± 10°C)
		Digital input	±0.01% of the set output frequency
	Voltage/frequency characteristics	Base frequency adjustable from 0 to 400Hz; selection between constant torque, variable torque or optional flexible 5-point V/f characteristics	
	Starting torque	200 % 0.3 Hz (0.4 kVA to 3.7 kVA), 150 % 0.3 Hz (5.5 kVA or more) under real sensorless vector control or vector control	
	Torque boost	Manual torque boost	
	Acceleration/deceleration time	0; 0.1 to 3600 s (can be set individually)	
	Acceleration/deceleration characteristics	linear or S-pattern acceleration/deceleration mode, backlash measures acceleration/deceleration can be selected	
	DC injection brake	Operating frequency (0–120 Hz), operating time ( 0–10 s) and operating voltage (0–30 %) can be set individually.	
Stall prevention	Responses threshold 0–220 %, user adjustable, also via analog input		
Torque limit level	Torque limit value can be set (0 to 400% variable)		
Control signals for operation	Frequency setting values	Analog input	Terminal 2, 4: 0 to 5 V DC, 0 to 10 V DC, 0/4 to 20 mA Terminal 1: –5 to +5V DC, –10 to +10 V DC
		Digital input	Four-digit BCD or 16-bit binary using the setting dial of the operation panel or parameter unit (when used with the option FR-A7AX)
	Start signal	Forward and reverse rotation or start signal automatic self-holding input (3-wire input) can be selected.	
	Input signals		You can select any twelve signals using Pr. 178 to Pr. 189 (input terminal function selection) from among multi speed selection, remote setting, stop-on-contact, second function selection, third function selection, terminal 4 input selection, JOG operation selection, selection of automatic restart after instantaneous power failure, flying start, external thermal relay input, inverter operation enable signal (FR-HC/FR-CV connection), FR-HC connection (instantaneous power failure detection), PU operation/external inter lock signal , external DC injection brake operation start, PID control enable terminal, brake opening completion signal, PU operation/external operation switchover, load pattern selection forward rotation reverse rotation boost, V/F switching, load torque high-speed frequency, S-pattern acceleration/deceleration C switchover, pre-excitation, output stop, start self-holding selection, control mode changing, torque limit selection, start-time tuning start external input, torque bias selection 1, 2 <sup>①</sup> , P/PI control switchover, traverse function selection, forward rotation command, reverse rotation command, inverter reset, PTC thermistor input, PID forward reverse operation switchover, PU-NET operation switchover, NET-external operation switchover, and command source switchover, conditional position pulse train sign <sup>①</sup> , conditional position droop pulse clear <sup>①</sup>
		Pulse train input	100 kpps
Operational functions	Maximum/minimum frequency setting, frequency jump operation, external thermal relay input selection, polarity reversible operation, automatic restart after instantaneous power failure operation, electronic bypass operation, forward/reverse rotation prevention, remote setting, brake sequence, second function, third function, multi-speed operation, multi-speed operation, original operation continuation at instantaneous power failure, stop-on-contact control, load torque high speed frequency control, droop control, regeneration avoidance, slip compensation, operation mode selection, offline auto tuning function, online auto tuning function, PID control, computer link operation (RS-485), motor end orientation <sup>①</sup> , machine end orientation <sup>①</sup> , pre-excitation, notch filter, machine analyzer <sup>①</sup> , easy gain tuning, speed feed forward, and torque bias <sup>①</sup>		

**Tab. A-3:** Common specifications

FR-A740		Specification
Control signals for operation	Output signals	Operating status You can select any signals using Pr. 190 to Pr. 196 (output terminal function selection) from among inverter running, up-to-frequency, instantaneous power failure/undervoltage, overload warning, output frequency (speed) detection, second output frequency (speed) detection, third output frequency (speed) detection, regenerative brake prealarm, electronic thermal relay function pre-alarm, PU operation mode, inverter operation ready, output current detection, zero current detection, PID lower limit, PID upper limit, PID forward rotation reverse rotation output, electronic bypass MC1, electronic bypass MC2, electronic bypass MC3, orientation completion <sup>①</sup> , brake opening request, fan fault output, heatsink overheat pre-alarm, inverter running/start command on, deceleration at an instantaneous power failure, PID control activated, during retry, PID output interruption, life alarm, alarm output 1, 2, 3 (power-off signal), power savings average value update timing, current average monitor, maintenance timer alarm, remote output, forward rotation output <sup>①</sup> , reverse rotation output <sup>①</sup> , low speed output, torque detection, regenerative status output <sup>①</sup> , start-time tuning completion, in-position completion <sup>①</sup> , minor failure output and alarm output. Open collector output (5 points), relay output (2 points) and alarm code of the inverter can be output (4 bit) from the open collector
		When using the FR-A7AY, FR-A7AR options You can select any seven signals using Pr. 313 to Pr. 319 (extension output terminal function selection) from among control circuit capacitor life, main circuit capacitor life, cooling fan life, inrush current limit circuit life (Only positive logic can be set for extension terminals of the FR-A7AR)
		Pulse/analog output You can select any signals using Pr. 54 "FM terminal function selection (pulse train output)" and Pr. 158 "AM terminal function selection (analog output)" from among output frequency, motor current (steady or peak value), output voltage, frequency setting, operation speed, motor torque, converter output voltage (steady or peak value), electronic thermal relay function load factor, input power, output power, load meter, motor excitation current, cumulative energization time, actual operation time, motor load factor, cumulative power, energy saving effect, cumulative saving power, regenerative brake duty, PID set point, PID measured value, PID deviation, inverter I/O terminal monitor, input terminal option monitor (FR-DU07 only), output terminal option monitor (FR-DU07 only), option fitting status (FR-PU07/FR-PU04 only), terminal assignment status (FR-PU07/FR-PU04 only), torque command, torque current command, feed back pulse <sup>①</sup> , motor output
Display	Control unit display (FR-DU07/FR-PU07/FR-PU04)	Operating status Output frequency, motor current (steady or peak value), output voltage, frequency setting, running speed, motor torque, overload, converter output voltage (steady or peak value), electronic thermal relay function load factor, input power, output power, load meter, motor excitation current, cumulative energization time, actual operation time, motor load factor, cumulative power, energy saving effect, cumulative saving power, regenerative brake duty, PID set point, PID measured value, PID deviation, inverter I/O terminal monitor, input terminal option monitor (FR-DU07 only), output terminal option monitor (FR-DU07 only), option fitting status (FR-PU07/FR-PU04 only), terminal assignment status (FR-PU07/FR-PU04 only), torque command, torque current command, feed back pulse <sup>①</sup> , motor output
		Alarm definition Alarm definition is displayed when the protective function is activated, the output voltage/current/frequency/cumulative energizing time right before the protection function was activated and the past 8 alarm definitions are stored.
		Interactive guidance Operation guide/trouble shooting with a help function (FR-PU07/FR-PU04 only)
Protection	Protective functions	Overcurrent during acceleration, overcurrent during constant speed, overcurrent during deceleration, overvoltage during acceleration, overvoltage during constant speed, overvoltage during deceleration, inverter protection thermal operation, motor protection thermal operation, heatsink overheat, instantaneous power failure occurrence, undervoltage, input phase failure, motor overload, output side earth (ground) fault overcurrent, output short circuit, main circuit element overheat, output phase failure, external thermal relay operation, PTC thermistor operation, option alarm, parameter error, PU disconnection, retry count excess, CPU alarm, operation panel power supply short circuit, 24VDC power output short circuit, output current detection value excess, inrush current limit circuit alarm, communication alarm (inverter), USB error, opposite rotation deceleration error, analog input error, fan fault, overcurrent stall prevention, overvoltage stall prevention, regenerative brake prealarm, electronic thermal relay function prealarm, PU stop, maintenance timer alarm (FR-DU07 only), brake transistor alarm, parameter write error, copy operation error, operation panel lock, parameter copy alarm, speed limit indication, encoder no-signal <sup>①</sup> , speed deviation large <sup>①</sup> , overspeed <sup>①</sup> , position error large <sup>①</sup> , encoder phase error <sup>①</sup>
Environment	Ambient temperature	-10 °C to +50 °C (non-freezing) For selection of the load characteristics with a 120% overload rating the max. temperature is 40°C
	Storage temperature <sup>②</sup>	-20 °C to +65 °C
	Ambient humidity	Max. 90 % RH (non-condensing)
	Ambience conditions	For indoor use only, avoid environments containing corrosive gases, install in a dust-free location.
	Altitude	Maximum 1000m above sea level for standard operation. After that derate by 3% for every extra 500 m up to 2500 m (92%)
	Vibration resistance	5.9 m/s <sup>2</sup> or less (JIS 60068-2-6) <sup>③</sup>

**Tab. A-3:** Common specifications

- ① Available only when the option FR-A7AP is mounted.
- ② The product may only be exposed to the full extremes of this temperature range for short periods (e.g. during transportation).
- ③ 2.9 m/s<sup>2</sup> or less for the 04320 or more.



## A.4 Outline dimension drawings

### A.4.1 FR-A740-00023 to -00126

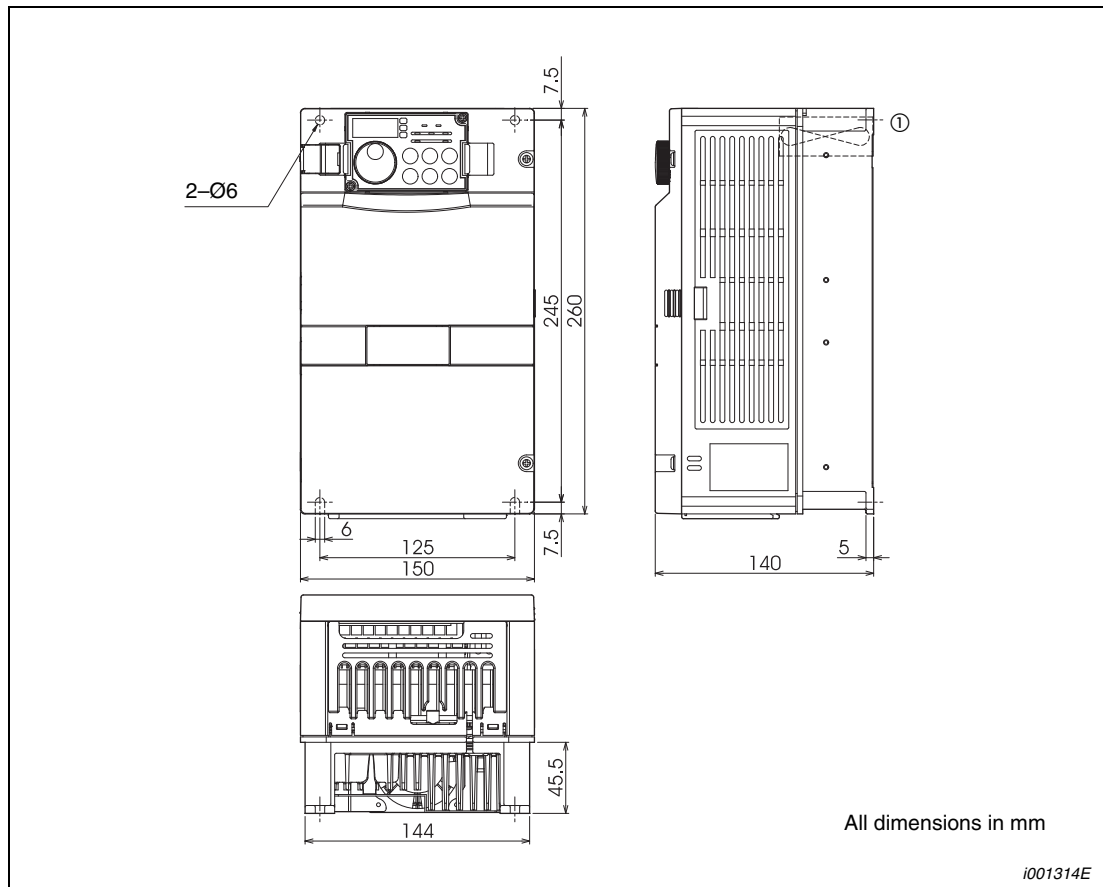

**Fig. A-1:** Dimensions FR-A740-00023 to -00126

① The FR-A740-00023 to 00052 are not provided with a cooling fan.

**A.4.2 FR-A740-00170 to -00380**

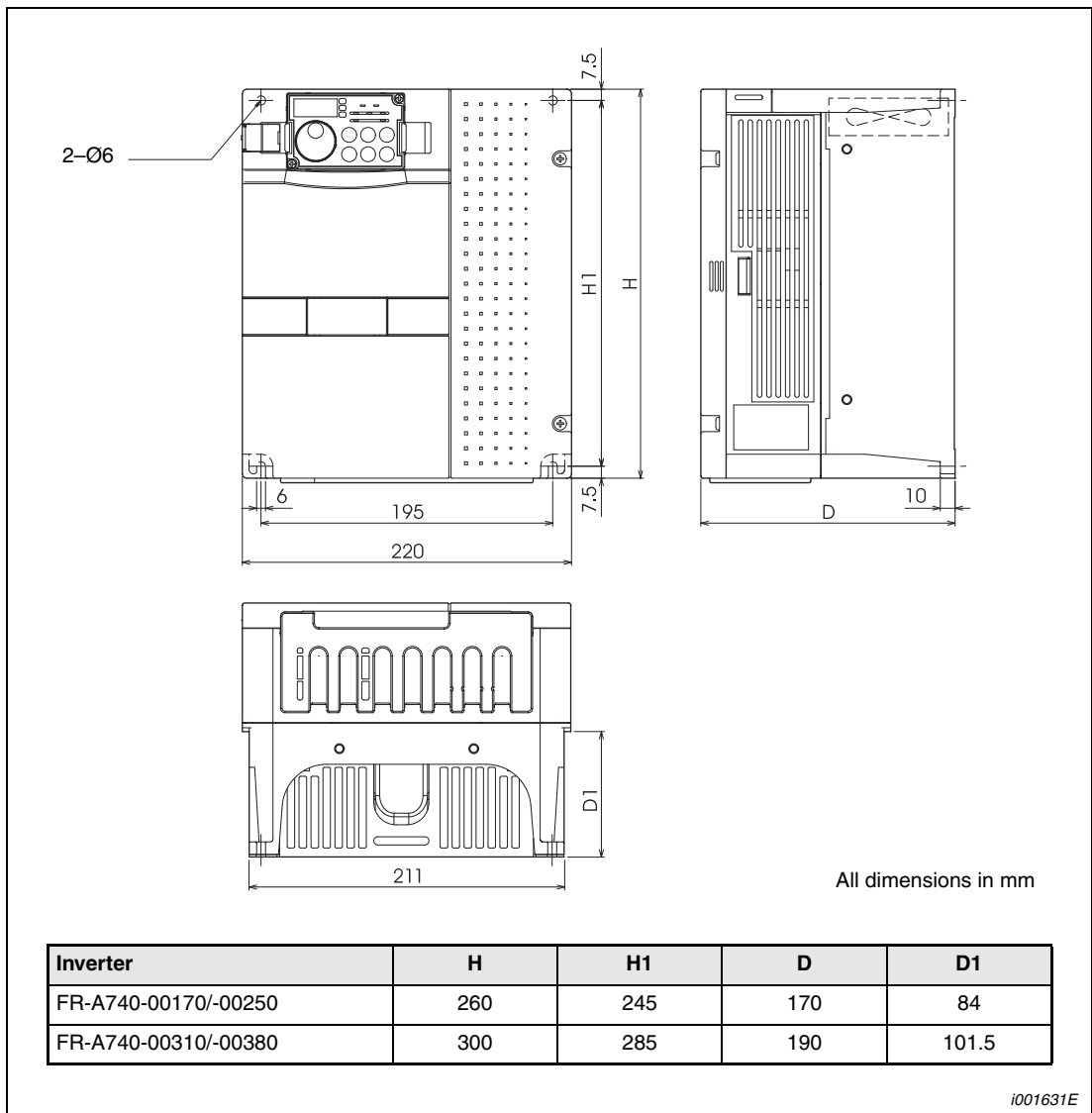

**Fig. A-2:** Dimensions FR-A740-00170 to -00380

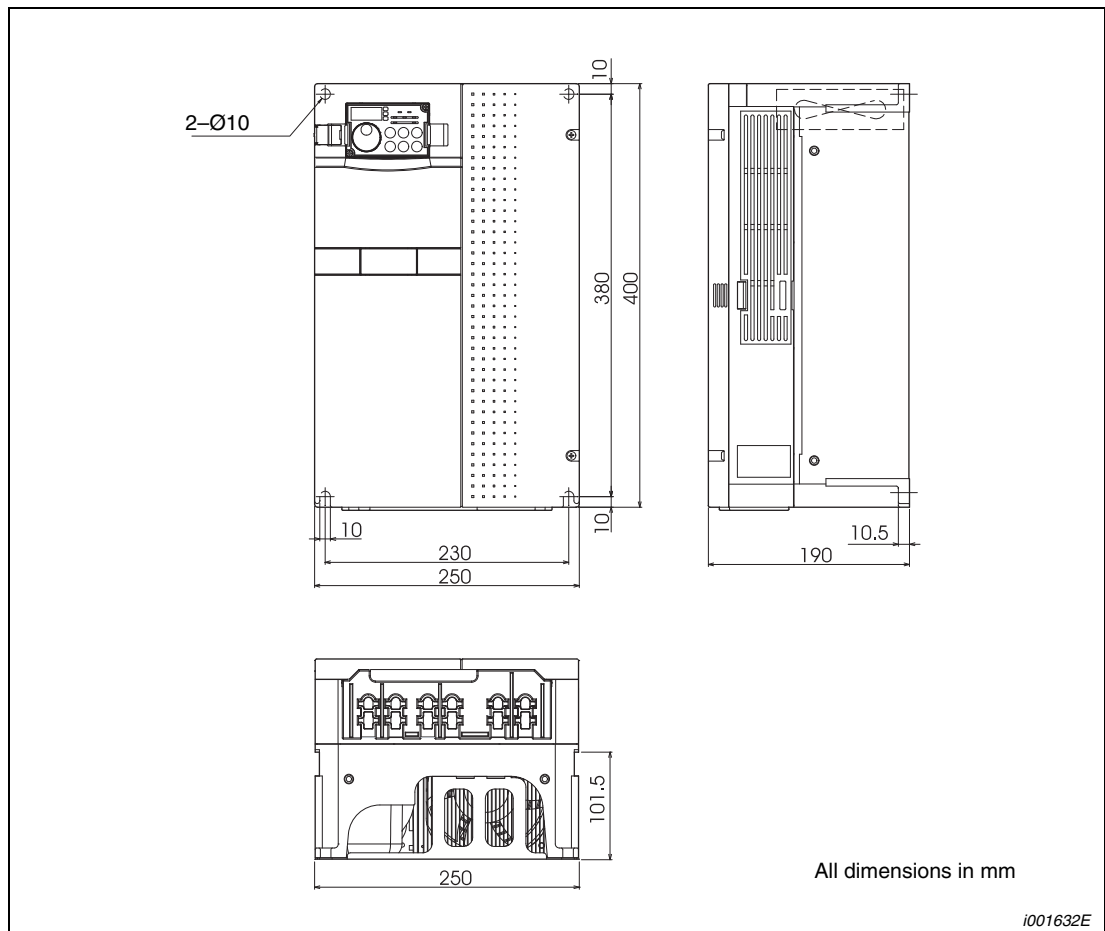
**A.4.3 FR-A740-00470 and -00620****Fig. A-3:** Dimensions FR-A740-00470 and -00620

**A.4.4 FR-A740-00770 to -01160**

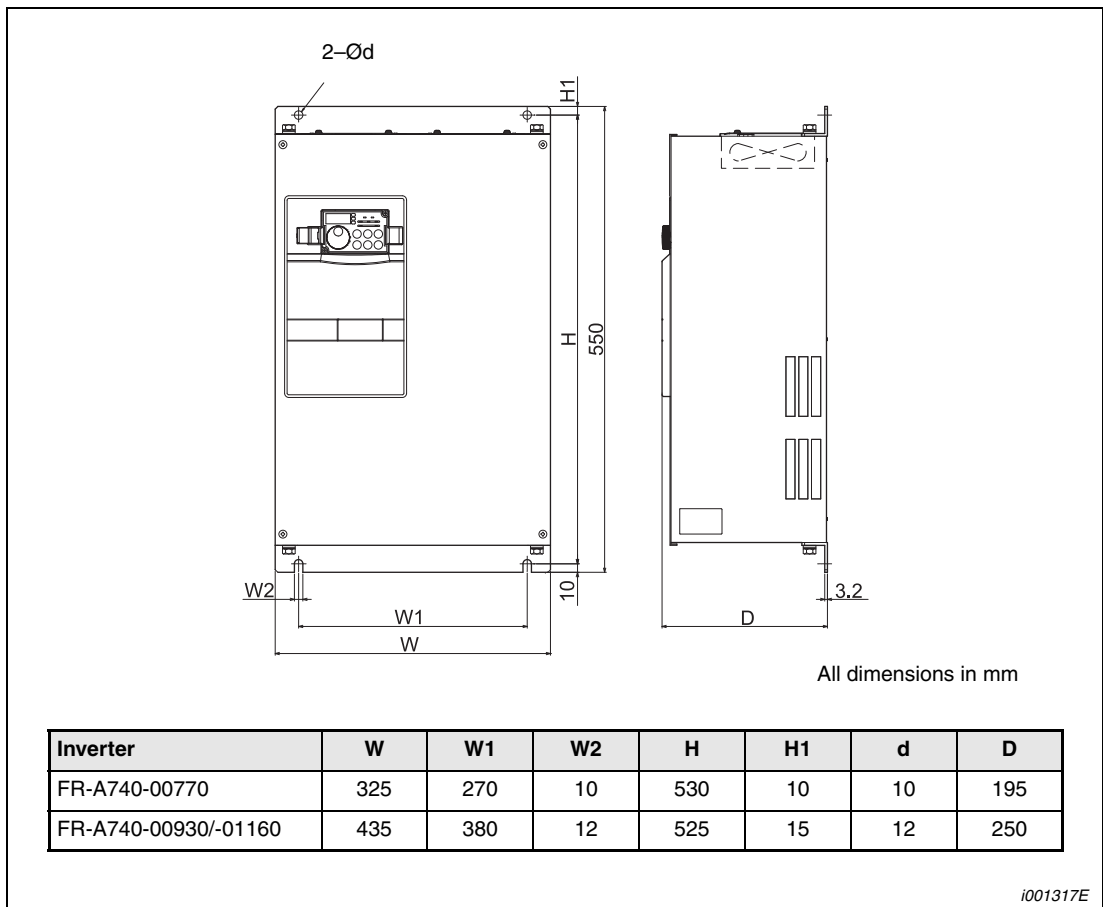

**Fig. A-4:** Dimensions FR-A740-00770 to -01160

### A.4.5 FR-A740-01800

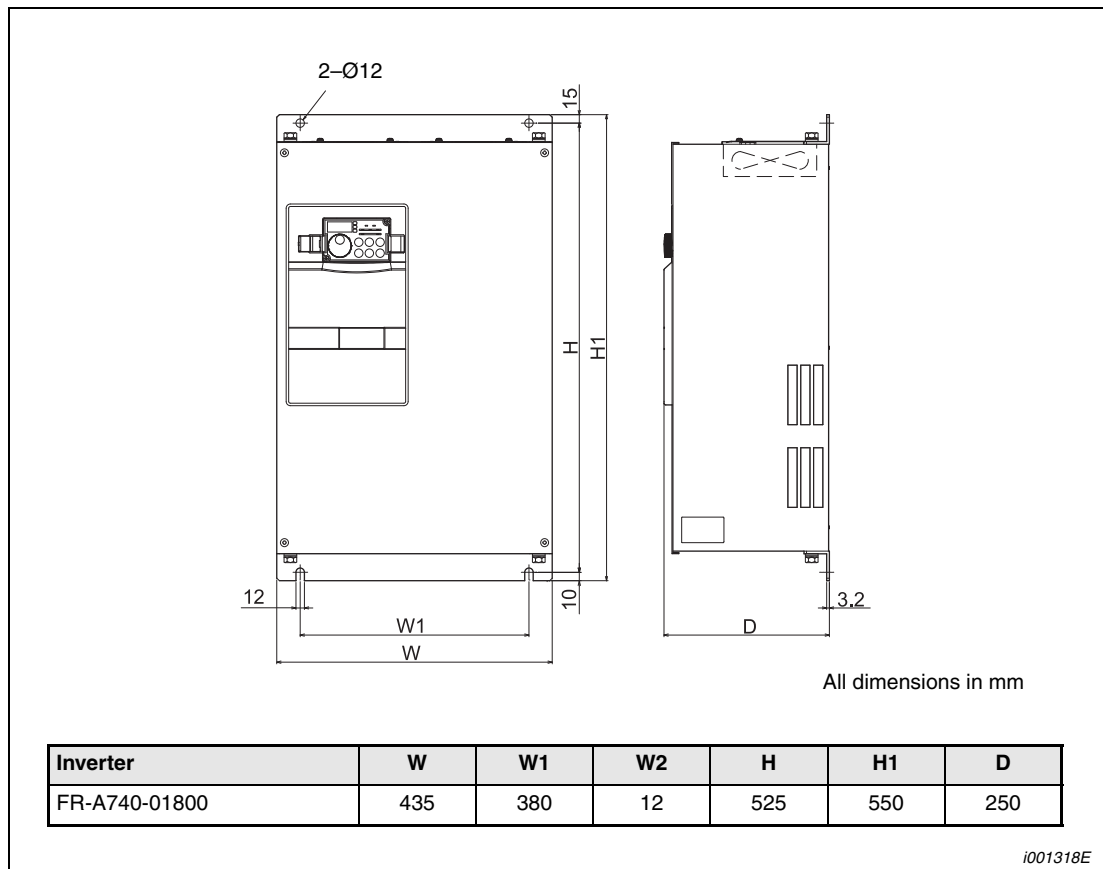

**Fig. A-5:** Dimensions FR-A740-01800

**A.4.6 FR-A740-02160 and -02600**

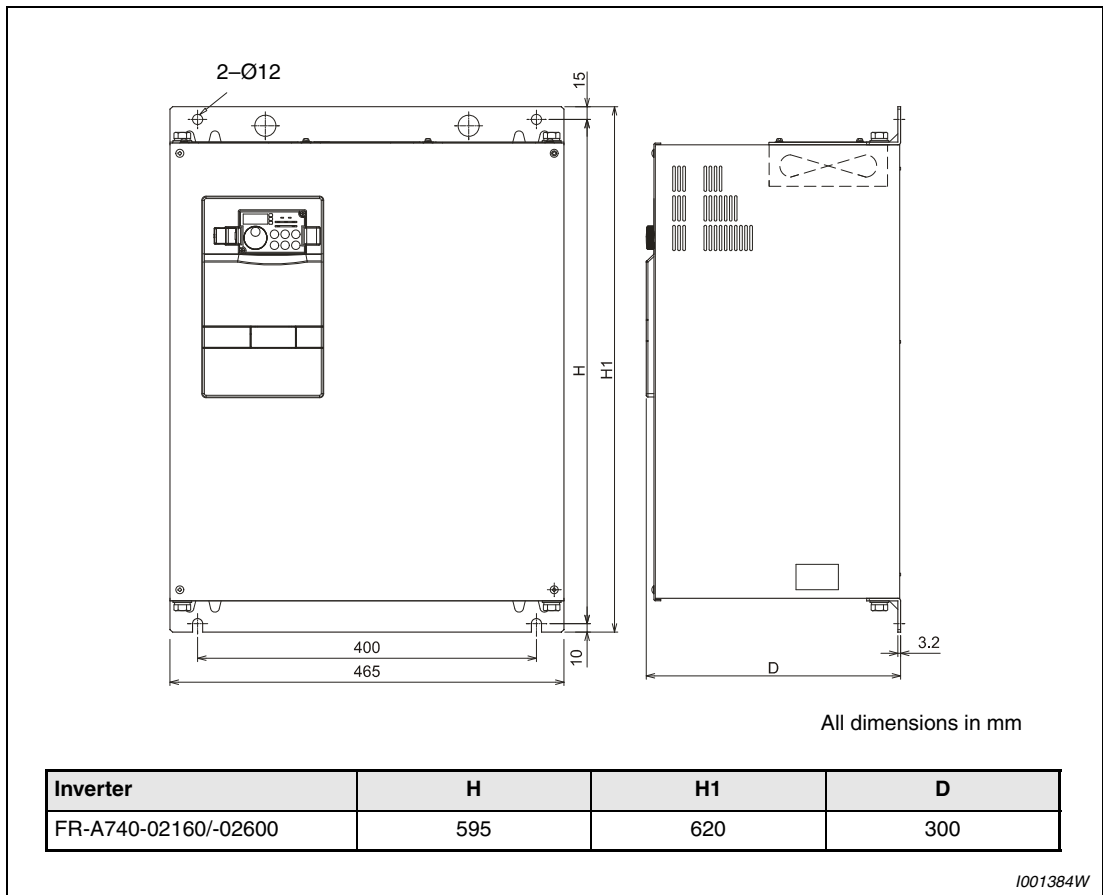

**Fig. A-6:** Dimensions of FR-A740-02160 and FR-A740-02600

**A.4.7 FR-A740-03250 and -3610**

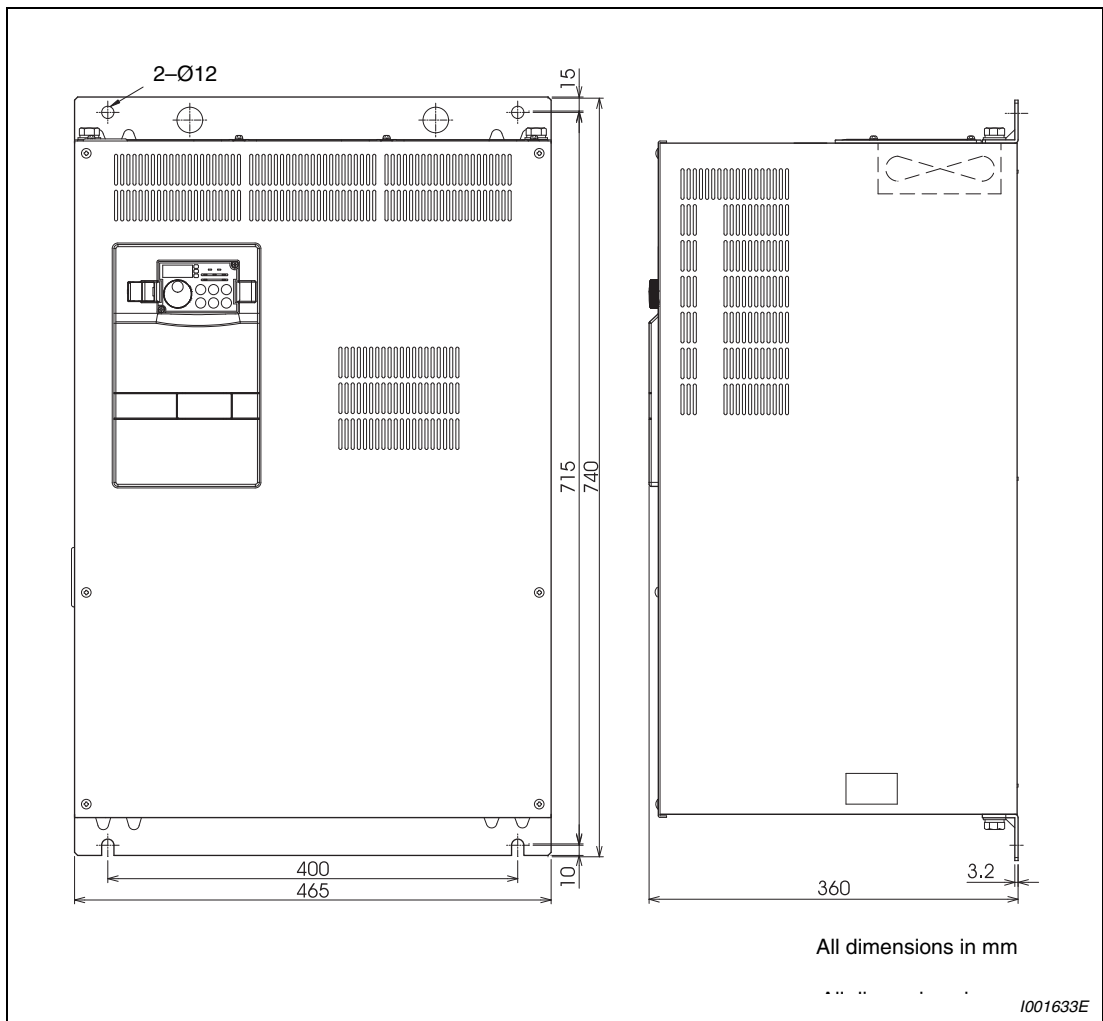

**Fig. A-7:** Dimensions of FR-A740-03250 and -03610

**A.4.8 FR-A740-04320 and -04810**

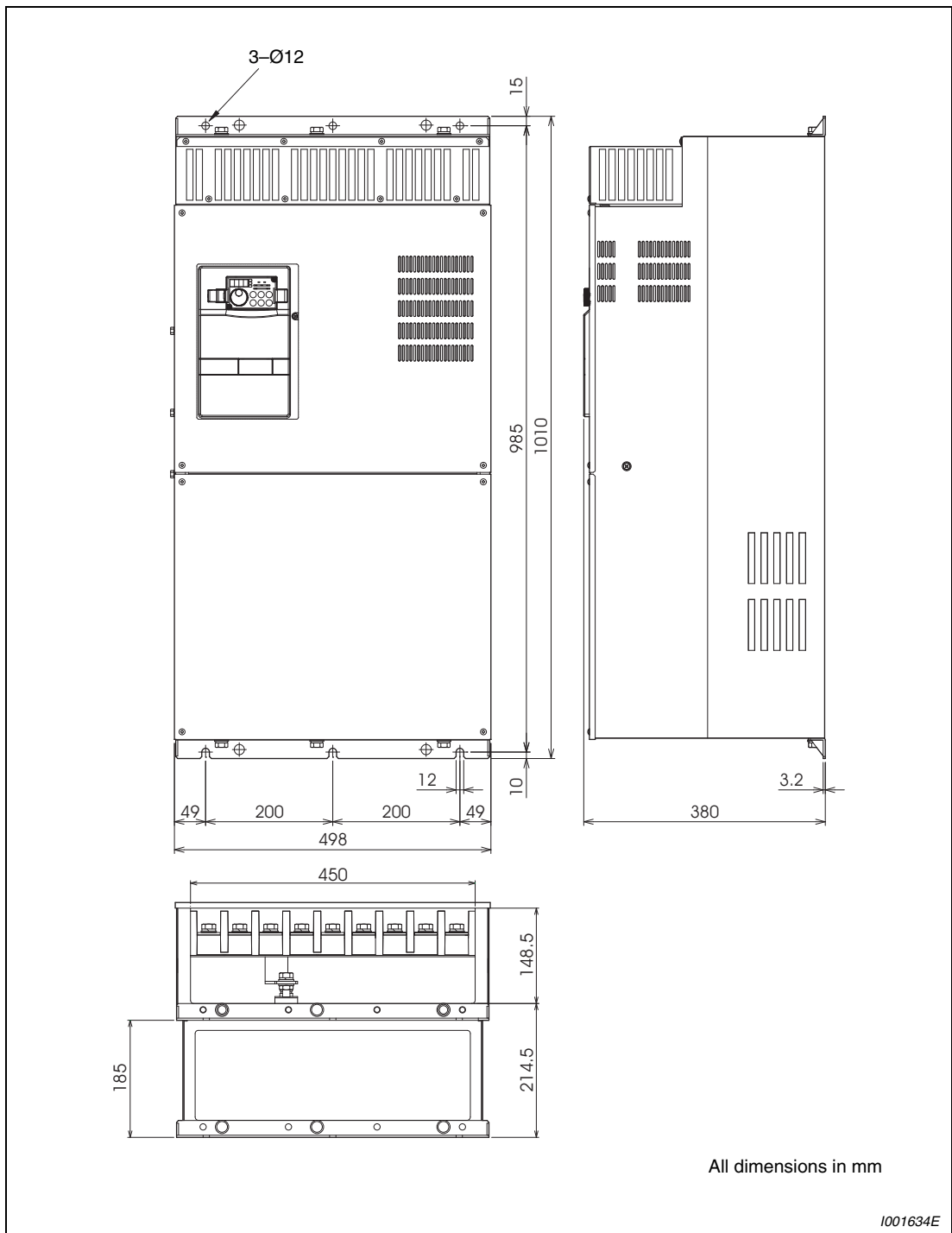

**Fig. A-8:** Dimensions of FR-A740-04320 and -04810



**A.4.9 FR-A740-05470, -06100 and -06830**

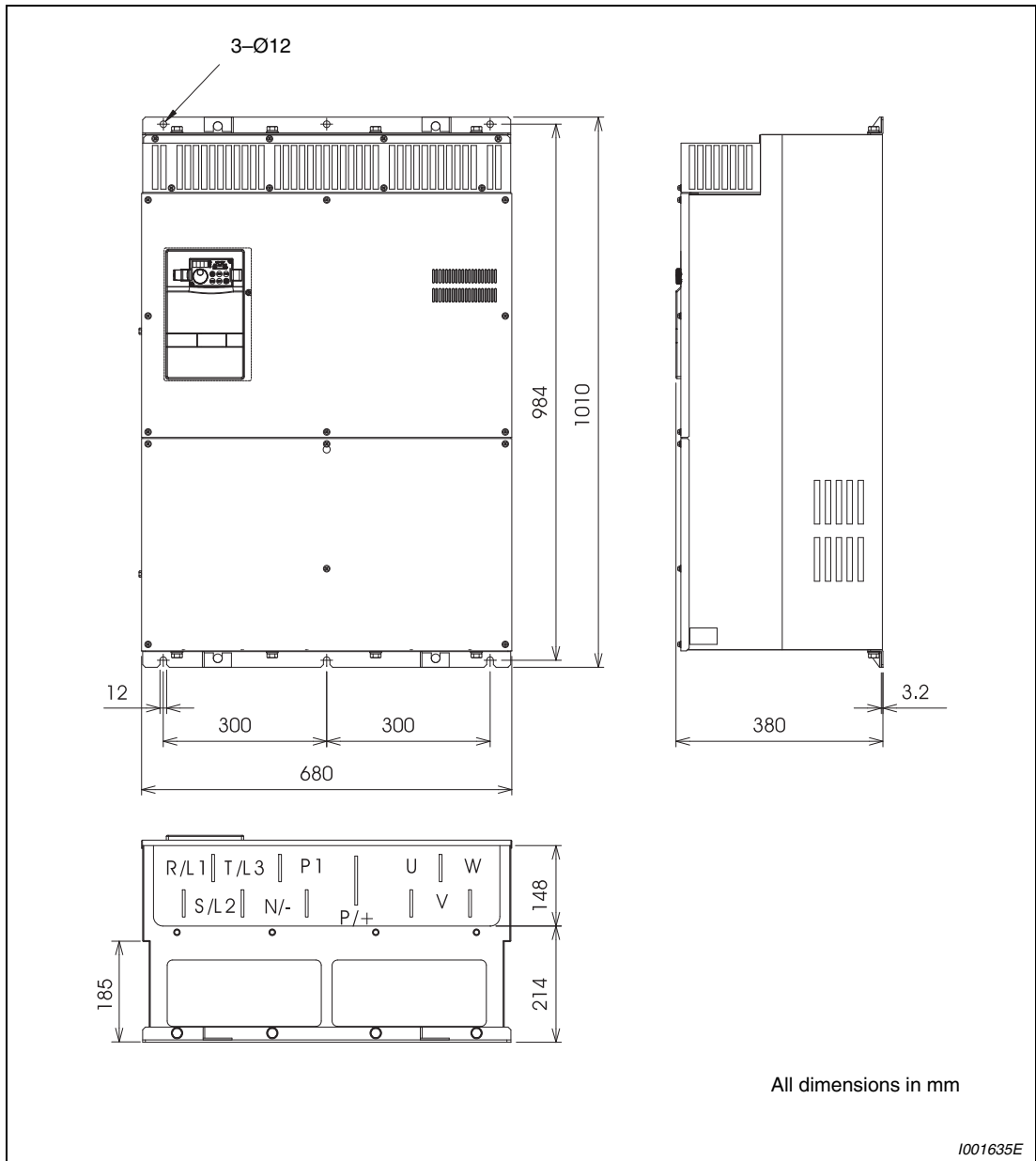

**Fig. A-9:** Dimensions of FR-A740-05470, FR-A740-006100 and FR-A740-06830

**A.4.10 FR-A740-07700 and -08660**

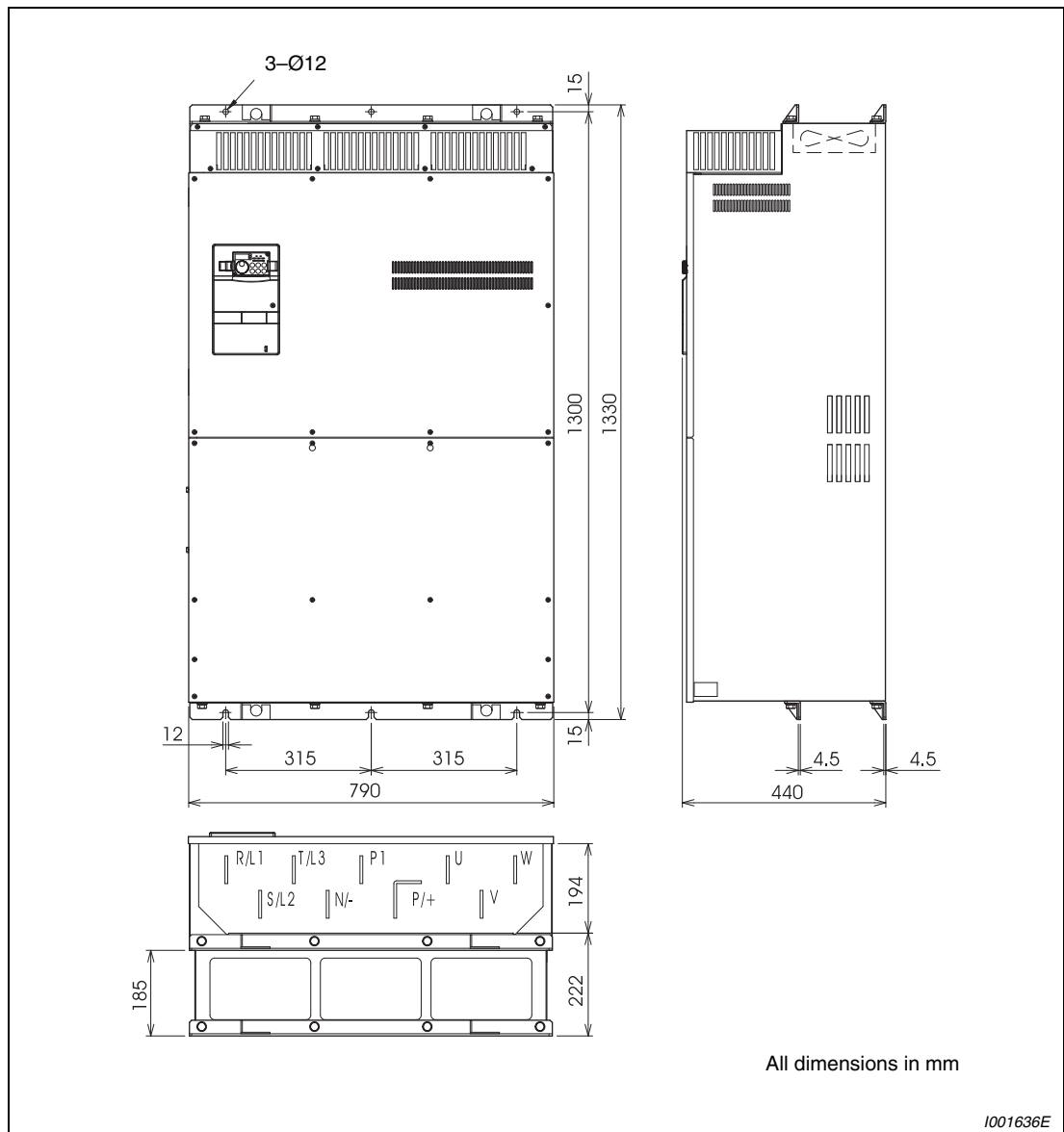

**Fig. A-10:** Dimensions of FR-A740-07700 and FR-A740-08660

**A.4.11 FR-A740-09620, -10940 and -12120**

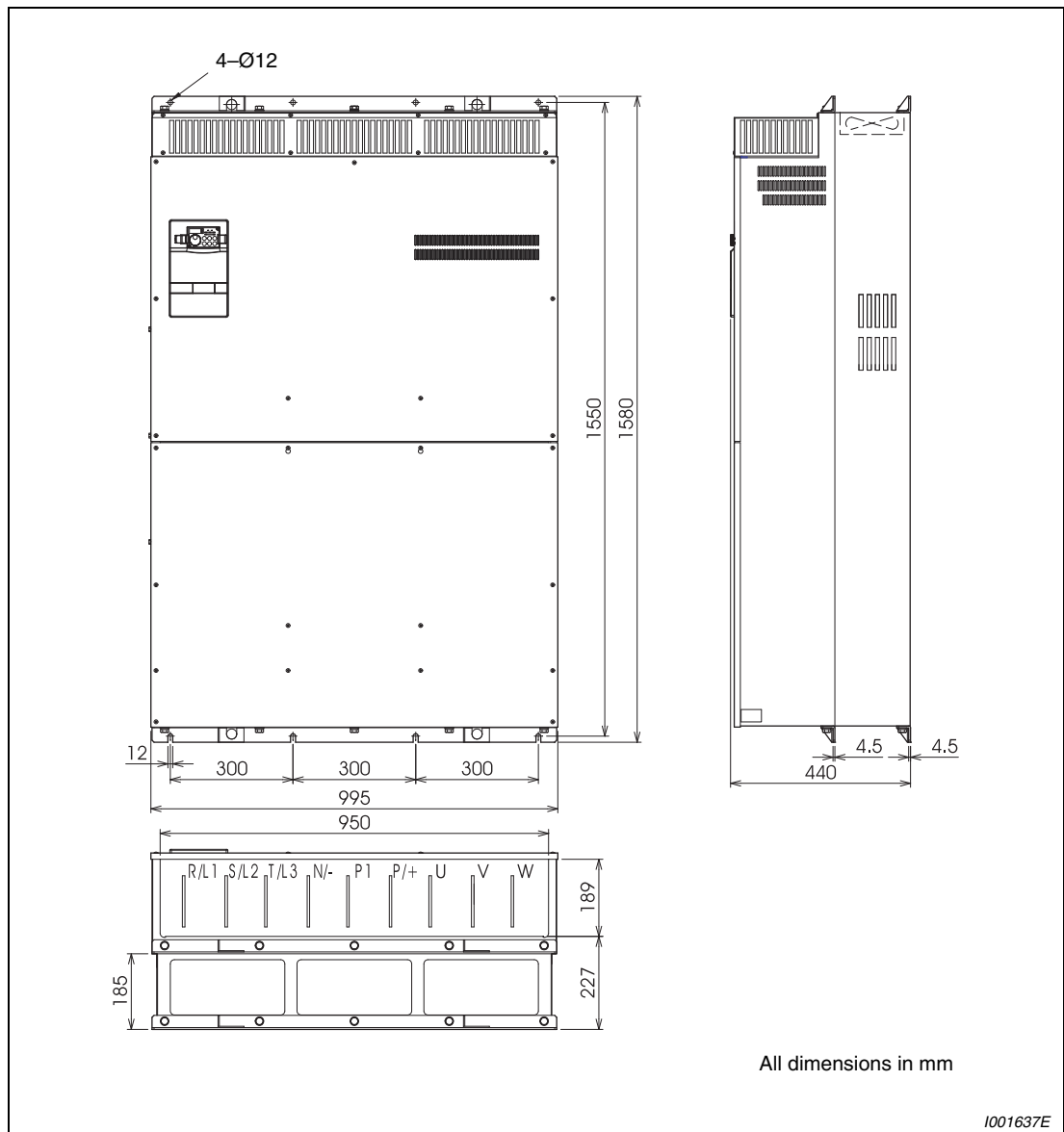

**Fig. A-11:** Dimensions of FR-A740-09620, FR-A740-10940 and FR-A740-12120

**A.4.12 DC reactors**

**FR-HEL-H90K**

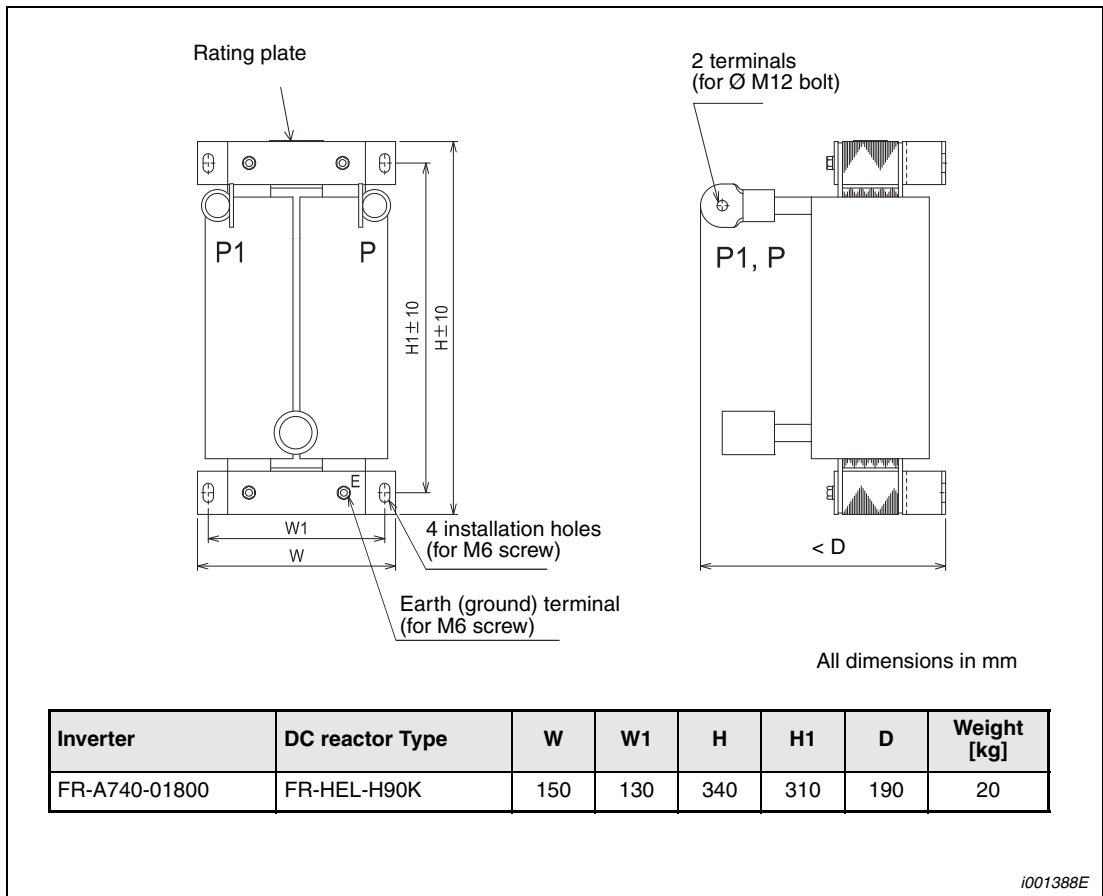

**Fig. A-12: DC reactor FR-HEL-H90K**

**FR-HEL-H110K to -H185K**

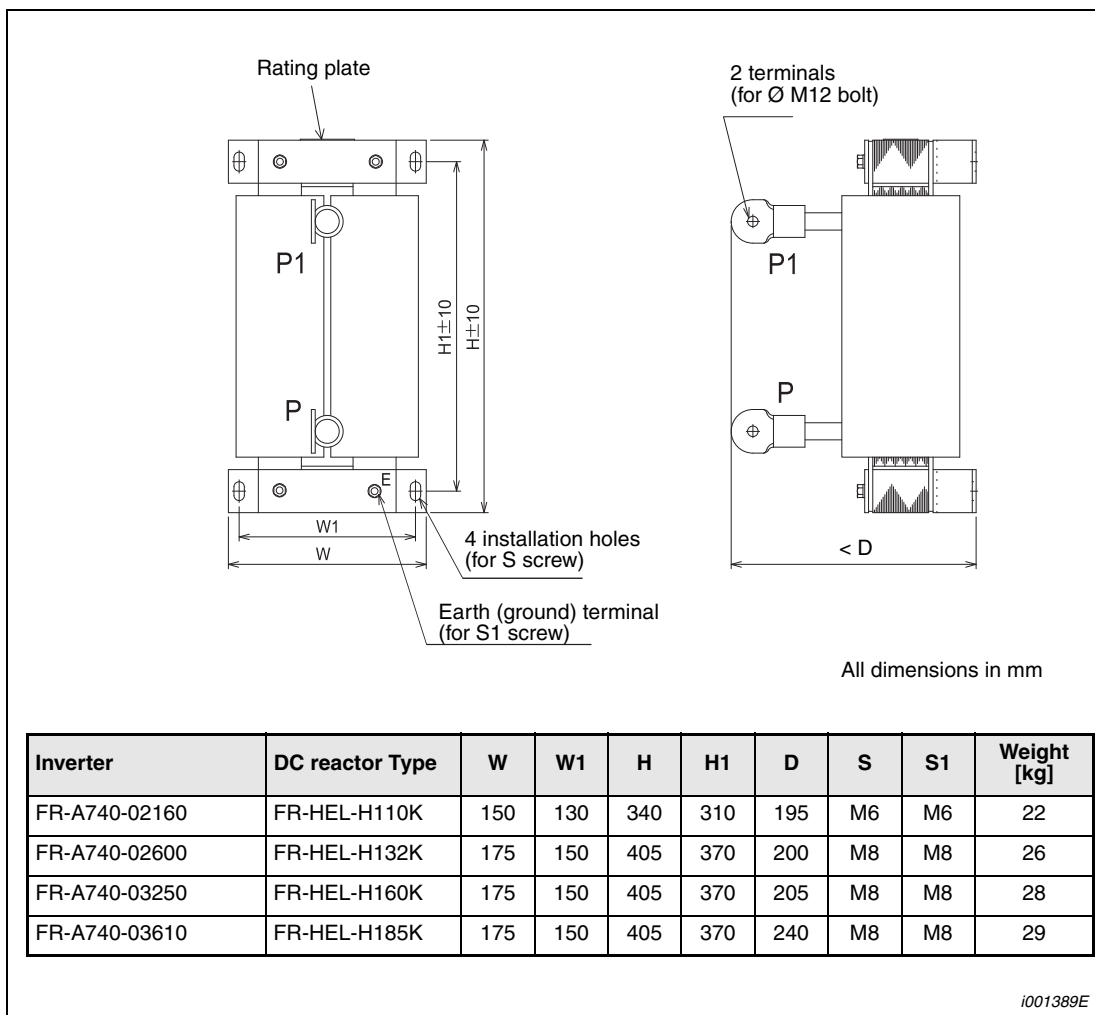

**Fig. A-13:** DC reactors FR-HEL-H110K to -H185K

**FR-HEL-H220K to -H355K**

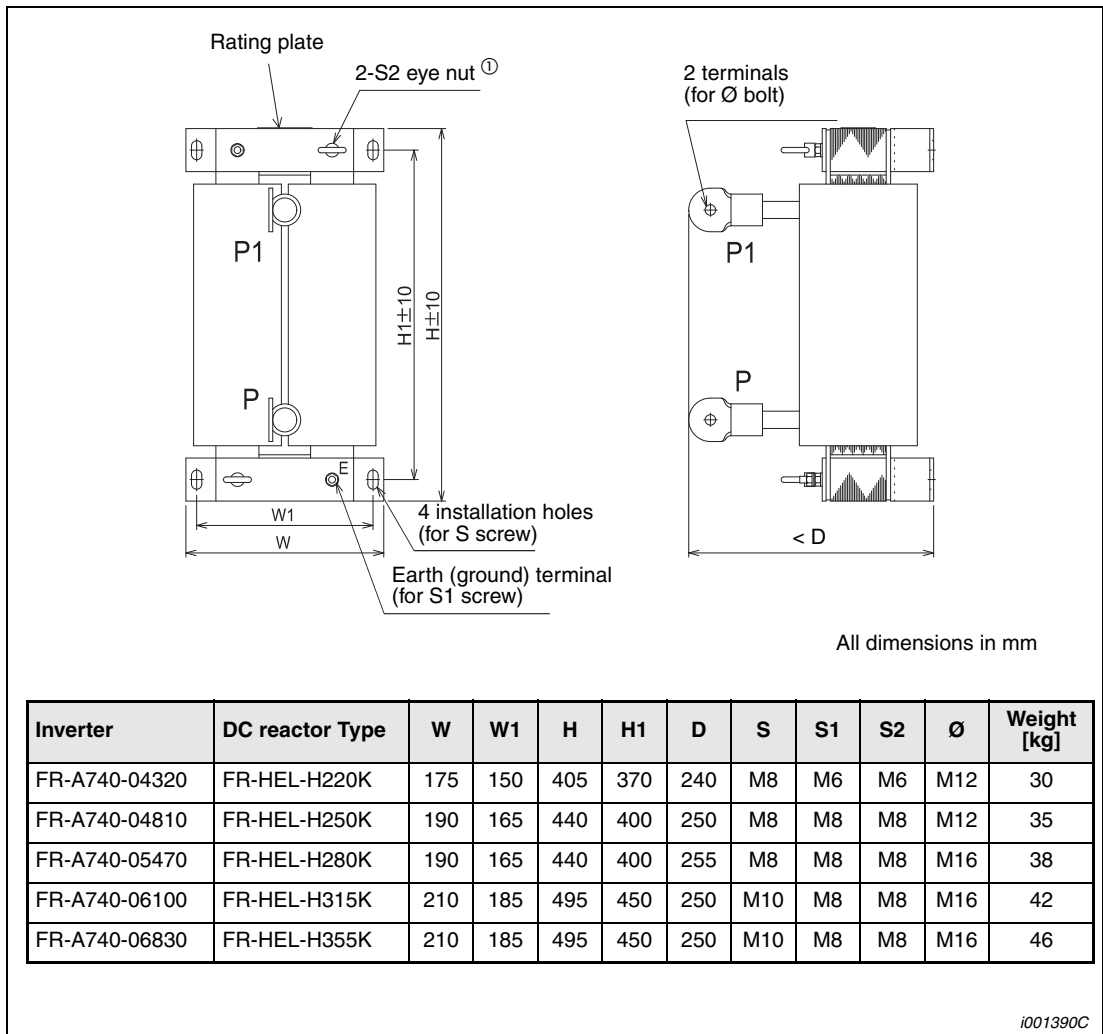

**Fig. A-14:** DC reactors FR-HEL-H220K to -H355K

① Remove the eye nut after installation of the product.

## FR-HEL-H400K and -H450K

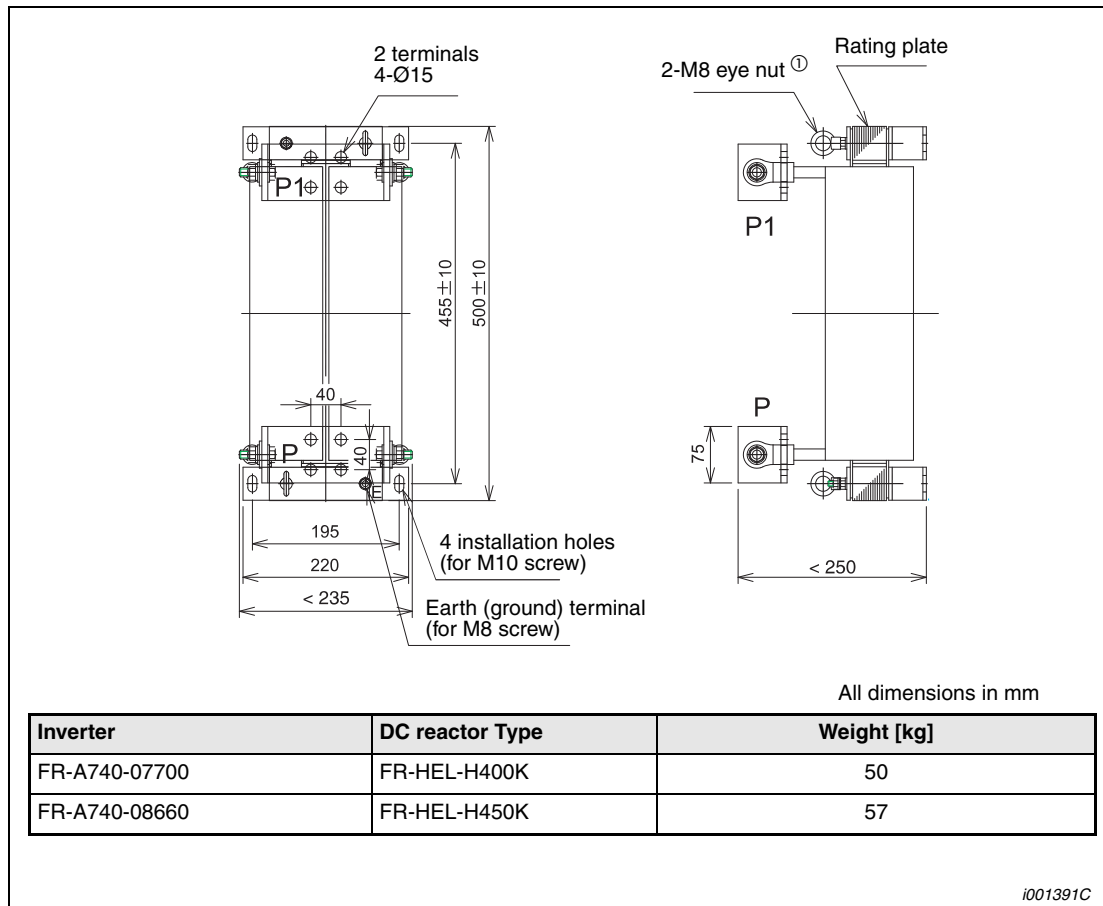

**Fig. A-15:** DC reactors FR-HEL-H400K and -H450K

① Remove the eye nut after installation of the product.

**FR-HEL-H500K to -H630K**

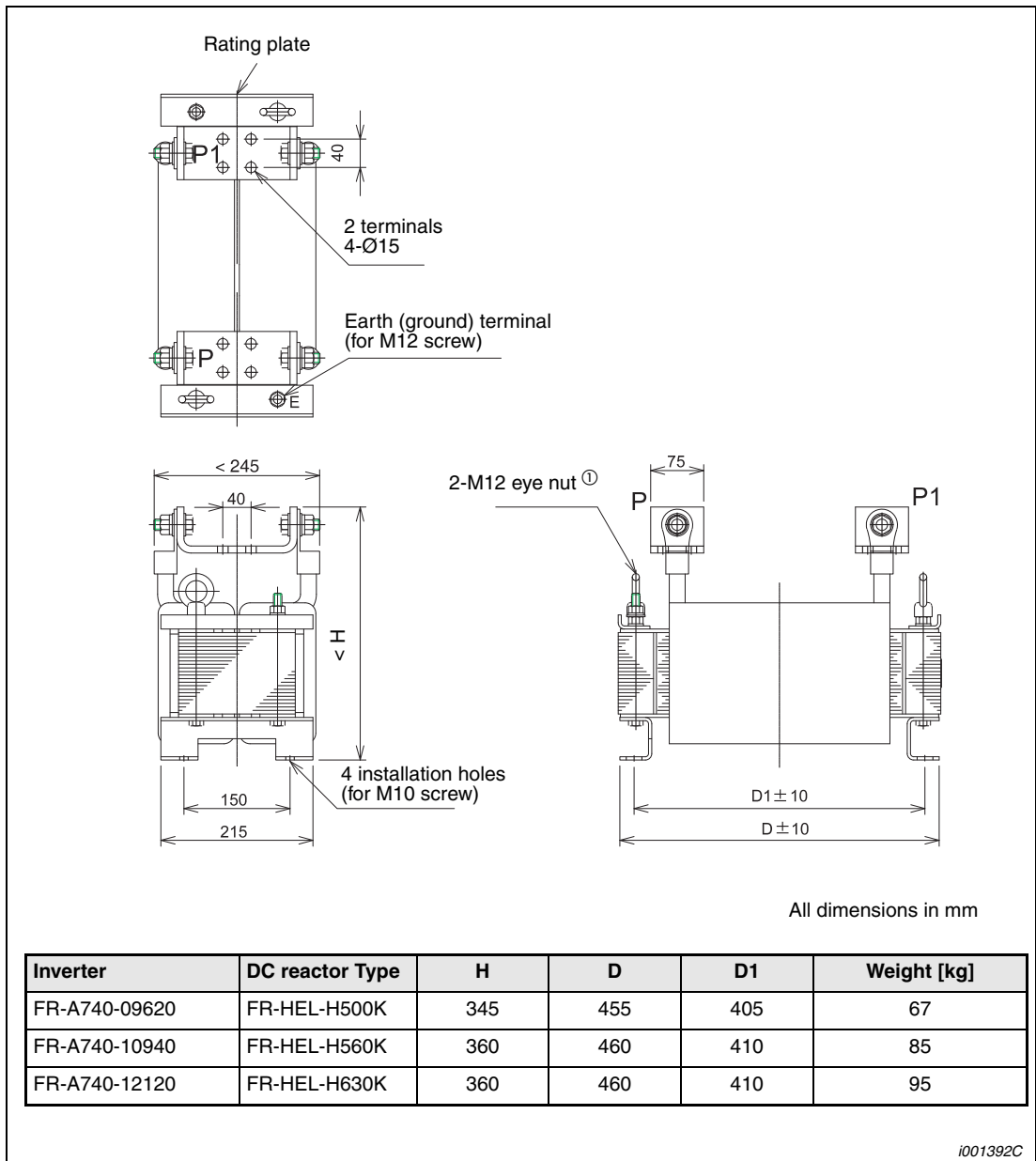

**Fig. A-16:** DC reactors FR-HEL-H500K to -H630K

① Remove the eye nut after installation of the product.



### A.4.13 Panel cutting for the heatsink protrusion attachment

Cut the panel of the enclosure according to the inverter capacity.

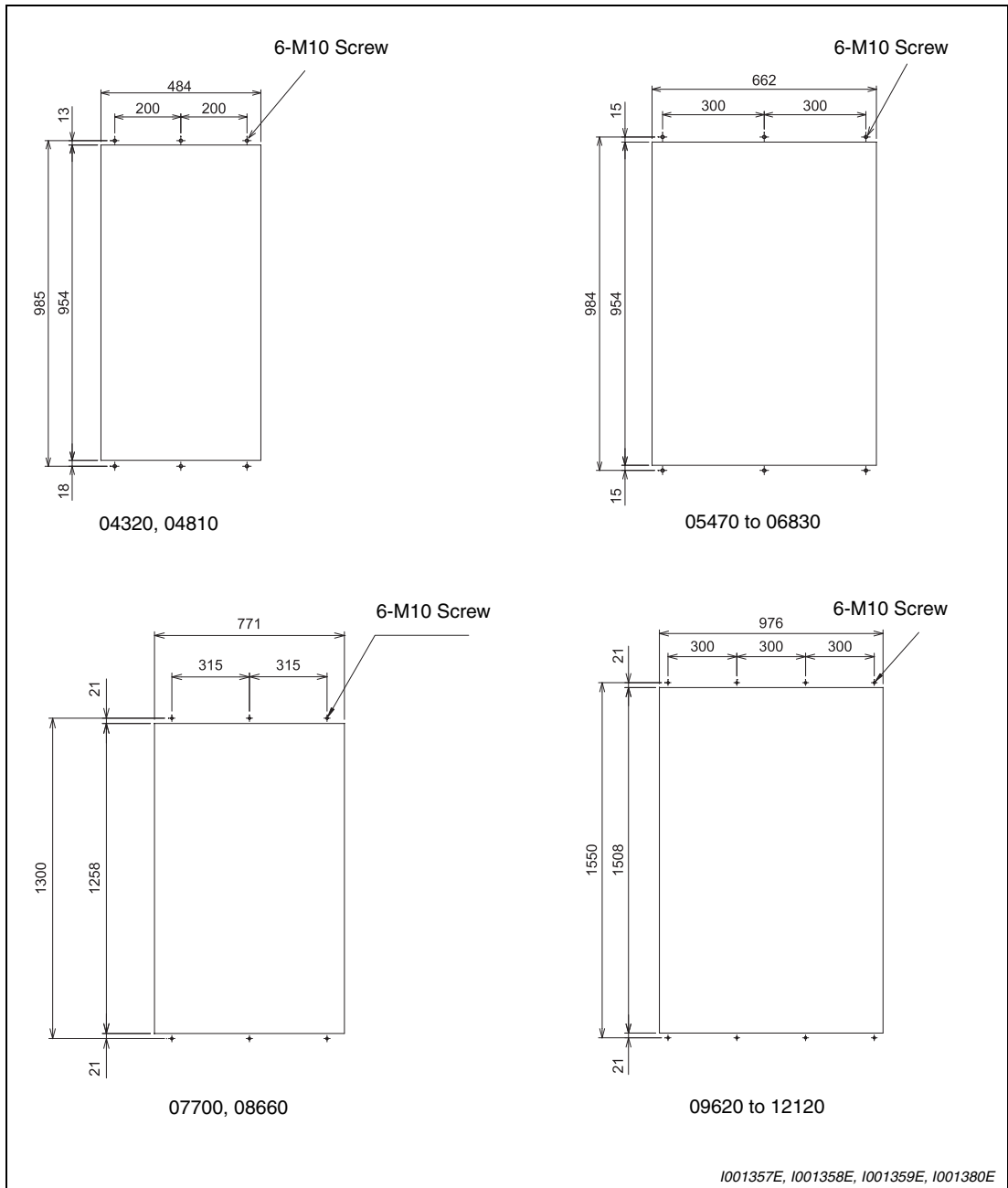

**Fig. A-17: Panel cutting**

**A.4.14 Operation panel FR-DU07**

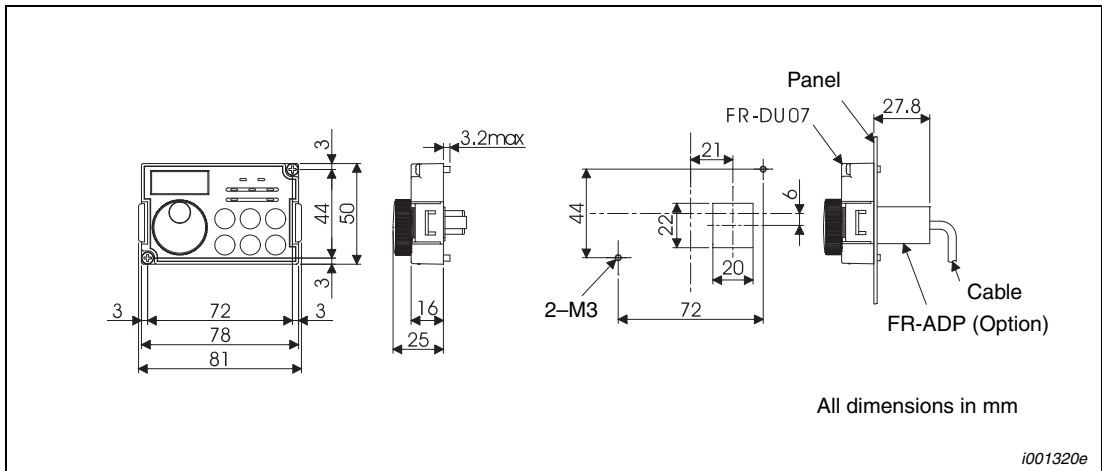

**Fig. A-18: Operation panel FR-DU07**

**A.4.15 Operation panel FR-PU07**

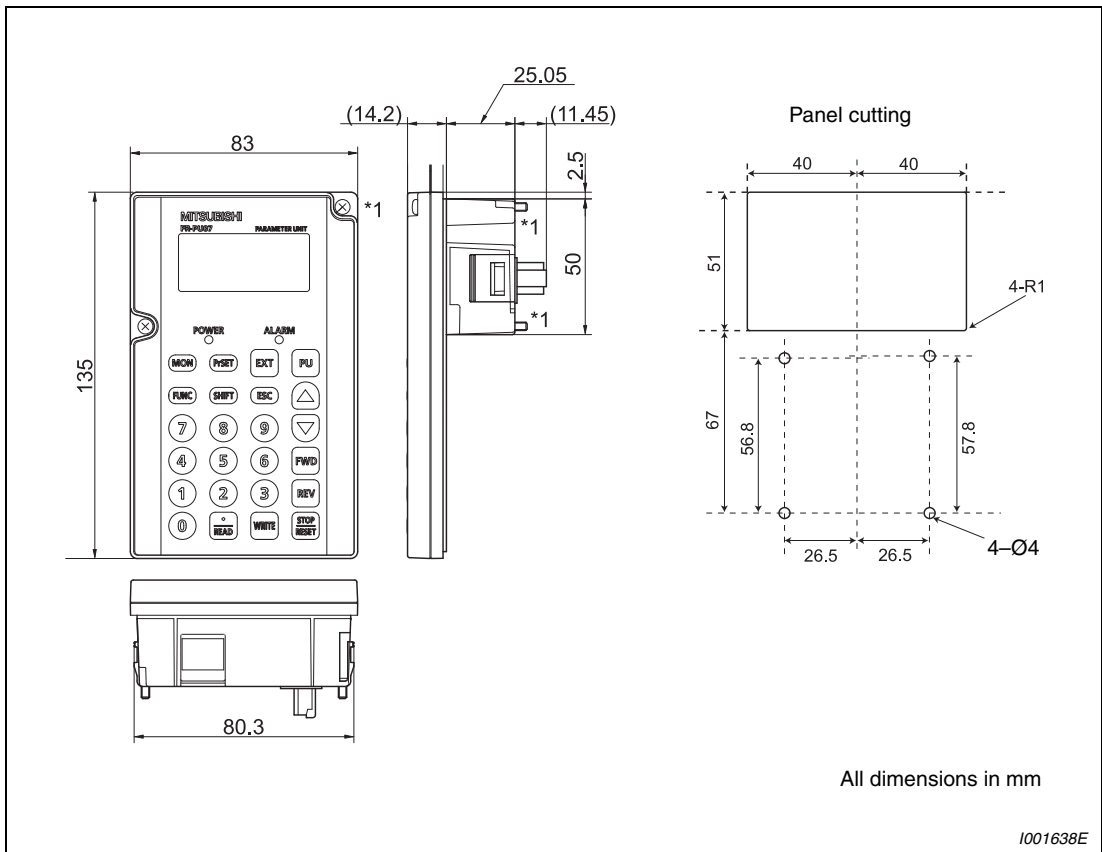

**Fig. A-19: Parameter unit FR-PU07**

- NOTES**
- When installing the FR-PU07 on the enclosure, etc., remove screws for fixing the FR-PU07 to the inverter or fix the screws to the FR-PU07 with M3 nuts.
  - Select installation screws whose length will not exceed the effective depth of the installation screws threads (5 mm).

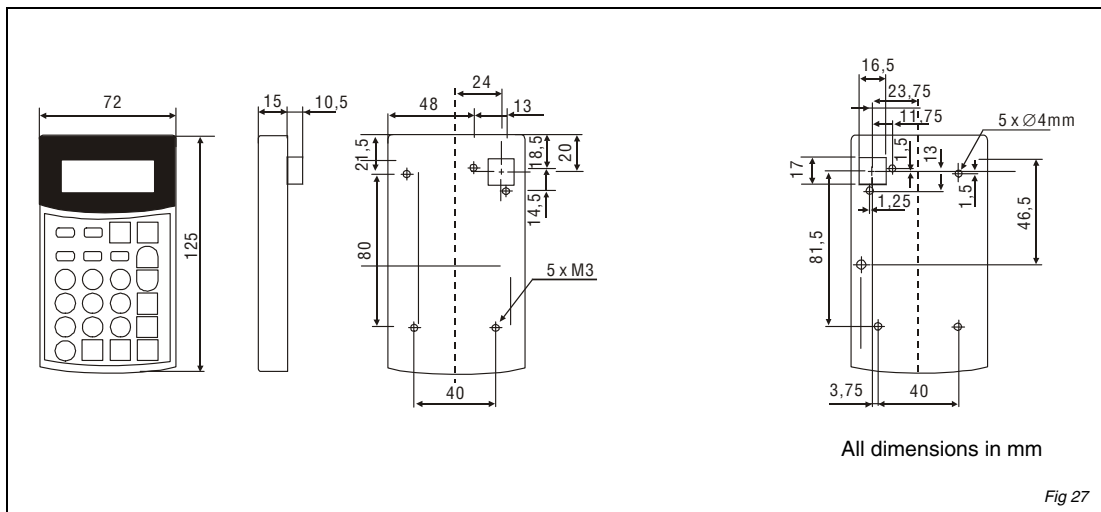
**A.4.16 Parameter unit FR-PU04****Fig. A-20:** Parameter unit FR-PU04

## A.5 Parameter list with instruction codes

In the initial setting, only the simple mode parameters are displayed.  
Set Pr. 160 "User group read selection" as required.

Parameter	Name	Initial Value	Setting Range	Remarks
160	User group read selection	9999	9999	Only the simple mode parameters can be displayed.
			0	Simple mode and extended mode parameters can be displayed.
			1	Only parameters registered in the user group can be displayed.

**Tab. A-4:** Settings of parameter 160

### NOTES

The parameters marked © are the simple mode parameters.

The parameters marked with  in the table allow its setting to be changed during operation even if "0" (initial value) is set in Pr. 77 "Parameter write selection".

Parameters for the option are displayed only when the option unit is installed.

The instruction codes (hexadecimal) for "read" and "write" on the right of the parameter number are those used to set the parameter via communication. "Extended" indicates the setting of the extended link parameter. (Refer to section 6.23 for communication.)

The symbols in the table have the following meanings:

✓: The parameter is usable in this mode

—: The parameter is not usable in this mode.

△: The parameter is available only during position control set by parameter 800.

Function	Parameter	Instruction Code			Name	Control Mode-based Correspondence Table							Refer to Page	Customer Setting	
		Read	Write	Extended		V/f Control	Advanced magnetic flux vector control	Vector control			Real sensorless vector control				
								Speed	Torque	Position	Speed	Torque			
Basic functions	© 0	00	80	0	Torque boost	✓	—	—	—	—	—	—	6-147		
	© 1	01	81	0	Maximum frequency	✓	✓	✓	✓	✓	✓	✓	6-168		
	© 2	02	82	0	Minimum frequency	✓	✓	✓	✓	—	✓	✓			
	© 3	03	83	0	Base frequency	✓	—	—	—	—	—	—	6-172		
	© 4	04	84	0	Multi-speed setting	RH	✓	✓	✓	✓	△	✓	✓	6-183	
	© 5	05	85	0		RM	✓	✓	✓	✓	△	✓	✓		
	© 6	06	86	0		RL	✓	✓	✓	✓	△	✓	✓		
	© 7	07	87	0	Acceleration time	✓	✓	✓	✓	✓	△	✓	✓	6-195	
	© 8	08	88	0	Deceleration time	✓	✓	✓	✓	✓	△	✓	✓		
© 9	09	89	0	Electronic thermal O/L relay	✓	✓	✓	✓	✓	✓	✓	✓	6-212		

**Tab. A-5:** Parameter list with instruction codes (1)

Function	Parameter	Instruction Code			Name	Control Mode-based Correspondence Table							Refer to Page	Customer Setting
		Read	Write	Extended		V/f Control	Advanced magnetic flux vector control	Vector control			Realsensorless vector control			
								Speed	Torque	Position	Speed	Torque		
DC injection brake	10	0A	8A	0	DC injection brake operation frequency	✓	✓	✓	✓	—	✓	✓	6-241	
	11	0B	8B	0	DC injection brake operation time	✓	✓	✓	✓	—	✓	✓		
	12	0C	8C	0	DC injection brake operation voltage	✓	✓	—	—	—	—	—		
—	13	0D	8D	0	Starting frequency	✓	✓	✓	✓	—	✓	✓	6-199	
—	14	0E	8E	0	Load pattern selection	✓	—	—	—	—	—	—	6-175	
Jog operation	15	0F	8F	0	Jog frequency	✓	✓	✓	✓	—	✓	✓	6-186	
	16	10	90	0	Jog acceleration/ deceleration time	✓	✓	✓	✓	—	✓	✓		
—	17	11	91	0	MRS input selection	✓	✓	✓	✓	✓	✓	✓	6-290	
—	18	12	92	0	High speed maximum frequency	✓	✓	—	—	—	—	—	6-168	
—	19	13	93	0	Base frequency voltage	✓	—	—	—	—	—	—	6-172	
Acceleration/ deceleration time	20	14	94	0	Acceleration/ deceleration reference frequency	✓	✓	✓	✓	Δ	✓	✓	6-195	
	21	15	95	0	Acceleration/ deceleration time increments	✓	✓	✓	✓	Δ	✓	✓		
Stall prevention	22	16	96	0	Stall prevention operation level	✓	✓	✓	—	✓	✓	—	6-155	
	23	17	97	0	Stall prevention operation level compensation factor at double speed	✓	✓	—	—	—	—	—		
Multi-speed setting	24 – 27	18 – 1B	98 – 9B	0	Multi-speed setting 4 speed to 7 speed	✓	✓	✓	✓	Δ	✓	✓	6-183	
—	28	1C	9C	0	Multi-speed input compensation selection	✓	✓	✓	✓	—	✓	✓	6-190	
—	29	1D	9D	0	Acceleration/ deceleration pattern selection	✓	✓	✓	✓	—	✓	✓	6-201	
—	30	1E	9E	0	Regenerative function selection	✓	✓	✓	✓	✓	✓	✓	6-247	
Frequency jump	31	1F	9F	0	Frequency jump 1A	✓	✓	✓	✓	—	✓	✓	6-170	
	32	20	A0	0	Frequency jump 1B	✓	✓	✓	✓	—	✓	✓		
	33	21	A1	0	Frequency jump 2A	✓	✓	✓	✓	—	✓	✓		
	34	22	A2	0	Frequency jump 2B	✓	✓	✓	✓	—	✓	✓		
	35	23	A3	0	Frequency jump 3A	✓	✓	✓	✓	—	✓	✓		
	36	24	A4	0	Frequency jump 3B	✓	✓	✓	✓	—	✓	✓		
—	37	25	A5	0	Speed display	✓	✓	✓	✓	✓	✓	✓	6-318	

Tab. A-5: Parameter list with instruction codes (2)

Function	Parameter	Instruction Code			Name	Control Mode-based Correspondence Table							Refer to Page	Customer Setting
		Read	Write	Extended		V/f Control	Advanced magnetic flux vector control	Vector control			Real sensorless vector control			
								Speed	Torque	Position	Speed	Torque		
Frequency detection	41	29	A9	0	Up-to-frequency sensitivity	✓	✓	✓	—	—	✓	—	6-309	
	42	2A	AA	0	Output frequency detection	✓	✓	✓	✓	✓	✓	✓		
	43	2B	AB	0	Output frequency detection for reverse rotation	✓	✓	✓	✓	✓	✓	✓		
Second functions	44	2C	AC	0	Second acceleration/deceleration time	✓	✓	✓	✓	△	✓	✓	6-195	
	45	2D	AD	0	Second deceleration time	✓	✓	✓	✓	△	✓	✓		
	46	2E	AE	0	Second torque boost	✓	—	—	—	—	—	—	6-147	
	47	2F	AF	0	Second V/F (base frequency)	✓	—	—	—	—	—	—	6-172	
	48	30	B0	0	Second stall prevention operation current	✓	✓	—	—	—	—	—	6-155	
	49	31	B1	0	Second stall prevention operation frequency	✓	✓	—	—	—	—	—	6-155	
	50	32	B2	0	Second output frequency detection	✓	✓	✓	✓	✓	✓	✓	6-309	
Monitor functions	51	33	B3	0	Second electronic thermal O/L relay	✓	✓	✓	✓	✓	✓	✓	6-212	
	52	34	B4	0	DU/PU main display data selection	✓	✓	✓	✓	✓	✓	✓	6-321	
	54	36	B6	0	CA terminal function selection	✓	✓	✓	✓	✓	✓	✓	6-330	
	55	37	B7	0	Frequency monitoring reference	✓	✓	✓	✓	✓	✓	✓	6-330	
Automatic restart functions	56	38	B8	0	Current monitoring reference	✓	✓	✓	✓	✓	✓	✓	6-330	
	57	39	B9	0	Restart coasting time	✓	✓	✓	✓	—	✓	✓	6-337	
	58	3A	BA	0	Restart cushion time	✓	✓	—	—	—	—	—	6-337	
—	59	3B	BB	0	Remote function selection	✓	✓	✓	✓	—	✓	✓	6-191	
—	60	3C	BC	0	Energy saving control selection	✓	✓	—	—	—	—	—	6-359	
Automatic acceleration/deceleration	61	3D	BD	0	Reference current	✓	✓	✓	—	—	✓	—	6-178, 6-208	
	62	3E	BE	0	Reference value at acceleration	✓	✓	✓	—	—	✓	—	6-208	
	63	3F	BF	0	Reference value at deceleration	✓	✓	✓	—	—	✓	—	6-208	
	64	40	C0	0	Starting frequency for elevator mode	✓	—	—	—	—	—	—	6-178	
Retry function	65	41	C1	0	Retry selection	✓	✓	✓	✓	—	✓	✓	6-351	
—	66	42	C2	0	Stall prevention operation reduction starting frequency	✓	✓	—	—	—	—	—	6-155	

Tab. A-5: Parameter list with instruction codes (3)

Function	Parameter	Instruction Code			Name	Control Mode-based Correspondence Table							Refer to Page	Customer Setting
		Read	Write	Extended		V/f Control	Advanced magnetic flux vector control	Vector control			Realsensorless vector control			
								Speed	Torque	Position	Speed	Torque		
Retry function	67	43	C3	0	Number of retries at alarm occurrence	✓	✓	✓	✓	—	✓	✓	6-351	
	68	44	C4	0	Retry waiting time	✓	✓	✓	✓	—	✓	✓		
	69	45	C5	0	Retry count display erase	✓	✓	✓	✓	—	✓	✓		
—	70	46	C6	0	Special regenerative brake duty	✓	✓	✓	✓	✓	✓	✓	6-247	
—	71	47	C7	0	Applied motor	✓	✓	✓	✓	✓	✓	✓	6-218	
—	72	48	C8	0	PWM frequency selection	✓	✓	✓	✓	✓	✓	✓	6-367	
—	73	49	C9	0	Analog input selection	✓	✓	✓	✓	—	✓	✓	6-371	
—	74	4A	CA	0	Input filter time constant	✓	✓	✓	✓	—	✓	✓	6-380	
—	75	4B	CB	0	Reset selection/disconnected PU detection / PU stop selection	✓	✓	✓	✓	✓	✓	✓	6-403	
—	76	4C	CC	0	Alarm code output selection	✓	✓	✓	✓	✓	✓	✓	6-355	
—	77	4D	CD ①	0	Parameter write selection	✓	✓	✓	✓	✓	✓	✓	6-408	
—	78	4E	CE	0	Reverse rotation prevention selection	✓	✓	✓	✓	✓	✓	✓	6-411	
—	Ⓢ 79	4F	CF ①	0	Operation mode selection	✓	✓	✓	✓	✓	✓	✓	6-415	
Motor constants	80	50	D0	0	Motor capacity	—	✓	✓	✓	✓	✓	✓	6-150, 6-222	
	81	51	D1	0	Number of motor poles	—	✓	✓	✓	✓	✓	✓	6-150, 6-222	
	82	52	D2	0	Motor excitation current	—	✓	✓	✓	✓	✓	✓	6-222	
	83	53	D3	0	Motor rated voltage	—	✓	✓	✓	✓	✓	✓	6-222	
	84	54	D4	0	Rated motor frequency	—	✓	✓	✓	✓	✓	✓	6-222	
	89	59	D9	0	Speed control gain (magnetic flux vector)	—	✓	—	—	—	—	—	6-150	
	90	5A	DA	0	Motor constant (R1)	—	✓	✓	✓	✓	✓	✓	6-222	
	91	5B	DB	0	Motor constant (R2)	—	✓	✓	✓	✓	✓	✓	6-222	
	92	5C	DC	0	Motor constant (L1)	—	✓	✓	✓	✓	✓	✓	6-222	
	93	5D	DD	0	Motor constant (L2)	—	✓	✓	✓	✓	✓	✓	6-222	
	94	5E	DE	0	Motor constant (X)	—	✓	✓	✓	✓	✓	✓	6-222	
	95	5F	DF	0	Online auto tuning selection	—	✓	✓	✓	✓	✓	✓	6-236	
96	60	E0	0	Auto tuning setting/status	—	✓	✓	✓	✓	✓	✓	6-222		

Tab. A-5: Parameter list with instruction codes (4)

① Can be written by only communication from the PU connector.

Function	Parameter	Instruction Code			Name	Control Mode-based Correspondence Table							Refer to Page	Customer Setting
		Read	Write	Extended		V/f Control	Advanced magnetic flux vector control	Vector control			Realsensorless vector control			
								Speed	Torque	Position	Speed	Torque		
Adjustable 5 points V/f	100	00	80	1	V/f1 (first frequency)	✓	—	—	—	—	—	6-181		
	101	01	81	1	V/f1 (first frequency voltage)	✓	—	—	—	—	—			
	102	02	82	1	V/f2 (second frequency)	✓	—	—	—	—	—			
	103	03	83	1	V/f2 (second frequency voltage)	✓	—	—	—	—	—			
	104	04	84	1	V/f3 (third frequency)	✓	—	—	—	—	—			
	105	05	85	1	V/f3 (third frequency voltage)	✓	—	—	—	—	—			
	106	06	86	1	V/f4 (fourth frequency)	✓	—	—	—	—	—			
	107	07	87	1	V/f4 (fourth frequency voltage)	✓	—	—	—	—	—			
	108	08	88	1	V/f5 (fifth frequency)	✓	—	—	—	—	—			
	109	09	89	1	V/f5 (fifth frequency voltage)	✓	—	—	—	—	—			
Third functions	110	0A	8A	1	Third acceleration/deceleration time	✓	✓	✓	✓	Δ	✓	✓	6-195	
	111	0B	8B	1	Third deceleration time	✓	✓	✓	✓	Δ	✓	✓	6-195	
	112	0C	8C	1	Third torque boost	✓	—	—	—	—	—	—	6-147	
	113	0D	8D	1	Third V/f (base frequency)	✓	—	—	—	—	—	—	6-172	
	114	0E	8E	1	Third stall prevention operation current	✓	✓	—	—	—	—	—	6-155	
	115	0F	8F	1	Third stall prevention operation frequency	✓	✓	—	—	—	—	—	6-155	
	116	10	90	1	Third output frequency detection	✓	✓	✓	✓	✓	✓	✓	6-309	
PU connector communication	117	11	91	1	PU communication station number	✓	✓	✓	✓	✓	✓	6-445		
	118	12	92	1	PU communication speed	✓	✓	✓	✓	✓	✓			
	119	13	93	1	PU communication stop bit length	✓	✓	✓	✓	✓	✓			
	120	14	94	1	PU communication parity check	✓	✓	✓	✓	✓	✓			
	121	15	95	1	Number of PU communication retries	✓	✓	✓	✓	✓	✓			
	122	16	96	1	PU communication check time interval	✓	✓	✓	✓	✓	✓			
	123	17	97	1	PU communication waiting time setting	✓	✓	✓	✓	✓	✓			
	124	18	98	1	PU communication CR/LF presence/absence selection	✓	✓	✓	✓	✓	✓			
—	Ⓢ125	19	99	1	Terminal 2 frequency setting gain frequency	✓	✓	✓	✓	—	✓	✓	6-382	
—	Ⓢ126	1A	9A	1	Terminal 4 frequency setting gain frequency	✓	✓	✓	✓	—	✓	✓		

Tab. A-5: Parameter list with instruction codes (5)



Function	Parameter	Instruction Code			Name	Control Mode-based Correspondence Table						Refer to Page	Customer Setting	
		Read	Write	Extended		V/f Control	Advanced magnetic flux vector control	Vector control			Realsensorless vector control			
								Speed	Torque	Position	Speed			Torque
PID operation	127	1B	9B	1	PID control automatic switch over frequency	✓	✓	✓	—	—	✓	—	6-488	
	128	1C	9C	1	PID action selection	✓	✓	✓	—	—	✓	—		
	129	1D	9D	1	PID proportional band	✓	✓	✓	—	—	✓	—		
	130	1E	9E	1	PID integral time	✓	✓	✓	—	—	✓	—		
	131	1F	9F	1	PID upper limit	✓	✓	✓	—	—	✓	—		
	132	20	A0	1	PID lower limit	✓	✓	✓	—	—	✓	—		
	133	21	A1	1	PID action set point	✓	✓	✓	—	—	✓	—		
	134	22	A2	1	PID differential time	✓	✓	✓	—	—	✓	—		
Electronic bypass	135	23	A3	1	Electronic bypass sequence selection	✓	✓	✓	—	—	✓	—	6-502	
	136	24	A4	1	MC switch over interlock time	✓	✓	✓	—	—	✓	—		
	137	25	A5	1	Start waiting time	✓	✓	✓	—	—	✓	—		
	138	26	A6	1	Bypass selection at an alarm	✓	✓	✓	—	—	✓	—		
	139	27	A7	1	Automatic switchover frequency from inverter to bypass operation	✓	✓	✓	—	—	✓	—		
Backlash measures	140	28	A8	1	Backlash acceleration stopping frequency	✓	✓	✓	✓	—	✓	✓	6-201	
	141	29	A9	1	Backlash acceleration stopping time	✓	✓	✓	✓	—	✓	✓		
	142	2A	AA	1	Backlash deceleration stopping frequency	✓	✓	✓	✓	—	✓	✓		
	143	2B	AB	1	Backlash deceleration stopping time	✓	✓	✓	✓	—	✓	✓		
—	144	2C	AC	1	Speed setting switchover	✓	✓	✓	✓	✓	✓	✓	6-318	
PU	145	2D	AD	1	PU display language selection	✓	✓	✓	✓	✓	✓	✓	6-537	
Current detection	148	30	B0	1	Stall prevention level at 0 V input	✓	✓	—	—	—	—	—	6-155	
	149	31	B1	1	Stall prevention level at 10 V input	✓	✓	—	—	—	—	—		
	150	32	B2	1	Output current detection level	✓	✓	✓	✓	✓	✓	✓	6-312	
	151	33	B3	1	Output current detection signal delay time	✓	✓	✓	✓	✓	✓	✓		
	152	34	B4	1	Zero current detection level	✓	✓	✓	✓	✓	✓	✓		
	153	35	B5	1	Zero current detection time	✓	✓	✓	✓	✓	✓	✓		

Tab. A-5: Parameter list with instruction codes (6)

Function	Parameter	Instruction Code			Name	Control Mode-based Correspondence Table							Refer to Page	Customer Setting
		Read	Write	Extended		V/f Control	Advanced magnetic flux vector control	Vector control			Realsensorless vector control			
								Speed	Torque	Position	Speed	Torque		
—	154	36	B6	1	Voltage reduction selection during stall prevention operation	✓	✓	—	—	—	—	—	6-155	
—	155	37	B7	1	RT signal function validity condition selection	✓	✓	✓	—	—	✓	—	6-292	
—	156	38	B8	1	Stall prevention operation selection	✓	✓	—	—	—	—	—	6-155	
—	157	39	B9	1	OL signal output timer	✓	✓	✓	✓	✓	✓	✓	6-155	
—	158	3A	BA	1	AM terminal function selection	✓	✓	✓	✓	✓	✓	✓	6-330	
—	159	3B	BB	1	Automatic switchover frequency range from bypass to inverter operation	✓	✓	✓	—	—	✓	—	6-502	
—	① 160	00	80	2	User group read selection	✓	✓	✓	✓	✓	✓	✓	6-412	
—	161	01	81	2	Frequency setting/key lock operation selection	✓	✓	✓	✓	✓	✓	✓	6-538	
Automatic restart functions	162	02	82	2	Automatic restart after instantaneous power failure selection	✓	✓	✓	✓	—	✓	✓	6-337	
	163	03	83	2	First cushion time for restart	✓	✓	—	—	—	—	—		
	164	04	84	2	First cushion voltage for restart	✓	✓	—	—	—	—	—		
	165	05	85	2	Stall prevention operation level for restart	✓	✓	—	—	—	—	—		
Current detection	166	06	86	2	Output current detection signal retention time	✓	✓	✓	✓	✓	✓	✓	6-312	
	167	07	87	2	Output current detection operation selection	✓	✓	✓	✓	✓	✓	✓		
—	168	Parameter for manufacturer setting. Do not make setting.												
—	169													
Cumulative monitor clear	170	0A	8A	2	Watt-hour meter clear	✓	✓	✓	✓	✓	✓	✓	6-321	
	171	0B	8B	2	Operation hour meter clear	✓	✓	✓	✓	✓	✓	✓		
User group	172	0C	8C	2	User group registered display/batch clear	✓	✓	✓	✓	✓	✓	✓	6-412	
	173	0D	8D	2	User group registration	✓	✓	✓	✓	✓	✓	✓		
	174	0E	8E	2	User group clear	✓	✓	✓	✓	✓	✓	✓		

Tab. A-5: Parameter list with instruction codes (7)

Function	Parameter	Instruction Code			Name	Control Mode-based Correspondence Table							Refer to Page	Customer Setting
		Read	Write	Extended		V/f Control	Advanced magnetic flux vector control	Vector control			Realsensorless vector control			
								Speed	Torque	Position	Speed	Torque		
Input terminal function assignment	178	12	92	2	STF terminal function selection	✓	✓	✓	✓	✓	✓	✓	6-286	
	179	13	93	2	STR terminal function selection	✓	✓	✓	✓	✓	✓	✓	6-286	
	180	14	94	2	RL terminal function selection	✓	✓	✓	✓	✓	✓	✓	6-286	
	181	15	95	2	RM terminal function selection	✓	✓	✓	✓	✓	✓	✓	6-286	
	182	16	96	2	RH terminal function selection	✓	✓	✓	✓	✓	✓	✓	6-286	
	183	17	97	2	RT terminal function selection	✓	✓	✓	✓	✓	✓	✓	6-286	
	184	18	98	2	AU terminal function selection	✓	✓	✓	✓	✓	✓	✓	6-286	
	185	19	99	2	JOG terminal function selection	✓	✓	✓	✓	✓	✓	✓	6-286	
	186	1A	9A	2	CS terminal function selection	✓	✓	✓	✓	✓	✓	✓	6-286	
	187	1B	9B	2	MRS terminal function selection	✓	✓	✓	✓	✓	✓	✓	6-286	
	188	1C	9C	2	STOP terminal function selection	✓	✓	✓	✓	✓	✓	✓	6-286	
	189	1D	9D	2	RES terminal function selection	✓	✓	✓	✓	✓	✓	✓	6-286	
Output terminal function assignment	190	1E	9E	2	RUN terminal function selection	✓	✓	✓	✓	✓	✓	✓	6-298	
	191	1F	9F	2	SU terminal function selection	✓	✓	✓	✓	✓	✓	✓	6-298	
	192	20	A0	2	IPF terminal function selection	✓	✓	✓	✓	✓	✓	✓	6-298	
	193	21	A1	2	OL terminal function selection	✓	✓	✓	✓	✓	✓	✓	6-298	
	194	22	A2	2	FU terminal function selection	✓	✓	✓	✓	✓	✓	✓	6-298	
	195	23	A3	2	ABC1 terminal function selection	✓	✓	✓	✓	✓	✓	✓	6-298	
	196	24	A4	2	ABC2 terminal function selection	✓	✓	✓	✓	✓	✓	✓	6-298	
Multi-speed setting	232 – 239	28 – 2F	A8 – AF	2	Multi-speed setting (speeds 8 to 15)	✓	✓	✓	✓	□	✓	✓	6-183	
—	240	30	B0	2	Soft-PWM operation selection	✓	✓	✓	✓	✓	✓	✓	6-367	
—	241	31	B1	2	Analog input display unit switch over	✓	✓	✓	✓	✓	✓	✓	6-382	
—	242	32	B2	2	Terminal 1 added compensation amount (terminal 2)	✓	✓	✓	✓	—	✓	✓	6-371	
—	243	33	B3	2	Terminal 1 added compensation amount (terminal 4)	✓	✓	✓	✓	—	✓	✓	6-371	
—	244	34	B4	2	Cooling fan operation selection	✓	✓	✓	✓	✓	✓	✓	6-526	

Tab. A-5: Parameter list with instruction codes (8)

Function	Parameter	Instruction Code			Name	Control Mode-based Correspondence Table							Refer to Page	Customer Setting
		Read	Write	Extended		V/f Control	Advanced magnetic flux vector control	Vector control			Realsensorless vector control			
								Speed	Torque	Position	Speed	Torque		
Slip compensation	245	35	B5	2	Rated slip	✓	—	—	—	—	—	—	6-154	
	246	36	B6	2	Slip compensation time constant	✓	—	—	—	—	—	—	6-154	
	247	37	B7	2	Constant-output region slip compensation selection	✓	—	—	—	—	—	—	6-154	
—	250	3A	BA	2	Stop selection	✓	✓	✓	✓	—	✓	✓	6-255	
—	251	3B	BB	2	Output phase failure protection selection	✓	✓	✓	✓	✓	✓	✓	6-356	
Frequency compensation function	252	3C	BC	2	Override bias	✓	✓	✓	✓	—	✓	✓	6-371	
	253	3D	BD	2	Override gain	✓	✓	✓	✓	—	✓	✓	6-371	
Life check	255	3F	BF	2	Life alarm status display	✓	✓	✓	✓	✓	✓	✓	6-527	
	256	40	C0	2	Inrush current limit circuit life display	✓	✓	✓	✓	✓	✓	✓	6-527	
	257	41	C1	2	Control circuit capacitor life display	✓	✓	✓	✓	✓	✓	✓	6-527	
	258	42	C2	2	Main circuit capacitor life display	✓	✓	✓	✓	✓	✓	✓	6-527	
	259	43	C3	2	Main circuit capacitor life measuring	✓	✓	✓	✓	✓	✓	✓	6-527	
—	260	44	C4	2	PWM frequency automatic switchover	✓	✓	✓	✓	✓	✓	✓	6-367	
Power failure stop	261	45	C5	2	Power failure stop selection	✓	✓	✓	✓	—	✓	✓	6-346	
	262	46	C6	2	Subtracted frequency at deceleration start	✓	✓	✓	✓	—	✓	✓	6-346	
	263	47	C7	2	Subtraction starting frequency	✓	✓	✓	✓	—	✓	✓	6-346	
	264	48	C8	2	Power-failure deceleration time 1	✓	✓	✓	✓	—	✓	✓	6-346	
	265	49	C9	2	Power-failure deceleration time 2	✓	✓	✓	✓	—	✓	✓	6-346	
	266	4A	CA	2	Power failure deceleration time switch over frequency	✓	✓	✓	✓	—	✓	✓	6-346	
—	267	4B	CB	2	Terminal 4 input selection	✓	✓	✓	✓	✓	✓	✓	6-371	
—	268	4C	CC	2	Monitor decimal digits selection	✓	✓	✓	✓	✓	✓	✓	6-321	
—	269	Parameter for manufacturer setting. Do not make setting.												

Tab. A-5: Parameter list with instruction codes (9)

Function	Parameter	Instruction Code			Name	Control Mode-based Correspondence Table						Refer to Page	Customer Setting	
		Read	Write	Extended		V/f Control	Advanced magnetic flux vector control	Vector control			Realsensorless vector control			
								Speed	Torque	Position	Speed			Torque
—	270	4E	CE	2	Stop-on contact/load torque highspeed frequency control selection	✓	✓	✓	—	—	✓	—	6-257, 6-509	
Load torque high speed frequency control	271	4F	CF	2	High-speed setting maximum current	✓	✓	✓	—	—	✓	—	6-509	
	272	50	D0	2	Middle-speed setting minimum current	✓	✓	✓	—	—	✓	—	6-509	
	273	51	D1	2	Current averaging range	✓	✓	✓	—	—	✓	—	6-509	
	274	52	D2	2	Current averaging filter time constant	✓	✓	✓	—	—	✓	—	6-509	
Stop-on contact control	275	53	D3	2	Stop-on contact excitation current lowspeed multiplying factor	—	✓	—	—	—	—	—	6-257	
	276	54	D4	2	PWM carrier frequency at stop-on contact	—	✓	—	—	—	—	—	6-257	
Brake sequence function	278	56	D6	2	Brake opening frequency	—	✓	✓	—	—	✓	—	6-261	
	279	57	D7	2	Brake opening current	—	✓	✓	—	—	✓	—	6-261	
	280	58	D8	2	Brake opening current detection time	—	✓	✓	—	—	✓	—	6-261	
	281	59	D9	2	Brake operation time at start	—	✓	✓	—	—	✓	—	6-261	
	282	5A	DA	2	Brake operation frequency	—	✓	✓	—	—	✓	—	6-261	
	283	5B	DB	2	Brake operation time at stop	—	✓	✓	—	—	✓	—	6-261	
	284	5C	DC	2	Deceleration detection function selection	✓	✓	✓	—	—	—	—	6-261	
Droop control	286	5E	DE	2	Droop gain	—	✓	✓	—	—	✓	—	6-512	
	287	5F	DF	2	Droop filter time constant	—	✓	✓	—	—	✓	—	6-512	
	288	60	E0	2	Droop function activation selection	—	—	✓	—	—	✓	—	6-512	
—	291	63	E3	2	Pulse train input selection	✓	✓	✓	✓	—	✓	✓	6-514	
—	292	64	E4	2	Automatic acceleration/deceleration	✓	✓	✓	—	—	✓	—	6-178, 6-208, 6-261	
—	293	65	E5	2	Acceleration/deceleration separate selection	✓	✓	✓	—	—	✓	—	6-208	
—	294	66	E6	2	UV avoidance voltage gain	✓	✓	✓	✓	—	✓	✓	6-346	
—	299	6B	EB	2	Rotation direction detection selection at restarting	✓	✓	—	—	—	✓	—	6-337	

Tab. A-5: Parameter list with instruction codes (10)

Function	Parameter	Instruction Code			Name	Control Mode-based Correspondence Table							Refer to Page	Customer Setting
		Read	Write	Extended		V/f Control	Advanced magnetic flux vector control	Vector control			Realsensorless vector control			
								Speed	Torque	Position	Speed	Torque		
Parameter for option FR-A7AX (Digital inputs)	300	00	80	3	BCD input bias	✓	✓	✓	✓	—	✓	✓	—	
	301	01	81	3	BCD input gain	✓	✓	✓	✓	—	✓	✓		
	302	02	82	3	BIN input bias	✓	✓	✓	✓	—	✓	✓		
	303	03	83	3	BIN input gain	✓	✓	✓	✓	—	✓	✓		
	304	04	84	3	Digital input and analog input compensation enable/disable selection	✓	✓	✓	✓	—	✓	✓		
	305	05	85	3	Read timing operation selection	✓	✓	✓	✓	—	✓	✓		
Parameter for option FR-A7AY (Analog output)	306	06	86	3	Analog output signal selection	✓	✓	✓	✓	✓	✓	✓	—	
	307	07	87	3	Setting for zero analog output	✓	✓	✓	✓	✓	✓	✓		
	308	08	88	3	Setting for maximum analog output	✓	✓	✓	✓	✓	✓	✓		
	309	09	89	3	Analog output signal voltage/current switchover	✓	✓	✓	✓	✓	✓	✓		
	310	0A	8A	3	Analog meter voltage output selection	✓	✓	✓	✓	✓	✓	✓		
	311	0B	8B	3	Setting for zero analog meter voltage output	✓	✓	✓	✓	✓	✓	✓		
	312	0C	8C	3	Setting for maximum analog meter voltage output	✓	✓	✓	✓	✓	✓	✓		
Parameter for option FR-A7AY (Digital output)	313	0D	8D	3	Y0 terminal function selection	✓	✓	✓	✓	✓	✓	✓	—	
	314	0E	8E	3	Y1 terminal function selection	✓	✓	✓	✓	✓	✓	✓		
	315	0F	8F	3	Y2 terminal function selection	✓	✓	✓	✓	✓	✓	✓		
	316	10	90	3	Y3 terminal function selection	✓	✓	✓	✓	✓	✓	✓		
	317	11	91	3	Y4 terminal function selection	✓	✓	✓	✓	✓	✓	✓		
	318	12	92	3	Y5 terminal function selection	✓	✓	✓	✓	✓	✓	✓		
	319	13	93	3	Y6 terminal function selection	✓	✓	✓	✓	✓	✓	✓		
Parameter for option FR-A7AR (Relay output)	320	14	94	3	RA1 terminal function selection	✓	✓	✓	✓	✓	✓	✓	—	
	321	15	95	3	RA2 terminal function selection	✓	✓	✓	✓	✓	✓	✓		
	322	16	96	3	RA3 terminal function selection	✓	✓	✓	✓	✓	✓	✓		

Tab. A-5: Parameter list with instruction codes (11)

Function	Parameter	Instruction Code			Name	Control Mode-based Correspondence Table							Refer to Page	Customer Setting
		Read	Write	Extended		V/f Control	Advanced magnetic flux vector control	Vector control			Realsensorless vector control			
								Speed	Torque	Position	Speed	Torque		
Parameter for option FR-A7AY (Analog/digital output)	323	17	97	3	AM0 0V adjustment	✓	✓	✓	✓	✓	✓	✓	—	
	324	18	98	3	AM1 0mA adjustment	✓	✓	✓	✓	✓	✓	✓		
Parameter for option FR-A7AX (Digital inputs)	329	1D	9D	3	Digital input unit selection	✓	✓	✓	✓	—	✓	✓		
RS-485 communication	331	1F	9F	3	RS-485 communication station number	✓	✓	✓	✓	✓	✓	✓	6-445	
	332	20	A0	3	RS-485 communication speed	✓	✓	✓	✓	✓	✓	✓		
	333	21	A1	3	RS-485 communication stop bit length	✓	✓	✓	✓	✓	✓	✓		
	334	22	A2	3	RS-485 communication parity check selection	✓	✓	✓	✓	✓	✓	✓		
	335	23	A3	3	RS-485 communication number of retries	✓	✓	✓	✓	✓	✓	✓		
	336	24	A4	3	RS-485 communication check time interval	✓	✓	✓	✓	✓	✓	✓		
	337	25	A5	3	RS-485 communication waiting time setting	✓	✓	✓	✓	✓	✓	✓		
	338	26	A6	3	Communication operation command source	✓	✓	✓	✓	✓	✓	✓	6-429	
	339	27	A7	3	Communication speed command source	✓	✓	✓	✓	✓	✓	✓		
	340	28	A8	3	Communication startup mode selection	✓	✓	✓	✓	✓	✓	✓	6-415	
	341	29	A9	3	RS-485 communication CR/LF selection	✓	✓	✓	✓	✓	✓	✓	6-445	
	342	2A	AA	3	Communication E <sup>2</sup> PROM write selection	✓	✓	✓	✓	✓	✓	✓		
343	2B	AB	3	Communication error count	✓	✓	✓	✓	✓	✓	✓			
Parameter for option FR-A7ND (DeviceNet)	345	2D	AD	3	DeviceNet address	✓	✓	✓	✓	✓	✓	✓	—	
	346	2E	AE	3	DeviceNet baud rate	✓	✓	✓	✓	✓	✓	✓		
Parameter for option FR-A7NCA (CANopen)	347	2F	AF	3	CANopen address	✓	✓	✓	✓	✓	✓	✓	—	
	348	30	B0	3	CANopen baud rate	✓	✓	✓	✓	✓	✓	✓		

Tab. A-5: Parameter list with instruction codes (12)

Function	Parameter	Instruction Code			Name	Control Mode-based Correspondence Table						Refer to Page	Customer Setting	
		Read	Write	Extended		V/f Control	Advanced magnetic flux vector control	Vector control			Real sensorless vector control			
								Speed	Torque	Position	Speed			Torque
Parameter for communication options FR-A7NC, -A7NCA, -A7ND, -A7NL, -A7NP	349	31	B1	3	Communication reset selection	✓	✓	✓	✓	✓	✓	✓	—	
Orientation control	350 <sup>①</sup>	32	B2	3	Stop position command selection	✓	✓	✓	—	—	—	—	6-266	
	351 <sup>①</sup>	33	B3	3	Orientation speed	✓	✓	✓	—	—	—	—	6-266	
	352 <sup>①</sup>	34	B4	3	Creep speed	✓	✓	✓	—	—	—	—	6-266	
	353 <sup>①</sup>	35	B5	3	Creep switchover position	✓	✓	✓	—	—	—	—	6-266	
	354 <sup>①</sup>	36	B6	3	Position loop switchover position	✓	✓	✓	—	—	—	—	6-266	
	355 <sup>①</sup>	37	B7	3	DC injection brake start position	✓	✓	✓	—	—	—	—	6-266	
	356 <sup>①</sup>	38	B8	3	Internal stop position command	✓	✓	✓	—	—	—	—	6-266	
	357 <sup>①</sup>	39	B9	3	Orientation in-position zone	✓	✓	✓	—	—	—	—	6-266	
	358 <sup>①</sup>	3A	BA	3	Servo torque selection	✓	✓	✓	—	—	—	—	6-266	
	359 <sup>①</sup>	3B	BB	3	Encoder rotation direction	✓	✓	✓	✓	✓	✓	✓	6-266	
	360 <sup>①</sup>	3C	BC	3	16 bit data selection	✓	✓	✓	—	—	—	—	6-266	
	361 <sup>①</sup>	3D	BD	3	Position shift	✓	✓	✓	—	—	—	—	6-266	
	362 <sup>①</sup>	3E	BE	3	Orientation position loop gain	✓	✓	✓	—	—	—	—	6-266	
	363 <sup>①</sup>	3F	BF	3	Completion signal output delay time	✓	✓	✓	—	—	—	—	6-266	
	364 <sup>①</sup>	40	C0	3	Encoder stop check time	✓	✓	✓	—	—	—	—	6-266	
	365 <sup>①</sup>	41	C1	3	Orientation limit	✓	✓	✓	—	—	—	—	6-266	
366 <sup>①</sup>	42	C2	3	Recheck time	✓	✓	✓	—	—	—	—	6-266		
Encoder feedback	367 <sup>①</sup>	43	C3	3	Speed feedback range	✓	✓	✓	—	—	—	—	6-517	
	368 <sup>①</sup>	44	C4	3	Feedback gain	✓	✓	—	—	—	—	—	6-517	
	369 <sup>①</sup>	45	C5	3	Number of encoder pulses	✓	✓	✓	✓	✓	✓	✓	6-266, 6-517	
	374	4A	CA	3	Overspeed detection level	—	—	✓	✓	✓	—	—	6-357	
	376 <sup>①</sup>	4C	CC	3	Encoder signal loss detection enable/disable selection	✓	✓	✓	✓	✓	—	—	6-357	

Tab. A-5: Parameter list with instruction codes (13)

① Setting can be made only when the FR-A7AP is mounted.



Function	Parameter	Instruction Code			Name	Control Mode-based Correspondence Table							Refer to Page	Customer Setting
		Read	Write	Extended		V/f Control	Advanced magnetic flux vector control	Vector control			Real sensorless vector control			
								Speed	Torque	Position	Speed	Torque		
S-pattern acceleration/deceleration C	380	50	D0	3	Acceleration S-pattern 1	✓	✓	✓	✓	—	✓	✓	6-201	
	381	51	D1	3	Deceleration S-pattern 1	✓	✓	✓	✓	—	✓	✓	6-201	
	382	52	D2	3	Acceleration S-pattern 2	✓	✓	✓	✓	—	✓	✓	6-201	
	383	53	D3	3	Deceleration S-pattern 2	✓	✓	✓	✓	—	✓	✓	6-201	
Pulse train input	384	54	D4	3	Input pulse division scaling factor	✓	✓	✓	✓	—	✓	✓	6-514	
	385	55	D5	3	Frequency for 0 input pulse	✓	✓	✓	✓	—	✓	✓	6-514	
	386	56	D6	3	Frequency for maximum input pulse	✓	✓	✓	✓	—	✓	✓	6-514	
Parameter for option FR-A7NL (LONWORKS communication)	387	57	D7	3	Initial communication delay time	✓	✓	✓	✓	✓	✓	✓	—	
	388	58	D8	3	Send time interval at heart beat	✓	✓	✓	✓	✓	✓	✓		
	389	59	D9	3	Minimum sending time at heart beat	✓	✓	✓	✓	✓	✓	✓		
	390	5A	DA	3	% setting reference frequency	✓	✓	✓	✓	✓	✓	✓		
	391	5B	DB	3	Receive time interval at heart beat	✓	✓	✓	✓	✓	✓	✓		
	392	5C	DC	3	Event driven detection width	✓	✓	✓	✓	✓	✓	✓		
Orientation control	393 <sup>①</sup>	5D	DD	3	Orientation selection	—	—	✓	—	—	—	—	6-266	
	396 <sup>①</sup>	60	E0	3	Orientation speed gain (P term)	—	—	✓	—	—	—	—	6-266	
	397 <sup>①</sup>	61	E1	3	Orientation speed integral time	—	—	✓	—	—	—	—	6-266	
	398 <sup>①</sup>	62	E2	3	Orientation speed gain (D term)	—	—	✓	—	—	—	—	6-266	
	399 <sup>①</sup>	63	E3	3	Orientation deceleration ratio	—	—	✓	—	—	—	—	6-266	
PLC function	414	0E	8E	4	PLC function operation selection	✓	✓	✓	✓	✓	✓	✓	6-486	
	415	0F	8F	4	Inverter operation lock mode setting	✓	✓	✓	✓	✓	✓	✓	6-486	
	416	10	90	4	Pre-scale function selection	✓	✓	✓	✓	✓	✓	✓	6-486	
	417	11	91	4	Pre-scale setting value	✓	✓	✓	✓	✓	✓	✓	6-486	
Position control	419 <sup>①</sup>	13	93	4	Position command source selection	—	—	—	—	✓	—	—	6-131, 6-134	
	420 <sup>①</sup>	14	94	4	Command pulse scaling factor numerator	—	—	—	—	✓	—	—	6-137	
	421 <sup>①</sup>	15	95	4	Command pulse scaling factor denominator	—	—	—	—	✓	—	—	6-137	
	422 <sup>①</sup>	16	96	4	Position loop gain	—	—	—	—	✓	—	—	6-141	
	423 <sup>①</sup>	17	97	4	Position feed forward gain	—	—	—	—	✓	—	—	6-141	

Tab. A-5: Parameter list with instruction codes (14)

① Setting can be made only when the FR-A7AP is mounted.

Function	Parameter	Instruction Code			Name	Control Mode-based Correspondence Table							Refer to Page	Customer Setting
		Read	Write	Extended		V/f Control	Advanced magnetic flux vector control	Vector control			Realsensorless vector control			
								Speed	Torque	Position	Speed	Torque		
Position control	424 <sup>①</sup>	18	98	4	Position command acceleration/deceleration time constant	—	—	—	—	✓	—	—	6-137	
	425 <sup>①</sup>	19	99	4	Position feed forward command filter	—	—	—	—	✓	—	—	6-141	
	426 <sup>①</sup>	1A	9A	4	In-position width	—	—	—	—	✓	—	—	6-140	
	427 <sup>①</sup>	1B	9B	4	Excessive level error	—	—	—	—	✓	—	—	6-140	
	428 <sup>①</sup>	1C	9C	4	Command pulse selection	—	—	—	—	✓	—	—	6-134	
	429 <sup>①</sup>	1D	9D	4	Clear signal selection	—	—	—	—	✓	—	—	6-134	
	430 <sup>①</sup>	1E	9E	4	Pulse monitor selection	—	—	—	—	✓	—	—	6-134	
Parameter for option FR-A7AX (Digital inputs)	447	2F	AF	4	Digital torque command bias	—	—	—	✓	—	—	✓	—	
	448	30	B0	4	Digital torque command gain	—	—	—	✓	—	—	✓	—	
Second motor constants	450	32	B2	4	Second applied motor	✓	✓	—	—	—	✓	✓	6-218	
	451	33	B3	4	Second motor control method selection	✓	✓	—	—	—	✓	✓	6-150	
	453	35	B5	4	Second motor capacity	—	✓	—	—	—	✓	✓	6-150	
	454	36	B6	4	Number of second motor poles	—	✓	—	—	—	✓	✓	6-150	
	455	37	B7	4	Second motor excitation current	—	✓	—	—	—	✓	✓	6-222	
	456	38	B8	4	Rated second motor voltage	—	✓	—	—	—	✓	✓	6-222	
	457	39	B9	4	Rated second motor frequency	—	✓	—	—	—	✓	✓	6-222	
	458	3A	BA	4	Second motor constant (R1)	—	✓	—	—	—	✓	✓	6-222	
	459	3B	BB	4	Second motor constant (R2)	—	✓	—	—	—	✓	✓	6-222	
	460	3C	BC	4	Second motor constant (L1)	—	✓	—	—	—	✓	✓	6-222	
	461	3D	BD	4	Second motor constant (L2)	—	✓	—	—	—	✓	✓	6-222	
	462	3E	BE	4	Second motor constant (X)	—	✓	—	—	—	✓	✓	6-222	
	463	3F	BF	4	Second motor auto tuning setting/status	—	✓	—	—	—	✓	✓	6-222	

Tab. A-5: Parameter list with instruction codes (15)

① Setting can be made only when the FR-A7AP is mounted.

Function	Parameter	Instruction Code			Name	Control Mode-based Correspondence Table						Refer to Page	Customer Setting	
		Read	Write	Extended		V/f Control	Advanced magnetic flux vector control	Vector control			Realsensorless vector control			
								Speed	Torque	Position	Speed			Torque
Conditional position feed function	464 <sup>①</sup>	40	C0	4	Digital position control sudden stop deceleration time	—	—	—	—	✓	—	—	6-131	
	465 <sup>①</sup>	41	C1	4	First position feed amount	—	—	—	—	✓	—	—	6-131	
	466 <sup>①</sup>	42	C2	4										
	467 <sup>①</sup>	43	C3	4	Second position feed amount	—	—	—	—	✓	—	—	6-131	
	468 <sup>①</sup>	44	C4	4										
	469 <sup>①</sup>	45	C5	4	Third position feed amount	—	—	—	—	✓	—	—	6-131	
	470 <sup>①</sup>	46	C6	4										
	471 <sup>①</sup>	47	C7	4	Fourth position feed amount	—	—	—	—	✓	—	—	6-131	
	472 <sup>①</sup>	48	C8	4										
	473 <sup>①</sup>	49	C9	4	Fifth position feed amount	—	—	—	—	✓	—	—	6-131	
	474 <sup>①</sup>	4A	CA	4										
	475 <sup>①</sup>	4B	CB	4	Sixth position feed amount	—	—	—	—	✓	—	—	6-131	
	476 <sup>①</sup>	4C	CC	4										
	477 <sup>①</sup>	4D	CD	4	Seventh position feed amount	—	—	—	—	✓	—	—	6-131	
	478 <sup>①</sup>	4E	CE	4										
	479 <sup>①</sup>	4F	CF	4	Eighth position feed amount	—	—	—	—	✓	—	—	6-131	
	480 <sup>①</sup>	50	D0	4										
	481 <sup>①</sup>	51	D1	4	Ninth position feed amount	—	—	—	—	✓	—	—	6-131	
482 <sup>①</sup>	52	D2	4	lower 4 digits										
	483 <sup>①</sup>	53	D3	4	Tenth position feed amount	—	—	—	—	✓	—	—	6-131	
	484 <sup>①</sup>	54	D4	4										
	485 <sup>①</sup>	55	D5	4	Eleventh position feed amount	—	—	—	—	✓	—	—	6-131	
	486 <sup>①</sup>	56	D6	4										
	487 <sup>①</sup>	57	D7	4	Twelfth position feed amount	—	—	—	—	✓	—	—	6-131	
	488 <sup>①</sup>	58	D8	4										

Tab. A-5: Parameter list with instruction codes (16)

① Setting can be made only when the FR-A7AP is mounted.

Function	Parameter	Instruction Code			Name	Control Mode-based Correspondence Table							Refer to Page	Customer Setting	
		Read	Write	Extended		V/f Control	Advanced magnetic flux vector control	Vector control			Realsensorless vector control				
								Speed	Torque	Position	Speed	Torque			
Conditional position feed function	489 <sup>①</sup>	59	D9	4	Thirteenth position feed amount	lower 4 digits	—	—	—	—	✓	—	—	6-131	
	490 <sup>①</sup>	5A	DA	4	Thirteenth position feed amount	upper 4 digits	—	—	—	—	✓	—	—	6-131	
	491 <sup>①</sup>	5B	DB	4	Fourteenth position feed amount	lower 4 digits	—	—	—	—	✓	—	—	6-131	
	492 <sup>①</sup>	5C	DC	4	Fourteenth position feed amount	upper 4 digits	—	—	—	—	✓	—	—	6-131	
	493 <sup>①</sup>	5D	DD	4	Fifteenth position feed amount	lower 4 digits	—	—	—	—	✓	—	—	6-131	
	494 <sup>①</sup>	5E	DE	4	Fifteenth position feed amount	upper 4 digits	—	—	—	—	✓	—	—	6-131	
Remote output	495	5F	DF	4	Remote output selection		✓	✓	✓	✓	✓	✓	✓	6-315	
	496	60	E0	4	Remote output data 1		✓	✓	✓	✓	✓	✓	✓	6-315	
	497	61	E1	4	Remote output data 2		✓	✓	✓	✓	✓	✓	✓	6-315	
—	498	62	E2	4	PLC function flash memory clear		✓	✓	✓	✓	✓	✓	✓	6-486	
Parameter for communication options FR-A7NC, -A7NCA, -A7ND, -A7NL, -A7NP	500	00	80	5	Communication error execution waiting time		✓	✓	✓	✓	✓	✓	✓	—	
	501	01	81	5	Communication error occurrence count display		✓	✓	✓	✓	✓	✓	✓	—	
	502	02	82	5	Stop mode selection at communication error		✓	✓	✓	✓	✓	✓	✓	—	
Maintenance	503	03	83	5	Maintenance timer		✓	✓	✓	✓	✓	✓	✓	6-531	
	504	04	84	5	Maintenance timer alarm output set time		✓	✓	✓	✓	✓	✓	✓	6-531	
—	505	05	85	5	Speed setting reference		✓	✓	✓	✓	✓	✓	✓	6-318	
PLC function	506	06	86	5	Parameter 1 for user		✓	✓	✓	✓	✓	✓	✓	6-486	
	507	07	87	5	Parameter 2 for user		✓	✓	✓	✓	✓	✓	✓	6-486	
	508	08	88	5	Parameter 3 for user		✓	✓	✓	✓	✓	✓	✓	6-486	
	509	09	89	5	Parameter 4 for user		✓	✓	✓	✓	✓	✓	✓	6-486	
	510	0A	8A	5	Parameter 5 for user		✓	✓	✓	✓	✓	✓	✓	6-486	
	511	0B	8B	5	Parameter 6 for user		✓	✓	✓	✓	✓	✓	✓	6-486	
	512	0C	8C	5	Parameter 7 for user		✓	✓	✓	✓	✓	✓	✓	6-486	
	513	0D	8D	5	Parameter 8 for user		✓	✓	✓	✓	✓	✓	✓	6-486	
	514	0E	8E	5	Parameter 9 for user		✓	✓	✓	✓	✓	✓	✓	6-486	
	515	0F	8F	5	Parameter 10 for user		✓	✓	✓	✓	✓	✓	✓	6-486	

Tab. A-5: Parameter list with instruction codes (17)

① Setting can be made only when the FR-A7AP is mounted.

Function	Parameter	Instruction Code			Name	Control Mode-based Correspondence Table							Refer to Page	Customer Setting
		Read	Write	Extended		V/f Control	Advanced magnetic flux vector control	Vector control			Realsensorless vector control			
								Speed	Torque	Position	Speed	Torque		
S-pattern acceleration/deceleration D	516	10	90	5	S-pattern time at start of acceleration	✓	✓	✓	✓	—	✓	✓	6-201	
	517	11	91	5	S-pattern time at completion of acceleration	✓	✓	✓	✓	—	✓	✓	6-201	
	518	12	92	5	S-pattern time at start of deceleration	✓	✓	✓	✓	—	✓	✓	6-201	
	519	13	93	5	S-pattern time at completion of deceleration	✓	✓	✓	✓	—	✓	✓	6-201	
—	539	27	A7	5	Modbus-RTU communication check time interval	✓	✓	✓	✓	✓	✓	✓	6-201	
Parameter for option FR-A7NC (CC-Link communication)	541	29	A9	5	Frequency command sign selection (CC-Link)	✓	✓	✓	—	—	✓	—	—	
	542	2A	AA	5	Communication station number (CC-Link)	✓	✓	✓	✓	✓	✓	✓		
	543	2B	AB	5	Baud rate (CC-Link)	✓	✓	✓	✓	✓	✓	✓		
	544	2C	AC	5	CC-Link extended setting	✓	✓	✓	✓	✓	✓	✓		
USB	547	2F	AF	5	USB communication station number	✓	✓	✓	✓	✓	✓	✓	6-487	
	548	30	B0	5	USB communication check time interval	✓	✓	✓	✓	✓	✓	✓	6-487	
Communication	549	31	B1	5	Protocol selection	✓	✓	✓	✓	✓	✓	✓	6-445	
	550	32	B2	5	NET mode operation command source selection	✓	✓	✓	✓	✓	✓	✓	6-429	
	551	33	B3	5	PU mode operation command source selection	✓	✓	✓	✓	✓	✓	✓	6-429	
Current average value monitor	555	37	B7	5	Current average time	✓	✓	✓	✓	✓	✓	✓	6-532	
	556	38	B8	5	Data output mask time	✓	✓	✓	✓	✓	✓	✓		
	557	39	B9	5	Current average value monitor signal output reference current	✓	✓	✓	✓	✓	✓	✓		
—	563	3F	BF	5	Energization time carrying-over times	✓	✓	✓	✓	✓	✓	✓	6-321	
—	564	40	C0	5	Operating time carrying-over times	✓	✓	✓	✓	✓	✓	✓		
Second motor constants	569	45	C5	5	Second motor speed control gain	—	✓	—	—	—	—	—	6-150	
Multiple rating	570	46	C6	5	Multiple rating setting	✓	✓	✓	✓	✓	✓	✓	6-166	
—	571	47	C7	5	Holding time at a start	✓	✓	✓	✓	—	✓	✓	6-199	
—	573	49	C9	5	4mA input check selection	✓	✓	✓	✓	—	✓	✓	6-371	
—	574	4A	CA	5	Second motor online auto tuning	—	✓	—	—	—	✓	✓	6-236	

Tab. A-5: Parameter list with instruction codes (18)

Function	Parameter	Instruction Code			Name	Control Mode-based Correspondence Table						Refer to Page	Customer Setting	
		Read	Write	Extended		V/f Control	Advanced magnetic flux vector control	Vector control			Realsensorless vector control			
								Speed	Torque	Position	Speed			Torque
PID control	575	4B	CB	6	Output interruption detection time	✓	✓	✓	—	—	✓	—	6-488	
	576	4C	CC	6	Output interruption detection level	✓	✓	✓	—	—	✓	—		
	577	4D	CD	6	Output interruption cancel level	✓	✓	✓	—	—	✓	—		
Traverse function	592	5C	DC	6	Traverse function selection	✓	✓	✓	—	—	✓	—	6-520	
	593	5D	DD	6	Maximum amplitude amount	✓	✓	✓	—	—	✓	—		
	594	5E	DE	6	Amplitude compensation amount during deceleration	✓	✓	✓	—	—	✓	—		
	595	5F	DF	6	Amplitude compensation amount during acceleration	✓	✓	✓	—	—	✓	—		
	596	60	E0	6	Amplitude acceleration time	✓	✓	✓	—	—	✓	—		
	597	61	E1	6	Amplitude deceleration time	✓	✓	✓	—	—	✓	—		
—	611	0B	8B	6	Acceleration time at a restart	✓	✓	✓	—	—	✓	—	6-337	
—	665	41	C1	6	Regeneration avoidance frequency gain	✓	✓	✓	—	—	✓	—	6-523	
—	684	54	D4	6	Tuning data unit switchover	—	✓	✓	✓	✓	✓	✓	6-222	
Parameter for option FR-A7AZ (Motor thermistor)	750				Motor temperature detection level	✓	✓	✓	✓	✓	✓	✓	—	
	751				Reference motor temperature	✓	✓	✓	✓	✓	✓	✓	—	
—	800	00	80	8	Control method selection	✓	✓	✓	✓	✓	✓	✓	6-70, 6-150	
—	802 <sup>①</sup>	02	82	8	Pre-excitation selection	—	—	✓	—	—	—	—	6-241	
Torque command	803	03	83	8	Constant power range torque characteristic selection	—	—	✓	✓	✓	✓	✓	6-80, 6-113	
	804	04	84	8	Torque command source selection	—	—	—	✓	—	—	✓	6-113	
	805	05	85	8	Torque command value (RAM)	—	—	—	✓	—	—	✓	6-113	
	806	06	86	8	Torque command value (RAM, EEPROM)	—	—	—	✓	—	—	✓	6-113	
Speed limit	807	07	87	8	Speed limit selection	—	—	—	✓	—	—	✓	6-117	
	808	08	88	8	Forward rotation speed limit	—	—	—	✓	—	—	✓	6-117	
	809	09	89	8	Reverse rotation speed limit	—	—	—	✓	—	—	✓	6-117	

Tab. A-5: Parameter list with instruction codes (19)

① Setting can be made only when the FR-A7AP is mounted.

Function	Parameter	Instruction Code			Name	Control Mode-based Correspondence Table							Refer to Page	Customer Setting
		Read	Write	Extended		V/f Control	Advanced magnetic flux vector control	Vector control			Realsensorless vector control			
								Speed	Torque	Position	Speed	Torque		
Torque limit	810	0A	8A	8	Torque limit input method selection	—	—	✓	—	✓	✓	—	6-70, 6-318	
	811	0B	8B	8	Set resolution switchover	✓	✓	✓	✓	✓	✓	✓	6-70	
	812	0C	8C	8	Torque limit level (regeneration)	—	—	✓	—	✓	✓	—	6-70	
	813	0D	8D	8	Torque limit level (3rd quadrant)	—	—	✓	—	✓	✓	—	6-70	
	814	0E	8E	8	Torque limit level (4th quadrant)	—	—	✓	—	✓	✓	—	6-70	
	815	0F	8F	8	Torque limit level 2	—	—	✓	—	✓	✓	—	6-70	
	816	10	90	8	Torque limit level during acceleration	—	—	✓	—	✓	✓	—	6-70	
	817	11	91	8	Torque limit level during deceleration	—	—	✓	—	✓	✓	—	6-70	
Easy gain tuning	818	12	92	8	Easy gain tuning response level setting	—	—	✓	—	✓	✓	—	6-88	
	819	13	93	8	Easy gain tuning selection	—	—	✓	—	✓	✓	—	6-88	
Adjustment function	820	14	94	8	Speed control P gain 1	—	—	✓	—	✓	✓	—	6-88	
	821	15	95	8	Speed control integral time 1	—	—	✓	—	✓	✓	—	6-88	
	822	16	96	8	Speed setting filter 1	—	—	✓	✓	—	✓	✓	6-380	
	823 <sup>①</sup>	17	97	8	Speed detection filter 1	—	—	✓	✓	✓	—	—	6-144	
	824	18	98	8	Torque control P gain 1	—	—	✓	✓	✓	✓	✓	6-124	
	825	19	99	8	Torque control integral time 1	—	—	✓	✓	✓	✓	✓	6-124	
	826	1A	9A	8	Torque setting filter 1	—	—	✓	✓	✓	✓	✓	6-380	
	827	1B	9B	8	Torque detection filter 1	—	—	✓	✓	✓	✓	✓	6-144	
	828	1C	9C	8	Model speed control gain	—	—	✓	—	✓	✓	—	6-99	
	830	1E	9E	8	Speed control P gain 2	—	—	✓	—	✓	✓	—	6-88	
	831	1F	9F	8	Speed control integral time 2	—	—	✓	—	✓	✓	—	6-88	
	832	20	A0	8	Speed setting filter 2	—	—	✓	✓	—	✓	✓	6-380	
	833 <sup>①</sup>	21	A1	8	Speed detection filter 2	—	—	✓	—	✓	—	—	6-144	
	834	22	A2	8	Torque control P gain 2	—	—	✓	✓	✓	✓	✓	6-124	
	835	23	A3	8	Torque control integral time 2	—	—	✓	✓	✓	✓	✓	6-124	
836	24	A4	8	Torque setting filter 2	—	—	✓	✓	✓	✓	✓	6-380		
837	25	A5	8	Torque detection filter 2	—	—	✓	✓	✓	✓	✓	6-144		
Parameter for option FR-A7AZ (Motor thermistor)	838				DA1 terminal function selection	✓	✓	✓	✓	✓	✓	—		

Tab. A-5: Parameter list with instruction codes (20)

<sup>①</sup> Setting can be made only when the FR-A7AP is mounted.

Function	Parameter	Instruction Code			Name	Control Mode-based Correspondence Table							Refer to Page	Customer Setting
		Read	Write	Extended		V/f Control	Advanced magnetic flux vector control	Vector control			Realsensorless vector control			
								Speed	Torque	Position	Speed	Torque		
Torque bias	840 <sup>①</sup>	28	A8	8	Torque bias selection	—	—	✓	—	—	—	—	6-102	
	841 <sup>①</sup>	29	A9	8	Torque bias 1	—	—	✓	—	—	—	—	6-102	
	842 <sup>①</sup>	2A	AA	8	Torque bias 2	—	—	✓	—	—	—	—	6-102	
	843 <sup>①</sup>	2B	AB	8	Torque bias 3	—	—	✓	—	—	—	—	6-102	
	844 <sup>①</sup>	2C	AC	8	Torque bias filter	—	—	✓	—	—	—	—	6-102	
	845 <sup>①</sup>	2D	AD	8	Torque bias operation time	—	—	✓	—	—	—	—	6-102	
	846 <sup>①</sup>	2E	AE	8	Torque bias balance compensation	—	—	✓	—	—	—	—	6-102	
	847 <sup>①</sup>	2F	AF	8	Fall-time torque bias terminal 1 bias	—	—	✓	—	—	—	—	6-102	
	848 <sup>①</sup>	30	B0	8	Fall-time torque bias terminal 1 gain	—	—	✓	—	—	—	—	6-102	
Additional function	849	31	B1	8	Analog input off set adjustment	✓	✓	✓	✓	✓	✓	✓	6-380	
	850	32	B2	8	Control operation selection	—	—	—	—	—	✓	✓	6-241	
	853	35	B5	8	Speed deviation time	—	—	✓	—	—	—	—	6-107	
	854	36	B6	8	Excitation ratio	—	—	✓	✓	✓	✓	✓	6-146	
	858	3A	BA	8	Terminal 4 function assignment	✓	✓	✓	✓	✓	✓	✓	6-369	
	859	3B	BB	8	Torque current	—	✓	✓	✓	✓	✓	✓	6-222	
	860	3C	BC	8	Second motor torque current	—	✓	—	—	—	✓	✓	6-222	
	862	3E	BE	8	Notch filter time constant	—	—	✓	—	✓	✓	—	6-109	
	863	3F	BF	8	Notch filter depth	—	—	✓	—	✓	✓	—	6-109	
	864	40	C0	8	Torque detection	—	—	✓	✓	✓	✓	✓	6-314	
865	41	C1	8	Low speed detection	—	—	✓	✓	✓	✓	✓	6-309		
Indication function	866	42	C2	8	Torque monitoring reference	—	✓	✓	✓	✓	✓	✓	6-309	
—	867	43	C3	8	AM output filter	✓	✓	✓	✓	✓	✓	✓	6-330	
—	868	44	C4	8	Terminal 1 function assignment	✓	✓	✓	✓	✓	✓	✓	6-369	
—	869	45	C5	8	Current output filter	✓	✓	✓	✓	✓	✓	✓	6-330	
Protective Functions	872	48	C8	8	Input phase failure protection selection	✓	✓	✓	✓	✓	✓	✓	6-356	
	873 <sup>①</sup>	49	C9	8	Speed limit	—	—	✓	—	—	—	—	6-107	
	874	4A	CA	8	OLT level setting	—	—	✓	—	✓	✓	—	6-80	
	875	4B	CB	8	Fault definition	✓	✓	✓	✓	—	✓	✓	6-358	

Tab. A-5: Parameter list with instruction codes (21)

① Setting can be made only when the FR-A7AP is mounted.



Function	Parameter	Instruction Code			Name	Control Mode-based Correspondence Table						Refer to Page	Customer Setting	
		Read	Write	Extended		V/f Control	Advanced magnetic flux vector control	Vector control			Realsensorless vector control			
								Speed	Torque	Position	Speed			Torque
Control system functions	877	4D	CD	8	Speed feed forward control/model adaptive speed control selection	—	—	✓	—	✓	✓	—	6-99	
	878	4E	CE	8	Speed feed forward filter	—	—	✓	—	✓	✓	—	6-99	
	879	4F	CF	8	Speed feed forward torque limit	—	—	✓	—	✓	✓	—	6-99	
	880	50	D0	8	Load inertia ratio	—	—	✓	—	✓	✓	—	6-99	
	881	51	D1	8	Speed feed forward gain	—	—	✓	—	✓	✓	—	6-99	
Regeneration avoidance function	882	52	D2	8	Regeneration avoidance operation selection	✓	✓	✓	—	—	✓	—	6-523	
	883	53	D3	8	Regeneration avoidance operation level	✓	✓	✓	—	—	✓	—	6-523	
	884	54	D4	8	Regeneration avoidance at deceleration detection sensitivity	✓	✓	✓	—	—	✓	—	6-523	
	885	55	D5	8	Regeneration avoidance compensation frequency limit value	✓	✓	✓	—	—	✓	—	6-523	
	886	56	D6	8	Regeneration avoidance voltage gain	✓	✓	✓	—	—	✓	—	6-523	
Free parameter	888	58	D8	8	Free parameter 1	✓	✓	✓	✓	✓	✓	✓	6-536	
	889	59	D9	8	Free parameter 2	✓	✓	✓	✓	✓	✓	✓	6-536	
Energy saving monitor	891	5B	DB	8	Cumulative power monitor digit shifted times	✓	✓	✓	✓	✓	✓	✓	6-360	
	892	5C	DC	8	Load factor	✓	✓	✓	✓	✓	✓	✓	6-360	
	893	5D	DD	8	Energy saving monitor reference (motor capacity)	✓	✓	✓	✓	✓	✓	✓	6-360	
	894	5E	DE	8	Auswahl des Regelverhaltens	✓	✓	✓	✓	✓	✓	✓	6-360	
	895	5F	DF	8	Power saving rate reference value	✓	✓	✓	✓	✓	✓	✓	6-360	
	896	60	E0	8	Power unit cost	✓	✓	✓	✓	✓	✓	✓	6-360	
	897	61	E1	8	Power saving monitor average time	✓	✓	✓	✓	✓	✓	✓	6-360	
	898	62	E2	8	Power saving cumulative monitor clear	✓	✓	✓	✓	✓	✓	✓	6-360	
	899	63	E3	8	Operation time rate (estimated value)	✓	✓	✓	✓	✓	✓	✓	6-360	

Tab. A-5: Parameter list with instruction codes (22)

Function	Parameter	Instruction Code			Name	Control Mode-based Correspondence Table						Refer to Page	Customer Setting	
		Read	Write	Extended		V/f Control	Advanced magnetic flux vector control	Vector control			Realsensorless vector control			
								Speed	Torque	Position	Speed			Torque
Calibration parameters	<b>C0 (900)</b>	5C	DC	1	CA terminal calibration	✓	✓	✓	✓	✓	✓	6-333		
	<b>C1 (901)</b>	5D	DD	1	AM terminal calibration	✓	✓	✓	✓	✓	✓	6-333		
	<b>C2 (902)</b>	5E	DE	1	Terminal 2 frequency setting bias frequency	✓	✓	✓	✓	✓	✓	6-382		
	<b>C3 (902)</b>	5E	DE	1	Terminal 2 frequency setting bias	✓	✓	✓	✓	✓	✓	6-382		
	<b>125 (903)</b>	5F	DF	1	Terminal 2 frequency setting gain frequency	✓	✓	✓	✓	✓	✓	6-382		
	<b>C4 (903)</b>	5F	DF	1	Terminal 2 frequency setting gain	✓	✓	✓	✓	✓	✓	6-382		
	<b>C5 (904)</b>	60	E0	1	Terminal 4 frequency setting bias frequency	✓	✓	✓	✓	✓	✓	6-382		
	<b>C6 (904)</b>	60	E0	1	Terminal 4 frequency setting bias	✓	✓	✓	✓	✓	✓	6-382		
	<b>126 (905)</b>	61	E1	1	Terminal 4 frequency setting gain frequency	✓	✓	✓	✓	✓	✓	6-382		
	<b>C7 (905)</b>	61	E1	1	Terminal 4 frequency setting gain	✓	✓	✓	✓	✓	✓	6-382		
Analog output current calibration	<b>C8 (930)</b>	1E	9E	9	Current output bias signal	✓	✓	✓	✓	✓	✓	6-333		
	<b>C9 (930)</b>	1E	9E	9	Current output bias current	✓	✓	✓	✓	✓	✓	6-333		
	<b>C10 (931)</b>	1F	9F	9	Current output gain signal	✓	✓	✓	✓	✓	✓	6-333		
	<b>C11 (931)</b>	1F	9F	9	Current output gain current	✓	✓	✓	✓	✓	✓	6-333		
Calibration parameters	<b>C12 (917)</b>	11	91	9	Terminal 1 bias frequency (speed)	—	—	✓	✓	✓	✓	6-382		
	<b>C13 (917)</b>	11	91	9	Terminal 1 bias (speed)	—	—	✓	✓	✓	✓	6-382		
	<b>C14 (918)</b>	12	92	9	Terminal 1 gain frequency (speed)	—	—	✓	✓	✓	✓	6-382		
	<b>C15 (918)</b>	12	92	9	Terminal 1 gain (speed)	—	—	✓	✓	✓	✓	6-382		
	<b>C16 (919)</b>	13	93	9	Terminal 1 bias command (torque/magnetic flux)	—	—	✓	✓	✓	✓	6-391		
	<b>C17 (919)</b>	13	93	9	Terminal 1 bias (torque/magnetic flux)	—	—	✓	✓	✓	✓	6-391		
	<b>C18 (920)</b>	14	94	9	Terminal 1 gain command (torque/magnetic flux)	—	—	✓	✓	✓	✓	6-391		
	<b>C19 (920)</b>	14	94	9	Terminal 1 gain (torque/magnetic flux)	—	—	✓	✓	✓	✓	6-391		
	<b>C38 (932)</b>	20	A0	9	Terminal 4 bias command (torque/magnetic flux)	—	—	✓	✓	✓	✓	6-391		
	<b>C39 (932)</b>	20	A0	9	Terminal 4 bias (torque/magnetic flux)	—	—	✓	✓	✓	✓	6-391		

Tab. A-5: Parameter list with instruction codes (23)

Function	Parameter	Instruction Code			Name	Control Mode-based Correspondence Table							Refer to Page	Customer Setting
		Read	Write	Extended		V/f Control	Advanced magnetic flux vector control	Vector control			Realsensorless vector control			
								Speed	Torque	Position	Speed	Torque		
Calibration parameters	<b>C40 (933)</b>	21	A1	9	Terminal 4 gain command (torque/magnetic flux)	—	—	✓	✓	✓	✓	✓	6-391	
	<b>C41 (933)</b>	21	A1	9	Terminal 4 gain (torque/magnetic flux)	—	—	✓	✓	✓	✓	✓	6-391	
—	<b>989</b>	59	D9	9	Parameter copy alarm release	✓	✓	✓	✓	✓	✓	✓	—	
PU	<b>990</b>	5A	DA	9	PU buzzer control	✓	✓	✓	✓	✓	✓	✓	6-538	
	<b>© 991</b>	5B	DB	9	PU contrast adjustment	✓	✓	✓	✓	✓	✓	✓	6-538	

**Tab. A-5:** Parameter list with instruction codes (24)



# Index

## A

AC reactor	3-55
Acceleration	
Characteristic	6-201
Acceleration and deceleration time	
Parameter	6-195
Advanced magnetic flux vector control	6-65
Parameter	6-150
Alarm code	
Output	6-358
Alarm history	
clear	7-25
read	7-25
Alarm output	
code	6-358
Terminals	3-22
AM output	3-23
Auto tuning	
Offline	6-222
Online	6-236
Automatic restart	6-340

## B

Base frequency	6-172
Basic settings	5-1
Bias	
adjust	6-385
Buzzer	
control	6-542

## C

CA output	3-23
Cables	
Size	3-12
Calibration	
Terminal CA, AM	6-336
Case	1-2
Characteristic	
Acceleration/deceleration	6-201
Load torque	6-175
Cleaning	8-8
Combined operation mode	6-423
Communication	
Basic settings	6-448
Mitsubishi inverter protocol	6-451
Modbus-RTU	6-470

PU connector	6-440
RS-485 terminal	6-443
USB	6-490
Connection	
external brake resistor	3-45
Motor with encoder	3-34
USB connector	3-33
Contactors and breakers	3-3
Contrast	
Parameter	6-542
Control codes	6-454
Control modes	6-65
Cooling	2-9
Cooling fan	
Operation	6-530
Reinstallation	8-11
Removal	8-10
Cooling system	2-9
Cumulative power meter	
clear	6-324

## D

DC injection brake	
Parameter	6-241
DC reactor	3-55
Digital dial	4-5
Dimensions	
DC reactor	A-18
Inverter	A-7
Operation panel FR-DU07	A-24
Parameter unit FR-PU04	A-25
Display	
I/O terminals	6-330
Selection	6-324
Speed	6-321
Droop control	6-516

<b>E</b>		<b>L</b>	
Earthing		Language selection	
Leakage currents	3-14	Parameter	6-541
Electromagnetic compatibility	3-56	Leakage currents	3-56
Elevator mode	6-178	Life	
EMC filter	3-64	Monitor	6-531
Enclosure		Load pattern	
Cooling system	2-9	Selection	6-175
Design	2-6	Load torque	
Encoder feedback control	6-521	Selection	6-166
Energy saving control	6-362	Load torque high speed frequency control	6-512
Energy saving monitor	6-363	Logic	
Environment specifications	2-6	Sink logic	3-24
Error		Source logic	3-24
corrective action	7-5		
Diagnosis	7-1	<b>M</b>	
Display	7-5	Magnetic flux decay output shutoff function	6-246
LED/LCD display	7-2	Maintenance	8-1
List	7-2	Maintenance timer	
Message	7-2	Parameter	6-535
Troubleshooting	7-27	Mechanical brake	
		Control	6-264
<b>F</b>		Mitsubishi inverter protocol	6-451
Feed forward control		Motor	
Speed	6-99	Commercial power supply switchover	6-505
Frequency jump		Selection	6-218
Parameter	6-170	Motor protection	
Frequency monitor		Parameter	6-212
Reference	6-333	PTC thermistor	6-217
Frequency setting		Multi-speed setting	
Digital dial	5-42	Parameter	6-183
Front cover		<b>O</b>	
Reinstallation	2-2	Operation hour meter	
Removal	2-2	clear	6-324
		Operation mode	
<b>G</b>		at power on	6-430
Gain		combined	6-423
adjust	6-385	Communication	6-434
		external operation	6-422
<b>I</b>		PU operation mode	6-423
Input terminals		Operation mode selection	
Function selection	6-289	Flow chart	6-421
Inspection	8-1	Parameter	6-418
Installation		Operation panel	
Enclosure	2-5	Basic functions	4-6
Instruction codes	A-26	Functions	4-4
Insulation resistance test	8-15	Reinstallation	2-1
		Removal	2-1
<b>J</b>		Wiring	3-30
Jog operation		Output	
Parameter	6-186	analog	6-333

Output current	
Detection	6-315
Output frequency	
Detection	6-312
Frequency jumps	6-170
Jog frequency	6-186
maximum	6-168
minimum	6-168
Multi-speed setting	6-183
Starting frequency	6-199
Output terminals	
Function selection	6-301
Output torque detection	6-317
Overspeed detection	6-360

**P**

Parameter	
all clear	4-12
clear	4-11
copy	4-14
free	6-540
Instruction codes	A-26
Overview	6-1
Simple mode parameters	5-1
verify	4-16
Parameter write disable	6-411
PID control	
Parameter	6-491
PLC	
Connection	3-26
PLC function	6-489
Position feed forward gain	6-141
Protective earth	
Wiring	3-7
Protective functions	
Alarm code	6-358
Overview	A-6
reset	7-23
PTC thermistor	
Connection	6-217
Pulse train input	6-518

**R**

Reactor	3-55
Real sensorless vector control	6-65
Regeneration avoidance	
Parameter	6-527
Regenerative mode	
Output signal	6-310
Remote outputs	
Parameter	6-318
Remote setting function	
Parameter	6-191

Reset	7-23
Resonance points	
Avoidance	6-170
Restart	
at alarm occurrence	6-354
at power failure	6-342
Reverse rotation prevention	
Parameter	6-414

**S**

Second functions	
Setting	6-295
Serial number	1-2
Set value	
adjust	6-385
analog	6-374
Bias	6-391
Filter	6-383
Gain	6-391
Torque setting bias	6-400
Torque setting gain	6-400
Shortest acceleration/deceleration	6-208
Simple mode parameters	5-1
Specifications	A-1
Speed display	
Parameter	6-321
Stall prevention	
Parameter	6-155
Start signal	
Assignment	6-297
Starting frequency	
DC injection brake	6-242
Parameter	6-199
Starting the inverter	4-3
Station number	6-448
Stop-on contact control	6-259

**T**

Terminal	
Control circuit	3-19
Terminals	
Communication	3-23
Function assignment	6-289
Torque	
Boost	6-147
Parameter	6-147
Traverse function	6-524

**U**

Up-to-frequency sensitivity	
Parameter .....	6-312
USB connector .....	6-490
User group	
Parameter deletion .....	6-417
User groups	
Parameter .....	6-415

**V**

V/f control .....	6-65
V/f pattern	
Parameter .....	6-172
Vector control .....	6-65

**W**

Wiring	
Control circuit .....	3-19
DC reactor .....	3-55
External brake unit .....	3-48
High power factor converter .....	3-51
Magnetic contactor .....	3-43
Main circuit .....	3-7
Operation panel .....	3-30
Power regeneration common converter ..	3-53
Reactor .....	3-55
RS-485 terminal block .....	3-31
Stand-alone option units .....	3-43
System configuration .....	3-1
Terminal connection diagram .....	3-5
Wiring cover .....	3-11

**Z**

Zero current	
Detection .....	6-316





**HEADQUARTERS**

MITSUBISHI ELECTRIC EUROPE B.V. **EUROPE**  
 German Branch  
 Gothaer Straße 8  
**D-40880 Ratingen**  
 Phone: +49 (0)2102 / 486-0  
 Fax: +49 (0)2102 / 486-1120

MITSUBISHI ELECTRIC EUROPE B.V.-org.sl. **CZECH REP.**  
 Czech Branch  
 Avenir Business Park, Radlická 714/113a  
**CZ-158 00 Praha 5**  
 Phone: +420 - 251 551 470  
 Fax: +420 - 251-551-471

MITSUBISHI ELECTRIC EUROPE B.V. **FRANCE**  
 French Branch  
 25, Boulevard des Bouvets  
**F-92741 Nanterre Cedex**  
 Phone: +33 (0)1 / 55 68 55 68  
 Fax: +33 (0)1 / 55 68 57 57

MITSUBISHI ELECTRIC EUROPE B.V. **IRELAND**  
 Irish Branch  
 Westgate Business Park, Ballymount  
**IRL-Dublin 24**  
 Phone: +353 (0)1 4198800  
 Fax: +353 (0)1 4198890

MITSUBISHI ELECTRIC EUROPE B.V. **ITALY**  
 Italian Branch  
 Viale Colleoni 7  
**I-20041 Agrate Brianza (MB)**  
 Phone: +39 039 / 60 53 1  
 Fax: +39 039 / 60 53 312

MITSUBISHI ELECTRIC EUROPE B.V. **POLAND**  
 Poland Branch  
 Krakowska 50  
**PL-32-083 Balice**  
 Phone: +48 (0)12 / 630 47 00  
 Fax: +48 (0)12 / 630 47 01

MITSUBISHI ELECTRIC EUROPE B.V. **RUSSIA**  
 52, bid. 3 Kosmodamienskaya nab 8 floor  
**RU-115054 Moscow**  
 Phone: +7 495 721-2070  
 Fax: +7 495 721-2071

MITSUBISHI ELECTRIC EUROPE B.V. **SPAIN**  
 Spanish Branch  
 Carretera de Rubí 76-80  
**E-08190 Sant Cugat del Vallés (Barcelona)**  
 Phone: 902 131121 // +34 935653131  
 Fax: +34 935891579

MITSUBISHI ELECTRIC EUROPE B.V. **UK**  
 UK Branch  
 Travellers Lane  
**UK-Hatfield, Herts. AL10 8XB**  
 Phone: +44 (0)1707 / 27 61 00  
 Fax: +44 (0)1707 / 27 86 95

MITSUBISHI ELECTRIC CORPORATION **JAPAN**  
 Office Tower "Z" 14 F  
 8-12,1 chome, Harumi Chuo-Ku  
**Tokyo 104-6212**  
 Phone: +81 3 622 160 60  
 Fax: +81 3 622 160 75

MITSUBISHI ELECTRIC AUTOMATION, Inc. **USA**  
 500 Corporate Woods Parkway  
**Vernon Hills, IL 60061**  
 Phone: +1 847 478 21 00  
 Fax: +1 847 478 22 53

**EUROPEAN REPRESENTATIVES**

GEVA **AUSTRIA**  
 Wiener Straße 89  
**AT-2500 Baden**  
 Phone: +43 (0)2252 / 85 55 20  
 Fax: +43 (0)2252 / 488 60

TECHNIKON **BELARUS**  
 Oktyabrskaya 19, Off. 705  
**BY-220030 Minsk**  
 Phone: +375 (0)17 / 210 46 26  
 Fax: +375 (0)17 / 210 46 26

ESCO DRIVES & AUTOMATION **BELGIUM**  
 Culliganlaan 3  
**BE-1831 Diegem**  
 Phone: +32 (0)2 / 717 64 30  
 Fax: +32 (0)2 / 717 64 31

Koning & Hartman b.v. **BELGIUM**  
 Woluwelaan 31  
**BE-1800 Vilvoorde**  
 Phone: +32 (0)2 / 257 02 40  
 Fax: +32 (0)2 / 257 02 49

INEA RBT d.o.o. **BOSNIA AND HERZEGOVINA**  
 Aleja Lipa 56  
**BA-71000 Sarajevo**  
 Phone: +387 (0)33 / 921 164  
 Fax: +387 (0)33 / 524 539

AKHNATON **BULGARIA**  
 4, Andrei Ljapchev Blvd., PO Box 21  
**BG-1756 Sofia**  
 Phone: +359 (0)2 / 817 6000  
 Fax: +359 (0)2 / 97 44 06 1

INEA RBT d.o.o. **CROATIA**  
 Losinjska 4 a  
**HR-10000 Zagreb**  
 Phone: +385 (0)1 / 36 940 - 01 / -02 / -03  
 Fax: +385 (0)1 / 36 940 - 03

AutoCont C.S. s.r.o. **CZECH REPUBLIC**  
 Technologická 374/6  
**CZ-708 00 Ostrava-Pustkovce**  
 Phone: +420 595 691 150  
 Fax: +420 595 691 199

Beijer Electronics A/S **DENMARK**  
 Lykkegårdsvej 17  
**DK-4000 Roskilde**  
 Phone: +45 (0)46 / 75 76 66  
 Fax: +45 (0)46 / 75 56 26

Beijer Electronics Eesti OÜ **ESTONIA**  
 Pärnu mnt.160i  
**EE-11317 Tallinn**  
 Phone: +372 (0)6 / 51 81 40  
 Fax: +372 (0)6 / 51 81 49

Beijer Electronics OY **FINLAND**  
 Peltoie 37  
**FIN-28400 Ulvila**  
 Phone: +358 (0)207 / 463 540  
 Fax: +358 (0)207 / 463 541

UTEKO **GREECE**  
 5, Mavrogenou Str.  
**GR-18542 Piraeus**  
 Phone: +30 211 / 1206 900  
 Fax: +30 211 / 1206 999

MELTRADE Kft. **HUNGARY**  
 Fertő utca 14.  
**HU-1107 Budapest**  
 Phone: +36 (0)1 / 431-9726  
 Fax: +36 (0)1 / 431-9727

Beijer Electronics SIA **LATVIA**  
 Rītausmas iela 23  
**LV-1058 Rīga**  
 Phone: +371 (0)784 / 2280  
 Fax: +371 (0)784 / 2281

Beijer Electronics UAB **LITHUANIA**  
 Savanoriu Pr. 187  
**LT-02300 Vilnius**  
 Phone: +370 (0)5 / 232 3101  
 Fax: +370 (0)5 / 232 2980

**EUROPEAN REPRESENTATIVES**

ALFATRADA Ltd. **MALTA**  
 99, Paola Hill  
**Malta- Paola PLA 1702**  
 Phone: +356 (0)21 / 697 816  
 Fax: +356 (0)21 / 697 817

INTEHSIS srl **MOLDOVA**  
 bld. Traian 23/1  
**MD-2060 Kishinev**  
 Phone: +373 (0)22 / 66 4242  
 Fax: +373 (0)22 / 66 4280

HIFLEX AUTOM.TECHNIEK B.V. **NETHERLANDS**  
 Wolveverstraat 22  
**NL-2984 CD Ridderkerk**  
 Phone: +31 (0)180 - 46 60 04  
 Fax: +31 (0)180 - 44 23 55

Koning & Hartman b.v. **NETHERLANDS**  
 Haarlbergweg 21-23  
**NL-1101 CH Amsterdam**  
 Phone: +31 (0)20 / 587 76 00  
 Fax: +31 (0)20 / 587 76 05

Beijer Electronics AS **NORWAY**  
 Postboks 487  
**NO-3002 Drammen**  
 Phone: +47 (0)32 / 24 30 00  
 Fax: +47 (0)32 / 84 85 77

Fonseca S.A. **PORTUGAL**  
 R. João Francisco do Casal 87/89  
**PT - 3801-997 Aveiro, Esgueira**  
 Phone: +351 (0)234 / 303 900  
 Fax: +351 (0)234 / 303 910

Sirius Trading & Services srl **ROMANIA**  
 Aleea Lacul Morii Nr. 3  
**RO-060841 Bucuresti, Sector 6**  
 Phone: +40 (0)21 / 430 40 06  
 Fax: +40 (0)21 / 430 40 02

INEA RBT d.o.o. **SERBIA**  
 Izletnicka 10  
**SER-113000 Smederevo**  
 Phone: +381 (0)26 / 615 401  
 Fax: +381 (0)26 / 615 401

SIMAP s.r.o. **SLOVAKIA**  
 Jána Derku 1671  
**SK-911 01 Trenčín**  
 Phone: +421 (0)32 743 04 72  
 Fax: +421 (0)32 743 75 20

PROCONT, spol. s r.o. Prešov **SLOVAKIA**  
 Kúpeľná 1/A  
**SK-080 01 Prešov**  
 Phone: +421 (0)51 7580 611  
 Fax: +421 (0)51 7580 650

INEA RBT d.o.o. **SLOVENIA**  
 Stegne 11  
**SI-1000 Ljubljana**  
 Phone: +386 (0)1 / 513 8116  
 Fax: +386 (0)1 / 513 8170

Beijer Electronics AB **SWEDEN**  
 Box 426  
**SE-20124 Malmö**  
 Phone: +46 (0)40 / 35 86 00  
 Fax: +46 (0)40 / 93 23 01

Omni Ray AG **SWITZERLAND**  
 Im Schörl 5  
**CH-8600 Dübendorf**  
 Phone: +41 (0)44 / 802 28 80  
 Fax: +41 (0)44 / 802 28 28

GTS **TURKEY**  
 Bayraktar Bulvarı Nutuk Sok. No:5  
**TR-34775 Yukarı Dudullu-Ümraniye-İSTANBUL**  
 Phone: +90 (0)216 526 39 90  
 Fax: +90 (0)216 526 3995

CSC Automation Ltd. **UKRAINE**  
 4-B, M. Raskovoyi St.  
**UA-02660 Kiev**  
 Phone: +380 (0)44 / 494 33 55  
 Fax: +380 (0)44 / 494-33-66

Systemgroup **UKRAINE**  
 2 M. Krivonosy St.  
**UA-03680 Kiev**  
 Phone: +380 (0)44 / 490 92 29  
 Fax: +380 (0)44 / 248 88 68

**EURASIAN REPRESENTATIVES**

TOO Kazpromavtomatika **KAZAKHSTAN**  
 Ul. Zhambyla 28  
**KAZ-100017 Karaganda**  
 Phone: +7 7212 / 50 10 00  
 Fax: +7 7212 / 50 11 50

**MIDDLE EAST REPRESENTATIVE**

SHERF Motion Techn. Ltd. **ISRAEL**  
 Rehov Hamerkava 19  
**IL-58851 Holon**  
 Phone: +972 (0)3 / 559 54 62  
 Fax: +972 (0)3 / 556 01 82

CEG INTERNATIONAL **LEBANON**  
 Cebaco Center/Block A Autostrade DORA  
**Lebanon - Beirut**  
 Phone: +961 (0)1 / 240 430  
 Fax: +961 (0)1 / 240 438

**AFRICAN REPRESENTATIVE**

CBI Ltd. **SOUTH AFRICA**  
 Private Bag 2016  
**ZA-1600 Isando**  
 Phone: +27 (0)11 / 977 0770  
 Fax: +27 (0)11 / 977 0761