

CMG

transmission

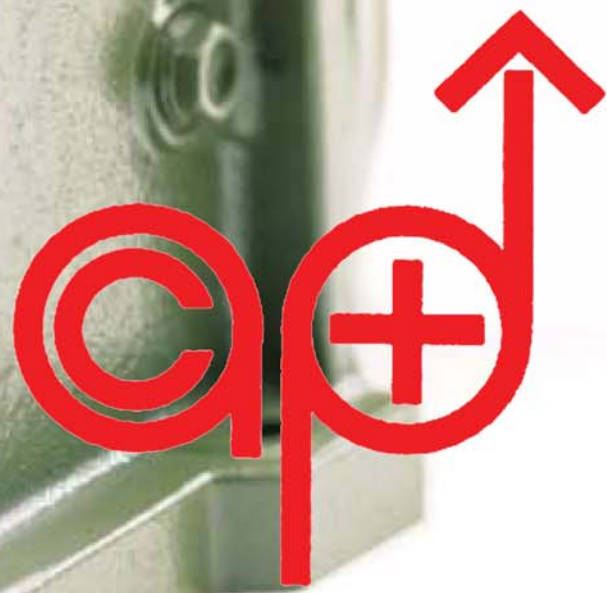

ACP&D Limited

FRC-SGA geared motors

Cast iron inline helical units



The FRC inline geared motor units demonstrate the diversity and outstanding product performance that has built the CMG name. The FRC series ranges up to 2500Nm, 0.55 to 22kW, in rugged cast iron.

CMG's world best practices and technologies, plus our national computerised sales, spare parts and service back-up mean we can offer a total commitment to every customer.

You can be sure every product supplied by CMG's Motors, Transmission or Drives divisions... be it an electric motor, geared motor, variable frequency drive, soft starter, or one of our many other associated products...will perform exactly to specification, and deliver reliable performance year after year with minimum maintenance and downtime.

CMG's Technology division is a recognised R & D leader offering professional engineering staff and facilities for design, testing, product development and quality control.

As depicted in our new corporate identity, when you think Motors, Transmission, Drives, or research and development Technology...think CMG.



FRC-SGA helical geared motors

0.55 to 22 kW, up to 2500 Nm

This is the CMG short form catalogue for the CMG range of FRC-SGA geared motors.

For further detailed information please refer to the nearest CMG office for separate FRC gearbox and SGA motor catalogues.

This partnership of two proven products combines our cast iron FRC gearbox with our cast iron SGA motor, providing a rugged and reliably finished product. After assembly of the two components all FRC-SGA geared motors are test run and painted with a final coat of high quality green enamel.

FRC gearbox

The CMG Varvel range of inline type FRC gearboxes are designed and manufactured to international standards. They are conservatively rated and are suitable for all general applications. Gearbox housings and covers are manufactured in G20-G25 cast iron. Output shafts are manufactured from C43 carbon steel and finished to a tolerance of k6.

Gears are designed and verified to ISO336. They are produced from alloy steel 16 CrN14 or 20 MnCr5, case hardened and tempered with the primary set being shaved before hardening to give quiet running.

Bearings are of ball and roller type and are designed for an average life time of at least 15,000 running hours.

FRC type gearboxes are delivered filled with ISOVG320 grade lubricant. Sizes 10, 20 and 30 are filled with synthetic long life oil (no plugs). Sizes 40, 50 and 60 are filled with mineral oil (with plugs).

This catalogue details the standard foot and flange mounted ranges. Dimensions of alternative free input shaft arrangements and flanges are available on request.

SGA motor

The CMG enhanced performance SGA range of motors are recognised for their inherent suitability for all geared motor applications.

Standard motors are 3 phase, 415 volt, 50 Hz.

Motors are manufactured with 'F' class insulation, with windings designed to limit the temperature rise to 80K.

The SGA motor has an all cast iron construction, and provides a protection rating of IP55 for both motor and terminal box.

Models listed in this catalogue are standard B5 flange mount, 4 pole (1500 r/min) with other motor speeds available upon request.

Also available is the CMG-SGA range of enhanced protection motors (Exe, Exn, DIP), brake and multi speed motors as well as motors built to customer specifications.

Product code specification

When placing an order the gearbox product code, mounting arrangement (see page 7), and motor kW rating should be specified. The product code of the gearbox is composed in accordance with the following example.

V	R	C	3	6	0	4	3	2	0	8	0	S
1-3	4	5-6	7-9	10-12	13							

Positions 1 to 3

Series

VRC= CMG Varvel FRC inline type gearbox

Position 4

Number of stages

Positions 5 and 6

Gearbox size

(10, 20, 30, 40, 50, or 60)

Positions 7 to 9¹⁾

Gearbox ratio

¹⁾ Below ratios of 10, Gearbox ratio x 10 with four characters used.

Positions 10 to 12

Gearbox input size (IEC) (080, 090, 100, 112, 132, 160 or 180)

Position 13

Mounting type

S = Foot mount

F = Flange mount

Service factors

Where the required service factor is not known it can be calculated using the following formula and tables.

Service factor SF = F₁ x F₂

F ₁ selection				F ₂ selection	
Hours per day	Uniform load	Variable load	Shock load	Starts per hour	F ₂
3 to 4	0.8	1.0	1.5	6	1.0
8 to 10	1.0	1.2	1.8	60	1.2
10 to 24	1.4	1.6	2.0	120	1.4

Selection data

Type	r/min	Nm	SF	Ratio	Gearbox code
0.55kW Motor SGA80A-4 B5 code M34000555SGA					
1410 r/min 1.4 Amps					
FRC360-80	3.0	1650	1.5	432	VRC360432080•
	3.5	1410	1.8	388	VRC360388080•
FRC350-80	4.5	1100	1.1	320	VRC350320080•
	5.0	990	1.3	284	VRC350284080•
	5.5	900	1.4	254	VRC350254080•
	6.5	760	1.6	208	VRC350208080•
	8.0	620	2.0	174	VRC350174080•
	FRC340-80	9.5	520	1.2	147
10.5		470	1.3	133	VRC340133080•
12.0		410	1.5	119	VRC340119080•
13.5		365	1.6	103	VRC340103080•
16		310	1.9	87	VRC340087080•
FRC330-80		19	260	1.2	73
	23	215	1.4	61	VRC330061080•
FRC230-80	27	190	1.6	52	VRC230052080•
	31	165	1.8	46	VRC230046080•
FRC220-80	37	135	1.1	38	VRC220038080•
	42	120	1.2	34	VRC220034080•
	47	110	1.4	30	VRC220030080•
	57	90	1.7	25	VRC220025080•
	69	75	2.0	20	VRC220020080•
	82	60	2.5	18	VRC220018080•
FRC210-80	90	55	1.3	16	VRC210016080•
	101	50	1.5	14	VRC210014080•
	113	45	1.7	13	VRC210013080•
	138	36	2.1	10	VRC210010080•
	166	30	2.5	8.7	VRC2100087080•
FRC120-80	175	29	1.4	8.3	VRC1200083080•
FRC210-80	196	26	2.9	7.3	VRC2100073080•
	210	24	>3	6.8	VRC2100068080•
	230	22	>3	6.3	VRC2100063080•
	240	21	>3	6.0	VRC2100060080•
	268	19	>3	5.4	VRC2100054080•
	324	16	>3	4.5	VRC2100045080•
	388	13	>3	3.7	VRC2100037080•
	FRC110-80	415	12	1.6	3.5
FRC210-80	460	11	>3	3.1	VRC2100031080•
	540	9.3	>3	2.7	VRC2100027080•
	630	8.0	>3	2.3	VRC2100023080•
FRC110-80	965	5.3	>3	1.5	VRC1100015080•
0.75kW Motor SGA80B-4 B5 code M34000755SGA					
1400 r/min 1.9 Amps					
FRC360-80	3.0	2245	1.0	432	VRC360432080•
	3.5	1925	1.2	388	VRC360388080•
	4.5	1500	1.7	320	VRC360320080•
	5.0	1350	1.9	284	VRC360284080•
	5.5	1225	2.0	254	VRC360254080•
FRC350-80	6.5	1035	1.2	208	VRC350208080•
	8.0	840	1.5	174	VRC350174080•
	9.5	710	1.8	147	VRC350147080•
	10.5	640	1.9	133	VRC350133080•
FRC340-80	12.0	560	1.1	119	VRC340119080•
	13.5	500	1.2	103	VRC340103080•
	16	420	1.4	87	VRC340087080•
	19	355	1.7	73	VRC340073080•
	23	295	2.1	61	VRC340061080•

• = Mounting: S = Foot mount, F = Flange mount

Type	r/min	Nm	SF	Ratio	Gearbox code	
0.75kW Motor SGA80B-4 B5 code M34000755SGA						
1400 r/min 1.9 Amps						
FRC230-80	27	255	1.2	52	VRC230052080•	
	31	220	1.4	46	VRC230046080•	
	37	185	1.6	38	VRC230038080•	
	42	165	1.8	34	VRC230034080•	
FRC220-80	47	145	1.0	30	VRC220030080•	
	57	120	1.2	25	VRC220025080•	
	69	100	1.5	20	VRC220020080•	
	82	85	1.8	18	VRC220018080•	
	90	75	2.0	16	VRC220016080•	
	101	70	2.2	14	VRC220014080•	
	113	60	2.5	13	VRC220013080•	
	138	50	3.0	10	VRC220010080•	
FRC210-80	166	41	1.8	8.7	VRC2100087080•	
FRC120-80	175	40	1.0	8.3	VRC1200083080•	
FRC210-80	196	35	2.1	7.3	VRC2100073080•	
	210	33	2.3	6.8	VRC2100068080•	
	230	30	2.5	6.3	VRC2100063080•	
	240	26	2.9	6.0	VRC2100060080•	
	268	26	>3	5.4	VRC2100054080•	
	324	21	>3	4.5	VRC2100045080•	
	388	18	>3	3.7	VRC2100037080•	
	FRC110-80	415	17	1.2	3.5	VRC1100035080•
FRC210-80	460	15	>3	3.1	VRC2100031080•	
	540	13	>3	2.7	VRC2100027080•	
	630	11	>3	2.3	VRC2100023080•	
FRC110-80	965	7.3	2.7	1.5	VRC1100015080•	
1.1kW Motor SGA90S-4 B5 code M34001105SGA						
1415r/min 2.5 Amps						
FRC360-90S	4.5	2195	1.1	320	VRC360320090•	
	5.0	1975	1.3	284	VRC360284090•	
	5.5	1795	1.4	254	VRC360254090•	
	6.5	1520	1.6	208	VRC360208090•	
	8.0	1235	2.0	174	VRC360174090•	
FRC350-90S	9.5	1040	1.2	147	VRC350147090•	
	10.5	940	1.3	133	VRC350133090•	
	12.0	825	1.5	119	VRC350119090•	
	13.5	730	1.7	103	VRC350103090•	
	16	620	2.0	87	VRC350087090•	
FRC340-90S	19	520	1.2	73	VRC340073090•	
	23	430	1.4	61	VRC340061090•	
FRC240-90S	27	375	1.6	52	VRC240052090•	
	31	325	1.8	46	VRC240046090•	
FRC230-90S	37	275	1.1	38	VRC230038090•	
	42	240	1.2	34	VRC230034090•	
	47	215	1.4	30	VRC230030090•	
	57	180	1.7	25	VRC230025090•	
	69	145	2.0	20	VRC230020090•	
	82	125	2.4	18	VRC230018090•	
	FRC220-90S	90	115	1.3	16	VRC220016090•
		101	100	1.5	14	VRC220014090•
113		90	1.7	13	VRC220013090•	
138		75	2.0	10	VRC220010090•	
166		60	2.5	8.7	VRC2200087090•	
FRC130-90S		175	60	1.4	8.3	VRC1300083090•

Type	r/min	Nm	SF	Ratio	Gearbox code
1.1kW	Motor SGA90S-4 B5 code M34001105SGA				
	1415r/min	2.5 Amps			
FRC220-90S	196	50	2.9	7.3	VRC2200073090•
	210	48	>3	6.8	VRC2200068090•
	230	44	>3	6.3	VRC2200063090•
	240	42	>3	6.0	VRC2200060090•
	268	38	>3	5.4	VRC2200054090•
	324	31	>3	4.5	VRC2200045090•
	388	26	>3	3.7	VRC2200037090•
FRC120-90S	415	25	1.7	3.5	VRC1200035090•
FRC220-90S	460	22	>3	3.1	VRC2200031090•
	540	19	>3	2.7	VRC2200027090•
	630	16	>3	2.3	VRC2200023090•
FRC120-90S	965	11	>3	1.5	VRC1200015090•

Type	r/min	Nm	SF	Ratio	Gearbox code
1.5kW	Motor SGA90L-4 B5 code M34001505SGA				
	1395 r/min	3.2 Amps			
FRC360-90L	6.5	2070	1.2	208	VRC360208090•
	8.0	1685	1.5	174	VRC360174090•
	9.5	1420	1.8	147	VRC360147090•
FRC350-90L	10.5	1285	1.0	133	VRC350133090•
	12.0	1125	1.1	119	VRC350119090•
	13.5	1000	1.3	103	VRC350103090•
	16	840	1.5	87	VRC350087090•
	19	700	1.8	73	VRC350073090•
	23	585	2.1	61	VRC350061090•
FRC240-90L	27	510	1.2	52	VRC240052090•
	31	445	1.4	46	VRC240046090•
	37	370	1.6	38	VRC240038090•
	42	330	1.8	34	VRC240034090•
FRC230-90L	47	300	1.0	30	VRC230030090•
	57	240	1.2	25	VRC230025090•
	69	200	1.5	20	VRC230020090•
	82	170	1.8	18	VRC230018090•
	90	155	2.0	16	VRC230016090•
	101	135	2.2	14	VRC230014090•
	113	120	2.5	13	VRC230013090•
	138	100	3.0	10	VRC230010090•
FRC220-90L	166	85	1.8	8.7	VRC2200087090•
FRC130-90L	175	80	1.0	8.3	VRC1300083090•
FRC220-90L	196	70	2.1	7.3	VRC2200073090•
	210	65	2.3	6.8	VRC2200068090•
	230	60	2.5	6.3	VRC2200063090•
	240	55	2.6	6.0	VRC2200060090•
	268	50	3.0	5.4	VRC2200054090•
	324	42	>3	4.5	VRC2200045090•
	388	35	>3	3.7	VRC2200037090•
FRC120-90L	415	34	1.2	3.5	VRC1200035090•
FRC220-90L	460	30	>3	3.1	VRC2200031090•
	540	25	>3	2.7	VRC2200027090•
	630	22	>3	2.3	VRC2200023090•
FRC120-90L	965	15	2.9	1.5	VRC1200015090•

• = Mounting: S = Foot mount, F = Flange mount

Type	r/min	Nm	SF	Ratio	Gearbox code
2.2kW	Motor SGA100LA-4 B5 code M34002205SGA				
	1430r/min	4.5 Amps			
FRC360-100L	9.5	2080	1.2	147	VRC360147100•
	10.5	1880	1.3	133	VRC360133100•
	12.0	1650	1.5	119	VRC360119100•
	13.5	1465	1.7	103	VRC360103100•
	16	1235	2.0	87	VRC360087100•
FRC350-100L	19	1040	1.2	73	VRC350073100•
	23	860	1.5	61	VRC350061100•
FRC250-100L	27	750	1.7	52	VRC250052112•
	31	650	1.9	46	VRC250046112•
FRC240-100L	37	545	1.1	38	VRC240038100•
	42	480	1.2	34	VRC240034100•
	47	430	1.4	30	VRC240030100•
	57	355	1.7	25	VRC240025100•
	69	295	2.0	20	VRC240020112•
	82	245	2.4	18	VRC240018112•
FRC230-100L	90	225	1.3	16	VRC230016100•
	101	200	1.5	14	VRC230014100•
	113	180	1.7	13	VRC230013100•
	138	150	2.0	10	VRC230010100•
	166	125	2.5	8.7	VRC2300087100•
FRC140-100L	175	120	1.9	8.3	VRC1400083112•
FRC230-100L	196	105	2.9	7.3	VRC2300073100•
	210	95	>3	6.8	VRC2300068100•
	230	90	>3	6.3	VRC2300063100•
	240	85	>3	6.0	VRC2300060100•
	268	75	>3	5.4	VRC2300054112•
	324	65	>3	4.5	VRC2300045112•
	388	55	>3	3.7	VRC2300037112•
FRC130-100L	415	50	1.7	3.5	VRC1300035100•
FRC230-100L	460	45	>3	3.1	VRC2300031112•
	540	40	>3	2.7	VRC2300027112•
	630	35	>3	2.3	VRC2300023112•
FRC130-100L	965	25	>3	1.5	VRC1300015112•

Type	r/min	Nm	SF	Ratio	Gearbox code
3kW Motor SGA100LB-4 B5 code M34003005SGA 1430r/min 6.3 Amps					
FRC360-100L	12.0	2250	1.1	119	VRC360119100•
	13.5	2000	1.3	103	VRC360103100•
	16	1685	1.5	87	VRC360087100•
FRC350-100L	19	1415	0.9	73	VRC350073100•
	23	1170	1.1	61	VRC350061100•
FRC250-100L	27	1020	1.2	52	VRC250052112•
	31	890	1.4	46	VRC250046112•
	37	745	1.7	38	VRC250038112•
	42	655	1.9	34	VRC250034112•
FRC240-100L	47	590	1.0	30	VRC240030100•
	57	485	1.2	25	VRC240025100•
	69	400	1.5	20	VRS240020112•
	82	335	1.8	18	VRC240018112•
	90	305	2.0	16	VRC240016112•
	101	275	2.2	14	VRC240014112•
	113	245	2.5	13	VRC240013112•
	138	200	3.0	10	VRC240010112•
FRC230-100L	166	165	1.8	8.7	VRC2300087100•
FRC140-100L	175	160	1.4	8.3	VRC1400083112•
FRC230-100L	196	140	2.1	7.3	VRC2300073100•
	210	130	2.3	6.8	VRC2300068100•
	230	120	2.5	6.3	VRC2300063100•
	240	115	2.6	6.0	VRC2300060100•
	268	105	2.9	5.4	VRC2300054112•
	324	85	>3	4.5	VRC2300045112•
	388	70	>3	3.7	VRC2300037112•
FRC130-100L	415	70	1.2	3.5	VRC1300035100•
FRC230-100L	460	60	>3	3.1	VRC2300031112•
	540	50	>3	2.7	VRC2300027112•
	630	45	>3	2.3	VRC2300023112•
FRC130-100L	965	30	2.9	1.5	VRC1300015112•

Type	r/min	Nm	SF	Ratio	Gearbox code
4kW Motor SGA112M-4 B5 code M34004005SGA 1440r/min 7.9 Amps					
FRC360-112M	19	1890	1.3	73	VRC360073112•
	23	1560	1.6	61	VRC360061112•
FRC250-112M	27	1350	0.9	52	VRC250052112•
	31	1185	1.1	46	VRC250046112•
	37	990	1.3	38	VRC250038112•
	42	875	1.4	34	VRC250034112•
	47	780	1.6	30	VRC250030112•
	57	645	1.9	25	VRC250025112•
FRC240-112M	69	530	1.1	20	VRC240020112•
	82	450	1.4	18	VRC240018112•
	90	410	1.5	16	VRC240016112•
	101	365	1.7	14	VRC240014112•
	113	325	1.8	13	VRC240013112•
	138	265	2.3	10	VRC240010112•
	166	220	2.7	8.7	VRC2400087112•
FRC140-112M	175	215	1.1	8.3	VRC1400083112•
FRC240-112M	196	190	>3	7.3	VRC2400073112•
	210	175	>3	6.8	VRC2400068112•
	230	160	>3	6.3	VRC2400063112•
	240	155	>3	6.0	VRC2400060112•

• = Mounting: S = Foot mount, F = Flange mount

Type	r/min	Nm	SF	Ratio	Gearbox code
4kW Motor SGA112M-4 B5 code M34004005SGA 1440r/min 7.9 Amps					
FRC230-112M	268	135	2.2	5.4	VRC2300054112•
	324	115	2.6	4.5	VRC2300045112•
	388	95	>3	3.7	VRC2300037112•
FRC140-112M	415	90	2.5	3.5	VRC1400035112•
FRC230-112M	460	80	>3	3.1	VRC2300031112•
	540	70	>3	2.7	VRC2300027112•
	630	60	>3	2.3	VRC2300023112•
FRC130-112M	965	40	2.1	1.5	VRC1300015112•

Type	r/min	Nm	SF	Ratio	Gearbox code
5.5kW Motor SGA132S-4 B5 code M34005505SGA 1450 r/min 10.5 Amps					
FRC360-132S	19	2500	1.0	73	VRC360073132•
	23	2145	1.2	61	VRC360061132•
FRC260-132S	27	1870	1.3	52	VRC260052132•
	31	1630	1.5	46	VRC260046132•
	37	1365	1.8	38	VRC260038132•
	42	1200	2.1	34	VRC260034132•
FRC250-132S	47	1075	1.2	30	VRC250030132•
	57	885	1.4	25	VRC250025132•
	69	730	1.7	20	VRC250020132•
	82	615	2.0	18	VRC250018132•
	90	560	2.2	16	VRC250016132•
	101	500	2.5	14	VRC250014132•
	113	450	2.8	13	VRC250013132•
	138	365	>3	10	VRC250010132•
FRC240-132S	166	305	1.9	8.7	VRC2400087132•
FRC150-132S	175	295	1.4	8.3	VRC1500083132•
FRC240-132S	196	260	2.3	7.3	VRC2400073132•
	210	240	2.5	6.8	VRC2400068132•
	230	220	2.7	6.3	VRC2400063132•
	240	210	2.8	6.0	VRC2400060132•
	268	190	>3	5.4	VRC2400054132•
	324	155	>3	4.5	VRC2400045132•
	388	130	>3	3.7	VRC2400037132•
FRC150-132S	415	125	>3	3.5	VRC1500035132•
FRC240-132S	460	110	>3	3.1	VRC2400031132•
	540	95	>3	2.7	VRC2400027132•
	630	80	>3	2.3	VRC2400023132•
FRC140-132S	965	55	>3	1.5	VRC1400015132•

Type	r/min	Nm	SF	Ratio	Gearbox code
7.5kW Motor SGA132M-4 B5 code M34007505SGA 1450 r/min 13.9 Amps					
FRC260-132M	27	2500	1.0	52	VRC260052132•
	31	2220	1.1	46	VRC260046132•
	37	1860	1.3	38	VRC260038132•
	42	1640	1.5	34	VRC260034132•
	47	1465	1.7	30	VRC260030132•
	57	1210	2.1	25	VRC260025132•
FRC250-132M	69	1000	1.3	20	VRC250020132•
	82	840	1.5	18	VRC250018132•
	90	765	1.6	16	VRC250016132•
	101	680	1.8	14	VRC250014132•
	113	610	2.1	13	VRC250013132•
	138	500	2.5	10	VRC250010132•
	166	415	3.0	8.7	VRC2500087132•

Type	r/min	Nm	SF	Ratio	Gearbox code
7.5kW Motor SGA132M-4 B5 code M34007505SGA 1450 r/min 13.9 Amps					
FRC150-132M	175	400	1.0	8.3	VRC1500083132•
FRC250-132M	196	350	>3	7.3	VRC2500073132•
	210	330	>3	6.8	VRC2500068132•
	230	300	>3	6.3	VRC2500063132•
	240	290	>3	6.0	VRC2500060132•
FRC240-132M	268	260	2.3	5.4	VRC2400054132•
	324	215	2.8	4.5	VRC2400045132•
	388	180	>3	3.7	VRC2400037132•
FRC150-132M	415	170	2.4	3.5	VRC1500035132•
FRC240-132M	460	150	>3	3.1	VRC2400031132•
	540	130	>3	2.7	VRC2400027132•
	630	110	>3	2.3	VRC2400023132•
FRC140-132M	965	75	>3	1.5	VRC1400015132•

Type	r/min	Nm	SF	Ratio	Gearbox code
11kW Motor SGA160M-4 B5 code M34011005SGA 1465 r/min 21 Amps					
FRC260-160M	47	2150	1.2	30	VRC260030160•
	57	1770	1.4	25	VRC260025160•
	69	1460	1.7	20	VRC260020160•
	82	1230	2.0	18	VRC260018160•
	90	1120	2.2	16	VRC260016160•
	101	1000	2.3	14	VRC260014160•
	113	895	2.8	13	VRC260013160•
	138	730	3.0	10	VRC260010160•
	FRC250-160M	166	610	2.0	8.7
FRC160-160M	175	580	1.4	8.3	VRC1600083160•
FRC250-160M	196	515	2.4	7.3	VRC2500073160•
	210	480	2.6	6.8	VRC2500068160•
	230	440	2.8	6.3	VRC2500063160•
	240	420	3.0	6.0	VRC2500060160•
	268	380	>3	5.4	VRC2500054160•
	324	310	>3	4.5	VRC2500045160•
	388	260	>3	3.7	VRC2500037160•
	FRC150-160M	415	250	1.6	3.5
FRC250-160M	460	220	>3	3.1	VRC2500031160•
	540	190	>3	2.7	VRC2500027160•
	630	160	>3	2.3	VRC2500023160•
FRC150-160M	965	110	>3	1.5	VRC1500015160•

• = Mounting: S = Foot mount, F = Flange mount

Type	r/min	Nm	SF	Ratio	Gearbox code	
15kW Motor SGA160L-4 B5 code M34015005SGA 1460M 27 Amps						
FRC260-160L	69	2000	1.3	20	VRC260020160•	
	82	1680	1.5	18	VRC260018160•	
	90	1530	1.6	16	VRC260016160•	
	101	1360	1.8	14	VRC260014160•	
	113	1220	2.1	13	VRC260013160•	
	138	1000	2.5	10	VRC260010160•	
	166	830	3.0	8.7	VRC2600087160•	
	FRC160-160L	175	800	1.0	8.3	VRC1600083160•
	FRC260-160L	196	700	>3	7.3	VRC2600073160•
210		660	>3	6.8	VRC2600068160•	
230		600	>3	6.3	VRC2600063160•	
240		575	>3	6.0	VRC2600060160•	
FRC250-160L	268	515	>3	5.4	VRC2500054160•	
	324	425	>3	4.5	VRC2500045160•	
	388	355	>3	3.7	VRC2500037160•	
FRC160-160L	415	340	2.5	3.5	VRC1600035160•	
FRC250-160L	460	300	>3	3.1	VRC2500031160•	
	540	255	>3	2.7	VRC2500027160•	
	630	220	>3	2.3	VRC2500023160•	
FRC150-160L	965	145	>3	1.5	VRC1500015160•	

Type	r/min	Nm	SF	Ratio	Gearbox code
18.5kW Motor SGA180M-4 B5 code M34018505SGA 1470r/min 32 Amps					
FRC260-180M	166	1000	2.5	8.7	VRC2600087180•
	196	850	2.9	7.3	VRC2600073180•
	210	790	>3	6.8	VRC2600068180•
	230	725	>3	6.3	VRC2600063180•
	240	695	>3	6.0	VRC2600060180•
	268	620	>3	5.4	VRC2600054180•
	324	515	>3	4.5	VRC2600045180•
	388	430	>3	3.7	VRC2600037180•
FRC160-180M	415	420	2.0	3.5	VRC1600035180•
FRC260-180M	460	360	>3	3.1	VRC2600031180•
	540	310	>3	2.7	VRC2600027180•
	630	265	>3	2.3	VRC2600023180•
FRC160-180M	965	180	>3	1.5	VRC1600015180•

Type	r/min	Nm	SF	Ratio	Gearbox code
22kW Motor SGA180L-4 B5 code M34022005SGA 1475 r/min 38 Amps					
FRC260-180L	268	755	>3	5.4	VRC2600054180•
	324	625	>3	4.5	VRC2600045180•
	388	520	>3	3.7	VRC2600037180•
	460	440	>3	3.1	VRC2600031180•
	540	375	>3	2.7	VRC2600027180•
	630	320	>3	2.3	VRC2600023180•
FRC160-180L	965	215	>3	1.5	VRC1600015180•

Mounting arrangements

Foot mount

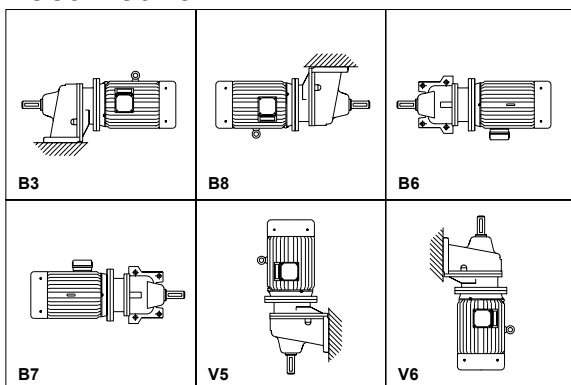

Flange mount

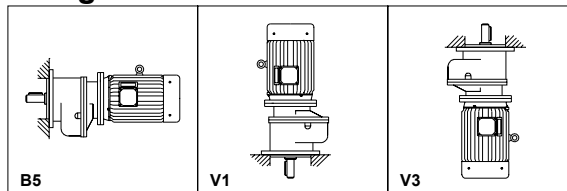

Terminal box

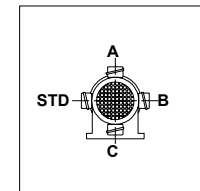

Dimensional drawings

Single stage

Foot mount

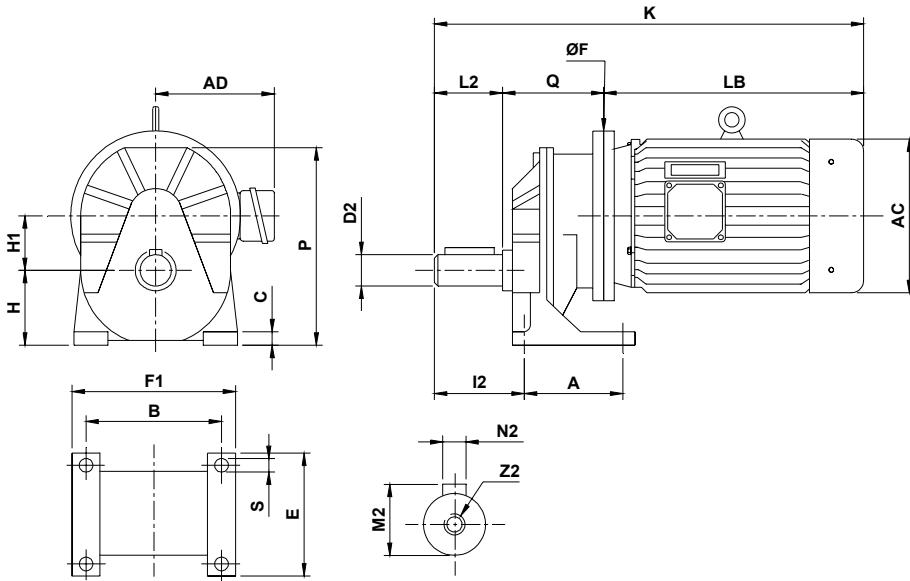

Type	Gearbox Dimensions																Motor Dimensions					Dry weight [kg]
	A	B	C	D2	E	F1	H	H1	I2	L2	M2	N2	P	Q	S	Z2	AC	AD	ØF	K	LB	
FRC 160 -160M	210	310	35	50	260	400	200	150	140	110	54	14	503	223	18.5	M14	325	255	350	823	490	228
-160L														223			325	255	350	868	535	243
-180M														223			360	285	350	893	560	278
-180L														223			360	285	350	933	600	298
FRC 150 -132S	170	250	30	42	205	310	155	120	122	100	45.5	12	398	180	16.5	M12	275	210	300	675	395	122
-132M														180			275	210	300	715	435	134
-160M														220			325	255	350	810	490	180
-160L														220			325	255	350	855	535	195
FRC 140 -100L	140	205	20	32	170	250	115	90	100	80	35.5	10	299	141	12.5	M10	205	180	250	541	320	66
-112M														141			230	190	250	561	340	72
-132S														153			275	210	300	628	395	99
-132M														153			275	210	300	668	435	111
FRC 130 -90S	115	170	14	28	140	200	95	75	76	60	31	8	248	118	10.5	M8	175	155	200	438	260	43
-90L														118			175	155	200	463	285	46
-100L														119			205	180	250	499	320	57
-112M														119			230	190	250	519	340	63
FRC 120 -80	95	150	12	24	115	180	75	60	62	50	27	8	199	99	8.5	M8	165	150	200	394	245	30
-90S														99			175	155	200	409	260	35
-90L														99			175	155	200	434	285	38
FRC 110 -80	80	110	11	19	100	130	60	45	53	40	21.5	6	155	83	8.5	M6	165	150	200	368	245	26

Flange mount

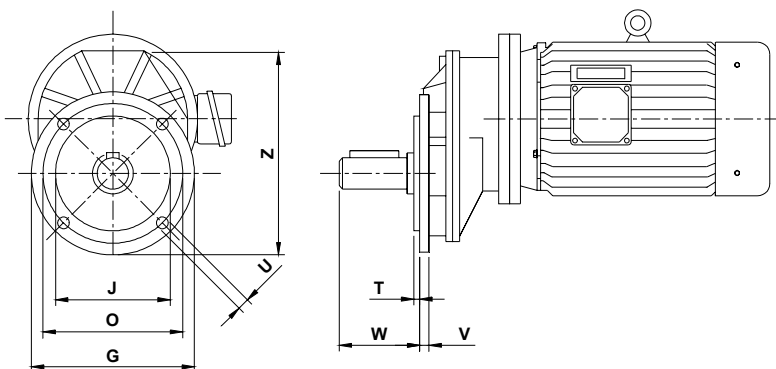

Type	Flange mount dimensions							
	G	J	O	T	U	W	V	Z
FRC 160	450	350	400	3.0	M18	118	24	529
FRC 150	350	250	300	3.0	M16	108	18	418
FRC 140	300	230	265	2.5	M12	87.5	14	334
FRC 130	250	180	215	2.5	M10	66.5	11	278
FRC 120	200	130	165	2.5	M8	54.5	10	224
FRC 110	160	110	130	2.5	M8	45.5	9	175

Note: All other dimensions as per Foot mount.

Two stage

Foot mount

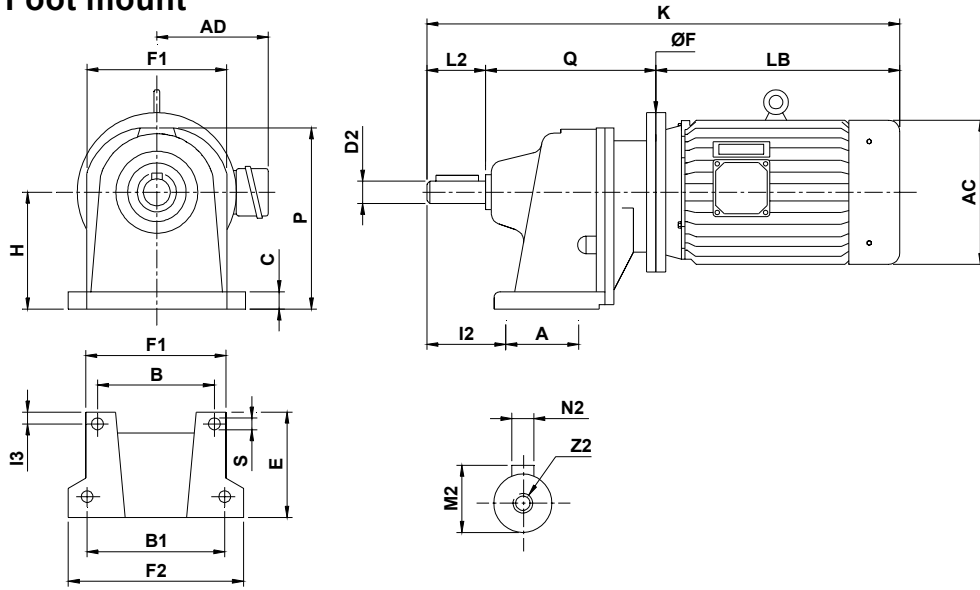

Type	Gearbox dimensions														Motor dimensions					Dry weight [kg]				
	A	B	B1	C	D2	E	F1	F2	H	I2	I3	L2	M2	N2	P	Q	S	Z2	AC		AD	ØF	K	LB
FRC 260 -132S	185	310	352	29	65	260	360	400	305	164	23	140	70	18	468	376	19	M14	275	210	300	911	395	204
-132M																376			275	210	300	951	435	216
-160M																414			325	255	350	1044	490	262
-160L																414			325	255	350	1089	535	277
-180M																414			360	285	350	1114	560	312
-180L																414			360	285	350	1154	600	332
FRC 250 -100L	140	250	283	28	50	196	290	330	245	136	20	110	54	14	375	287	17	M14	205	180	250	717	320	106
-112M																287			230	190	250	737	340	112
-132S																317			275	210	300	822	395	139
-132M																317			275	210	300	862	435	151
-160M																357			325	255	350	957	490	197
-160L																357			325	255	350	1002	535	212
FRC 240 -90S	105	190	223	20	40	154	220	260	185	111	15	90	43.5	12	285	238	15	M12	175	155	200	588	260	55
-90L																238			175	155	200	613	285	58
-100L																248			205	190	250	658	320	69
-112M																248			230	190	250	678	340	75
-132S																260			275	210	300	745	395	102
-132M																260			275	210	300	785	435	114
FRC 230 -80	85	160	187	17	32	128	190	215	155	99	14	80	35	10	240	207	13	M10	165	150	200	532	245	39
-90S																207			175	155	200	547	260	44
-90L																207			175	155	200	572	285	47
-100L																208			205	180	250	608	320	58
-112M																208			230	190	250	628	340	64
FRC 220 -80	65	140	157	14	25	105	170	185	126	67	13	50	28	8	195	175	11	M8	165	150	200	470	245	31
-90S																175			175	155	200	485	260	36
-90L																175			175	155	200	510	285	39
FRC 210 -80	58	110	125	9	20	90	130	146	96	54	10	40	22.5	6	150	154	9	M6	165	150	200	439	245	26

Flange mount

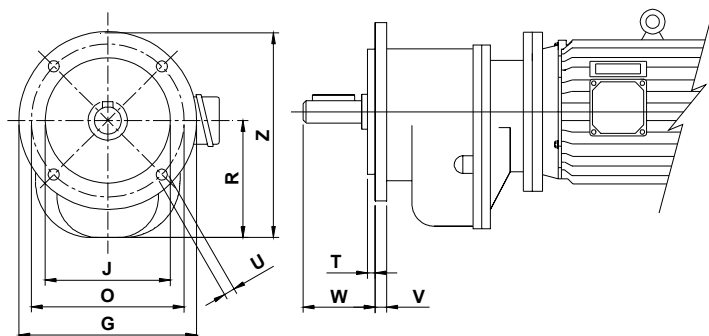

Type	Flange mount dimensions								
	G	J	O	R	T	U	W	V	Z
FRC 260	450	350	400	304	3	22	147.0	25.0	529
FRC 250	350	250	300	243	2.5	18.5	118.5	20.0	418
FRC 240	300	230	265	184	2.5	14.5	98.5	15.5	334
FRC 230	250	180	215	153	2.5	14.5	87.5	12.5	278
FRC 220	200	130	165	124	2.5	12.5	53.0	12.0	224
FRC 210	160	110	130	95	2.5	10.5	46.5	10.0	175

Note: All other dimensions as per Foot mount.

Three stage

Foot mount

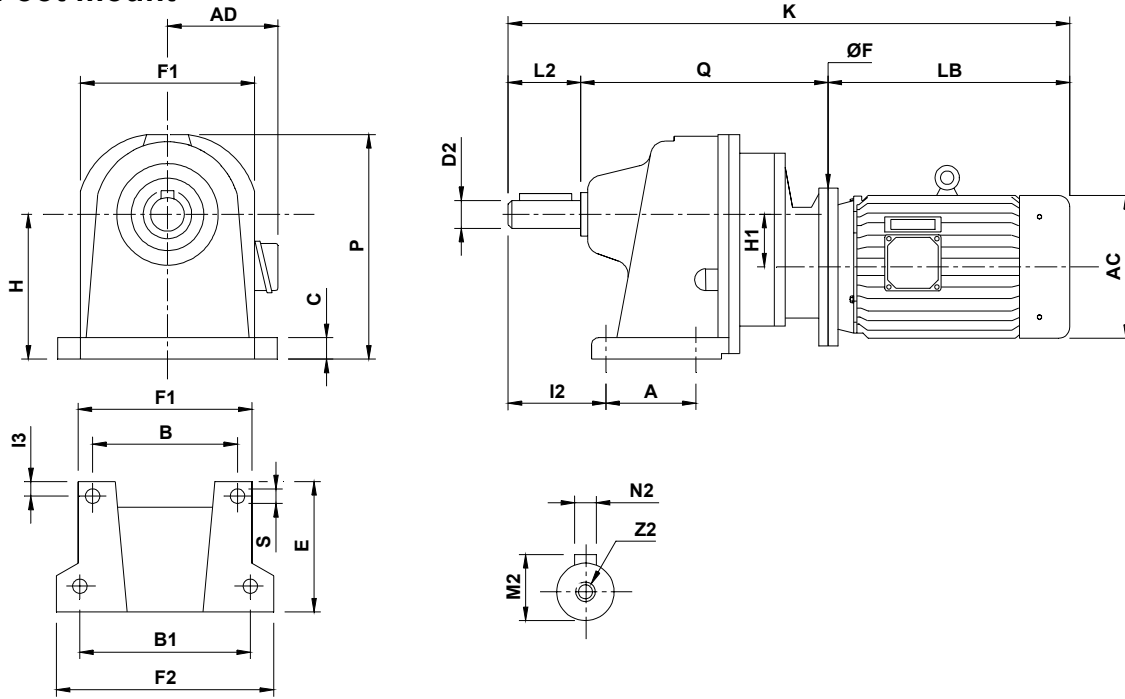

Type	Gearbox dimensions																	Motor dimensions					Dry weight [kg]		
	A	B	B1	C	D2	E	F1	F2	H	H1	I2	I3	L2	M2	N2	P	Q	S	Z2	AC	AD	ØF		K	LB
FRC 360 -80	185	310	352	29	65	260	360	400	305	121	164	23	140	70	18	468	394	19	M14	165	150	200	779	245	166
-90S																	394			175	155	200	794	260	171
-90L																	394			175	155	200	819	285	174
-100L																	404			205	180	250	864	320	185
-112M																	404			230	190	250	884	340	191
-132S																	434			275	210	300	969	395	218
FRC 350 -80	140	250	283	28	50	196	290	330	245	90	136	20	110	54	14	375	324	17	M14	165	150	200	679	245	79
-90S																	324			175	155	200	694	260	84
-90L																	324			175	155	200	719	285	87
-100L																	324			205	180	250	754	320	98
FRC 340 -80	105	190	223	20	40	154	220	260	185	75	111	15	90	43.5	12	285	271	15	M12	165	150	200	606	245	56
-90S																	271			175	155	200	621	260	61
FRC 330 -80	85	160	187	17	32	128	190	215	155	60	99	14	80	35.5	10	240	231	13	M10	165	150	200	556	245	41

Flange mount

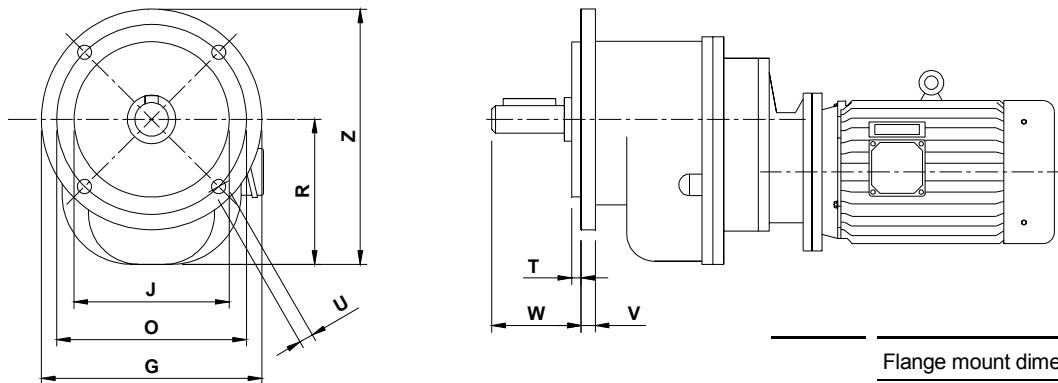

Type	Flange mount dimensions								
	G	J	O	R	T	U	W	V	Z
FRC 360	450	350	400	304	3	22	147.0	25.0	529
FRC 350	350	250	300	243	2.5	18.5	118.5	20.0	418
FRC 340	300	230	265	184	2.5	14.5	98.5	15.5	334
FRC 330	250	180	215	153	2.5	14.5	87.5	12.5	278

Note: All other dimensions as per Foot mount.

Quality. Integrity. Dependability. Performance.
It's been that way for 50 years with CMG.
Today these uncompromising standards
are still at the core of our ever expanding
range of operations. CMG's world's best
practices and technologies, plus our national



sales, spare parts and service back-up mean
we can offer a total commitment to
every customer. As depicted in our
corporate identity when you think
Motors, Transmission, Drives or research
and development Technology...think CMG.

www.cmgroup.com.au
☎ 1300 888 853

Head Office:

CMG Pty Ltd ABN 15 248 126 938
19 Corporate Avenue, Rowville VIC 3178
P.O. Box 2340 Rowville VIC 3178
Ph: (03) 9237 4000 Fax: (03) 9237 4010

State Sales Offices:

VICTORIAN SALES OFFICE

19 Corporate Avenue, Rowville VIC 3178
Ph: (03) 9237 4040 Fax: (03) 9237 4050
Sales.VIC@cmgroup.com.au

NEW SOUTH WALES SALES OFFICE

8/26 Powers Road, Seven Hills NSW 2147
Ph: (02) 9674 1555 Fax: (02) 9674 4652
Sales.NSW@cmgroup.com.au

SOUTH AUSTRALIAN SALES OFFICE

2/24 Richard Street, Hindmarsh SA 5007
Ph: (08) 8340 8333 Fax: (08) 8340 8800
Sales.SA@cmgroup.com.au

WESTERN AUSTRALIAN SALES OFFICE

8 McDermott Street, Welshpool WA 6106
Ph: (08) 9451 6111 Fax: (08) 9351 8598
Sales.WA@cmgroup.com.au

QUEENSLAND SALES OFFICE

2/6 Overlord Place, Acacia Ridge QLD 4110
Ph: (07) 3273 5366 Fax: (07) 3273 5877
Sales.QLD@cmgroup.com.au

NORTH QUEENSLAND SALES OFFICE

Cnr. John Vella Drive & Connors Road,
Paget, Mackay NQLD 4740
Ph: (07) 4952 6244 Fax: (07) 4952 6277
Sales.NQLD@cmgroup.com.au

TASMANIAN SALES OFFICE

112 Tarleton Street, East Devonport TAS 7310
Ph: (03) 6427 9911 Fax: (03) 6427 9922
Sales.TAS@cmgroup.com.au

NEW ZEALAND SALES OFFICE

CMG Electric Motors (NZ) Ltd.
2 Ross Reid Place, East Tamaki, Auckland
P.O. Box 58-864 Greenmount
Ph: (09) 273 9162 Fax: (09) 273 9062
Sales.NZ@cmgroup.com.nz



CMG Products are sold and recommended by:

ACP&D Limited

Units 6 & 9A,
Charlestown Industrial Estate,
Robinson Street,
Ashton-under-Lyne,
Lancashire, OL6 8NS.

Tel: +44 (0)161 343 1884
Fax: +44 (0)161 339 0650
e-mail: sales@acpd.co.uk
Websites: www.acpd.com &
www.acpd.co.uk

