



PowerFlex 700 Adjustable Frequency AC Drive

When reading this document, look for this symbol “ **Step x** ” to guide you through the **6 BASIC STEPS needed to install, start-up and program the PowerFlex 700. The information provided Does Not replace the User Manual and is intended for qualified drive service personnel only.** For detailed PowerFlex 700 information including application considerations and related precautions refer to the following:

Title	Publication	Available . . .
PowerFlex 700 User Manual	20B-UM001x	on the CD supplied with the drive
PowerFlex Reference Manual	PFLEX-RM001x	or at www.ab.com/manuals/dr

Step 1 Read the General Precautions



ATTENTION: This drive contains ESD (Electrostatic Discharge) sensitive parts and assemblies. Static control precautions are required when installing, testing, servicing or repairing this assembly. Component damage may result if ESD control procedures are not followed. If you are not familiar with static control procedures, reference A-B publication 8000-4.5.2, “Guarding Against Electrostatic Damage” or any other applicable ESD protection handbook.



ATTENTION: An incorrectly applied or installed drive can result in component damage or a reduction in product life. Wiring or application errors, such as, undersizing the motor, incorrect or inadequate AC supply, or excessive ambient temperatures may result in malfunction of the system.



ATTENTION: Only qualified personnel familiar with adjustable frequency AC drives and associated machinery should plan or implement the installation, start-up and subsequent maintenance of the system. Failure to comply may result in personal injury and/or equipment damage.



ATTENTION: To avoid an electric shock hazard, verify that the voltage on the bus capacitors has discharged before performing any work on the drive. Measure the DC bus voltage at the +DC & –DC terminals of the Power Terminal Block (refer to the User Manual for location). The voltage must be zero.



ATTENTION: Risk of injury or equipment damage exists. DPI or SCANport host products must not be directly connected together via 1202 cables. Unpredictable behavior can result if two or more devices are connected in this manner.



ATTENTION: The “adjust freq” portion of the bus regulator function is extremely useful for preventing nuisance overvoltage faults resulting from aggressive decelerations, overhauling loads, and eccentric loads. It forces the output frequency to be greater than commanded frequency while the drive's bus voltage is increasing towards levels that would otherwise cause a fault. However, it can also cause either of the following two conditions to occur.

1. Fast positive changes in input voltage (more than a 10% increase within 6 minutes) can cause uncommanded positive speed changes. However an “OverSpeed Limit” fault will occur if the speed reaches [Max Speed] + [Overspeed Limit]. If this condition is unacceptable, action should be taken to 1) limit supply voltages within the specification of the drive and, 2) limit fast positive input voltage changes to less than 10%. Without taking such actions, if this operation is unacceptable, the “adjust freq” portion of the bus regulator function must be disabled (see parameters 161 and 162).
2. Actual deceleration times can be longer than commanded deceleration times. However, a “Decel Inhibit” fault is generated if the drive stops decelerating altogether. If this condition is unacceptable, the “adjust freq” portion of the bus regulator must be disabled (see parameters 161 and 162). In addition, installing a properly sized dynamic brake resistor will provide equal or better performance in most cases.

Important: These faults are not instantaneous. Test results have shown that they can take between 2-12 seconds.



ATTENTION: A contactor or other device that routinely disconnects and reapplies the AC line to the drive to start and stop the motor can cause drive hardware damage. The drive is designed to use control input signals that will start and stop the motor. If an input device is used, operation must not exceed one cycle per minute or drive damage will occur.



ATTENTION: The drive start/stop/enable control circuitry includes solid state components. If hazards due to accidental contact with moving machinery or unintentional flow of liquid, gas or solids exist, an additional hardwired stop circuit may be required to remove the AC line to the drive. An auxiliary braking method may be required.



ATTENTION: If using Output Contactors, refer to the “Output Contactor Precaution” statement on page 1-12 of the *PowerFlex 700 User Manual*.

EMC Instructions

CE Conformity

Conformity with the Low Voltage (LV) Directive and Electromagnetic Compatibility (EMC) Directive has been demonstrated using harmonized European Norm (EN) standards published in the Official Journal of the European Communities. PowerFlex Drives comply with the EN standards listed below when installed according to the User and Reference Manual.

CE Declarations of Conformity are available online at:
<http://www.ab.com/certification/ce/docs>.

Low Voltage Directive (73/23/EEC)

- EN50178 Electronic equipment for use in power installations.

EMC Directive (89/336/EEC)

- EN61800-3 Adjustable speed electrical power drive systems Part 3: EMC product standard including specific test methods.

General Notes

- If the adhesive label is removed from the top of the drive, the drive must be installed in an enclosure with side openings less than 12.5 mm (0.5 in.) and top openings less than 1.0 mm (0.04 in.) to maintain compliance with the LV Directive.
- The motor cable should be kept as short as possible in order to avoid electromagnetic emission as well as capacitive currents.
- Use of line filters in ungrounded systems is not recommended.
- PowerFlex drives may cause radio frequency interference if used in a residential or domestic environment. The user is required to take measures to prevent interference, in addition to the essential requirements for CE compliance listed below, if necessary.
- Conformity of the drive with CE EMC requirements does not guarantee an entire machine or installation complies with CE EMC requirements. Many factors can influence total machine/installation compliance.
- PowerFlex drives can generate conducted low frequency disturbances (harmonic emissions) on the AC supply system. More information regarding harmonic emissions can be found in the *PowerFlex Reference Manual*.

Essential Requirements for CE Compliance

Conditions 1-6 listed below **must be** satisfied for PowerFlex drives to meet the requirements of **EN61800-3**.

1. Standard PowerFlex 700 CE compatible Drive.
2. Review important precautions/attention statements throughout this document before installing the drive.
3. Grounding as described on page 1-4 of the *User Manual*.
4. Output power, control (I/O) and signal wiring must be braided, shielded cable with a coverage of 75% or better, metal conduit or equivalent attenuation.
5. All shielded cables should terminate with the proper shielded connector.
6. Conditions in [Table A](#).

Table A PowerFlex 700 EN61800-3 EMC Compatibility

Frame	Second Environment <i>Restrict Motor Cable to 30 m (98 ft.)</i>	First Environment Restricted Distribution
	<i>Any Drive and Option</i>	
0	✓	<i>Refer to PowerFlex Reference Manual</i>
1	✓	
2	✓	
3	✓	

Step 2 Mount the Drive – Minimum Requirements

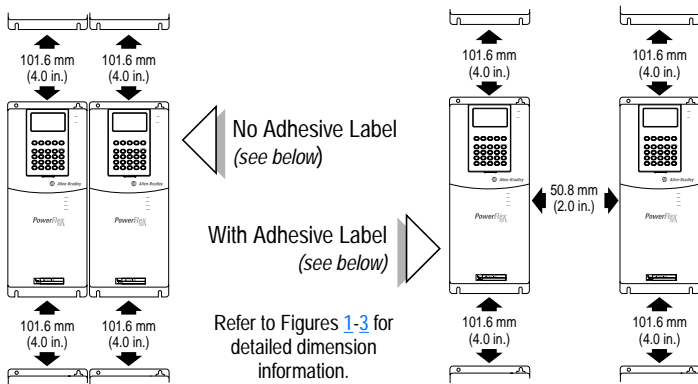

Operating Temperatures

PowerFlex 700 drives are designed to operate at 0° to 40° C ambient.

To operate in installations between 41° and 50° C, see [Table B](#).

Table B Acceptable Surrounding Air Temperature & Required Actions

Drive Catalog Number	Required Action . . .		
	IP 20, NEMA Type 1	IP 20, NEMA Type Open	IP 00, NEMA Type Open
All <i>Except</i> 20BC072	No Action Required	Remove Top Label	Remove Top Label & Vent Plate ⁽¹⁾
20BC072	40° C	45° C	50° C

- (1) To remove vent plate (see [Figure 3 on page 8](#) for location), lift top edge of plate from the chassis. Rotate the plate out from the back plate.

Important: Removing the adhesive label from the drive changes the NEMA enclosure rating from Type 1 to Open type.

Dimensions

Figure 1 PowerFlex 700 Frames 0-3 (0 Frame Shown)

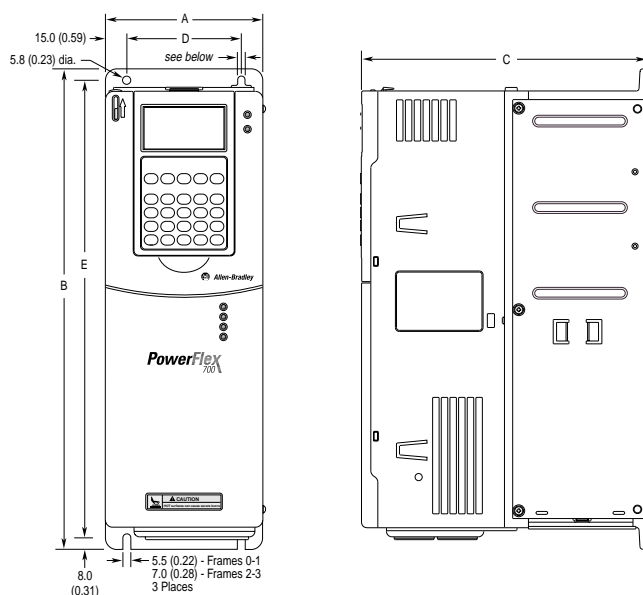

Dimensions are in millimeters and (inches).

Frame (Table C)	A	B	C	D	E	Weight ⁽¹⁾ kg (lbs.)	
						Drive	Drive & Packaging
0	110.0 (4.33)	336.0 (13.23)	200.0 (7.87)	80.0 (3.15)	320.0 (12.60)	5.22 (11.5)	8.16 (18)
1	135.0 (5.31)	336.0 (13.23)	200.0 (7.87)	105.0 (4.13)	320.0 (12.60)	7.03 (15.5)	9.98 (22)
2	222.0 (8.74)	342.5 (13.48)	200.0 (7.87)	192.0 (7.56)	320.0 (12.60)	12.52 (27.6)	15.20 (33.5)
3	222.0 (8.74)	517.5 (20.37)	200.0 (7.87)	192.0 (7.56)	500.0 (19.69)	18.55 (40.9)	22.68 (50)

- (1) Weights include HIM and Standard I/O.

Figure 2 PowerFlex 700 Frame 5

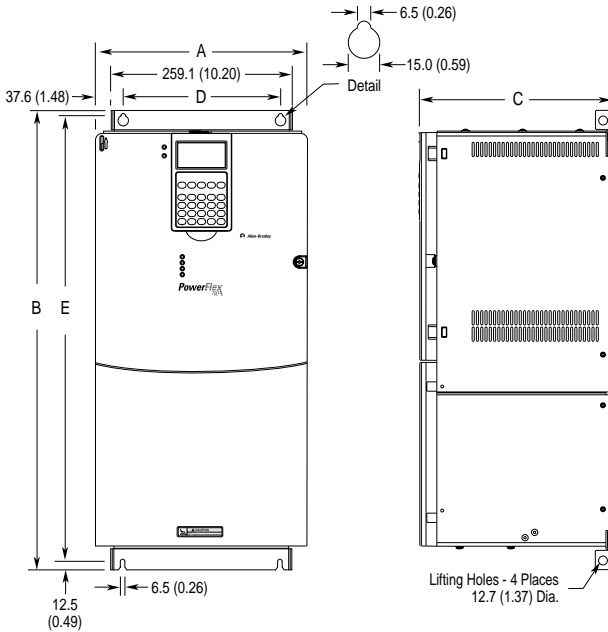

Dimensions are in millimeters and (inches).

Frame (Table C)	A (Max.)	B	C (Max.)	D	E	Approx. Weight ⁽¹⁾ kg (lbs.)	
						Drive	Drive & Packaging
5	308.9 (12.16)	644.5 (25.37) ⁽²⁾	275.4 (10.84)	225.0 (8.86)	625.0 (24.61)	37.19 (82.0)	42.18 (93.0)

(1) Weights include HIM and Standard I/O.

(2) When using the supplied junction box (100 HP drives Only), add an additional 45.1 mm (1.78 in.).

Table C PowerFlex 700 Frames

Frame	208/240V AC Input		400V AC Input		480V AC Input	
	ND HP	HD HP	ND kW	HD kW	ND HP	HD HP
0	0.5	0.33	0.37	0.25	0.5	0.33
	1	0.75	0.75	0.55	1	0.75
	2	1.5	1.5	0.75	2	1.5
	3	2	2.2	1.5	3	2
	–	–	4	2.2	5	3
	–	–	5.5	4	7.5	5
1	5	3	7.5	5.5	10	7.5
	7.5	5	11	7.5	15	10
2	10	7.5	15	11	20	15
	–	–	18.5	15	25	20
3	15	10	22	18.5	30	25
	20	15	30	22	40	30
	–	–	37	30	50	40
5	–	–	55	45	–	–
	–	–	–	–	75	60
	–	–	–	–	100	75

Figure 3 Bottom View Dimensions

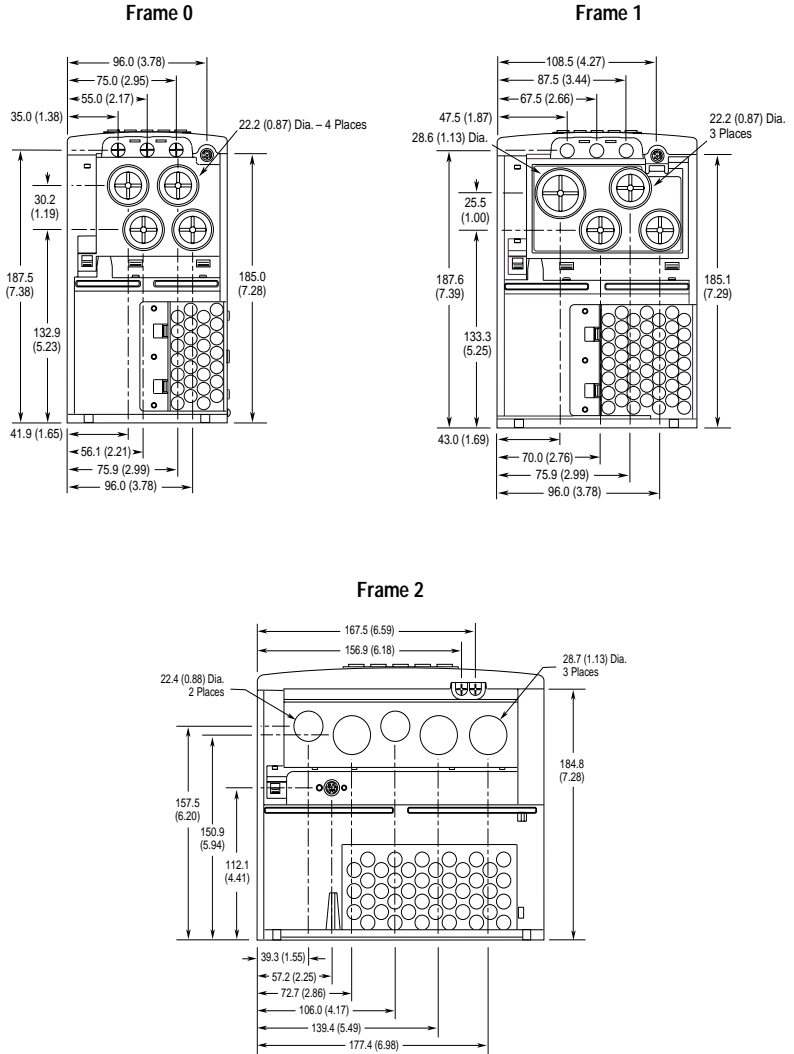

Dimensions are in millimeters and (inches).

Figure 3 PowerFlex 700 Bottom View Dimensions (continued)

Frame 3 – All Drives
except 50 HP, 480V (37 kW, 400V)

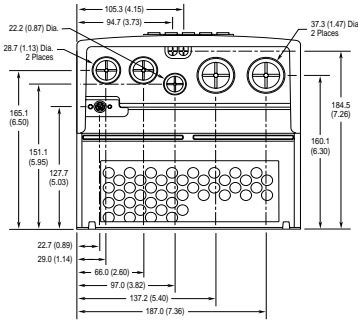

Frame 3 – 50 HP, 480V (37 kW, 400V)
Normal Duty Drive

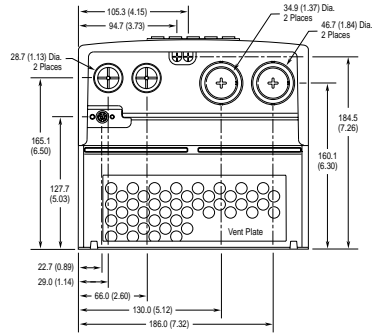

Frame 5 – 75 HP, 480V (55kW, 400V) Normal Duty Drive

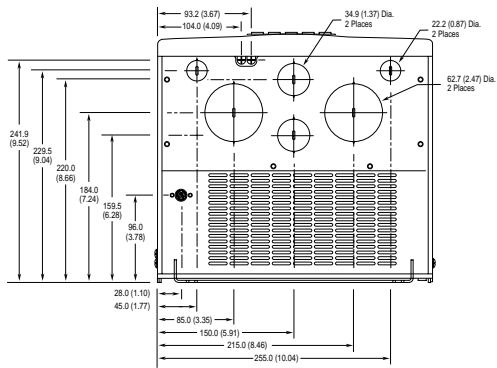

Frame 5 – 100 HP, 480V Normal Duty Drive

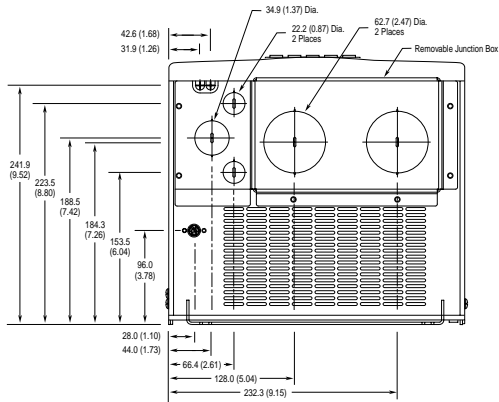

Dimensions are in millimeters
and (inches)

Step 3 Power Wiring – Wire Recommendations

A variety of cable types are acceptable for drive installations. For many installations, unshielded cable is adequate, provided it can be separated from sensitive circuits. As an approximate guide, allow a spacing of 0.3 meters (1 foot) for every 10 meters (32.8 feet) of length. In all cases, long parallel runs must be avoided. Do not use cable with an insulation thickness less than or equal to 15 mils (0.4mm/0.015 in.). See [Table D](#).

Unshielded

THHN, THWN or similar wire is acceptable for drive installation in dry environments provided adequate free air space and/or conduit fill rates limits are provided. **Do not use THHN or similarly coated wire in wet areas.** Any wire chosen must have a minimum insulation thickness of 15 Mils and should not have large variations in insulation concentricity.

Shielded/Armored Cable

Shielded cable is recommended if sensitive circuits or devices are connected or mounted to the machinery driven by the motor. See [Table D](#). For further information on acceptable and unacceptable cable types, refer to “Power Wiring” in the *PowerFlex 700 User Manual*.

Table D Recommended Shielded Cable

Type	Wire Type(s)	Description
Power Standard (Option 1)	600V, 90°C (194°F) XHHW2/RHW-2 Anixter B209500-B209507, Belden 29501-29507, or equivalent	<ul style="list-style-type: none"> • Four tinned copper conductors with XLP insulation. • Copper braid/aluminum foil combination shield and tinned copper drain wire. • PVC jacket.
Standard (Option 2)	Tray rated 600V, 90° C (194° F) RHH/RHW-2 Anixter OLF-7xxxxx or equivalent	<ul style="list-style-type: none"> • Three tinned copper conductors with XLPE insulation. • 5 mil single helical copper tape (25% overlap min.) with three bare copper grounds in contact with shield. • PVC jacket.
Class I & II; Division I & II	Tray rated 600V, 90° C (194° F) RHH/RHW-2 Anixter 7V-7xxxx-3G or equivalent	<ul style="list-style-type: none"> • Three bare copper conductors with XLPE insulation and impervious corrugated continuously welded aluminum armor. • Black sunlight resistant PVC jacket overall. • Three copper grounds on #10 AWG and smaller.

Table E Power Terminal Block Specifications

Name	Frame	Description	Wire Size Range ⁽¹⁾		Torque	
			Maximum	Minimum	Maximum	Recommended
Power Terminal Block	0 & 1	Input power and motor connections	4.0 mm ² (10 AWG)	0.5 mm ² (22 AWG)	1.7 N-m (15 lb.-in.)	0.8 N-m (7 lb.-in.)
		2	Input power and motor connections	10.0 mm ² (6 AWG)	0.8 mm ² (18 AWG)	1.7 N-m (15 lb.-in.)
	3	Input power and motor connections	25.0 mm ² (3 AWG)	2.5 mm ² (14 AWG)	3.6 N-m (32 lb.-in.)	1.8 N-m (16 lb.-in.)
		BR1, 2 terminals	10.0 mm ² (6 AWG)	0.8 mm ² (18 AWG)	1.7 N-m (15 lb.-in.)	1.4 N-m (12 lb.-in.)
	5 (75 HP)	Input power, BR1, 2, DC+, DC- and motor connections	35.0 mm ² (1/0 AWG)	2.5 mm ² (14 AWG)	3.6 N-m (32 lb.-in.)	3.6 N-m (32 lb.-in.)
		PE	35.0 mm ² (1/0 AWG)	16.0 mm ² (6 AWG)	5 N-m (44 lb.-in.)	5 N-m (44 lb.-in.)
	5 (100 HP)	Input power, DC+, DC- and motor connections	70.0 mm ² (3/0 AWG)	16.0 mm ² (4 AWG)	15 N-m (133 lb.-in.)	15 N-m (133 lb.-in.)
		BR1, 2, terminals	35.0 mm ² (1/0 AWG)	2.5 mm ² (14 AWG)	3.6 N-m (32 lb.-in.)	3.6 N-m (32 lb.-in.)
		PE	35.0 mm ² (1/0 AWG)	16.0 mm ² (6 AWG)	5 N-m (44 lb.-in.)	5 N-m (44 lb.-in.)
AUX Terminal Block	0-3	Auxiliary Control Voltage ⁽²⁾	1.3 mm ² (16 AWG)	0.2 mm ² (24 AWG)	—	—
	5		4.0 mm ² (10 AWG)	0.5 mm ² (22 AWG)	0.6 N-m (5.3 lb.-in.)	0.6 N-m (5.3 lb.-in.)

(1) Maximum/minimum sizes that the terminal block will accept - these are not recommendations.

(2) External control power:
 UL Installation - 300V DC, ±10%, Non UL Installation - 270-600V DC, ±10%.
 0-3 Frame - 40 W, 165 mA, 5 Frame - 80 W, 90 mA.

Power & Ground Wiring

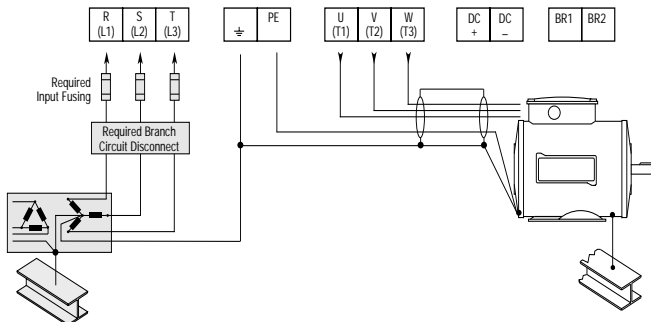

Step 4 Control Wiring

- Always use copper wire.
- Wire with an insulation rating of 600V or greater is recommended.
- Control and signal wires should be separated from power wires by at least 0.3 meters (1 foot).
- I/O terminals labeled “(-)” or “Common” are not referenced to earth ground and are designed to greatly reduce common mode interference. Grounding these terminals can cause signal noise.



ATTENTION: Configuring an analog input for 0-20mA operation and driving it from a voltage source could cause component damage. Verify proper configuration prior to applying input signals.



ATTENTION: Hazard of personal injury or equipment damage exists when using bipolar input sources. Noise and drift in sensitive input circuits can cause unpredictable changes in motor speed and direction. Use speed command parameters to help reduce input source sensitivity.

Table F Recommended Control Wire

Type	Wire Type(s)	Description	Insulation Rating
Signal	Analog I/O	Belden 8760/9460 (or equiv.)	300V, 60° C (140° F), Minimum
		Belden 8770 (or equiv.)	
	Encoder/ Pulse I/O	Less than or equal to 30 m (98 ft.) – Belden 9728 (or equiv.)	
		Greater than 30 m (98 ft.) – Belden 9773 (or equiv.)	
Digital I/O	Unshielded	Per US NEC or applicable national or local code	300V, 60° C (140° F), Minimum
	Shielded	Multi-conductor shielded cable such as Belden 8770 (or equiv.)	

- (1) If the wires are short and contained within a cabinet which has no sensitive circuits, the use of shielded wire may not be necessary, but is always recommended.

Table G I/O Terminal Blocks

Name	Frame	Description	Wire Size Range ⁽¹⁾		Torque	
			Maximum	Minimum	Maximum	Recommended
I/O Terminal Block	0-5	Signal & control connections	2.1 mm ² (14 AWG)	0.30 mm ² (22 AWG)	1.36 N-m (12 lb.-in.)	1.36 N-m (12 lb.-in.)
Encoder Terminal Block ⁽²⁾	0-5	Encoder power & signal connections	0.75 mm ² (18 AWG)	0.196 mm ² (24 AWG)	1.36 N-m (12 lb.-in.)	1.36 N-m (12 lb.-in.)
SHLD Terminal	0-5	Terminating point for wiring shields	—	—	1.6 N-m (14 lb.-in.)	1.6 N-m (14 lb.-in.)

- (1) Maximum/minimum sizes that the terminal block will accept - these are not recommendations.

- (2) Not available with Standard Control option.

I/O Terminal Blocks

Figure 4 Vector Control Option I/O Terminal Designations

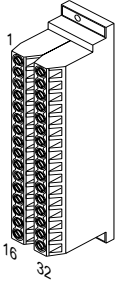

Vector Control Option	No.	Signal	Factory Default	Description	Related Param.	
	1	Analog In 1 (-) ⁽¹⁾	(2)	Isolated ⁽³⁾ , bipolar, differential, ±10V/4-20mA, 11 bit & sign, 88k ohm input impedance. For 4-20mA, a jumper must be installed at terminals 17 & 18 (or 19 & 20).	320 - 327	
	2	Analog In 1 (+) ⁽¹⁾				
	3	Analog In 2 (-) ⁽¹⁾				
	4	Analog In 2 (+) ⁽¹⁾				
	5	Pot Common	-	For (+) and (-) 10V pot references.		
	6	Analog Out 1 (-)	(2)	Bipolar (current output is not bipolar), ±10V/4-20mA, 11 bit & sign, voltage mode - limit current to 5 mA. Current mode - max. load resistance is 400 ohms.	340 - 347	
	7	Analog Out 1 (+)				
	8	Analog Out 2 (-)				
	9	Analog Out 2 (+)				
	10	Reserved for Future Use				
	11	Digital Out 1 – N.C. ⁽⁴⁾	Fault	Max. Resistive Load: 240V AC/30V DC – 1200VA, 150W Max. Current: 5A, Min. Load: 10mA	380 - 391	
	12	Digital Out 1 Common				
	13	Digital Out 1 – N.O. ⁽⁴⁾	NOT Fault			
	14	Digital Out 2 – N.C. ⁽⁴⁾	NOT Run	Max. Inductive Load: 240V AC/30V DC – 840VA, 105W Max. Current: 3.5A, Min. Load: 10mA		
	15	Digital Out 2/3 Com.				
	16	Digital Out 3 – N.O. ⁽⁴⁾	Run			
	17	Current In Jumper ⁽¹⁾ –		Placing a jumper across terminals 17 & 18 (or 19 & 20) will configure that analog input for current.		
	18	Analog In 1				
	19	Current In Jumper ⁽¹⁾ –				
	20	Analog In 2				
	21	-10V Pot Reference	-	2k ohm minimum load.		
	22	+10V Pot Reference	-			
	23	Reserved for Future Use				
	24	+24VDC ⁽⁵⁾	-	Drive supplied logic input power. ⁽⁵⁾		
	25	Digital In Common	-			
	26	24V Common ⁽⁵⁾	-	Same as terminal 24.		
	27	Digital In 1	Stop - CF	115V AC, 50/60 Hz - Opto isolated	361 - 366	
	28	Digital In 2	Start	Low State: less than 30V AC		
	29	Digital In 3	Jog	High State: greater than 100V AC		
	30	Digital In 4	Speed Sel 1	24V DC - Opto isolated		
	31	Digital In 5	Speed Sel 2	Low State: less than 5V DC		
	32	Digital In 6/Hardware Enable, see pg. 13	Speed Sel 3	High State: greater than 20V DC 11.2 mA DC		

(1) **Important:** 4-20mA operation requires a jumper at terminals 17 & 18 (or 19 & 20). Drive damage may occur if jumper is not installed.

(2) These inputs/outputs are dependant on a number of parameters (see "Related Parameters").

(3) Differential Isolation - External source must be maintained at less than 160V with respect to PE. Input provides high common mode immunity.

(4) Contacts in unpowered state. Any relay programmed as Fault or Alarm will energize (pick up) when power is applied to drive and deenergize (drop out) when a fault or alarm exists. Relays selected for other functions will energize only when that condition exists and will deenergize when condition is removed.

(5) 150mA maximum Load. Not present on 115V versions.

Encoder Terminal Block (Vector Control Option Only)

Figure 5 Encoder Terminal Designations

No.	Description (refer to User Manual for encoder specifications)	
8	+12V DC Power	Internal power source 250 mA.
7	+12V DC Return (Common)	
6	Encoder Z (NOT)	Pulse, marker or registration input.
5	Encoder Z	
4	Encoder B (NOT)	Quadrature B input.
3	Encoder B	
2	Encoder A (NOT)	Single channel or quadrature A input.
1	Encoder A	

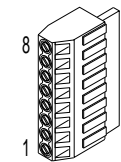

Figure 6 Sample Encoder Wiring

I/O	Connection Example	I/O	Connection Example
Encoder Power – Internal Drive Power Internal (drive) 12V DC, 250mA		Encoder Power – External Power Source	
Encoder Signal – Single-Ended, Dual Channel		Encoder Signal – Differential, Dual Channel	

Hardware Enable Circuitry (Vector Control Option Only)

By default, the user can program a digital input as an Enable input. The status of this input is *interpreted by drive software*. If the application requires the drive to be disabled *without* software interpretation, a “dedicated” hardware enable configuration can be utilized. This is done by removing a jumper and wiring the enable input to “Digital In 6” (see below).

1. Remove the I/O Control Cassette & cover as described in the *User Manual*.
2. Locate & remove Jumper J10 on the Main Control Board (see diagram).
3. Re-assemble cassette.
4. Wire Enable to “Digital In 6” (see [Figure 4](#)).
5. Verify that [Digital In6 Sel], parameter 366 is set to “1, Enable.”

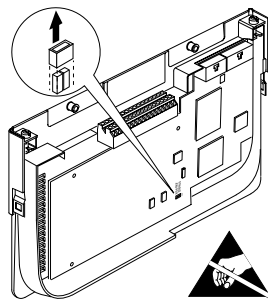
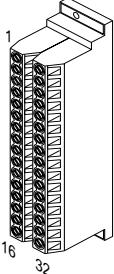

Figure 7 Standard Control Option I/O Terminal Designations

Standard Control Option	No.	Signal	Factory Default	Description	Related Param.		
	1	Anlg Volts In 1 (-)	(2)	Isolated ⁽³⁾ , bipolar, differential, ±10V, 11 bit & sign, 88k ohm input impedance.	320 - 327		
	2	Anlg Volts In 1 (+)					
	3	Anlg Volts In 2 (-)	(2)	Isolated ⁽⁴⁾ , bipolar, differential, ±10V, 11 bit & sign, 88k ohm input impedance.			
	4	Anlg Volts In 2 (+)					
	5	Pot Common	-		For (+) and (-) 10V pot references.		
	6	Anlg Volts Out 1 (-)	(2)	Bipolar, ±10V, 11 bit & sign, 2k ohm minimum load.	340 - 344		
	7	Anlg Volts Out 1 (+)					
	8	Anlg Current Out 1 (-)	(2)	4-20mA, 11 bit & sign, 400 ohm maximum load.			
	9	Anlg Current Out 1 (+)					
	10	Reserved for Future Use					
	11	Digital Out 1 - N.C. ⁽¹⁾	Fault		Max. Resistive Load: 240V AC/30V DC - 1200VA, 150W Max. Current: 5A, Min. Load: 10mA Max. Inductive Load: 240V AC/30V DC - 840VA, 105W Max. Current: 3.5A, Min. Load: 10mA	380 - 387	
	12	Digital Out 1 Common					
	13	Digital Out 1 - N.O. ⁽¹⁾	NOT Fault				
	14	Digital Out 2 - N.C. ⁽¹⁾	NOT Run				
	15	Digital Out 2 Common					
	16	Digital Out 2 - N.O. ⁽¹⁾	Run				
	17	Anlg Current In 1 (-)	(2)	Isolated ⁽³⁾ , 4-20mA, 11 bit & sign, 124 ohm input impedance.	320 - 327		
	18	Anlg Current In 1 (+)					
	19	Anlg Current In 2 (-)	(2)	Isolated ⁽⁴⁾ , 4-20mA, 11 bit & sign, 124 ohm input impedance.			
	20	Anlg Current In 2 (+)					
	21	-10V Pot Reference	-		2k ohm minimum.		
	22	+10V Pot Reference	-				
	23	Reserved for Future Use					
	24	+24VDC ⁽⁵⁾	-		Drive supplied logic input power. ⁽⁵⁾		
	25	Digital In Common	-				
	26	24V Common ⁽⁵⁾	-		Drive supplied logic input power. ⁽⁵⁾		
	27	Digital In 1	Stop - CF		115V AC, 50/60 Hz - Opto isolated	361 - 366	
	28	Digital In 2	Start		Low State: less than 30V AC High State: greater than 100V AC		
	29	Digital In 3	Jog		24V AC/DC, 50/60 Hz - Opto isolated		
	30	Digital In 4	Speed Sel 1		Low State: less than 5V AC/DC High State: greater than 20V AC/DC		
	31	Digital In 5	Speed Sel 2		11.2 mA DC		
	32	Digital In 6	Speed Sel 3				

(1) Contacts in unpowered state. Any relay programmed as Fault or Alarm will energize (pick up) when power is applied to drive and deenergize (drop out) when a fault or alarm exists. Relays selected for other functions will energize only when that condition exists and will deenergize when condition is removed.

(2) These inputs/outputs are dependant on a number of parameters. See "Related Parameters."

(3) Differential Isolation - External source must be maintained at less than 160V with respect to PE.

Input provides high common mode immunity.

(4) Differential Isolation - External source must be less than 10V with respect to PE.

(5) 150mA maximum Load. Not present on 115V versions.

I/O Wiring Examples

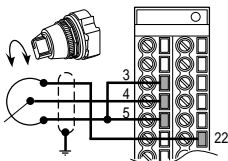
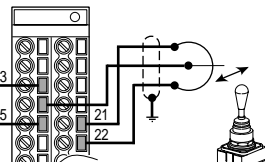
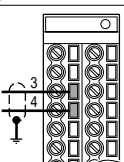
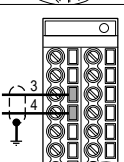
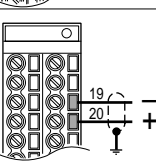
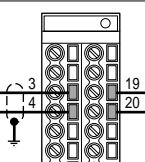
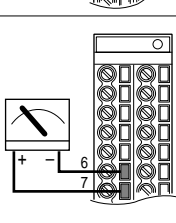
Input/Output	Connection Example	Required Parameter Changes
Potentiometer Unipolar Speed Reference ⁽¹⁾ 10k Ohm Pot. Recommended (2k Ohm Minimum)		<ul style="list-style-type: none"> Adjust Scaling: Parameters 91/92 and 325/326 View Results: Parameter 002
Joystick Bipolar Speed Reference ⁽¹⁾ ±10V Input		<ul style="list-style-type: none"> Set Direction Mode: Parameter 190 = "1, Bipolar" Adjust Scaling: Parameters 91/92 and 325/326 View Results: Parameter 002
Analog Input Bipolar Speed Reference ±10V Input		<ul style="list-style-type: none"> Set Direction Mode: Parameter 190 = "1, Bipolar" Adjust Scaling: Parameters 91/92 and 325/326 View Results: Parameter 002
Analog Voltage Input Unipolar Speed Reference 0 to +10V Input		<ul style="list-style-type: none"> Configure Input with parameter 320 Adjust Scaling: Parameters 91/92 and 325/326 View results: Parameter 002
Analog Current Input Unipolar Speed Reference Standard 4-20 mA Input		<ul style="list-style-type: none"> Configure Input for Current: Parameter 320, Bit 1 = "1, Current" Adjust Scaling: Parameters 91/92 and 325/326 View Results: Parameter 002
Analog Current Input Unipolar Speed Reference Vector 4-20 mA Input		<ul style="list-style-type: none"> Configure Input for Current: Parameter 320 and add jumper at appropriate terminals Adjust Scaling: Parameters 91/92 and 325/326 View results: Parameter 002
Analog Output ±10V, 4-20 mA Bipolar +10V Unipolar (shown) Standard Control 4-20 mA Unipolar (use term. 8 & 9)		<ul style="list-style-type: none"> Configure with Parameter 340 Select Source Value: Parameter 384, [Digital Out1 Sel] Adjust Scaling: Parameters 343/344

⁽¹⁾ Refer to the Attention statement on [page 11](#) for important bipolar wiring information.

I/O Wiring Examples (continued)

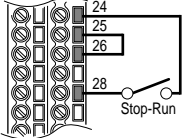
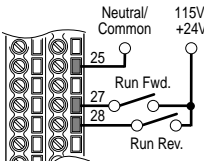
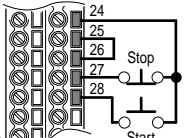
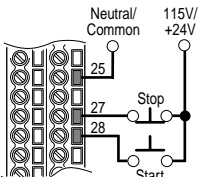
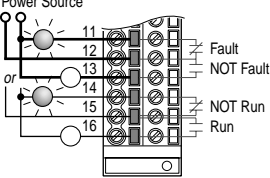
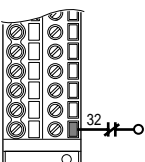
Input/Output	Connection Example	Required Parameter Changes
<p>2-Wire Control Non-Reversing⁽¹⁾ 24V DC internal supply</p>		<ul style="list-style-type: none"> • Disable Digital Input:#1: Parameter 361 = "0, Unused" • Set Digital Input #2: Parameter 362 = "7, Run" • Set Direction Mode: Parameter 190 = "0, Unipolar"
<p>2-Wire Control Reversing⁽¹⁾ External supply (I/O Board dependent)</p>		<ul style="list-style-type: none"> • Set Digital Input:#1: Parameter 361 = "8, Run Forward" • Set Digital Input #2: Parameter 362 = "9, Run Reverse"
<p>3-Wire Control Internal supply</p>		<ul style="list-style-type: none"> • No Changes Required
<p>3-Wire Control External supply (I/O Board dependent). Requires 3-wire functions only (Digital In1 Sel). Using 2-wire selections will cause a type 2 alarm.</p>		<ul style="list-style-type: none"> • No Changes Required
<p>Digital Output Relays shown in powered state with drive faulted. See pages 12 & 14. <u>Standard Control</u> 1 relay at terminals 14-16. <u>Vector Control</u> 2 relays at terminals 14-16.</p>		<ul style="list-style-type: none"> • Select Source to Activate: Parameters 380/384
<p>Enable Input</p>		<ul style="list-style-type: none"> • <u>Standard Control</u> Configure with parameter 366 • <u>Vector Control</u> Configure with parameter 366 For dedicated hardware Enable: Remove Jumper J10 (see page 13)

⁽¹⁾ **Important:** Programming inputs for 2 wire control deactivates all HIM Start buttons.

Step 5 Start-Up Check List

1. Verify supply voltage.

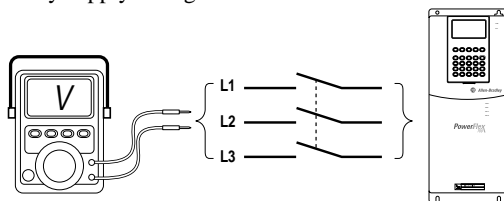

2. Check power wiring.

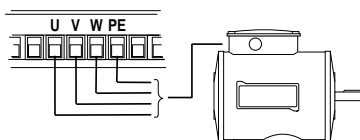

3. Check control wiring.

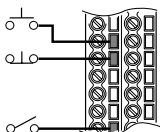

4. Apply AC power and control voltages to the drive.

If any of the six digital inputs are configured to Stop – CF (CF = Clear Fault) or Enable, verify that signals are present or the drive will not start. Refer to [Troubleshooting – Abbreviated Fault & Alarm Listing on page 26](#) for a list of potential digital input conflicts. If the STS LED is not flashing green at this point, refer to [Status Indicators on page 18](#).

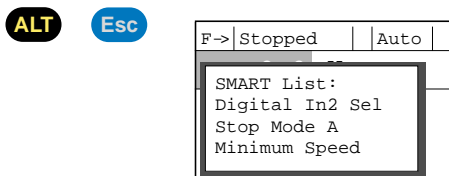

5. Select Start-Up method: SMART Start . . .

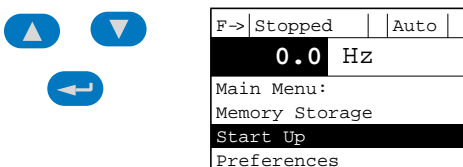

or any of the other start-up routines . . .

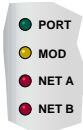

Status Indicators

Name	Color	State	Description
	Green	Steady	Illuminates when power is applied to the drive.
		Green	Flashing
		Steady	Drive running, no faults are present.
Yellow		Flashing, Drive Stopped	A type 2 alarm condition exists, the drive cannot be started. Check parameter 212 [Drive Alarm 2].
		Flashing, Drive Running	An intermittent type 1 alarm condition is occurring. Check parameter 211 [Drive Alarm 1].
		Steady, Drive Running	A continuous type 1 alarm condition exists. Check parameter 211 [Drive Alarm 1].
Red		Flashing	Fault has occurred. Check [Fault x Code] or Fault Queue.
		Steady	A non-resettable fault has occurred.
		Refer to the Communication Adapter User Manual.	
			Status of communications module (when installed).
			Status of network (if connected).
			Status of secondary network (if connected).

Step 6 Program the Drive – Parameter Files & Groups

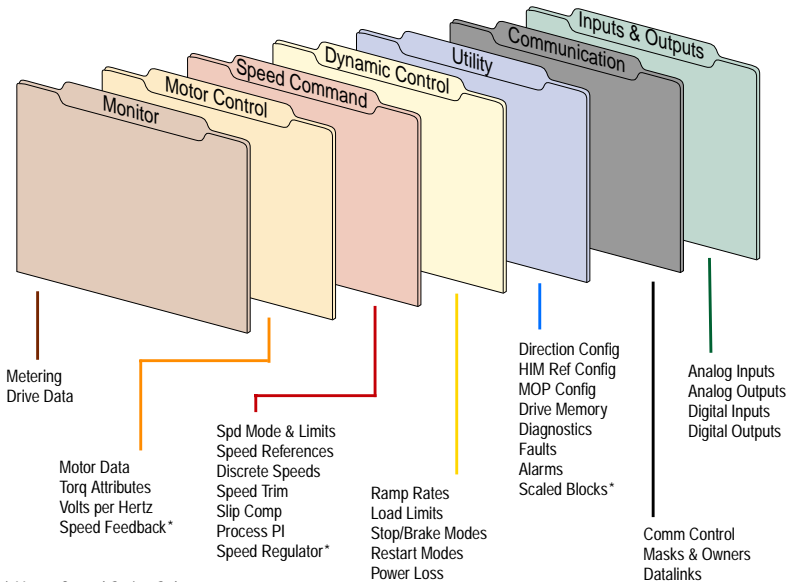

Important Notes about Parameters

 = Stop drive before changing this parameter.

 = 32 bit parameter in the Standard Control option. All parameters in the Vector Control option are 32 bit.

 = Parameter only displayed when [Motor Cntl Sel] is set to "4."

Standard = This parameter is specific to the Standard Control Option.







Vector = This parameter will only be available with the Vector Control option.

Important: Some parameters will have two unit values:

- Analog inputs can be set for current or voltage with [Anlg In Config], param. 320.
- Setting [Speed Units], parameter 79 on Vector Control drives selects Hz or RPM.
- Values that pertain to Vector Control drives only will be indicated by "**Vector**."

 indicates that additional information is available in *Appendix C* of the *User Manual*.

Frequently Used Parameters

File	Group	No.	Parameter Name & Description	Values	Related
MOTOR CONTROL	Motor Data	042	[Motor NP FLA]  Set to the motor nameplate rated full load amps.	Default: Based on Drive Rating Min/Max: 0.0/[Rated Amps] × 2 Units: 0.1 Amps	047 048
		047	[Motor OL Hertz]  Selects the output frequency below which the motor operating current is derated. The motor thermal overload will generate a fault at lower levels of current.	Default: Motor NP Hz/3 Min/Max: 0.0/Motor NP Hz Units: 0.1 Hz	042 220 
		048	[Motor OL Factor]  Sets the operating level for the motor overload. $\text{Motor FLA} \times \text{OL Factor} = \text{Operating Level}$	Default: 1.0 Min/Max: 0.20/2.0 Units: 0.01	042 220 
	Torq Attributes	053	Standard [Torque Perf Mode]  Sets the method of motor torque production.	Default: 0 "Sensrls Vect" Options: 0 "Sensrls Vect" 1 "SV Economize" 2 "Custom V/Hz" 3 "Fan/Pmp V/Hz"	
			Vector [Motor Cntl Sel] Sets the method of motor control used in the drive. Important: "Flux Vector" mode requires autotuning of the motor, both coupled and uncoupled to the load.	Default: 0 "Sensrls Vect" Options: 0 "Sensrls Vect" 1 "SV Economize" 2 "Custom V/Hz" 3 "Fan/Pmp V/Hz" 4 "Flux Vector"	

File	Group	No.	Parameter Name & Description	Values	Related
MOTOR CONTROL	Torq Attributes	061	[Autotune] Provides a manual or automatic method for setting [IR Voltage Drop], [Flux Current Ref] and [Ixo Voltage Drop]. Valid only when parameter 53 is set to "Sensrls Vect," "SV Economize" or "Flux Vector."	Default: 3 "Calculate" Options: 0 "Ready" 1 "Static Tune" 2 "Rotate Tune" 3 "Calculate"	053 062
			"Ready" (0) = Parameter returns to this setting following a "Static Tune" or "Rotate Tune." It also permits manually setting [IR Voltage Drop], [Ixo Voltage Drop] and [Flux Current Ref]. "Static Tune" (1) = A temporary command that initiates a non-rotational motor stator resistance test for the best possible automatic setting of [IR Voltage Drop] in all valid modes and a non-rotational motor leakage inductance test for the best possible automatic setting of [Ixo Voltage Drop] in "Flux Vector" mode. A start command is required following initiation of this setting. The parameter returns to "Ready" (0) following the test, at which time another start transition is required to operate the drive in normal mode. Used when motor cannot be rotated. "Rotate Tune" (2) = A temporary command that initiates a "Static Tune" followed by a rotational test for the best possible automatic setting of [Flux Current Ref]. In "Flux Vector" mode, with encoder feedback, a test for the best possible automatic setting of [Slip RPM @ FLA] is also run. A start command is required following initiation of this setting. The parameter returns to "Ready" (0) following the test, at which time another start transition is required to operate the drive in normal mode. Important: Used when motor is uncoupled from the load. Results may not be valid if a load is coupled to the motor during this procedure.		
			 ATTENTION: Rotation of the motor in an undesired direction can occur during this procedure. To guard against possible injury and/or equipment damage, it is recommended that the motor be disconnected from the load before proceeding.		
			"Calculate" (3) = This setting uses motor nameplate data to automatically set [IR Voltage Drop], [Ixo Voltage Drop], [Flux Current Ref] and [Slip RPM @ FLA].		
	Speed Feedback	412	Vector [Motor Fdbk Type] Selects the encoder type; single channel or quadrature. Options 1 & 3 detect a loss of encoder signal (when using differential inputs).	Default: 0 "Quadrature" Options: 0 "Quadrature" 1 "Quad Check" 2 "Single Chan" 3 "Single Check"	
		413	Vector [Encoder PPR] Contains the encoder pulses per revolution	Default: 1024 PPR Min/Max: 2/20000 PPR Units: 1 PPR	

File	Group	No.	Parameter Name & Description	Values	Related
SPEED COMMAND	Spd Mode & Limits	079	Vector [Speed Units] Selects the units to be used for all speed related parameters. Options 0 & 1 indicate status only. Options 3 & 4 will convert/configure the drive. "Convert Hz" - converts all speed based parameters to Hz, and changes the value proportionately (i.e. 1800 RPM = 60 Hz). "Convert RPM" - converts all speed based parameters to RPM, and changes the value proportionately.	Default: 0 "Hz" Options: 0 "Hz" 1 "RPM" 2 "Convert Hz" 3 "Convert RPM"	
		080	Standard [Speed Mode] Sets the method of speed regulation.	Default: 0 "Open Loop" Options: 0 "Open Loop" 1 "Slip Comp" 2 "Process PI"	
			Vector [Feedback Select] Selects the source for motor speed feedback. "Open Loop" - no encoder is present, and slip compensation is not needed. "Slip Comp" - tight speed control is needed, and encoder is not present. "Encoder" - an encoder is present. "Simulator" - Simulates a motor for testing drive operation & interface checkout.	Default: 0 "Open Loop" Options: 0 "Open Loop" 1 "Slip Comp" 2 "Reserved" 3 "Encoder" 4 "Reserved" 5 "Simulator"	
		081	[Minimum Speed] Sets the low limit for speed reference after scaling is applied. Refer to parameter 083 [Overspeed Limit].	Default: 0.0 Min/Max: 0.0/[Maximum Speed] Units: 0.1 Hz 0.1 RPM Vector	079 083 092 095
		082	[Maximum Speed] Sets the high limit for speed reference after scaling is applied. Refer to parameter 083 [Overspeed Limit].	Default: 50.0 or 60.0 Hz (volt class) [Motor NP RPM] Min/Max: 5.0/400.0 Hz 5.0/400.0 Hz Vector 0.0/24000.0 RPM Vector Units: 0.1 Hz 0.1 RPM Vector	055 079 083 091 094 202
Speed Reference	Speed Reference	090	[Speed Ref A Sel] Selects the source of the speed reference to the drive unless [Speed Ref B Sel] or [Preset Speed 1-7] is selected. (1) See User Manual for DPI port locations.	Default: 2 "Analog In 2" Options: 1 "Analog In 1" 2 "Analog In 2" 3-6 "Reserved" 7 "Pulse In" 8 "Encoder" 9 "MOP Level" 10 "Reserved" 11-17 "Preset Spd1-7" 18-22 "DPI Port 1-5"(1)	002 091 thru 093 101 thru 107 117 thru 120 192

File	Group	No.	Parameter Name & Description	Values	Related
SPEED COMMAND	Speed Reference	091	[Speed Ref A Hi] Scales the upper value of the [Speed Ref A Sel] selection when the source is an analog input.	Default: [Maximum Speed] Min/Max: $-/+$ [Maximum Speed] Units: 0.1 Hz 0.01 RPM Vector	079 082
		092	[Speed Ref A Lo] Scales the lower value of the [Speed Ref A Sel] selection when the source is an analog input.	Default: 0.0 Min/Max: $-/+$ [Maximum Speed] Units: 0.1 Hz 0.01 RPM Vector	079 081
	Discrete Speeds	101	[Preset Speed 1]	Default: 5.0 Hz/150 RPM Vector 10.0 Hz/300 RPM Vector 20.0 Hz/600 RPM Vector 30.0 Hz/900 RPM Vector 40.0 Hz/1200 RPM Vector 50.0 Hz/1500 RPM Vector 60.0 Hz/1800 RPM Vector Min/Max: $-/+$ [Maximum Speed] Units: 0.1 Hz 1 RPM Vector	079 090 093
		102	[Preset Speed 2]		
		103	[Preset Speed 3]		
		104	[Preset Speed 4]		
		105	[Preset Speed 5]		
		106	[Preset Speed 6]		
		107	[Preset Speed 7] Provides an internal fixed speed command value. In bipolar mode direction is commanded by the sign of the reference.		
	DYNAMIC CONTROL	Ramp Rates	140	[Accel Time 1]	Default: 10.0 Secs 10.0 Secs Min/Max: 0.1/3600.0 Secs Units: 0.1 Secs
141			[Accel Time 2] Sets the rate of accel for all speed increases. $\frac{\text{Max Speed}}{\text{Accel Time}} = \text{Accel Rate}$		
Ramp Rates		142	[Decel Time 1]	Default: 10.0 Secs 10.0 Secs Min/Max: 0.1/3600.0 Secs Units: 0.1 Secs	140 141 146 361 thru 366
		143	[Decel Time 2] Sets the rate of decel for all speed decreases. $\frac{\text{Max Speed}}{\text{Decel Time}} = \text{Decel Rate}$		
		146	[S Curve %] Sets the percentage of accel or decel time that is applied to the ramp as S Curve. Time is added, 1/2 at the beginning and 1/2 at the end of the ramp.		
Load Limits		148	[Current Lmt Val] Defines the current limit value when [Current Lmt Sel] = "Cur Lim Val."	Default: [Rated Amps] \times 1.5 (Equation yields approximate default value.) Min/Max: Based on Drive Rating Units: 0.1 Amps	147 149
		150	[Drive OL Mode] Selects the drive's response to increasing drive temperature.	Default: 3 "Both-PWM 1st" Options: 0 "Disabled" 1 "Reduce CLim" 2 "Reduce PWM" 3 "Both-PWM 1st"	219

File	Group	No.	Parameter Name & Description	Values	Related
DYNAMIC CONTROL	Load Limits	151	[PWM Frequency] Sets the carrier frequency for the PWM output. Drive derating may occur at higher carrier frequencies. For derating information, refer to the <i>PowerFlex Reference Manual</i> .	Default: 4 kHz Min/Max: 2/10 kHz Units: 1 kHz	
		155 156	Standard [Stop Mode A] Standard [Stop Mode B] Active stop mode. [Stop Mode A] is active unless [Stop Mode B] is selected by inputs. (1) When using options 1 or 2, refer to the Attention statements at [DC Brake Level] in the User Manual.	Default: 1 "Ramp" Default: 0 "Coast" Options: 0 "Coast" 1 "Ramp" ⁽¹⁾ 2 "Ramp to Hold" ⁽¹⁾ 3 "DC Brake"	157 158 159
	Restart Modes	169	[Flying Start En] Enables/disables the function which reconnects to a spinning motor at actual RPM when a start command is issued. Not required in Flux Vector mode when using an encoder.	Default: 0 "Disabled" Options: 0 "Disabled" 1 "Enabled"	170
		Drive Memory	196	[Param Access Lvl] Selects the parameter display level. Basic = Reduced param. set Advanced = Full param. set	Default: 0 "Basic" Options: 0 "Basic" 1 "Advanced" 2 "Reserved" Vector
201	[Language] Selects the display language when using an LCD HIM. This parameter is not functional with an LED HIM.		Default: 0 "Not Selected" Options: 0 "Not Selected" 1 "English" 2 "Francais" 3 "Español" 4 "Italiano" 5 "Deutsch" 6 "Reserved" 7 "Português" 8-9 "Reserved" 10 "Nederlands"		
UTILITY	Faults	240	[Fault Clear] Resets a fault and clears the fault queue.	Default: 0 "Ready" Options: 0 "Ready" 1 "Clear Faults" 2 "Clr Flt Que"	

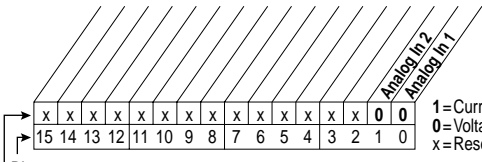

File	Group	No.	Parameter Name & Description	Values	Related
INPUTS & OUTPUTS	Analog Inputs	320	<p>[Anlg In Config]</p> <p> Selects the mode for the analog inputs.</p> <div style="text-align: center;">  <p>Bit #</p> </div> <p>Factory Default Bit Values</p>		322 325 323 326
		322	[Analog In 1 Hi]	Default: 10.000 Volt	091
		325	[Analog In 2 Hi]	Default: 10.000 Volt	092
			<p>Sets the highest input value to the analog input x scaling block.</p> <p>[Anlg In Config], parameter 320 defines if this input will be $-/+10V$ or 4-20 mA.</p>	<p>Min/Max: 4.000/20.000mA $-/+10.000V$ 0.000/10.000V</p> <p>Units: 0.001 mA 0.001 Volt</p>	
		323	[Analog In 1 Lo]	Default: 0.000 Volt	091
		326	[Analog In 2 Lo]	Default: 0.000 Volt	092
			<p>Sets the lowest input value to the analog input x scaling block.</p> <p>[Anlg In Config], parameter 320 defines if this input will be $-/+10V$ or 4-20 mA.</p>	<p>Min/Max: 4.000/20.000mA $-/+10.000V$ 0.000/10.000V</p> <p>Units: 0.001 mA 0.001 Volt</p>	

File	Group	No.	Parameter Name & Description	Values	Related																																																																								
		361	[Digital In1 Sel]	Default: 4 "Stop – CF"																																																																									
		362	[Digital In2 Sel]	Default: 5 "Start"																																																																									
		363	[Digital In3 Sel]	Default: 18 "Auto/ Manual"																																																																									
		364	[Digital In4 Sel]	Default: 15 "Speed Sel 1"																																																																									
		365	[Digital In5 Sel]	Default: 16 "Speed Sel 2"																																																																									
		366	[Digital In6 Sel] ⁽¹¹⁾	Default: 17 "Speed Sel 3"																																																																									
			<p> Selects the function for the digital inputs.</p> <p>(1) Speed Select Inputs.</p> <table border="1" data-bbox="284 443 569 630"> <thead> <tr> <th>3</th> <th>2</th> <th>1</th> <th>Auto Reference Source</th> </tr> </thead> <tbody> <tr><td>0</td><td>0</td><td>0</td><td>Reference A</td></tr> <tr><td>0</td><td>0</td><td>1</td><td>Reference B</td></tr> <tr><td>0</td><td>1</td><td>0</td><td>Preset Speed 2</td></tr> <tr><td>0</td><td>1</td><td>1</td><td>Preset Speed 3</td></tr> <tr><td>1</td><td>0</td><td>0</td><td>Preset Speed 4</td></tr> <tr><td>1</td><td>0</td><td>1</td><td>Preset Speed 5</td></tr> <tr><td>1</td><td>1</td><td>0</td><td>Preset Speed 6</td></tr> <tr><td>1</td><td>1</td><td>1</td><td>Preset Speed 7</td></tr> </tbody> </table> <p>To access Preset Speed 1, set [Speed Ref x Sel] to "Preset Speed 1".</p> <p>Type 2 Alarms - Some digital input programming may cause conflicts that will result in a Type 2 alarm. Example: [Digital In1 Sel] set to "5, Start" in 3-wire control and [Digital In2 Sel] set to 7 "Run" in 2-wire.</p> <p>Refer to User Manual for information on resolving this type of conflict.</p> <p>(2) Vector Control Option Only.</p> <p>(3)</p> <table border="1" data-bbox="284 922 569 1109"> <thead> <tr> <th>3</th> <th>2</th> <th>1</th> <th>Spd/Trq Mode</th> </tr> </thead> <tbody> <tr><td>0</td><td>0</td><td>0</td><td>Zero Torque</td></tr> <tr><td>0</td><td>0</td><td>1</td><td>Spd Reg</td></tr> <tr><td>0</td><td>1</td><td>0</td><td>Torque Reg</td></tr> <tr><td>0</td><td>1</td><td>1</td><td>Min Spd/Trq</td></tr> <tr><td>1</td><td>0</td><td>0</td><td>Max Spd/Trq</td></tr> <tr><td>1</td><td>0</td><td>1</td><td>Sum Spd/Trq</td></tr> <tr><td>1</td><td>1</td><td>0</td><td>Absolute</td></tr> <tr><td>1</td><td>1</td><td>1</td><td>Zero Trq</td></tr> </tbody> </table>	3	2	1	Auto Reference Source	0	0	0	Reference A	0	0	1	Reference B	0	1	0	Preset Speed 2	0	1	1	Preset Speed 3	1	0	0	Preset Speed 4	1	0	1	Preset Speed 5	1	1	0	Preset Speed 6	1	1	1	Preset Speed 7	3	2	1	Spd/Trq Mode	0	0	0	Zero Torque	0	0	1	Spd Reg	0	1	0	Torque Reg	0	1	1	Min Spd/Trq	1	0	0	Max Spd/Trq	1	0	1	Sum Spd/Trq	1	1	0	Absolute	1	1	1	Zero Trq	<p>Options:</p> <p>0 "Not Used"</p> <p>1 "Enable"⁽⁸⁾⁽¹⁰⁾</p> <p>2 "Clear Faults"(CF)⁽⁴⁾</p> <p>3 "Aux Fault"</p> <p>4 "Stop – CF"⁽⁵⁾⁽¹⁰⁾</p> <p>5 "Start"⁽⁵⁾⁽⁹⁾</p> <p>6 "Fwd/ Reverse"⁽⁵⁾</p> <p>7 "Run"⁽⁶⁾⁽¹⁰⁾</p> <p>8 "Run Forward"⁽⁶⁾</p> <p>9 "Run Reverse"⁽⁶⁾</p> <p>10 "Jog"⁽⁵⁾ "Jog1"⁽²⁾⁽⁵⁾</p> <p>11 "Jog Forward"</p> <p>12 "Jog Reverse"</p> <p>13 "Stop Mode B"</p> <p>14 "Bus Reg Md B"</p> <p>15-17 "Speed Sel 1-3"⁽¹⁾</p> <p>18 "Auto/ Manual"⁽⁷⁾</p> <p>19 "Local"</p> <p>20 "Acc2 & Dec2"</p> <p>21 "Accel 2"</p> <p>22 "Decel 2"</p> <p>23 "MOP Inc"</p> <p>24 "MOP Dec"</p> <p>25 "Excl Link"</p> <p>26 "PI Enable"</p> <p>27 "PI Hold"</p> <p>28 "PI Reset"</p> <p>29 "Pwr Loss Lvl"</p> <p>30 "Precharge En"</p> <p>31-33 "Spd/Trq Sel1-3"^(2,3)</p> <p>34 "Jog 2"⁽²⁾</p>	<p>100</p> <p>156</p> <p>162</p> <p>096</p> <p>140</p> <p>194</p> <p>380</p> <p>384</p> <p>388</p> <p>124</p>
3	2	1	Auto Reference Source																																																																										
0	0	0	Reference A																																																																										
0	0	1	Reference B																																																																										
0	1	0	Preset Speed 2																																																																										
0	1	1	Preset Speed 3																																																																										
1	0	0	Preset Speed 4																																																																										
1	0	1	Preset Speed 5																																																																										
1	1	0	Preset Speed 6																																																																										
1	1	1	Preset Speed 7																																																																										
3	2	1	Spd/Trq Mode																																																																										
0	0	0	Zero Torque																																																																										
0	0	1	Spd Reg																																																																										
0	1	0	Torque Reg																																																																										
0	1	1	Min Spd/Trq																																																																										
1	0	0	Max Spd/Trq																																																																										
1	0	1	Sum Spd/Trq																																																																										
1	1	0	Absolute																																																																										
1	1	1	Zero Trq																																																																										
			<p>(4) When [Digital Inx Sel] is set to option 2 "Clear Faults" the Stop button cannot be used to clear a fault condition.</p> <p>(5) Typical 3-Wire Inputs - Requires that only 3-wire functions are chosen. Including 2-wire selections will cause a type 2 alarm.</p> <p>(6) Typical 2-Wire Inputs - Requires that only 2-wire functions are chosen. Including 3-wire selections will cause a type 2 alarm.</p> <p>(7) Auto/Manual - Refer to "Reference Control" in the User Manual for details.</p> <p>(8) Opening an "Enable" input will cause the motor to coast-to-stop, ignoring any programmed Stop modes.</p> <p>(9) A "Dig In ConflictB" alarm will occur if a "Start" input is programmed without a "Stop" input.</p> <p>(10) Refer to the Sleep-Wake Mode Attention statement in the User Manual.</p> <p>(11) A dedicated hardware enable input is available via a jumper selection. Refer to page 13 for further information.</p>																																																																										

Troubleshooting – Abbreviated Fault & Alarm Listing

For a complete listing of Faults and Alarms, refer to the PowerFlex 700 User Manual.



Fault	No.	Type ⁽¹⁾	Description	Action
Auxiliary Input	2	①	Auxiliary input interlock is open.	Check remote wiring.
Motor Overload	7	① ③	Internal electronic overload trip. Enable/Disable with [Fault Config 1].	An excessive motor load exists. Reduce load so drive output current does not exceed the current set by [Motor NP FLA].
OverSpeed Limit	25	①	Functions such as Slip Compensation or Bus Regulation have attempted to add an output frequency adjustment greater than that programmed in [Overspeed Limit].	Remove excessive load or overhauling conditions or increase [Overspeed Limit].
SW OverCurrent	36	①	Drive output current has exceeded the 1ms current rating. This rating is greater than the 3 second current rating and less than the hardware overcurrent fault level. It is typically 200-250% of the drive continuous rating	Check for excess load, improper DC boost setting. DC brake volts set too high.
DB Resistance	69		Resistance of the internal DB resistor is out of range.	Replace resistor.
IR Volts Range	77		"Calculate" is the autotune default and the value determined by the autotune procedure for IR Drop Volts is not in the range of acceptable values.	Re-enter motor nameplate data.
FluxAmpsRef Rang	78		The value for flux amps determined by the Autotune procedure exceeds the programmed [Motor NP FLA].	1. Reprogram [Motor NP FLA] with the correct motor nameplate value. 2. Repeat Autotune.

⁽¹⁾ See the User Manual for a description of fault types.

Alarm	No.	Type(1)	Description																																																																																																				
Dig In ConflictA	17	②	Digital input functions are in conflict. Combinations marked with a "⚡" will cause an alarm. * Jog 1 and Jog 2 with Vector Control Option																																																																																																				
			<table border="1"> <thead> <tr> <th></th> <th>Acc2/Dec2</th> <th>Accel 2</th> <th>Decel 2</th> <th>Jog</th> <th>Jog Fwd</th> <th>Jog Rev</th> <th>Fwd/Rev</th> </tr> </thead> <tbody> <tr> <td>Acc2 / Dec2</td> <td></td> <td>⚡</td> <td>⚡</td> <td></td> <td></td> <td></td> <td></td> </tr> <tr> <td>Accel 2</td> <td>⚡</td> <td></td> <td></td> <td></td> <td></td> <td></td> <td></td> </tr> <tr> <td>Decel 2</td> <td>⚡</td> <td></td> <td></td> <td></td> <td></td> <td></td> <td></td> </tr> <tr> <td>Jog*</td> <td></td> <td></td> <td></td> <td></td> <td>⚡</td> <td>⚡</td> <td></td> </tr> <tr> <td>Jog Fwd</td> <td></td> <td></td> <td></td> <td>⚡</td> <td></td> <td></td> <td>⚡</td> </tr> <tr> <td>Jog Rev</td> <td></td> <td></td> <td></td> <td>⚡</td> <td></td> <td></td> <td>⚡</td> </tr> <tr> <td>Fwd / Rev</td> <td></td> <td></td> <td></td> <td></td> <td>⚡</td> <td>⚡</td> <td></td> </tr> </tbody> </table>		Acc2/Dec2	Accel 2	Decel 2	Jog	Jog Fwd	Jog Rev	Fwd/Rev	Acc2 / Dec2		⚡	⚡					Accel 2	⚡							Decel 2	⚡							Jog*					⚡	⚡		Jog Fwd				⚡			⚡	Jog Rev				⚡			⚡	Fwd / Rev					⚡	⚡																																					
				Acc2/Dec2	Accel 2	Decel 2	Jog	Jog Fwd	Jog Rev	Fwd/Rev																																																																																													
			Acc2 / Dec2		⚡	⚡																																																																																																	
			Accel 2	⚡																																																																																																			
			Decel 2	⚡																																																																																																			
			Jog*					⚡	⚡																																																																																														
			Jog Fwd				⚡			⚡																																																																																													
Jog Rev				⚡			⚡																																																																																																
Fwd / Rev					⚡	⚡																																																																																																	
Dig In ConflictB	18	②	A digital Start input has been configured without a Stop input or other functions are in conflict. Combinations that conflict are marked with a "⚡" and will cause an alarm. * Jog 1 and Jog 2 with Vector Control Option																																																																																																				
			<table border="1"> <thead> <tr> <th></th> <th>Start</th> <th>Stop-CF</th> <th>Run</th> <th>Run Fwd</th> <th>Run Rev</th> <th>Jog</th> <th>JogFwd</th> <th>Jog Rev</th> <th>Fwd/Rev</th> </tr> </thead> <tbody> <tr> <td>Start</td> <td></td> <td></td> <td>⚡</td> <td>⚡</td> <td>⚡</td> <td></td> <td>⚡</td> <td>⚡</td> <td></td> </tr> <tr> <td>Stop-CF</td> <td></td> <td></td> <td></td> <td></td> <td></td> <td></td> <td></td> <td></td> <td></td> </tr> <tr> <td>Run</td> <td>⚡</td> <td></td> <td></td> <td>⚡</td> <td>⚡</td> <td></td> <td>⚡</td> <td>⚡</td> <td></td> </tr> <tr> <td>Run Fwd</td> <td>⚡</td> <td></td> <td>⚡</td> <td></td> <td></td> <td>⚡</td> <td></td> <td></td> <td>⚡</td> </tr> <tr> <td>Run Rev</td> <td>⚡</td> <td></td> <td>⚡</td> <td></td> <td></td> <td>⚡</td> <td></td> <td></td> <td>⚡</td> </tr> <tr> <td>Jog*</td> <td></td> <td></td> <td></td> <td>⚡</td> <td>⚡</td> <td></td> <td></td> <td></td> <td></td> </tr> <tr> <td>Jog Fwd</td> <td>⚡</td> <td></td> <td>⚡</td> <td></td> <td></td> <td></td> <td></td> <td></td> <td></td> </tr> <tr> <td>Jog Rev</td> <td>⚡</td> <td></td> <td>⚡</td> <td></td> <td></td> <td></td> <td></td> <td></td> <td></td> </tr> <tr> <td>Fwd / Rev</td> <td></td> <td></td> <td></td> <td>⚡</td> <td>⚡</td> <td></td> <td></td> <td></td> <td></td> </tr> </tbody> </table>		Start	Stop-CF	Run	Run Fwd	Run Rev	Jog	JogFwd	Jog Rev	Fwd/Rev	Start			⚡	⚡	⚡		⚡	⚡		Stop-CF										Run	⚡			⚡	⚡		⚡	⚡		Run Fwd	⚡		⚡			⚡			⚡	Run Rev	⚡		⚡			⚡			⚡	Jog*				⚡	⚡					Jog Fwd	⚡		⚡							Jog Rev	⚡		⚡							Fwd / Rev				⚡	⚡				
				Start	Stop-CF	Run	Run Fwd	Run Rev	Jog	JogFwd	Jog Rev	Fwd/Rev																																																																																											
			Start			⚡	⚡	⚡		⚡	⚡																																																																																												
			Stop-CF																																																																																																				
			Run	⚡			⚡	⚡		⚡	⚡																																																																																												
			Run Fwd	⚡		⚡			⚡			⚡																																																																																											
			Run Rev	⚡		⚡			⚡			⚡																																																																																											
			Jog*				⚡	⚡																																																																																															
			Jog Fwd	⚡		⚡																																																																																																	
Jog Rev	⚡		⚡																																																																																																				
Fwd / Rev				⚡	⚡																																																																																																		
Dig In ConflictC	19	②	More than one physical input has been configured to the same input function. Multiple configurations are not allowed for the following input functions.																																																																																																				
			Forward/Reverse	Run Reverse	Bus Regulation Mode B																																																																																																		
			Speed Select 1	Jog Forward	Acc2 / Dec2																																																																																																		
			Speed Select 2	Jog Reverse	Accel 2																																																																																																		
			Speed Select 3	Run	Decel 2																																																																																																		
			Run Forward	Stop Mode B																																																																																																			

(1) See User Manual for a description of alarm types.

Manually Clearing Faults

Step	Key(s)
1. Press Esc to acknowledge the fault. The fault information will be removed so that you can use the HIM.	
2. Address the condition that caused the fault. The cause must be corrected before the fault can be cleared.	
3. After corrective action has been taken, clear the fault by: <ul style="list-style-type: none"> Pressing Stop Cycling drive power Set parameter 240 [Fault Clear] to "1." "Clear Faults" on the HIM Diagnostic menu. 	

www.rockwellautomation.com

Corporate Headquarters

Rockwell Automation, 777 East Wisconsin Avenue, Suite 1400, Milwaukee, WI, 53202-5302 USA, Tel: (1) 414.212.5200, Fax: (1) 414.212.5201

Headquarters for Allen-Bradley Products, Rockwell Software Products and Global Manufacturing Solutions

Americas: Rockwell Automation, 1201 South Second Street, Milwaukee, WI 53204-2496 USA, Tel: (1) 414.382.2000, Fax: (1) 414.382.4444
Europe/Middle East/Africa: Rockwell Automation SA/NV, Vorstlaan/Boulevard du Souverain 36, 1170 Brussels, Belgium, Tel: (32) 2 663 0600, Fax: (32) 2 663 0640
Asia Pacific: Rockwell Automation, 27/F Citicorp Centre, 18 Whitfield Road, Causeway Bay, Hong Kong, Tel: (852) 2887 4788, Fax: (852) 2508 1846

Headquarters for Dodge and Reliance Electric Products

Americas: Rockwell Automation, 6040 Ponders Court, Greenville, SC 29615-4617 USA, Tel: (1) 864.297.4800, Fax: (1) 864.281.2433
Europe/Middle East/Africa: Rockwell Automation, Brühlstraße 22, D-74834 Elztal-Dallau, Germany, Tel: (49) 6261 9410, Fax: (49) 6261 17741
Asia Pacific: Rockwell Automation, 55 Newton Road, #11-01/02 Revenue House, Singapore 307987, Tel: (65) 6356-9077, Fax: (65) 6356-9011

U.S. Allen-Bradley Drives Technical Support

Tel: (1) 262.512.8176, Fax: (1) 262.512.2222, Email: support@drives.ra.rockwell.com, Online: www.ab.com/support/abdrives